

File Name: 913.pdf

UNESCO Region: ASIA AND THE PACIFIC

---

**SITE NAME:** Shrines and Temples of Nikko

**DATE OF INSCRIPTION:** 4<sup>th</sup> December 1999

**STATE PARTY:** JAPAN

**CRITERIA:** C (i)(iv)(vi)

**DECISION OF THE WORLD HERITAGE COMMITTEE:**

Excerpt from the Report of the 23<sup>rd</sup> Session of the World Heritage Committee

The Committee inscribed this property on the World Heritage List on the basis of criteria (i), (iv) and (vi):

Criterion (i): The Nikko shrines and temples are a reflection of architectural and artistic genius; this aspect is reinforced by the harmonious integration of the buildings in a forest and a natural site laid out by people.

Criterion (iv): Nikko is a perfect illustration of the architectural style of the Edo period as applied to Shinto shrines and Buddhist temples. The Gongen-zukuri style of the two mausoleums, the Tōshōgū and the Taiyū-in Reibyō, reached the peak of its expression in Nikko, and was later to exert a decisive influence. The ingenuity and creativity of its architects and decorators are revealed in an outstanding and distinguished manner.

Criterion (vi): The Nikko shrines and temples, together with their environment, are an outstanding example of a traditional Japanese religious centre, associated with the Shinto perception of the relationship of man with nature, in which mountains and forests have a sacred meaning and are objects of veneration, in a religious practice that is still very much alive today.

The Committee took note of the comments of ICOMOS that the development pressure near the south-west border of the site would require the State Party to be vigilant in monitoring potential threats in the future.

**BRIEF DESCRIPTIONS**

The Nikko shrines and temples, together with their natural surroundings, have for centuries formed a sacred site known for its architectural and decorative masterpieces. They are closely associated with the history of the Tokugawa Shoguns.

---

**1.b State, Province or Region:** Tochigi Prefecture

**1.d Exact location:** 36° 44' N, 139° 36' E

# Shrines and Temples of Nikko

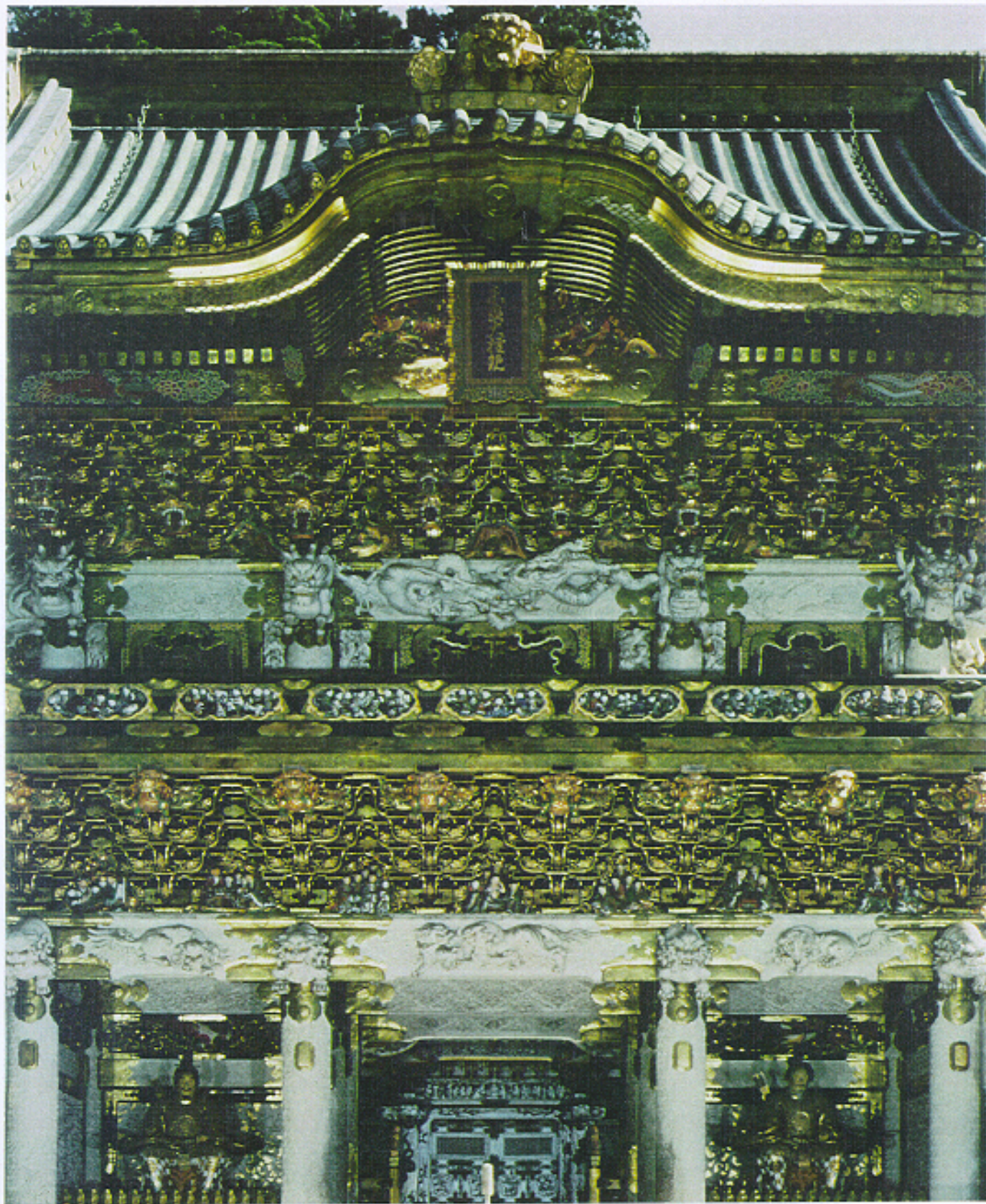

1998

Agency for Cultural Affairs, Environment Agency  
Government of Japan

WORLD HERITAGE LIST NOMINATION

[File No.1]

## CONTENTS

Main Text

Appendices

1. Maps indicating the location of the nominated property
  - a. The location in Japan
  - b. The location in the Kanto Area
  - c. The location in Nikko City
2. Map indicating the nominated property and the surrounding natural and built environment
3. Map indicating the extent of the nominated property and the buffer zone
  - a. The extent of the nominated property and the buffer zone with indication of the zones of legal protection
  - b. The distribution of buildings designated as national treasures or important cultural properties
4. Inventory of the cultural assets; copies of the official designation notices
  - a. inventory of the buildings (national treasures and important cultural properties) included in the nominated property
  - b. Copies of the official notices
5. Drawings of the major buildings (national treasures and important cultural properties)
6. Chronological table of Nikko's history in relation to the nominated property
7. Plan indicating locations of fire prevention systems
8. Map indicating the zones of legal protection
9. Summary of laws and regulations which control the nominated property and the buffer zone
10. Map of the area relevant to agreed plans related to the nominated property
11. Chronological table of conservation work
12. Plan indicating locations of the buildings for which conservation work has been completed
13. Plan indicating locations of support facilities and facilities for visitors

## Additional Reference Materials

### 1. Laws and regulations

The Law for the Protection of Cultural Properties

The Natural Parks Law (Excerpt)

The Nikko Municipal Ordinance Concerning Townscape (Excerpt)

The Preservation Management Plan for the Nikko Sannai Historic Site (Excerpt)

The Management Plan for Nikko National Park Nikko District (Summary)

MAIN TEXT

WORLD HERITAGE LIST NOMINATION

JAPAN

Shrines and Temples of Nikko

1998

Agency for Cultural Affairs, Environment Agency  
Government of Japan

WORLD HERITAGE LIST NOMINATION

Name of Property

**Shrines and Temples of Nikko**

State Party

**Japan**

Prepared by

**Agency for Cultural Affairs, Environment Agency  
Government of Japan**

Date

**June 1998**

## CONTENTS

### Main Text [File No.1]

#### 1 . Identification of the Property

- a. Country 1
- b. State, Province or Region 1
- c. Name of property 1
- d. Location 1
- e. Boundary of area proposed for inscription and of buffer zone 1
- f. Area of property proposed for inscription and of buffer zone 2

#### 2 . Justification for Inscription

- a. Statement of significance 3
- b. Comparative analysis 6
- c. Authenticity 6
- d. Criteria under which inscription is proposed 9

#### 3 . Description

- a. Description of property 11
- b. History 23
- c. Form and date of most recent records of property 28
- d. Present state of conservation 33
- e. Policies and programs related to the presentation and promotion of property 36

#### 4 . Management

- a. Ownership 39
- b. Legal status 39
- c. Protective measures and means of implementing them 41
- d. Agencies with management authority 43
- e. Level at which management is exercised and name and address of responsible person for contact purposes 43
- f. Agreed plans related to property 43
- g. Sources and levels of finance 44
- h. Sources of expertise and training in conservation and management techniques 44
- i. Visitor facilities and statistics 45
- j. Property management plan and statement of objectives 45
- k. Staffing levels 46

#### 5 . Factors Affecting the Property

- a. Development pressures 47
- b. Environmental pressures 47
- c. Natural disasters and preparedness 47
- d. Visitor / tourism pressures 48
- e. Number of inhabitants within property and buffer zone 48

#### 6 . Monitoring

- a. Key indicators for measuring state of conservation 49
- b. Administrative arrangements for monitoring property 50
- c. Results of previous reporting exercises 51

#### 7 . Documentation

- a. Photographs, slides and video 59
- b. Copies of property management plans and extracts of other plans relevant to property 59
- c. Bibliography 59
- d. Address where inventory, record and archives are held 59

#### 8 . Signature on behalf of the State Party



## Additional Reference Materials

### [File No.1]

1. Laws and regulations
  - a. The Law for the Protection of Cultural Properties
  - b. The Natural Parks Law (excerpt)
  - c. The Nikko City Municipal Ordinance Concerning Townscape
  - d. The Preservation Management Plan for the Nikko Sannai Historic Site (excerpt)
  - e. The Management Plan for Nikko National Park (Nikko District) (summary)

### [File No. 2]

2. Color slides

### [File No. 3 and File No. 4]

3. Videotape production

### [Other]

Nikko Tôshôgû. *Kokuhô Tôshôgû Yômeimon* [the Yômeimon of Tôshôgû: National Treasure].  
Nikko Tôshôgû, 1974.

*1. Identification of the Property*



<p><b>1. Identification of the Property</b> a. Country</p>	<p>Japan</p>
<p>b. State, Province or Region</p>	<p>Tochigi Prefecture</p>
<p>c. Name of property</p>	<p>Shrines and Temples of Nikko</p>
<p>d. Location</p>	<p>The nominated cultural property, "Shrines and Temples of Nikko", is a complex of religious facilities including the mausoleums of the Tokugawa shogunate, the feudal government of Japan founded in the 17<sup>th</sup> century. The nominated property is located in Nikko City, Tochigi Prefecture, in Japan.</p> <p>The specific location of the nominated property is shown in Appendix 1.</p> <p><b>Geographical position (location of the Nikko City office)</b>  Latitude: 36° 44' 51" N  Longitude: 139° 36' 38" E</p> <p><b>Appendix 1: maps indicating the location of the nominated property</b>  <b>1a: the location in Japan</b>  <b>1b: the location in Tochigi Prefecture in the Kanto Area</b>  <b>1c: the location in Nikko City</b></p>
<p>e. Boundary of area proposed for inscription and of buffer zone</p>	<p>Maps showing the boundaries of the area proposed for inscription and of its buffer zone are submitted herewith:</p> <p><b>Appendix 2: map indicating the nominated property and the surrounding natural and built environment</b></p> <p><b>Appendix 3: maps indicating the extent of the nominated property and the buffer zone</b>  <b>3a: the extent of the nominated property and the buffer zone with indication of the zones of legal protection</b>  <b>3b: the distribution of buildings designated as National Treasures or Important Cultural Properties</b></p>

## *2. Justification of Inscription*



## 2. Justification for Inscription

### a. Statement of significance

The nominated property dates back to the late 8<sup>th</sup> century, when the Buddhist priest Shōdō started religious activities in the Nikko Mountains, which had been worshipped as sacred mountains since ancient times. In the 1200 years since then, the area has been developed into a complex sanctum for religious followers of Shintoism, Buddhism and the deified Tokugawa family. Still now the groups of religious buildings and the awe-inspiring natural setting around them provide a stage for active religious activities which are part of the day-to-day lives of the people living in that area.

In the early 17<sup>th</sup> century, Nikko was chosen to be the site for construction of Tōshōgū, a shrine containing the mausoleum of Tokugawa Ieyasu, the founder of the Tokugawa shogunate -- the regime which was to rule the state for more than 250 years, longer than any other regime in the history of Japan. Since that time, the Nikko area assumed a significant political symbolic role in representing the sovereignty of the Tokugawa shogunate; not only local powers subordinate to the shogunate but also Ieyasu's successors, missionaries from the emperor and even delegations from the Korean Yi Dynasty visited there to pay homage to the deified Ieyasu.

The nominated property is an illustrative historical example of the Shinto-Buddhist syncretistic tradition of Japanese religion prior to the Meiji Period, when its ownership was divided among three religious organizations, i.e. Futarasan-jinja, Tōshōgū and Rinnō-ji, by the government of the time -- which adopted a policy of separation between Shintoism and Buddhism.

In addition, the nominated property is still active today as a place for religious rituals and other activities, whether Shintoist or Buddhist, contributing to keeping tradition alive both physically and spiritually in the contemporary lives of those living there.

most advanced measures for fire prevention at that time.

The other buildings constituting the nominated property, i.e. buildings of Futarasan-jinja and Rinnō-ji, were also constructions realized using the best techniques and workmanship of the time, with the support of the Tokugawa government.

Indeed, the buildings constructed in Nikko in the early 17<sup>th</sup> century were all excellent works of the painters and master carpenters in the employ of the Tokugawa shogunate. Unlike many of their contemporaries, most of whom remained anonymous, the artists or artisans engaged on the works related to the shrines and temples of Nikko were known by name. The earliest recognized geniuses in the art world of Japan, such as Kanō Tanyū, a resident shogunate artist, and Kōra Munehiro, a master builder for the shogunate, were duly credited and remembered individually for their skills fully displayed in colorful, elaborate decorations characterizing the architectural style at the beginning of the Edo Period.

Thanks to the management of the Tokugawa government, the group of buildings included in the nominated property retained their original quality through the Edo Period. They stationed a group of carpenters at Nikko as full-time staff to carry out periodical repair or restoration on the buildings. In particular, special care had been paid to Tōshōgū, for which nothing less than the highest quality of workmanship was allowed any time that repair was carried out.

Though the Tokugawa government ultimately fell as a result of revolutionary political changes, the buildings in Nikko continuously received protection from the national government. The Meiji government designated these properties as Cultural Properties under newly passed laws and introduced modern approaches to their preservation. Because of this we can still today enjoy the magnificent splendor of this fine architecture.

The Tokugawa government's attention went further than the buildings alone, extending to the forests surrounding them as well. Their foresighted

existing state which are proposed for restoration or other purposes, the permission of the national government is required based on detailed examination by the Council for the Protection of Cultural Properties, which includes many members of ICOMOS Japan.

The techniques in the repair work on the historic wooden buildings have been established through experience gained from conservation projects which have been undertaken in the modern age. In this respect, the authenticity of the nominated property as a cultural property is assured as follows:

i) Authenticity of Design

Splendid design works characteristic of the buildings included in the nominated property are seen mainly in the decorative features of the architecture, such as richly colored carving, exquisitely painted plaster and elaborate engravings. These decorative features have been maintained using the traditional techniques transmitted from the Edo Period and accordingly the designs represent authenticity of a high standard.

ii) Authenticity of Materials

The group of religious buildings in Nikko is unique in that much more attention and care have been focused upon the preservation of the coloring materials and decorative works than for any other similar architecture in Japan. As a result, the materials remain in an extremely good condition, thus guaranteeing the authenticity of the materials.

Because japan-lacquered decorative works and colorfully painted members suffer from weathering caused by exposure to humidity or rain, periodical re-finishing treatments are carried out and, whenever it is necessary to replace certain parts due to deterioration, the replacement parts are made out of traditional raw materials using strictly traditional methods.

ages.

In addition, the natural environment characterizing the area where the nominated property is located, including old-growth forests of cryptomeria trees hundreds of years old, has been adequately conserved together with its scenic beauty under the protection of National Park regulations.

In this way, the authenticity of the setting as a cultural landscape has been fairly preserved on a high level, showing excellently harmonious atmosphere between elaborately colored and carved religious architecture and the lush green forests that surround it.

d. Criteria under which inscription is proposed

The nominated property is proposed for inscription as a "*group of buildings*" and a "*site*", as set out in Article 1 of the 1972 World Heritage Convention and is also considered to be a "*cultural landscape*", as described in Paragraph 39 of the Operational Guidelines for the Implementation of the World Heritage Convention (1997).

Each building included in the nominated property represents outstanding artistic value as a masterpiece created by some of the earliest architectural geniuses in Japan. Therefore, the nominated property meets the standard of evaluation *criterion (i)*.

The two mausoleums included in the nominated property -- Tōshōgū and the Taiyū-in Reibyō -- embody complete forms of the architectural style known as *Gongen-zukuri*, the most advanced style of religious architecture in Japan at that time. Indeed, this style had great influence upon the architects of shrine buildings and mausoleums in following generations. The buildings vividly illustrate the collective ingenuity and creativity of the architects involved in the



### *3. Description*



### 3. Description

#### a. Description of property

The shrine and temple buildings included in the nominated property are proposed for inscription as a "*group of buildings*", as defined in Article 1 of the Convention Concerning the Protection of the World Cultural and Natural Heritage. At the same time, the locations of those buildings and the surrounding natural settings associated with those religious constructions are proposed for inscription as a "*site*" and should also be considered to be an "*associative cultural landscape*", as defined in Paragraph 39 (iii) of the Operational Guidelines for the Implementation of the World Heritage Convention.

The nominated property consists of a group of 103 buildings, under the management of two Shinto organizations and one Buddhist organization, and the natural setting around them. Each of these is of outstanding significance in terms of Japanese history.

Descriptions of the major buildings included in the nominated property and the cultural landscapes produced by the combination of the architecture and the surrounding environment follow below:

#### **Group of Buildings**

##### **A. Futarasan-jinja (Futarasan Shinto Shrine)**

Futarasan-jinja has long been revered as the primary shrine, enshrining the three deities, Ōnamuchi no Mikoto, Tagorihime no Mikoto and Ajisukitakahikone no Mikoto, closely associated with the sacred mountains of Nikko.

Futarasan-jinja traces its origins back to its prototype called Shingū, which, the shrine legend holds, existed in 850 near the place where the Shōrō (bell house) of Tōshōgū is now located. This prototype shrine, together with Takino-o-jinja and Hongū-jinja, were known and revered as the trinity of Nikko

decorative engraving for ornamental effect -- the original style which the Haiden has retained since its foundation.

**The Shinkyô (A6)**, or the sacred bridge, is known to have existed already on the present site spanning the Daiya River in the Muromachi Period (according to remaining archival records) though the exact date of its construction is not clear. It was in 1636 that this bridge took on its present style as a vermilion-lacquered wooden bridge on massive stone piers piled down close to the riverbanks. Though demolished in a flash flood in 1902, it was reconstructed and restored to its 17<sup>th</sup>-century condition in 1904.

**The Betsugû Takino-o-jinja Honden (A7)**, as the shrine legend tells us, was founded back in 825. It was relocated to the present location in 1646 and was later remodeled in 1713. It was destroyed in 1941 by a falling tree broken by a storm, but it was soon reconstructed, reusing the surviving original structural members as much as possible. This building has a door at the back overlooking Mt. Nyohôsan -- a unique feature provided for worship of this sacred mountain.

**The Betsugû Hongû-jinja Honden (A12)** is said to have originally been built in 808 and relocated to the present location in 850. Though this hall was burned to ashes twice in the past, it was immediately reconstructed each time to the original style. The Betsugû Hongû-jinja Honden that we see today is a 1685 reconstruction.

**The Shin-yosha (A16)** was built in 1617 originally as a temporary worship hall of Tôshôgû. It was later relocated twice (in 1638 and in 1641) before it was set in the present location. Although it is a simply-designed bare wood construction that is small in scale (with a 3-bay front and 2-bay sides), its significance is as great as any other building included in the nominated property; the Shin-yosha is the oldest remaining source of direct information about the architectural style used for Tôshôgû at its earliest stage of construction.

Honden stands were replaced in 1690.

This building consisting of three chambers is a perfect realization of the *Gongen-zukuri*, a Japanese architectural style in which the Honden (main hall) and the Haiden (worship hall) are linked in an H shape by a central stone-floored chamber called the *Ishinoma*. As such, it has shed great influence upon the architectural style of mausoleums and other shrine buildings in following generations, providing the role model to follow as a source of inspiration. Most experienced and skilled craftsmen at that time were involved throughout the process of construction, including the design of the decorative carving and coloring.

**The Shōmen Karamon and the Haimen Karamon (B2)**, constructed in 1636, have not changed from the original, except for the roofing materials which were replaced for maintenance reasons. In particular, the Shōmen Karamon shows skillful workmanship in its structure and decoration; the four eaves projections were designed into cusped gables after a Chinese fashion and the engraved works designed in woven patterns, the inlaid works and the copper sculptures on the roof are unquestionably masterpieces of decoration.

**The Tōzai Sukibê (B3)**, founded in 1636, has not changed from its original condition except that the materials for the foundation and the roofing were replaced for maintenance reasons. This wall, stretching out from both sides of the Karamon for 87 bays (approximately 160 m), encloses the Honden, *Ishinoma* and Haiden. The openwork carving in floral patterns on the latticed-windowed wall and the openwork sculpture in the shapes of birds and flowers on the transom are distinctively elegant features of this construction, different in design from the other structures.

**The Yōmeimon (B4)**, probably the most famous work of architecture in Nikko, was erected in 1636 and has been maintained through repeated roofing repair and painting repair to keep it in a condition equal to that at the time of original construction, including its decorative sculpture and other decorative

the only unpainted bare wood construction among all of the buildings of Tōshōgū and it is the largest extant horse stable constructed at that time.

**The Gojūnotō (B19)** is an 1818 reconstruction of the original five-storied pagoda, which was erected in 1650, but which was lost in a fire in 1815. In order to make the tower stable enough to resist wind and earthquake forces, the center pillar is suspended on the fourth story and held 10 cm above the ground -- not resting on a foundation stone -- thereby functioning as a dynamic counter-weight which maintains the center of gravity.

**The Ishidorii (B20)** has remained in its original form since its construction in 1618. The torii gate, which is 9.2 m tall and 13.2 m wide, is made out of 15 blocks of stone, instead of wood, which is the material usually used for torii. The Ishidorii has a unique structure well designed to resist earthquakes; the primary top rail and the secondary top rail, called *Kasagi* and *Shimaki*, are hollowed in order to minimize the weight and a pair of grafted stone columns are set firmly to support them.

**The Sakashitamon (B21)** was erected in 1636 as the entrance gate to the Okusha. It has remained in its original form since its construction except for minor changes resulting from the process of repairing roofing, painting and metal fittings. Its decoration characterized by the use of cloisonné-enameled fittings projects a distinctive impression of brightness.

**The Okusha Hōtō (B22)** was originally a wooden building when first constructed in 1622, but was remodeled into a stone structure in 1641. The bronze pagoda which we see now is a 1683 reconstruction, built after an earthquake destroyed the stone building. In order to keep dry the remains of Tokugawa Ieyasu, enshrined underground beneath the pagoda, the stone-bedded floor is sloped to drain outward and the joints of the stone blocks constituting the stepped foundation are sealed with lead to block the penetration of rainwater.

**The Otabisho Honden (B34)** is a 1685 reconstruction; the original

show excellent design skill enhanced by innovative ideas applied in various ways.

In 1871, when the Meiji government issued the Shintoism and Buddhism Separation Decree, Rinnô-ji was separated from Futarasan-jinja and Tôshôgû. In the process, the Hondô (Sambutsudô) and the Sôrintô were relocated to their present locations.

Since their foundation, the temple buildings have been maintained in their original style through adequate repair work, which has been conducted on the basis of traditional techniques in reference to the site plan and the building drawings drawn in 1687 and the Kekkôsho, a 1753 document prescribing specifications on design, color and other aspects of the architecture.

The Taiyû-in Reibyô Honden, the Taiyû-in Reibyô Ainoma and the Taiyû-in Reibyô Haiden are designated collectively as a National Treasure under the Law for the Protection of Cultural Properties, while 37 other buildings are designated by the national government as Important Cultural Properties under the same law.

**The Taiyû-in Reibyô Honden, Ainoma and Haiden (C17)** was founded in 1653. It has been maintained to this day without alteration except that traces of minor changes are to be noticed in the painting finish ascribed to repair work carried out in the Edo Period.

The composition of three chambers in this precinct represents the *Gongen-zukuri* style, which is basically the same style in which the buildings of Tôshôgû are arranged. The arrangement of the former is different from the latter in that the Taiyû-in Reibyô Ainoma, the counterpart to the Ishinoma, is on the same level as the Taiyû-in Reibyô Haiden and also in that the Taiyû-in Reibyô Honden has a double-layered roof.

It is known that the policy of construction from the earliest stage was to achieve the highest quality decorative workmanship in the engraving,

offering a graceful presentation of the typical architectural style of the middle Edo Period.

The Taiyû-in Reibyô Karamon, Yashamon and Kôkamon, whose descriptions are given below separately, were erected in 1653 as a group of gates leading into the Taiyû-in Reibyô. They have been maintained to this day without any alteration in their form.

**The Taiyû-in Reibyô Karamon (C18)** has a Chinese style gable on the front entry side. It is an excellent work of carpentry in terms of both structure and decorative design, which are expressed in minutely engraved woven patterns and metal openwork.

**The Taiyû-in Reibyô Yashamon (C23)** is a gate with four Chinese style gables, featuring eight supporting columns. Excellent workmanship is fully exercised in the structure and decorative design of the gate, especially in the peony carvings, which are applied consistently as the main motif for decorating this particular gate. Another example of excellent decoration is the pattern of decorative grooves carved on the columns. In addition, red and blue statues of Yaksa (a demonic deity) are enshrined as guardians in small enclosures at both sides of the front of the gate, while white and ultramarine statues of Yaksa are enshrined in enclosures at the back of the gate.

**The Taiyû-in Reibyô Kôkamon (C32)** is a whitewashed gate with an arched entrance, traditionally associated with the image of the gate to the mythological "Palace of the Dragon King". Unusual workmanship was exercised in the plastering techniques of the wainscots, whose brilliant whiteness was realized by mixing lead oxide with the pigments.

#### **Site (Cultural Landscape)**

The nominated property as it exists today came into completion in the early Edo Period with the erection of Tôshôgû, the shrine containing the mausoleum

of the ancient Japanese. As such, the landscape has been nurtured by the local people and transmitted unchanged from the old days to this day; the designation of the Nikko Sannai area as Nikko National Park in 1934 was a recent act of protection in the line of the long history of continuous effort.

**Appendix 4: inventory of the cultural assets; copies of the official designation notices**

**4a: inventory of the buildings (National Treasures and Important Cultural Properties) included in the nominated property**

**4b: copies of the official notices**

**Appendix 5: drawings of the major buildings (National Treasures and Important Cultural Properties)**

b. History

The following is a brief description of the history of the nominated property, as old as the history of Nikko itself -- cultivated by many generations, ever since a Buddhist priest started religious activities in the Nikko Mountains in the late 8<sup>th</sup> century.

**[Nara Period ~ Heian Period: early 8<sup>th</sup> century to late 12<sup>th</sup> century]**

The area around the Nikko Mountains had long been a special place for Buddhist priests as sacred mountains suitable for their practice of asceticism to improve themselves spiritually.

However, it was not until the late 8<sup>th</sup> century that the area became an active place for systematic religious activities: in 782 a high-ranking Buddhist priest named Shôdô climbed Mt. Nantaisan for the first time in his life, and he erected a temple there two years later, marking the establishment of the Nikko Mountains as a definite religious place. It was also the start of the history of Nikko City, which would develop continuously to this day in close association with the sacred mountains revered by those who worship Kami, the deity of



Japan. Nikko was no exception to this overwhelming wave of historical transition, and had to weather through a time of temporary deterioration: in 1590 most of the territory was confiscated by Toyotomi Hideyoshi, who had completed the national struggle for reunification.

**[Edo Period: 17<sup>th</sup> century to middle 19<sup>th</sup> century]**

Restoration of the shrines and temples of Nikko started in the Edo Period under the supervision of the Buddhist high priest Tenkai, who was also an aide to Tokugawa Ieyasu, the founder of the Tokugawa shogunate.

Nikko, which had been revered in association with the custodian deity of the Kanto Area, took on another kind of status of political significance after the remains of Tokugawa Ieyasu (d. 1616) and Tokugawa Iemitsu (d. 1651), the third shogun, were enshrined there in 1617 and in 1651, respectively.

The nominated property, containing the mausoleums enshrining the founders of the longest-reigning government in Japan, received devoted and unsparing care from the Tokugawa government.

Thus Nikko became the destination of pilgrimage not only for local powers subordinate to the Tokugawa government but also for succeeding shoguns in following generations (their pilgrimage counted 19 times in total). Even the imperial court in Kyoto sent its envoy continuously for 121 years and overseas delegates from the Korean Yi Dynasty visited there, three times in total, as a symbolic act demonstrating their good intentions to the Tokugawa government.

In this way, the nominated property played a significant role in terms of the political history of Japan, as a symbol of the sovereignty of the Tokugawa government throughout the nation.

Tôshôgû was constructed in 1617 as the mausoleum dedicated exclusively to enshrine the remains of Tokugawa Ieyasu, while the Taiyû-in Reibyô was erected in 1653 in order to enshrine the remains of Tokugawa Iemitsu. Tôshôgû was later remodeled during the period from 1634 to 1636.

On the other hand, there were people who recognized the urgent need to protect these cultural assets and who took the initiative to organize an association named Hokōkai in 1879 for the conservation of shrines and temples in Nikko. They soon instituted a program of repair work in an organized manner.

In 1897, the national government enacted the Ancient Shrines and Temples Preservation Law and the national government and the owners of Futarasan-jinja, Tōshōgū and Rinnō-ji organized an official office for the repair of shrines and temples in Nikko in order to carry out repair work for the religious buildings on a professional level.

In 1929, this law was revised into the National Treasures Preservation Law, which covered a wider range of cultural assets for preservation. Meanwhile, the Law for the Preservation of Historic Sites, Places of Scenic Beauty and Natural Monuments was newly legislated in 1919. These two laws were later consolidated in 1950 to form the Law for the Protection of Cultural Properties, which provides the legal framework for the protection of cultural assets in Japan today. Under this law and other applicable laws and regulations, various administrative measures are implemented in Nikko for the purpose of passing on the nominated property to future generations in a good state of conservation.

In 1931, the National Parks Law was enacted and the Nikko National Park was established in 1934 under the law. Later in 1938, the Special Area was designated, followed by the designation of the Special Protection Area in 1953. Since then it has been protected and conserved in good condition to the present day.

**Appendix 6: chronological table of Nikko in relation to the nominated property**

"Honden" and 5 other buildings]. Futarasan-jinja, 1981.

**b. On Tōshōgū** (in order of publication)

*Kokuhō Tōshōgū Honden Haiden Fuzoku Makie Tobira Shūrikōji Hōkokusho* [Documentation on the Restoration of lacquerwork on the doors of the National Treasures of Tōshōgū, "Honden" and "Haiden"]. Tōshōgū, 1965.

*Kokuhō Tōshōgū Omotemon, Shinkyū, Suibansha Shūrikōji Hōkokusho* [Documentation on the Restoration of the National Treasures of Tōshōgū, "Omotemon", "Shinkyū" and "Suibansha"]. Tōshōgū, 1965.

*Jūyō Bunkazai Tōshōgū Kaguraden, Kami-naka-shimo-jinko, Otabisho Shaden, Kariden Shōrō Sonota Shūrikōji Hōkokusho* [Documentation on the Restoration of the Important Cultural Properties of Tōshōgū, "Kaguraden", "Kamijinko", "Nakajinko", "Shimojinko", "Otabisho Shaden" and "Kariden Shōrō"]. Tōshōgū, 1967.

*Kokuhō Tōshōgū Honden, Ishinoma, Haiden Shūrikōji Hōkokusho* [Documentation on the Restoration of the National Treasure of Tōshōgū, "Honden, Ishinoma and Haiden"]. Tōshōgū, 1967.

*Kokuhō Tōshōgū Karamon, Sukibē Shūrikōji Hōkokusho* [Documentation on the Restoration of the National Treasures of Tōshōgū, "Karamon" and "Sukibē"]. Tōshōgū, 1967.

*Jūyō Bunkazai Honjidō Shūrikōji Hōkokusho* (I, II) [Documentation on the Restoration of the Important Cultural Property of Tōshōgū, "Honjidō" (I, II)]. Tochigi Prefecture, 1968.

*Jūyō Bunkazai Tōshōgū Okusha Haiden, Okusha Torii, Okusha Dōjinko, Okusha Karamon, Hijōmon, Dōkomon Shūrikōji Hōkokusho* [Documentation on the Restoration of the Important Cultural Properties of Tōshōgū, "Okusha Haiden", "Okusha Torii", "Okusha Dōjinko", "Okusha Karamon", "Hijōmon" and "Dōkomon"]. Tōshōgū, 1972.

*Kokuhō Tōshōgū Yōmeimon, Dō Sayū Dodebē Shūrikōji Hōkokusho* [Documentation on the Restoration of the National Treasures of Tōshōgū, "Yōmeimon" and "Sodebē"]. Tōshōgū, 1974.

*Kokuhō Jūyō Bunkazai Tōzai Kairō, Sakashitamon, Saijō Shūrikōji Hōkokusho* [Documentation on the Restoration of the National Treasure and Important Cultural Properties of Tōshōgū, "Tōzai Kairō", "Sakashitamon" and "Saijō"]. Tōshōgū, 1975.

*Jūyō Bunkazai Kyōzō, Korō, Shōrō Shūrikōji Hōkokusho* [Documentation on the Restoration of the Important Cultural Properties of Tōshōgū, "Kyōzō", "Korō" and "Shōrō"]. The Foundation for the Preservation of Shrines and

Rinnô-ji, 1975.

*Shaden III* [Shrine buildings III]. Chuo Koron Bijutsu Shuppan, 1981. Vol. 3 of *Nihonkenchiku-shi Kisoshiryô Shûsei* [Basic Bibliography of Japanese Architectural History].

*Jûyô Bunkazai Rinnô-ji Hokkedô, Jôgyôdô Hokkedô Watarirô, Taiyû-in Reibyô Hôko Shûrikôji Hôkokusho* [Documentation on the Restoration of the Important Cultural Properties of Rinnô-ji, "Hokkedô", "Jôgyôdô Hokkedô Watarirô" and "Taiyû-in Reibyô Hôko"]. Rinnô-ji, 1981.

*Jûyô Bunkazai Rinnô-ji Taiyû-in Reibyô Nitemmon Shûrikôji Hôkokusho* [Documentation on the Restoration of the Important Cultural Property of Rinnô-ji, "Taiyû-in Reibyô Nitemmon"]. Rinnô-ji, 1986.

iii) Research papers etc.

Bird, Isabella. *Unbeaten Tracks in Japan. An Account of Travels in the Interior, Including Visits to the Aborigines of Yezo, and the Shrines of Nikko and Ise.* 1880.

Okawa, Naomi. *Edo Architecture: Katsura and Nikko.* Charles E Tuttle Co., 1975.

In addition, there are descriptions related to the nominated property not only in most text books of Japanese history used in Japan but also in a number of encyclopedias published throughout the world, which are listed below.

**a. Working languages of the United Nations**

**Chinese language**

*中国大百科全书* [Great Chinese Encyclopedia: World Geography]. 中国大百科全书出版社, 1978, written in Chinese.

**English language**

*The New Encyclopedia Americana, International Edition.* Grolier Incorporated, 1995, written in English.

*The New Encyclopædia Britannica.* Encyclopedia Britannica Inc. 1991, written in English.

**French language**

*Grand Dictionnaire Encyclopédique Larousse.* Libraire Larousse 1984, written in French.

d. Present state of  
conservation

The national government and local governments are taking strong measures to protect the value of the group of buildings included in the nominated property, as provided under the Law for the Protection of Cultural Properties.

Those buildings have been maintained in a good state of conservation through adequate repair work since their foundation in the early Edo Period; every time any kind of damage or deterioration occurred, as a result of either man-made or natural causes, the damaged elements were restored to the original form and design on the basis of written records or documents. As a result of such efforts for conservation, these buildings have been so well preserved that there are no buildings left that need large-scale repair except for a few constructions including the Shinkyō and the Sanjūnotō.

Although wooden buildings in Japan, climatically characterized by high temperature and high humidity, are normally exposed to the risk of deterioration and damage caused by fungi, insects, or rain, the buildings included in the nominated property have been successfully conserved in good condition through appropriate applications of repair work to roofing materials, refreshment of painting, and replacement of decayed members.

As for buildings for which thorough repair work has been conducted, regular maintenance work such as painting repair or decay prevention is conducted at appropriate intervals.

In addition, a master plan for repair work and management activities is laid out in order to coordinate and prioritize related conservation work and it is thereby ensured that the more damaged areas be treated prior to those in less need of treatment.

A brief history of the repair work already carried out on the nominated property is given below:

What is the most distinctive factor about the repair work for the shrines and temples of Nikko is that major attention is focused upon the richly colored decoration on the exterior of the architecture. Japan lacquer and paint finishes are renewed at regular intervals with traditional materials and techniques. Furthermore, the Ministry of Education of Japan has designated this technique for preservation as a Traditional Conservation Technique, indispensable for the conservation of cultural properties. The Foundation for the Preservation of Shrines and Temples of Nikko, being the officially recognized Holder of the Traditional Conservation Technique, holds training seminars on a practical level every year with financial support from the national government, in order to educate those directly involved in repair work of the traditional architecture at Nikko as well as those involved in such work anywhere in Japan. This contributes to ensuring that the traditional conservation technique associated with the nominated property will be securely preserved and passed on to future generations.

On the other hand, the forests containing this group of buildings have distinctive characteristics and universal value as sacred mountains which have been revered by generations of devout people as a religious sanctuary. Those forests are the way they are as a result of the religiously-charged activity of forestation that has been carried out in association with the shrines and temples included in the nominated property. Records tell that people had already started forestation work there as early as in the 15<sup>th</sup> century and that trees were planted in commemoration when Tōshōgū and the Taiyū-in were erected. As a result, the group of religious buildings and the natural setting nurtured by human activities form a distinctive cultural landscape as an inseparable unit. Clearly heterogeneous to the urban areas spreading around them, the forests and the group of religious buildings produce a serene, supreme space for spiritual activity -- a setting which has been maintained from the time of their foundation.

protected as a National Park area, in which various actions are prohibited without following due procedure of advanced notification or permission application.

It is the policy of the national government of Japan to continue the present policies and programs mentioned above, thereby to ensure that the protection and promotion of the nominated property be conducted in an effective and integrated manner.

As for presentation of the nominated property, the buildings included in the property and most of the areas in which they are located are open to the public throughout the year. In addition, a number of the owners go further, setting up displays of some of the historic materials or fine works of arts and crafts under their custody. These efforts have contributed greatly to the presentation and promotion of the nominated property and will continue to do so.

**Appendix 13: plans indicating locations of support facilities and facilities for visitors**

## *4. Management*





#### 4. Management

##### a. Ownership

Ownership of the nominated property is shown in Table 1.

**Table 1: Owners and Locations of the Nominated Property**

Category of "cultural heritage"	Owner	Location
The <i>group of buildings</i> included in the nominated property	Futarasan-jinja; Tôshôgû; Rinnô-ji	Sannai, Nikko City; Kamihatsuishimachi, Nikko City;
The <i>site</i> included in the nominated property (cultural landscape)	Nikko City; Futarasan-jinja; Tôshôgû; Rinnô-ji; Shôson-in	Yasugawa-chô, Nikko City.

##### b. Legal status

The one hundred and three buildings included in the nominated property are designated as National Treasures or Important Cultural Properties under Article 27 of the Law for the Protection of Cultural Properties (promulgated on May 30, 1950, combining the former 1919 and 1929 laws; the original law was enacted in 1897) (hereinafter referred to as the "designated buildings").

The areas where the buildings are located are designated as Historic Sites under Article 69 of the Law (hereinafter referred to as the "designated areas"; see Appendix 4 for the inventory of the cultural assets included in the nominated property and the copies of the official designation notices).

Detailed information regarding the designated buildings and areas is given in Table 2.

In principle, it is the owners of the designated buildings or areas who manage, repair and open them to the public (under Articles 30, 31, 34-2, 47-2, 74 and 75). Alterations to the existing state of designated buildings or areas are legally restricted, and any such alteration requires the permission of the national government (under Articles 43 and 80).

**Additional reference material 1: laws and regulations**

**1a: the Law for the Protection of Cultural Properties**

**1b: the Natural Parks Law (excerpt)**

**1c: the Nikko City Municipal Ordinance Concerning Townscape**

**1d: the Preservation Management Plan for the Nikko Sannai Historic Site (excerpt)**

**1e: the Management Plan for Nikko National Park (Nikko District) (summary)**

c. Protective measures  
and means of  
implementing them

i) The Nominated Property

The group of buildings included in the nominated property are protected and preserved on property as National Treasures or Important Cultural Properties designated by the national government (the Agency for Cultural Affairs) under the Law for the Protection of Cultural Properties. In addition, the areas where those buildings are located are regulated regionally as Historic Sites under the same law and the Special Protection Area, Special Area or Ordinary Area of Nikko National Park under the Natural Parks Law. The regulations cover not only the group of buildings in question but also the buried archeological remains underground. In the area designated as National Park area, actions with adverse impact upon scenic beauty of the landscape are prohibited without prior permission from the Environment Agency of Japan. In addition, the Environment Agency is responsible for the implementation of regulations and the issuance of instructions to ensure compliance with the management plan of Nikko National Park.

As part of protective measures for the nominated property, much attention is given to fire prevention in consideration of the fact that the property consists of wooden construction for the most part.

To be specific, all of the buildings designated as National Treasures or Important Cultural Properties have already been equipped with automatic fire alarm systems, and protected further with fire extinguishing systems and

	<p style="text-align: center;"><b>nominated property and the buffer zones</b></p> <p style="text-align: center;">(See also Appendix 3a: maps indicating the extent of the nominated property and the buffer zone with indication of the zones of legal protection)</p>
<p>d. Agencies with management authority</p>	<p><b>Agency for Cultural Affairs</b> 3-2-2 Kasumigaseki, Chiyoda-ku, Tokyo</p> <p><b>Environment Agency</b> 1-2-2 Kasumigaseki, Chiyoda-ku, Tokyo</p>
<p>e. Level at which management is exercised and name and address of responsible person for contact purposes</p>	<p>Ordinary maintenance and management of the buildings included in the nominated property is the responsibility of the owners and is carried out at their disposition. On the other hand, legal provisions require that even owners need to notify the Agency for Cultural Affairs in advance in order to carry out any repair work other than day-to-day maintenance work or temporary repair work (the Law for the Protection of Cultural Properties). This system is intended to maintain the high standard of conservation technique with technical support from the national government.</p> <p>The names and addresses of responsible persons for contact purposes are listed in Chapter 6. (See Annexed Table 1-1.)</p>
<p>f. Agreed plans related to property</p>	<p>Construction work for sand erosion control of the river basins is planned in the Inarigawa River area, which is outside the nominated area but included in the buffer zone. The purpose of this project is primarily to protect the living environment for the inhabitants in the river-basin area from sand-caused disasters such as mudflows or debris flows, and at the same time to do so without impairing the natural environment and the built environment of historic value</p>

Preservation of Shrines and Temples of Nikko, the organization designated by the national government as the Holder of the Designated Traditional Conservation Technique (painting technique), holds seminars to conserve the traditional conservation technique itself and to educate young technicians.

Detailed information regarding the staff, the training and the financial system is given in Chapter 6. (See Annexed Table 1-4.)

i. Visitor facilities and statistics

The nominated property is part of the magnificent natural environment characteristic of Nikko National Park, which has long been famous for its outstanding scenic beauty, attracting great numbers of sightseers from throughout Japan.

Approximately 1.7 million tourists visit Nikko every year, of whom about 550,000 are students from all over Japan on study tours as part of their school curriculum every year and about 20,000 are tourists from outside of Japan. Nikko is widely known not only to those living in Japan -- it is also an internationally-renowned sightseeing destination.

For the convenience of tourists, visitor facilities are available in the area included in the nominated property, including explanation signboards, museums and art museums, car parking, lavatories and shops. Overnight accommodations, restaurants and car parking are available in the areas which are proposed as the buffer zone.

**Appendix 13: plan indicating locations of support facilities and facilities for visitors**

j. Property management plan and statement of objectives

Alterations to the existing state of the nominated property are regulated through legal instruments mentioned earlier in this chapter; specific policies of management are prescribed in the management plans listed below.

## *5. Factors Affecting the Property*



**5. Factors Affecting the  
Property**

a. Development pressures

The government of Nikko City plans to develop this general area into an internationally-oriented resort area complete with the enchantments of a traditional cultural city.

In the process of achieving this vision, it can naturally be expected that some older buildings will be replaced with new ones in the central part of the city. However, in order to continuously enhance the standards of urban life without impairing the historic and esthetic value of the traditional environment, any future construction activities are to be carefully planned through effective enforcement of the Natural Parks Law and the city planning codes regulating land use, building height and design quality. Therefore, this development would not undermine the value of the nominated property.

b. Environment pressures

Environmental pressures anticipated in the relevant region include dust pollution, air pollution, and acid rain or acid fog, all of which are monitored at regular intervals. When judged to be necessary on the basis of the monitored data, cleaning is carried out to remove dust and reduce the impact of other pollutants. Therefore, there are no clear and present environmental pressures that would undermine the value of the nominated property.

c. Natural disasters and  
preparedness

Major natural disasters which could occur in the relevant region include severe storms, flash floods and earthquakes. For the purpose of mitigating the adverse effects of these disasters, the nominated area has been provided with drainage systems and concentrated forestation has been carried out to help provide protection against strong wind and landslides.

## *6. Monitoring*

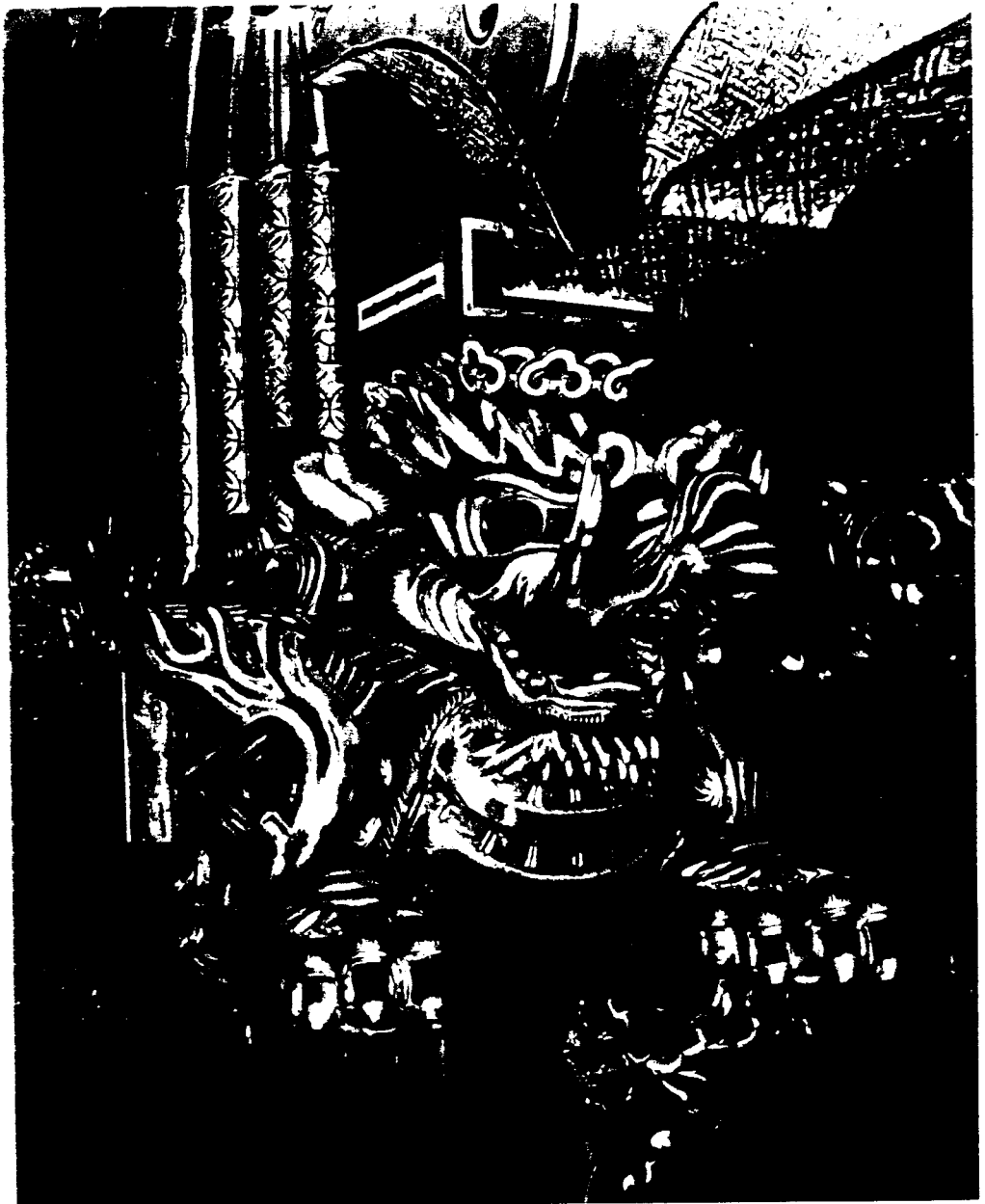

## 6. Monitoring

### a. Key indicators for measuring state of conservation

The uniqueness of the nominated property consists in the magnificent designs replete with sculpture, painting and other color finishes, metal fittings and so forth. These works of painting and other decorating techniques have been maintained in an acceptably good state of conservation through excellent workmanship faithfully transmitted from generation to generation ever since the Edo Period. In addition, the cultural landscape produced by this beautiful religious architecture in harmony with the lush green natural setting around it is another distinctive feature of the nominated property.

In order to conserve such a cultural property in modern society and to transmit it to following generations, it is essential to secure staff and systems for diverse application and transmission of traditional techniques and at the same time to plan and conduct programs of scientific research on the causes of decay or deterioration and to make periodical review and improvement of the preservation management plans. In addition, in order to protect the nominated property and the natural setting around it as a unit, it is important that all related agencies and other organizations, recognizing their own roles, make devoted efforts to strengthen the network of communication and cooperation.

The nominated property and the buffer zone will be monitored periodically and systematically and the state of conservation will be constantly checked in order to judge whether there is a need to improve or reinforce the techniques and organizations for conservation, repair, restoration, management, disaster prevention and risk control.

The monitoring will be conducted according to the three indicators listed below. Specific items for measurement are given in Annexed Table 1.

**Key Indicator 1:** the state of conservation in terms of the significance of the



Preservation for Shrines and Temples of Nikko and other related organizations or interested groups under the instruction of the Tochigi Prefectural Board of Education, the Environment Agency, and the Agency for Cultural Affairs. (See item 1-c) of Annexed Table 1 for details.)

In accordance with Paragraph 70 of the Operational Guidelines for the Implementation of the World Heritage Convention (1997), the condition of the property will be recorded every fiscal year and a report will be compiled every five years and submitted (in English) to the World Heritage Committee via the UNESCO World Heritage Centre.

c. Results of previous reporting exercises

Reports of conservation repair work conducted for National Treasures and Important Cultural Properties are listed in Annexed Table 3.

(Annexed Table 1. Items for measurement of key indicators 1, 2 and 3.)

Category	Sub-category	Target	Index
1) Management	b) Fire prevention	Nominated property	<p>1. Persons in charge of fire prevention and leaders of fire fighting squads. Fire Office of Nikko City Person in charge: head of the office (TAMURA Masao)</p> <p>Futarasan-jinja Person in charge: NAKAMARO Terumi. Leader of fire fighting squad: YOSHIDA Takehiko.</p> <p>Tōshōgū Person in charge: SUZUKI Takatoshi. Leader of fire fighting squad: INABA Hisao.</p> <p>Rinnō-ji Person in charge: NAKAZATO Shōnen. Leader of fire fighting squad: SUZUKI Jōshun.</p> <p>The Foundation for the Preservation of Shrines and Temples of Nikko Person in charge: TAKAHASHI Toshio.</p>
	c) Monitoring	Nominated property and buffer zone	<p>1. Organization in charge of monitoring: Organization: the Nikko Municipal Board of Education. Representative: head of the department of education (HOMMA Masakazu). Staff in charge: technical expert of the social education division (OKABE Nobuo) director of the social education division (ŌTA Kuntio) Address: 4-1 Gokō-machi, Nikko City, Tochigi Prefecture.</p> <p>2. Supervising organization: Organization: the Agency for Cultural Affairs. Representative: commissioner (HAYASHIDA Hideki). Staff in charge: director of the architecture division (MURAKAMI Jinichi); director of the monuments and sites division (SOWAKI Hiroshi). Address: 3-2-2 Kasumigaseki, Chiyoda-ku, Tokyo.</p> <p>3. Advisory organization: Organization: the Tochigi Prefectural Board of Education. Representative: head of the department of education (KOGUCHI Norio). Staff in charge: director of the cultural properties division (NAGASHIMA Shigeo). Address: 1-1-20 Hanawada, Utsunomiya City, Tochigi Prefecture.</p> <p>4. Cooperating organizations or persons: Futarasan-jinja (a religious organization), Tōshōgū (a religious organization), Rinnō-ji (a religious organization) and the Foundation for the Preservation of Shrines and Temples of Nikko.</p>

(Annexed Table 1. Items for measurement of key indicators 1, 2 and 3.)

Category	Sub-category	Target	Index
3) State of conservation of the buffer zone	a) State of conservation	Natural environment etc.	<ol style="list-style-type: none"> <li>1. Environmental pressures.</li> <li>2. Natural disasters.</li> <li>3. Visitor / tourism pressures.</li> <li>4. Other. (Human impact etc.)</li> </ol>
	b) Alteration to the existing state	National Park, Scenic Zone, Reserved Forest and areas regulated by the Nikko Municipal Ordinance Concerning Townscape	<ol style="list-style-type: none"> <li>1. Construction work by private corporations regulated under applicable laws and regulations.</li> <li>2. Public works.</li> </ol>
4) Conservation and transmission of conservation techniques	a) Seminars and on-site training etc.	Painting technique, woodwork etc.	<ol style="list-style-type: none"> <li>1. Date of the seminar / training.</li> <li>2. Host / sponsor.</li> <li>3. Content.</li> <li>4. Participants / trainees.</li> <li>5. Number of participants.</li> <li>6. Cost.</li> <li>7. Availability of reports.</li> </ol>
	b) Designation of traditional conservation techniques under the Law for the Protection of Cultural Properties	Engineers engaged in conservation work of the nominated property	<ol style="list-style-type: none"> <li>1. Name of the holder of the designated traditional conservation technique.</li> <li>2. Assistance and support for the conservation of the designated traditional conservation technique.</li> <li>3. Availability of records on the designated traditional conservation technique.</li> </ol>

**Annexed Table 3. List of the Reports of Conservation Repair Work Conducted for National Treasures and Important Cultural Properties.**

*Futarasan-jinja Shinkyô Hozonshûrikôji Hôkokusho (1950-1957)* [Documentation on the Conservation Repair Work on the Shinkyô of Futarasan-jinja (1950-1957)].

*Futarasan-jinja Honden, Haiden Hozonshûrikôji Hôkokusho (1952-1958)* [Documentation on the Conservation Repair Work on the Honden and the Haiden of Futarasan-jinja (1952-1958)].

*Futarasan-jinja Torii, Chûgûshi Honden, Betsugû Hongû-jinja Honden Hozonshûrikôji Hôkokusho (1950-1967)* [Documentation on the Conservation Repair Work on the Torii, the Chûgûshi Honden and the Betsugû Honden-jinja Honden of Futarasan-jinja (1950-1967)].

*Futarasan-jinja Chûgûshi Honden and Haiden (1969-1970)* [Documentation on the Chûgûshi Honden and Haiden of Futarasan-jinja (1969-1970)].

*Futarasan-jinja Betsugû Takino-o-jinja Honden, Karamon, Haiden, Rômon, Massha Mitomo-jinja Honden, Massha Hie-jinja Honden, Betsugû Hongû-jinja Haiden, Honsha Honden Hoka 5 Mune Hozonshûrikôji Hôkokusho (1957-1981)* [Documentation on the Conservation Repair Work on the Betsugû Takino-o-jinja Honden, the Karamon, the Haiden, the Rômon, the Massha Mitomo-jinja Honden, the Massha Hie-jinja Honden, Betsugû Hongû-jinja Haiden, the Honden and 5 other buildings of Futarasan-jinja (1957-1981)].

*Tôshôgû Omotemon, Shinkyû, Suibansha Hozonshûrikôji Hôkokusho (1950-1952)* [Documentation on the Conservation Repair Work on the Omotemon and the Miyuza of Tôshôgû (1950-1952)].

*Tôshôgû Honden, Haiden, Fuzoku Makietobira Hozonshûrikôji Hôkokusho (1955-1964)* [Documentation on the Conservation Repair Work on the Honden and the Haiden of Tôshôgû (1955-1964)].

*Tôshôgû Honden, Ishinoma, Haiden (1951-1958)* [Documentation on the Honden, Ishinoma and Haiden of Tôshôgû (1951-1958)].

*Tôshôgû Karamon, Sukibê (1956-1961)* [Documentation on the Karamon and Sukibê of Tôshôgû (1956-1961)].

*Tôshôgû Kaguraden, Kamijinko, Nakajinko, Shimojinko, Otabisho, Shaden, Kariden, Shûrô Shûrikôji Hôkokusho (1950-1967)* [Documentation on the Restoration of the Kaguraden, the Kamijinko, the Nakajinko, the Shimojinko, the Otabisho, the Shaden, the Kariden and the Shûrô of Tôshôgû (1950-1967)].

*Tôshôgû Okusha Haiden, Okusha Torii, Okusha Dôjinko, Okusha Karamon, Tsuketari Hijômon, Tsuketari Dôjinko Hozonshûrikôji Hôkokusho (1967-1970)* [Documentation on the Conservation Repair Work on the Okusha Haiden, the Okusha Torii, the Okusha Dôjinko, the Okusha Karamon, the Hijômon and the Dôjinko of Tôshôgû (1967-1970)].

*Tôshôgû Yômeimon Hozonshûrikôji Hôkokusho (1969-1973)* [Documentation on the Conservation Repair Work on the Yômeimon of Tôshôgû (1969-1973)].

*Tôshôgû Shin-yosha, Omotemon Hoka Hozonshûrikôji Hôkokusho (1975-1981)* [Documentation on the Conservation Repair Work on the Shin-yosha and the Omotemon of Tôshôgû (1975-1981)].

*Tôshôgû Kariden Honden, Ainoma Haiden, Kariden Karamon, Kariden Wakimon Oyôbi Sukebê Hozonshûrikôji Hôkokusho (1981-1985)* [Documentation on the Conservation Repair Work on the Kariden Honden, Ainoma and Haiden, the Kariden Karamon and the Kariden Wakimon and Sukebê of Tôshôgû (1981-1985)].

*Rinnô-ji Hondô (Sambutsudô) Hozonshûrikôji Hôkokusho (1954-1961)* [Documentation on the Conservation Repair Work on the Hondô (Sambutsudô) of Rinnô-ji (1954-1961)].

## *7. Documentation*

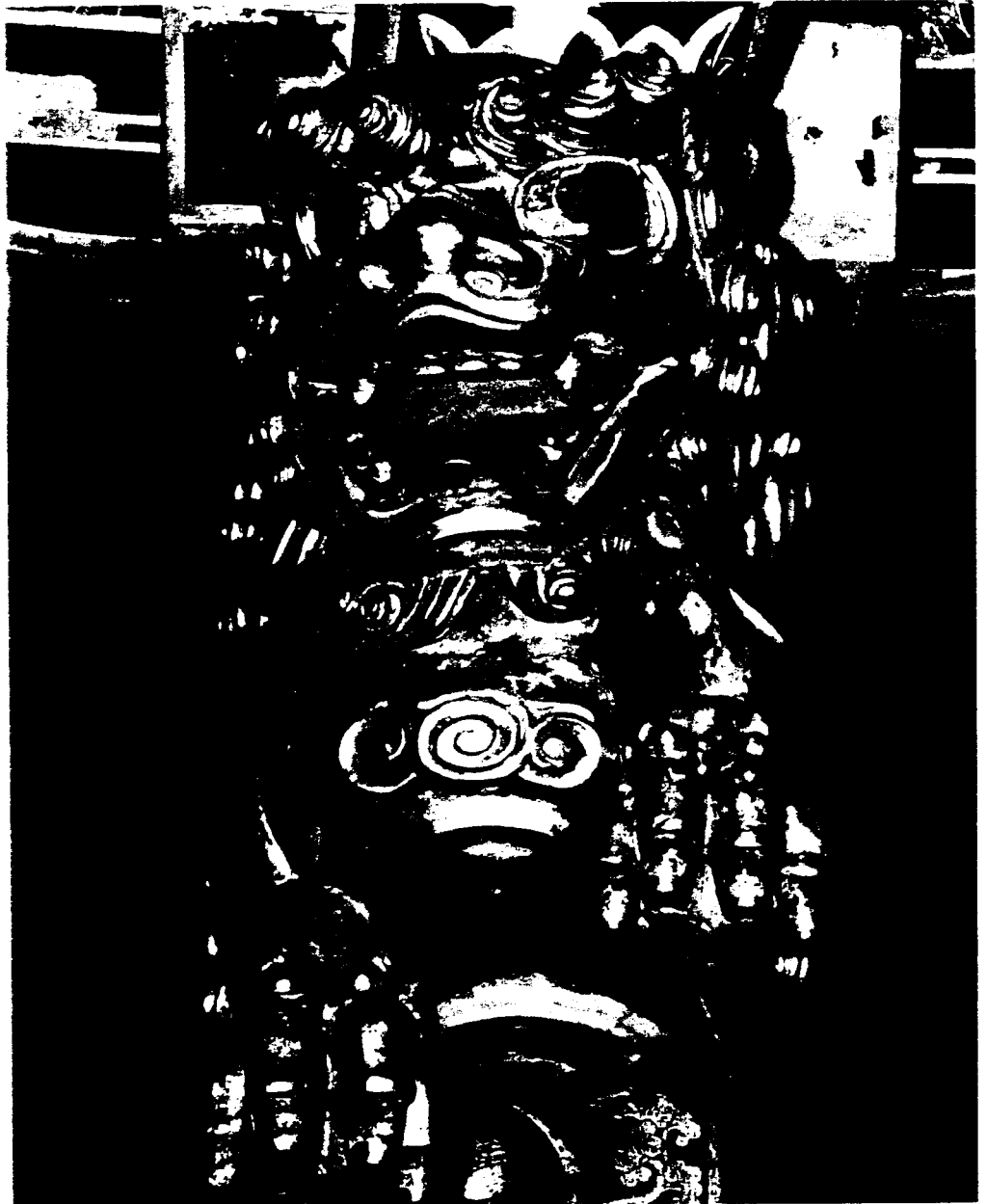

**7. Documentation**

a. Photographs, slides and video

**Appendix 14: list of photographs**

**Appendix 15: photographs and maps indicating the places where the photographs were taken (taken in November and December 1997)**

**Additional reference material:**

color slides (taken in November and December 1997; copyright agreement attached)

**Additional reference material:**

videotape production (filmed in December 1997)

b. Copies of property management plans and extracts of other plans relevant to the property

*The Preservation Management Plan for the Nikko Sannai Historic Site.*  
Nikko Municipal Board of Education, 1998.

*The Management Plan for Nikko National Park (Nikko District).*  
Environment Agency, 1997.

c. Bibliography

Nikko Tōshōgū. *Kokuhō Tōshōgū Yōmeimon* [the Yōmeimon of Tōshōgū: National Treasure]. Nikko Tōshōgū, 1974.

d. Address where inventory, records and archives are held

**Agency for Cultural Affairs**

3-2-2 Kasumigaseki, Chiyoda-ku, Tokyo

**Environment Agency**

1-2-2 Kasumigaseki, Chiyoda-ku, Tokyo

**North-Kanto Regional National Parks and Wildlife Office**

9-5 Hon-chō, Nikko City, Tochigi Prefecture

**Tochigi Prefectural Board of Education**

1-1-20 Hanawada, Utsunomiya City, Tochigi Prefecture

**Nikko Municipal Board of Education**

999 Nakahatsuishimachi, Nikko City, Tochigi Prefecture

**Foundation for the Preservation of Shrines and Temples of Nikko**

2281 Sannai, Nikko City, Tochigi Prefecture

**Futarasan-jinja**

2307 Sannai, Nikko City, Tochigi Prefecture

**Tōshōgū**

2301 Sannai, Nikko City, Tochigi Prefecture

**Rinnō-ji**

2300 Sannai, Nikko City, Tochigi Prefecture

8. *Signature on behalf of the State Party*



Signed on behalf of the Government of Japan

林 田 英 樹

HAYASHIDA Hideki

Commissioner  
Agency for Cultural Affairs

丸 山 晴 男

MARUYAMA Haruo

Director General  
Nature Conservation Bureau,  
Environment Agency

Government of Japan

June 22, 1998



AUTHORIZATION

1. I, KUNIO HANEISHI.....  
the undersigned, hereby grant free of charge to Unesco the non-exclusive right for the legal term of copyright to reproduce and use in accordance with the terms of paragraph 2 of the present authorization throughout the world the photograph(s) and/or slide(s) described in paragraph 4.
2. I understand that the photograph(s) and/or slide(s) described in paragraph 4 of the present authorization will be used by Unesco to disseminate information on the sites protected under the World Heritage Convention in the following ways:
  - a) Unesco publications;
  - b) co-editions with private publishing houses for World Heritage publications (a percentage of the profits will be given to the World Heritage Fund);
  - c) postcards - to be sold at the sites protected under the World Heritage Convention through national parks services or antiquities (profits, if any, will be divided between the services in question and the World Heritage Fund);
  - d) slide series - to be sold to schools, libraries, other institutions and eventually at the sites (profits, if any, will go to the World Heritage Fund);
  - e) exhibitions, etc.
3. I also understand that I shall be free to grant the same rights to any other eventual user but without any prejudice to the rights granted to Unesco.
4. The photograph(s) and/or slide(s) for which the authorization is given include:(Please describe photographs and give for each a complete caption and the year of production or, if published, of first publication. Attach additional sheets, if necessary.)

Additional sheets (three in total) are attached.

---



---



---



---

5. All photographs and/or slides will be duly credited. The photographer's moral rights will be respected. (Please indicate the exact wording to be used for the photographic credit.)

KUNIO HANEISHI

6. I hereby declare and certify that I am duly authorized to grant the rights mentioned in paragraph 1 of the present authorization.
7. I hereby undertake to indemnify Unesco, and to hold it harmless of any responsibility, for any damages resulting from any violation of the certification mentioned under paragraph 6 of the present authorization.
8. Any differences or disputes which may arise from the exercise of the rights granted to Unesco will be settled in a friendly way. Reference to courts or arbitration is excluded.

Nikko Japan  
Place

06/18/98  
date

KUNIO HANEISHI  
Signature, title or function of the person duly authorized

---

LIST OF PHOTOGRAPHS  
for which the authorization is given  
(Haneishi Kunio)

---

No.

---

- 9 Futarasan-jinja: the Haiden.  
10 Futarasan-jinja: the Honden.  
11 Futarasan-jinja: the Honden. Decoration beneath the eaves.  
12 Futarasan-jinja: the Shinkyô.  
13 Futarasan-jinja: the Shinkyô and the front approach.  
14 Futarasan-jinja: the Betsugû Takino-o-jinja Honden.  
15 Futarasan-jinja: the Betsugû Hongû-jinja Honden.  
16 Futarasan-jinja: the Shin-yosha.
- 17 Tôshôgû: the Honden, Ishinoma and Haiden and the Kairô. View from north.  
18 Tôshôgû: the Honden (side).  
19 Tôshôgû: the Ishinoma. The juncture of the Ishinoma and the Honden.  
20 Tôshôgû: the Honden. Interior. View from the Ishinoma.  
21 Tôshôgû: the Haiden. Interior.  
22 Tôshôgû: the Haiden. Interior (shogunal chamber).  
23 Tôshôgû: the Tôzai Sukibê and the Karamon.  
24 Tôshôgû: the Tôzai Sukibê. A latticed window.  
25 Tôshôgû: the Karamon, the Haiden and the Tôzai Sukibê (front).  
26 Tôshôgû: the Karamon.  
27 Tôshôgû: the Torii and the Yômeimon.  
28 Tôshôgû: the Yômeimon (front).  
29 Tôshôgû: the Yômeimon. Detail (pillar).  
30 Tôshôgû: the Yômeimon. Detail.  
31 Tôshôgû: the Tôzai Kairô.  
32 Tôshôgû: the Tôzai Kairô. Close-up of decoration.  
33 Tôshôgû: the Tôzai Kairô. Interior.
- 34 Tôshôgû: the Mizuya.  
35 Tôshôgû: the Mizuya. Close-up.  
36 Tôshôgû: the Shinkyû.  
37 Tôshôgû: the Ishidorii and the Gojûnotô.  
38 Tôshôgû: the Gojûnotô (front).  
39 Tôshôgû: the Ishidorii (front).  
40 Tôshôgû: the Sakashitamon (front).  
42 Tôshôgû: the Otabisho Honden.

---

LIST OF PHOTOGRAPHS  
for which the authorization is given  
(Haneishi Kunio)

---

No.

---

- 43 Rinnô-ji: the Taiyû-in Reibyô Haiden.  
44 Rinnô-ji: the Taiyû-in Reibyô Honden.  
45 Rinnô-ji: the Taiyû-in Reibyô Ainoma. Interior.  
46 Rinnô-ji: the Taiyû-in Reibyô Honden. Interior.  
47 Rinnô-ji: the Taiyû-in Reibyô Honden. Interior. Detail.  
48 Rinnô-ji: the Taiyû-in Reibyô Honden. Interior. Detail.  
49 Rinnô-ji: the Taiyû-in Reibyô Karamon.  
50 Rinnô-ji: the Taiyû-in Reibyô Yashamon.  
51 Rinnô-ji: the Taiyû-in Reibyô Nitemmon.  
52 Rinnô-ji: the Taiyû-in Reibyô Kôkamon.  
53 Rinnô-ji: the Hondô (Sambutsudô).  
54 Rinnô-ji: the Hondô (Sambutsudô). Interior.  
55 Rinnô-ji: the Kaizandô.  
56 Rinnô-ji: the Jôgyôdô.  
57 Rinnô-ji: the Hokkedô.  
58 Rinnô-ji: the Sanjûnotô.
- 59 Cistern.  
60 Fire drill.

---

## LIST OF SLIDES

for which the authorization is given  
(Haneishi Kunio)

---

No.

---

- S 31 Futarasan-jinja: the Haiden.  
S 32 Futarasan-jinja: the Honden.  
S 33 Futarasan-jinja: the Shinkyô.  
S 34 Futarasan-jinja: the Shinkyô and the front approach.  
S 35 Tôshôgû: the Honden, Ishinoma and Haiden and the Kairô. View from north.  
S 36 Tôshôgû: the Honden (side).  
S 37 Tôshôgû: the Ishinoma. The juncture of the Ishinoma and the Honden.  
S 38 Tôshôgû: the Haiden. Interior.  
S 39 Tôshôgû: the Haiden. Interior (shogunal chamber).  
S 40 Tôshôgû: the Tôzai Sukibê and the Karamon.  
S 41 Tôshôgû: the Karamon, the Haiden and the Tôzai Sukibê (front).  
S 42 Tôshôgû: the Karamon.  
S 43 Tôshôgû: the Torii and the Yômeimon.  
S 44 Tôshôgû: the Yômeimon (front).  
S 45 Tôshôgû: the Yômeimon. Detail (pillar).  
S 46 Tôshôgû: the Tôzai Kairô.  
S 47 Tôshôgû: the Mizuya.  
S 48 Tôshôgû: the Shinkyû.  
S 49 Tôshôgû: the Gojûnotô (front).  
S 50 Tôshôgû: the Ishidorii (front).  
S 52 Rinnô-ji: the Taiyû-in Reibyô Haiden.  
S 53 Rinnô-ji: the Taiyû-in Reibyô Honden.  
S 54 Rinnô-ji: the Taiyû-in Reibyô Honden. Interior.  
S 55 Rinnô-ji: the Taiyû-in Reibyô Honden. Interior. Detail.  
S 56 Rinnô-ji: the Taiyû-in Reibyô Karamon.  
S 57 Rinnô-ji: the Taiyû-in Reibyô Yashamon.  
S 58 Rinnô-ji: the Taiyû-in Reibyô Kôkamon.  
S 59 Rinnô-ji: the Hondô (Sambutsudô).  
S 60 Rinnô-ji: the Hondô (Sambutsudô). Interior.  
S 61 Rinnô-ji: the Sanjûnotô.

---

LIST OF PHOTOGRAPHS  
for which the authorization is given  
(The Foundation for the Preservation of Shrines and Temples of Nikko)

---

No.

---

- 61 Conservation repair work in progress at Tōshōgū (the Mizuya).  
62 Conservation repair work in progress at Tōshōgū (the Kamijinko).

---

LIST OF PHOTOGRAPHS  
for which the authorization is given  
(PREC Institute Inc.)

---

No.

---

- 1 The nominated property and the buffer zone. Aerial view.
- 2 The nominated property. Aerial view.
- 3 The nominated property and the buffer zone against the background of Mt. Nantaisan.  
View from southeast.
- 4 The nominated property and the buffer zone. View from southeast.
- 5 The nominated property and the buffer zone. View from southwest.
  
- 6 Futarasan-jinja, Tōshōgū and Rinnō-ji. View from southeast.
- 7 Futarasan-jinja and the Taiyū-in Reibyō of Rinnō-ji. View from northeast.
- 8 Tōshōgū and the front approach. View from south.
  
- 41 Tōshōgū: the Okusha Hôtō.

---

## LIST OF SLIDES

for which the authorization is given  
(PREC Institute Inc.)

---

No.

---

- S 1 The Location in Japan.
- S 2 The Location in the kanto Area.
- S 3 The Location in Nikko City.
- S 4 Map indicating the nominated property and the surrounding natural and built environment.
- S 5 Map indicating the nominated property and the surrounding natural and built environment.
- S 6 The extent of the nominated property and the buffer zone with indication of the zones of legal protection.
- S 7 The extent of the nominated property and the buffer zone with indication of the zones of legal protection.
- S 8 The distribution of main buildings included in the nominated property.
- S 9 The distribution of buildings designated as national treasures or important cultural properties.
- S 10 The distribution of buildings designated as national treasures or important cultural properties.
- S 11 The distribution of buildings designated as national treasures or important cultural properties.  
A : Futarasan-jinja
- S 12 The distribution of buildings designated as national treasures or important cultural properties.  
B : Tôshôgû
- S 13 The distribution of buildings designated as national treasures or important cultural properties.  
C : Rinnô-ji
- S 14 Drawings of the major buildings (national treasures and important cultural properties).  
B : Tôshôgû(Yômeimon)
- S 15 The plan of the fire prevention system.
- S 16 The plan of the fire prevention system.
- S 17 Map of the area relevant to agreed plans related to the nominated property.
- S 18 Chronological table of conservation work. A : Futarasan-jinja
- S 19 Chronological table of conservation work. B : Tôshôgû
- S 20 Chronological table of conservation work. C : Rinnô-ji
- S 21 Plan indicating location of the buildings for which conservation work has been completed.
- S 22 Plan indicating location of the buildings for which conservation work has been completed.
- S 23 Plan indicating location of the buildings for which conservation work has been completed.  
A : Futarasan-jinja
- S 24 Plan indicating location of the buildings for which conservation work has been completed.  
B : Tôshôgû
- S 25 Plan indicating location of the buildings for which conservation work has been completed.  
C : Rinnô-ji
- S 26 Plan indicating location of support facilities and facilities for visitors.
- S 27 Plan indicating location of support facilities and facilities for visitors.

---

## LIST OF SLIDES

for which the authorization is given  
(PREC Institute Inc.)

---

No.

---

- S 28 The nominated property and the buffer zone. Aerial view.
- S 29 Futarasan-jinja, Tōshōgū and Rinnō-ji. View from southeast.
- S 30 Tōshōgū and the front approach. View from south.
- S 51 Tōshōgū: the Okusha Hôtō.



## APPENDICES 1-13

# APPENDIX 1 - a

MAP INDICATING THE LOCATION  
OF THE NOMINATED PROPERTY : ◆

The Location in Japan

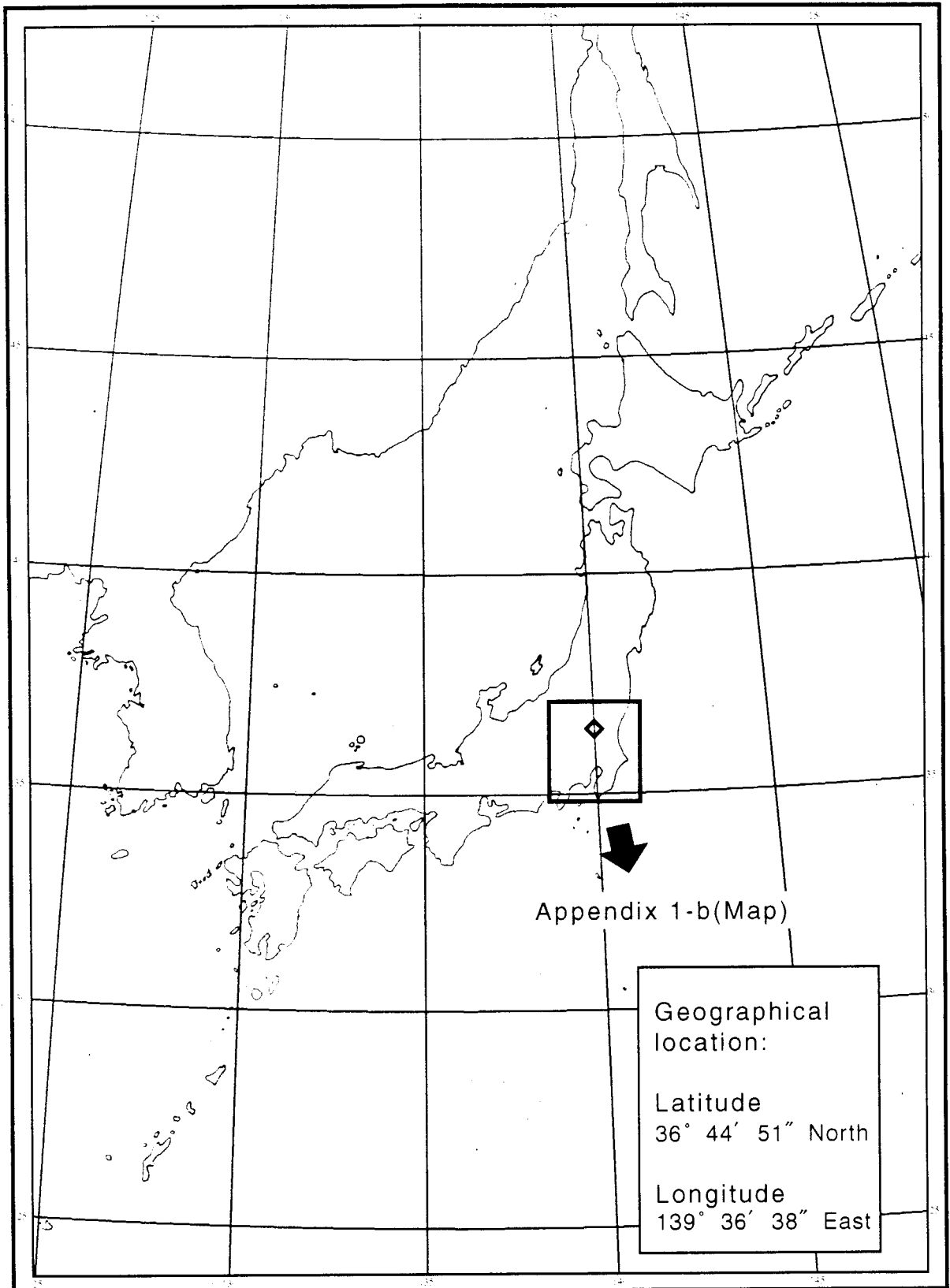

SCALE 1:15,000,000



**JAPAN / NIKKO**

# APPENDIX 1 - b

MAP INDICATING THE LOCATION  
OF THE NOMINATED PROPERTY : ◆

The Location in the Kanto Area

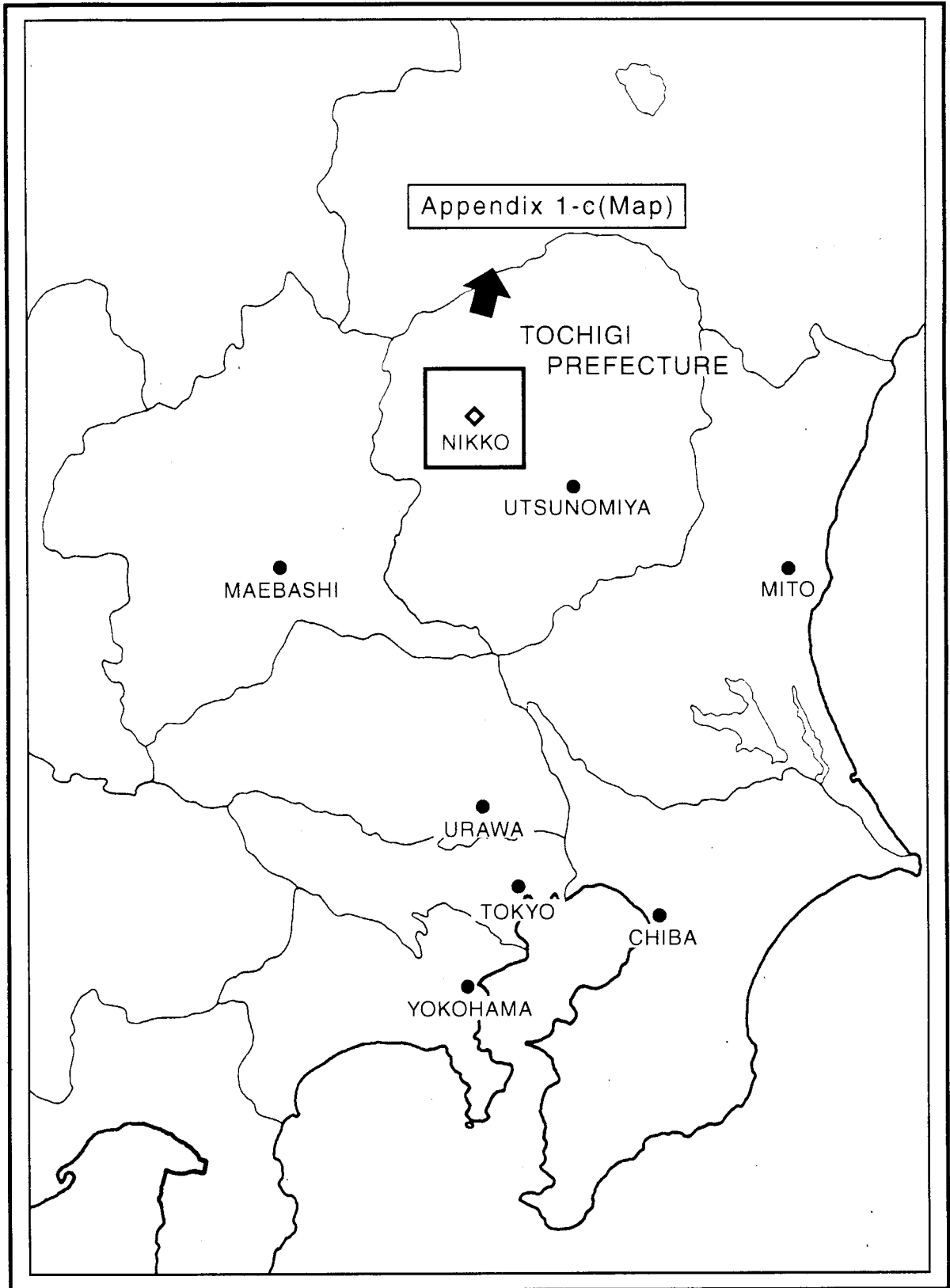

SCALE 1:1,500,000



**APPENDIX 1-c**

MAP INDICATING THE LOCATION OF THE NOMINATED PROPERTY

The Location in Nikko City

- Nikko City
- Nominated property 50.8ha
- Buffer zone\* 373.2ha
- (Total 424.0ha)
- \*not including the nominated property

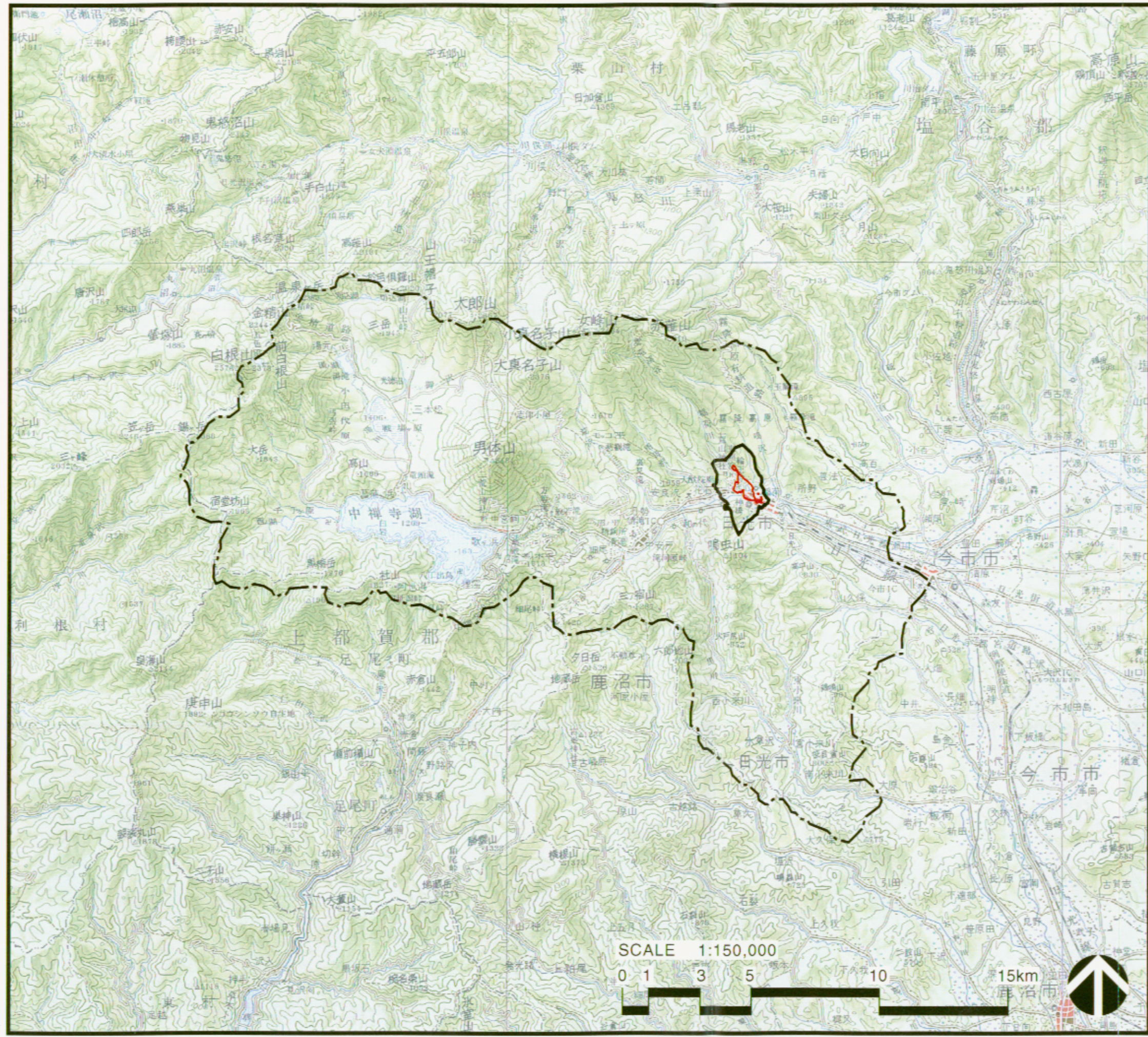

# APPENDIX 2-1

MAP INDICATING THE NOMINATED PROPERTY AND THE SURROUNDING NATURAL AND BUILT ENVIRONMENT

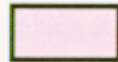
	Nominated property	50.8ha
	Buffer zone*	373.2ha
	(Total)	424.0ha)

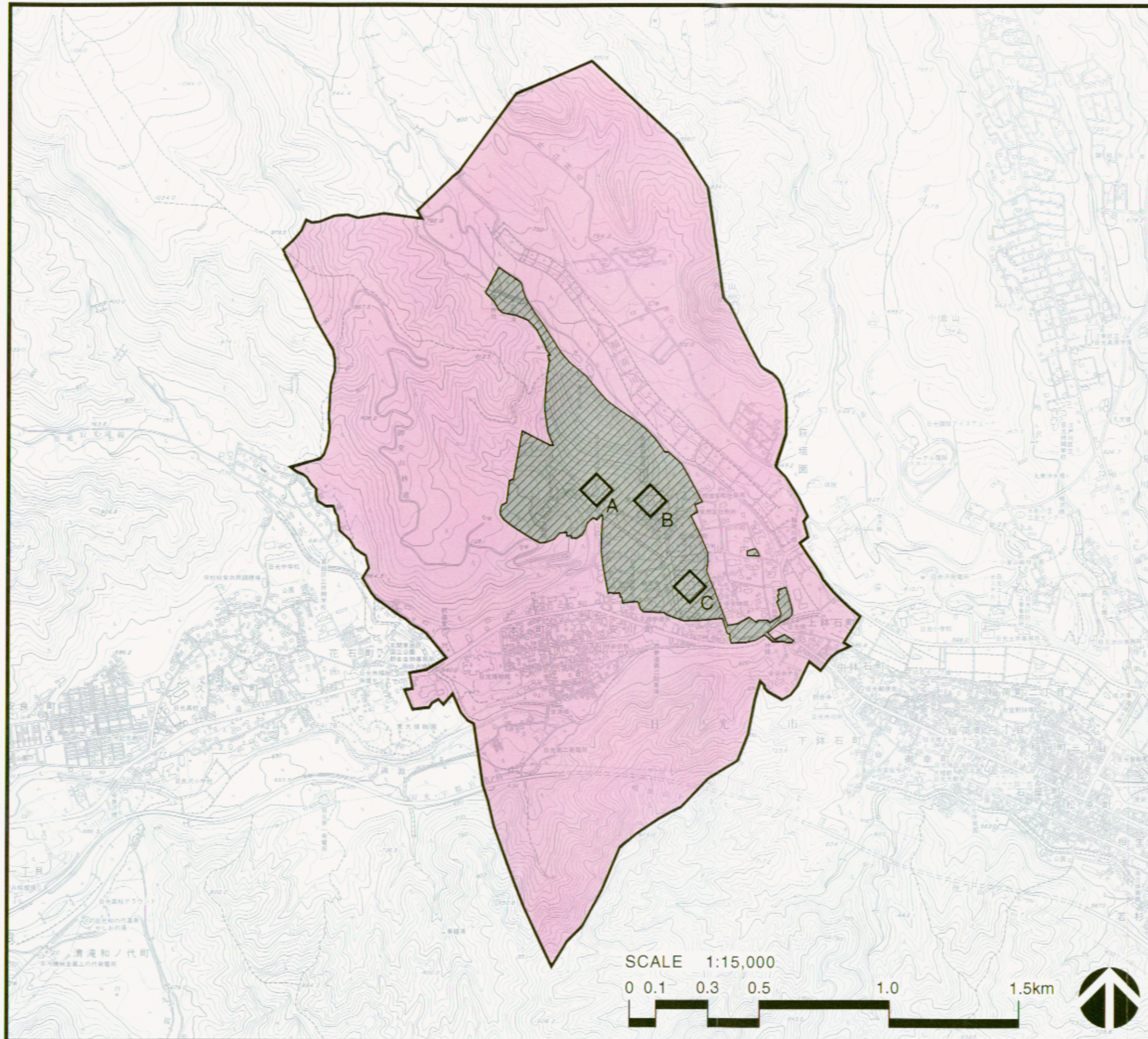

\*not including the nominated property

- 1 Group of buildings
-  A Futarasan-jinja
  -  B Tōshōgū
  -  C Rinnō-ji
- 2 Site (cultural landscape)
- 

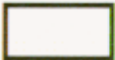

# APPENDIX 2-2

MAP INDICATING THE NOMINATED PROPERTY AND THE SURROUNDING NATURAL AND BUILT ENVIRONMENT

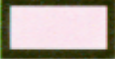
-  Nominated property
-  Nominated group of buildings
-  Buffer zone

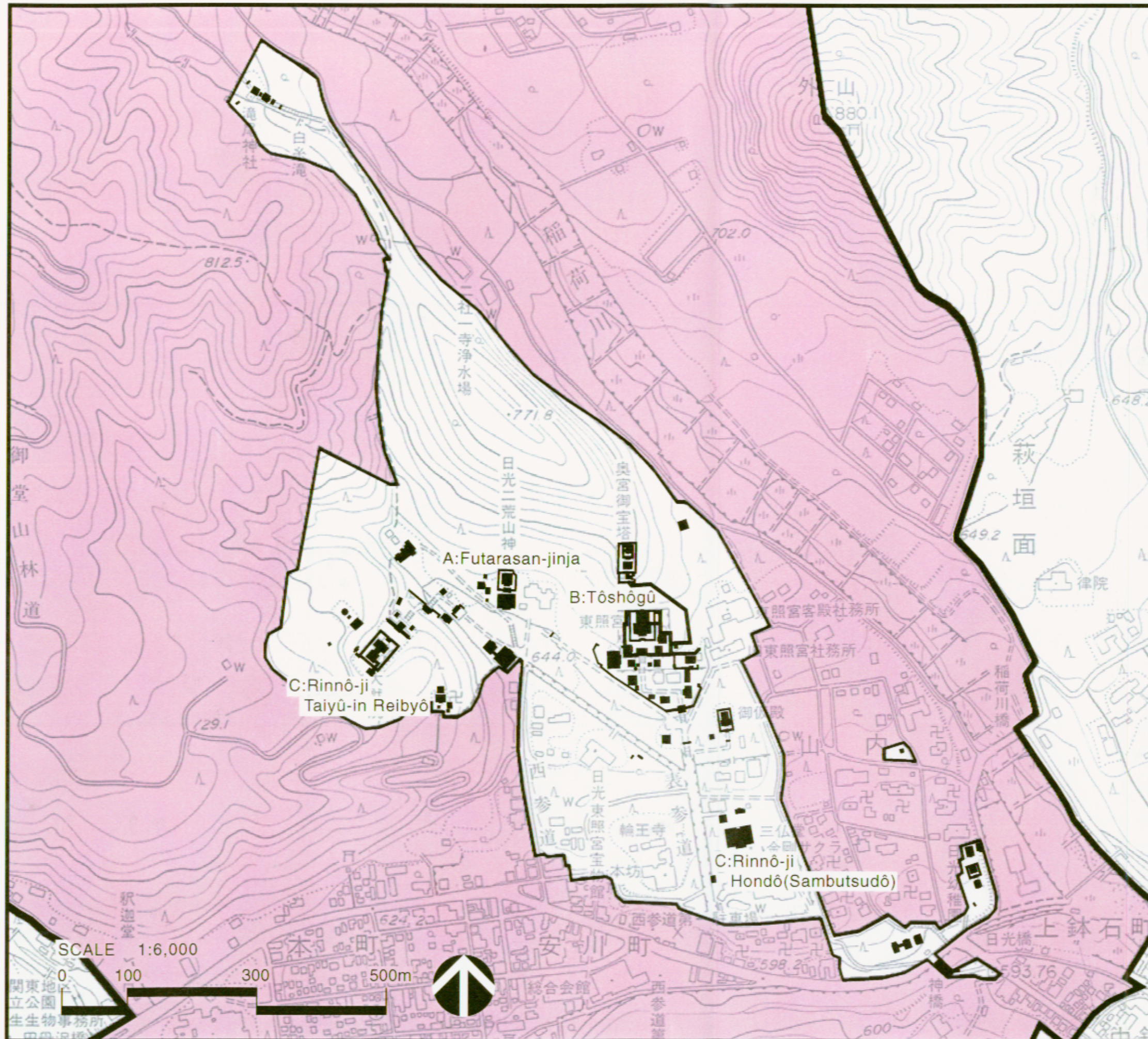

# APPENDIX 3

## MAP INDICATING THE EXTENT OF THE NOMINATED PROPERTY AND THE BUFFER ZONE

The Extent of the Nominated Property and the Buffer Zone with Indication of the Zones of Legal Protection

Designations under the Law for the Protection of Cultural Properties

 Historic Site

Designations under the Natural Parks Law

 Special Protection Area of National Park

 Class 2 Special Area of National Park

 Class 3 Special Area of National Park

 Ordinary Area of National Park

Designations under the City Planning Law

 Neighborhood Commercial District

 Commercial District

 Category 1 Residential District

 Scenic Zone

 Nominated property

 Buffer zone

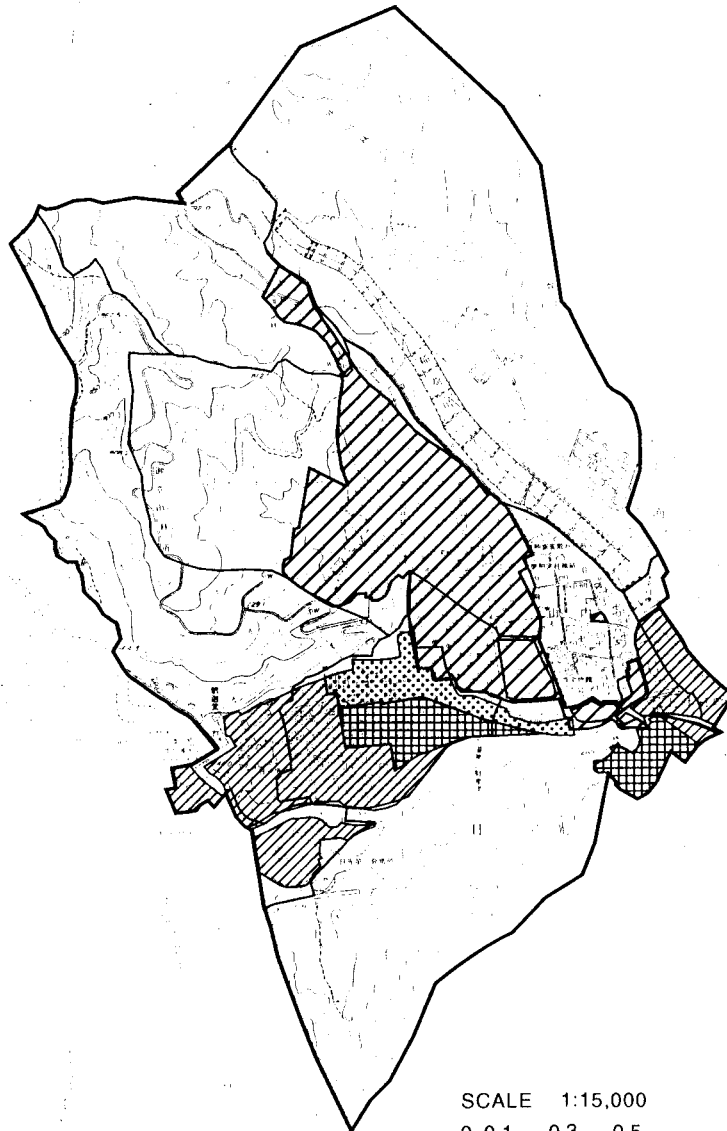

SCALE 1:15,000

0 0.1 0.3 0.5 1.0 1.5km



## APPENDIX 3-a-2

MAP INDICATING THE EXTENT OF  
THE NOMINATED PROPERTY AND  
THE BUFFER ZONE

The Extent of the Nominated Property  
and the Buffer Zone with Indication of  
the Zones of Legal Protection

Designations under the Forest Law

 Reserved Forest

Designations under the Sand Control Law

 Sand Control Area

Designations under the River Law

 River Area  
River Conservation Area

Designations under the Nikko Municipal  
Ordinance Concerning Townscape

 Townscape Formation Zone

 Nominated property

 Buffer zone

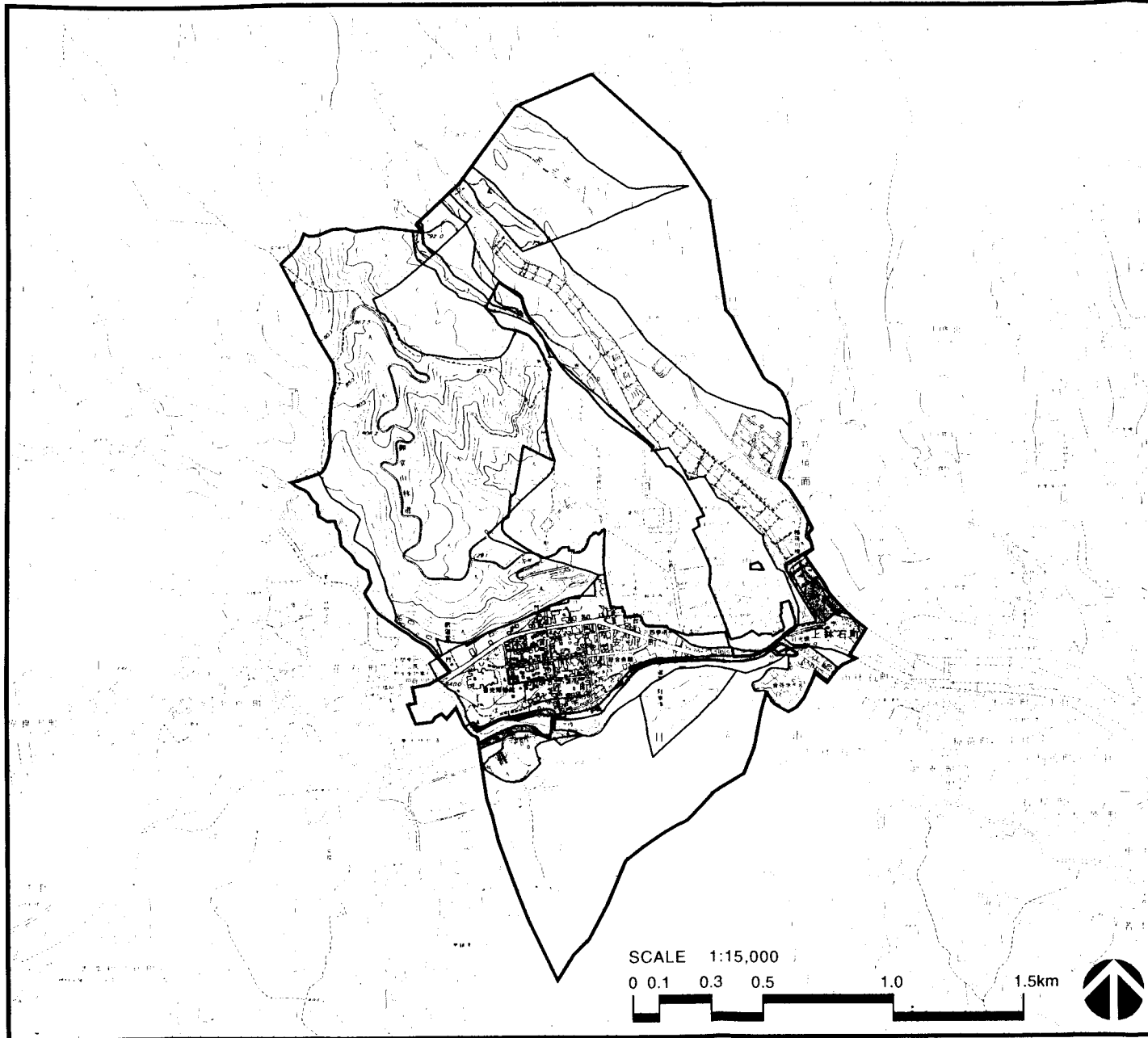





# APPENDIX 3-b-1'

MAP INDICATING THE EXTENT OF  
THE NOMINATED PROPERTY AND  
THE BUFFER ZONE

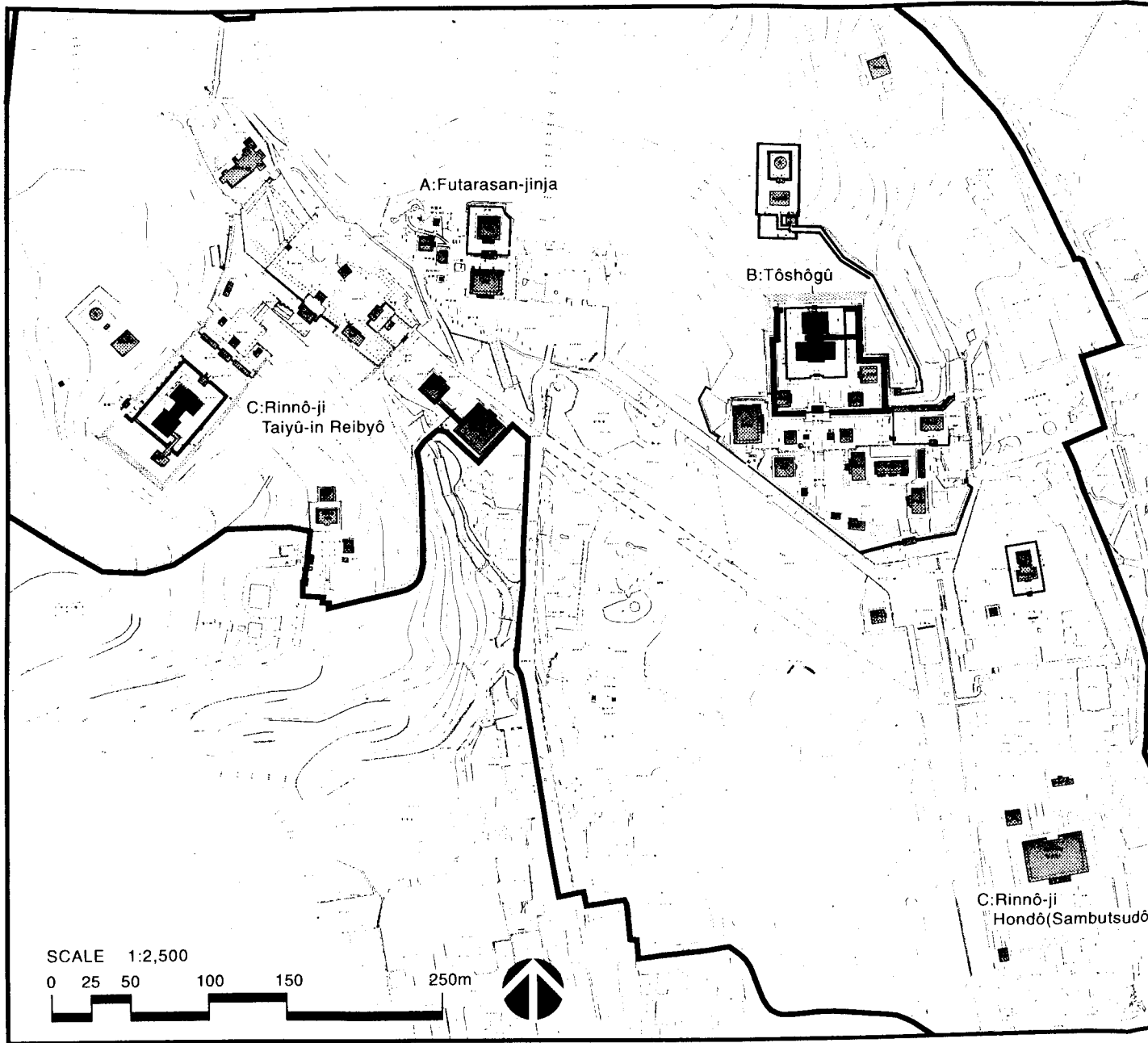
The Distribution of Main Buildings  
Included in the Nominated Property



-  National Treasure
-  Important Cultural Property

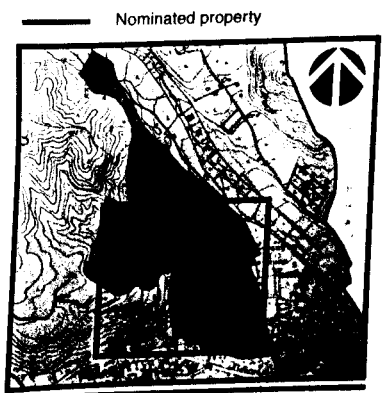

# APPENDIX 3-b-1

MAP INDICATING THE EXTENT OF THE NOMINATED PROPERTY AND THE BUFFER ZONE

The Distribution of Buildings Designated as National Treasures or Important Cultural Properties

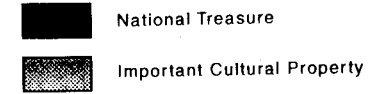

- [B22]Okusha Hôtô
- [B23]Okusha Karamon
- [B24]Okusha Ishitamagaki
- [B25]Okusha Haiden
- [B26]Okusha Dôjinko
- [B27]Okusha Torii
- [B28]Okusha Sekisaku

- [C4]Kaizandô
- [C5]Jôgyôdô
- [C6]Hokkedô
- [C7]Jôgyôdô Hokkedô Watarirô
- [C8]Jigendô Byôdô
- [C9]Jigendô Haiden
- [C10]Jigendô Kyôzô
- [C11]Jigendô Shôrô
- [C12]Jigendô Amidadô

- [A1]-[A5],[A16]-[A19] 3-b-3
- [B1]-[B21],[B29]-[B33],[B37]-[B38] 3-b-4
- [C17]-[C37] 3-b-5

— Nominated property

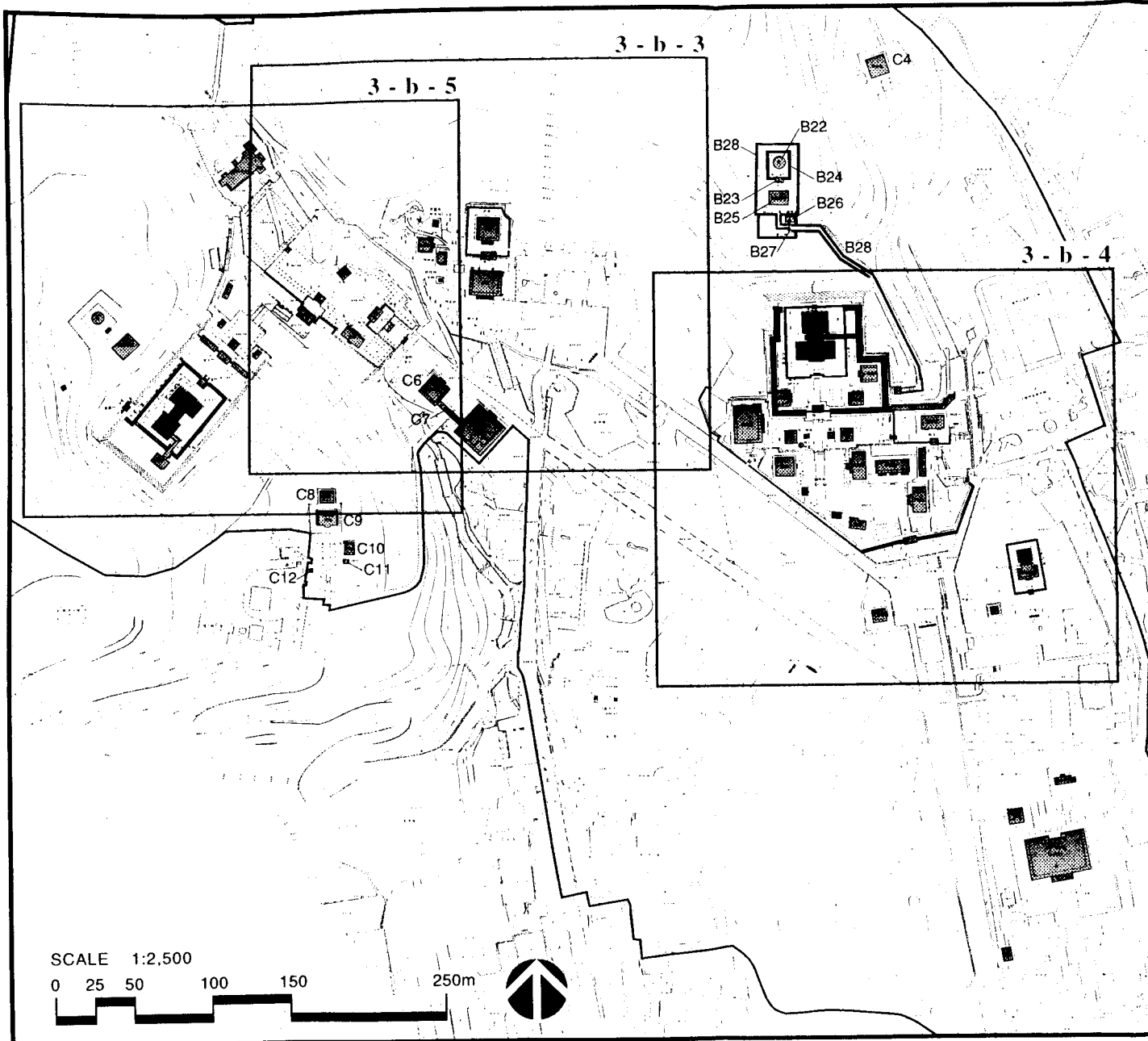
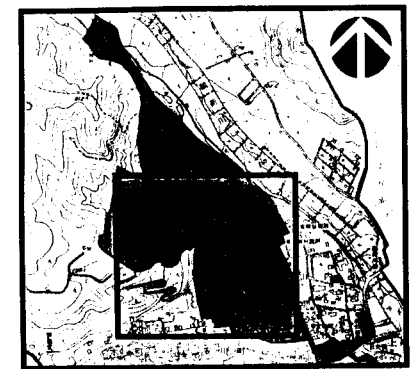

## APPENDIX 3-b-2

MAPS INDICATING THE EXTENT OF THE NOMINATED PROPERTY AND THE BUFFER ZONE

The Distribution of Buildings Designated as National Treasures or Important Cultural Properties

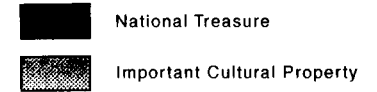

- [A6]Shinkyô
- [A7]Betsugû Takino-o-jinja Honden
- [A8]Betsugû Takino-o-jinja Karamon
- [A9]Betsugû Takino-o-jinja Haiden
- [A10]Betsugû Takino-o-jinja Rômon
- [A11]Betsugû Takino-o-jinja Torii
- [A12]Betsugû Hongû-jinja Honden
- [A13]Betsugû Hongû-jinja Karamon
- [A13]Betsugû Hongû-jinja Sukibê
- [A14]Betsugû Hongû-jinja Haiden
- [A15]Betsugû Hongû-jinja Torii

- [B34]Otabisho Honden
- [B35]Otabisho Haiden
- [B36]Otabisho Shinsenjo
- [B36-(1)]Watarirô

- [C1]Hondô (Sambutsudô)
- [C2]Sôrintô
- [C3]Hombô Omotemon
- [C13]Kodamadô
- [C14]Gohôtendô
- [C15]Kannondô
- [C16]Sanjûnotô

— Nominated property



JAPAN / NIKKO

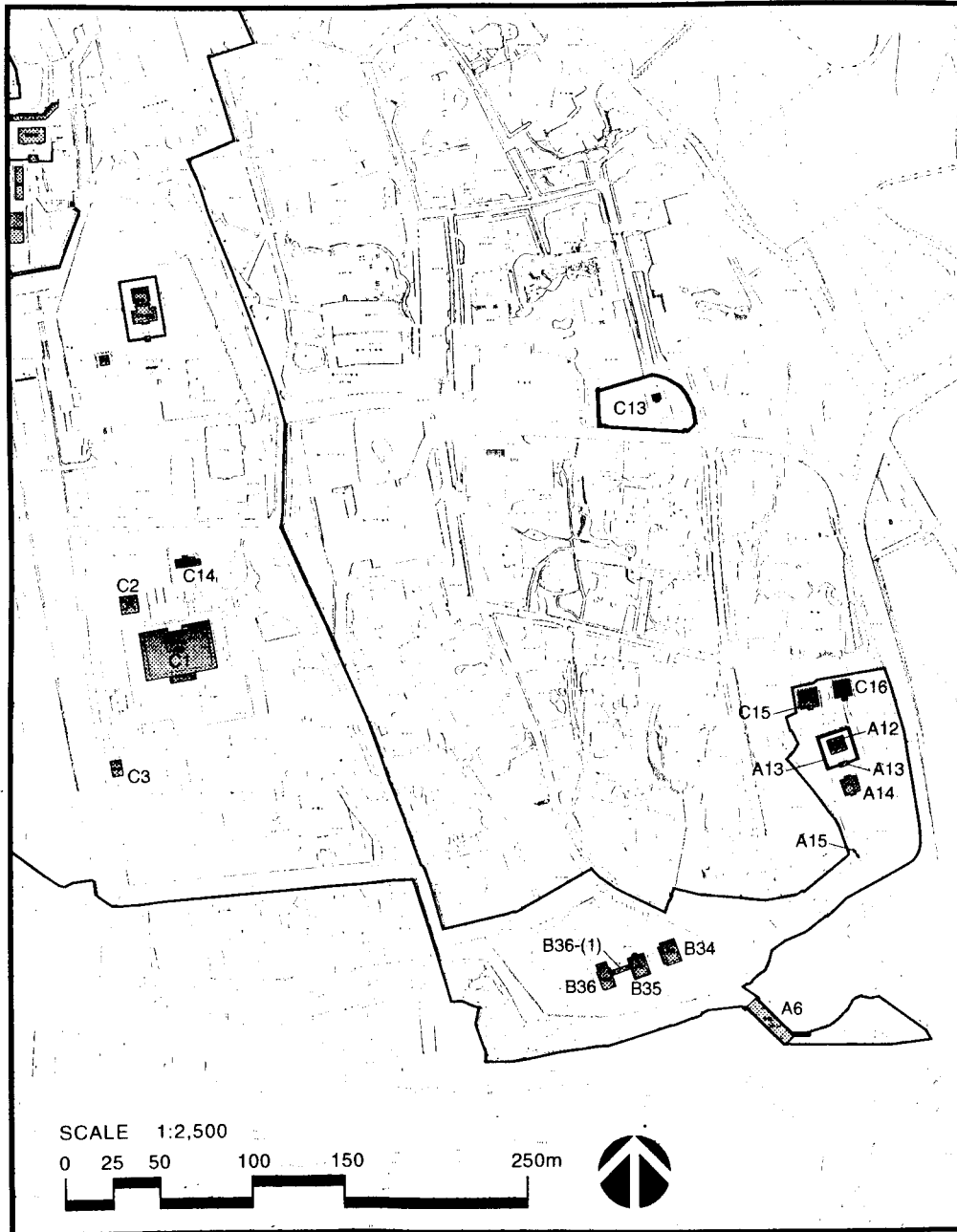

3 - b - 2 - 1

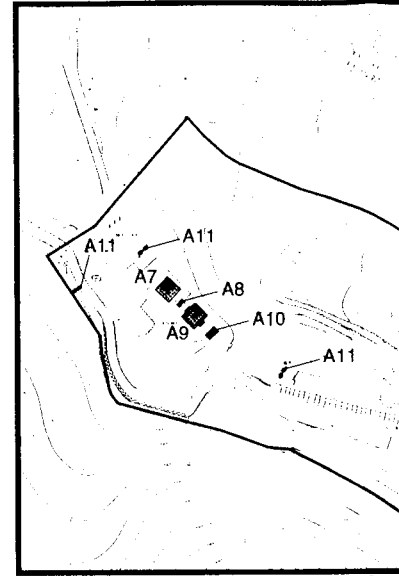



3 - b - 2 - 2

# APPENDIX 3-b-3

MAP INDICATING THE EXTENT OF THE NOMINATED PROPERTY AND THE BUFFER ZONE

The Distribution of Buildings Designated as National Treasures or Important Cultural Properties

A:Futarasan-jinja

-  National Treasure
-  Important Cultural Property

- [A1]Honden
- [A2]Karamon
- [A3]Wakimon
- [A3]Sukibê
- [A4]Haiden
- [A5]Torii
- [A16]Shin-yosha
- [A17]Daikokuden
- [A18]Massha Mitomo-jinja Honden
- [A19]Massha Hie-jinja Honden

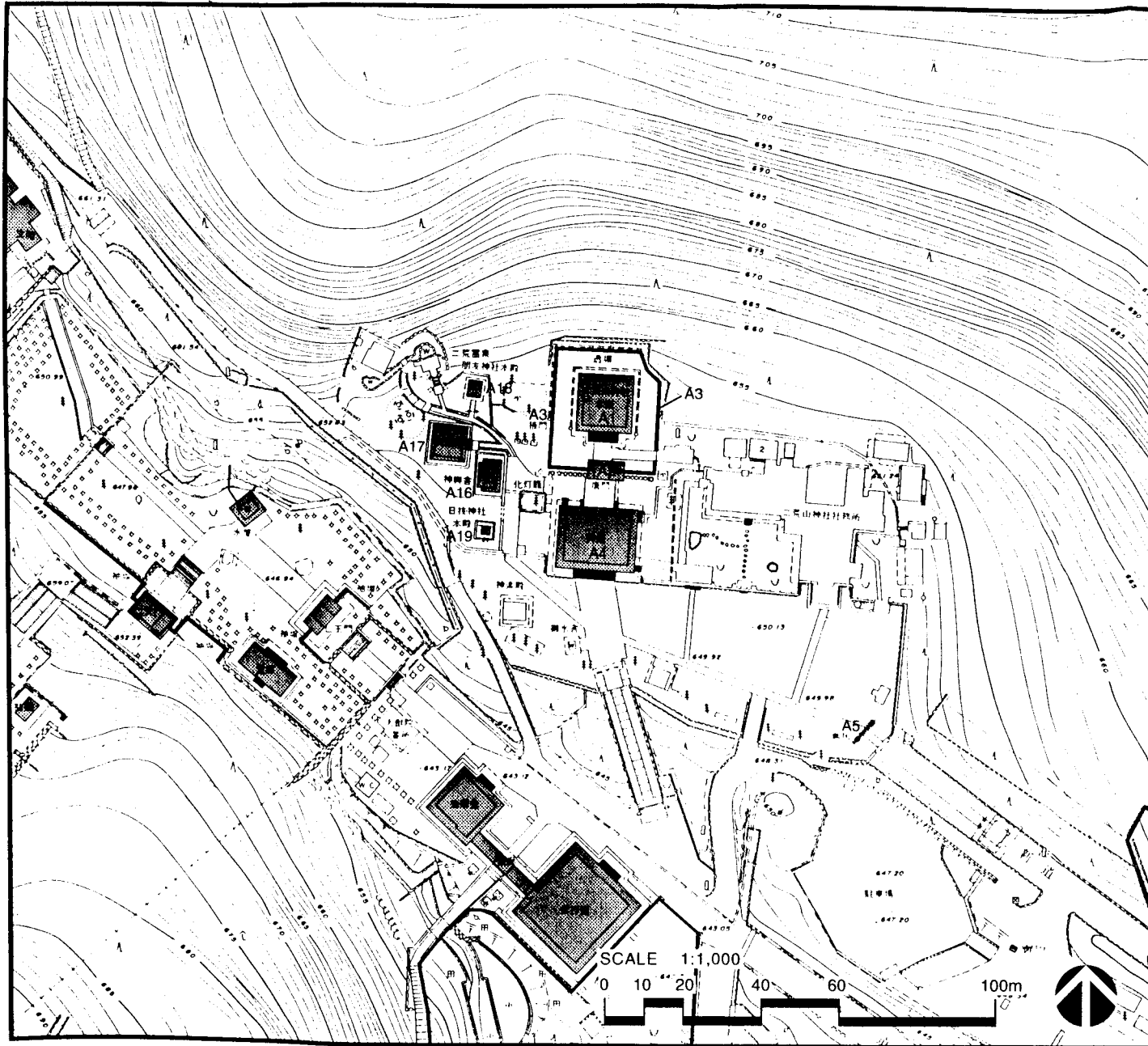

— Nominated property

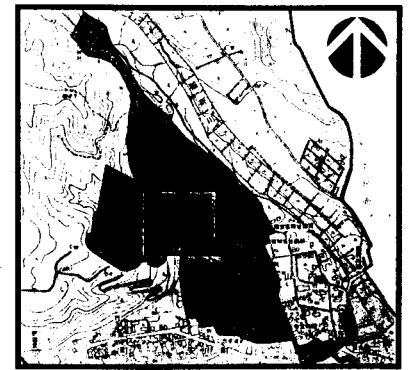



# APPENDIX 3-b-4

MAP INDICATING THE EXTENT OF THE NOMINATED PROPERTY AND THE BUFFER ZONE

The Distribution of Buildings Designated as National Treasures or Important Cultural Properties

B:Tôshôgû

-  National Treasure
-  Important Cultural Property

[B1]Honden	[B20]Ishidorii
[B1]Ishinoma	[B20-(1)]Shôsha
[B1]Haiden	[B20-(2)]Tôdaihoiya
[B2]Shômen Karamon	[B20-(3)]Tôdaihoiya
[B2]Haimen Karamon	[B20-(4)]Dôjinko
[B3]Tôzai Sukibé	[B20-(5)]Watarirô
[B4]Yômeimon	[B20-(6)]Dôkomon and Itabé
[B5]Tôzai Kairô	[B20-(7)]Hijûmon and Dôttabé
[B5-(1)]Kugurimon	[B20-(8)]Uchibansho
[B6]Kamishamusho	[B20-(9)]Saijô
[B7]Kaguraden	[B20-(10)]Higashitsûyôgomon (Shakemon)
[B8]Shin-yosha	[B21]Sakashitamon
[B9]Shôrô	[B29]Kariden Honden
[B10]Korô	[B29]Kariden Ainoma
[B11]Honjîdô*	[B29]Kariden Haiden
[B12]Kyûzô*	[B30]Kariden Karamon
[B13]Kamijinko	[B31]Kariden Wakimon
[B14]Nakajinko	[B31]Kariden Sukibé
[B15]Shimojinko	[B32]Kariden Torii
[B16]Mizuya	[B33]Kariden Shôrô
[B17]Shinkyû	[B37]Kyûokusha Karamon
[B18]Omotemon	[B38]Kyûokusha Torii
[B18-(1)]Sasarakobé	
[B19]Gojûnotô	

\* indicates that the building is in the custody of the Foundation for the Preservation of Shrines and Temples of Nikko.

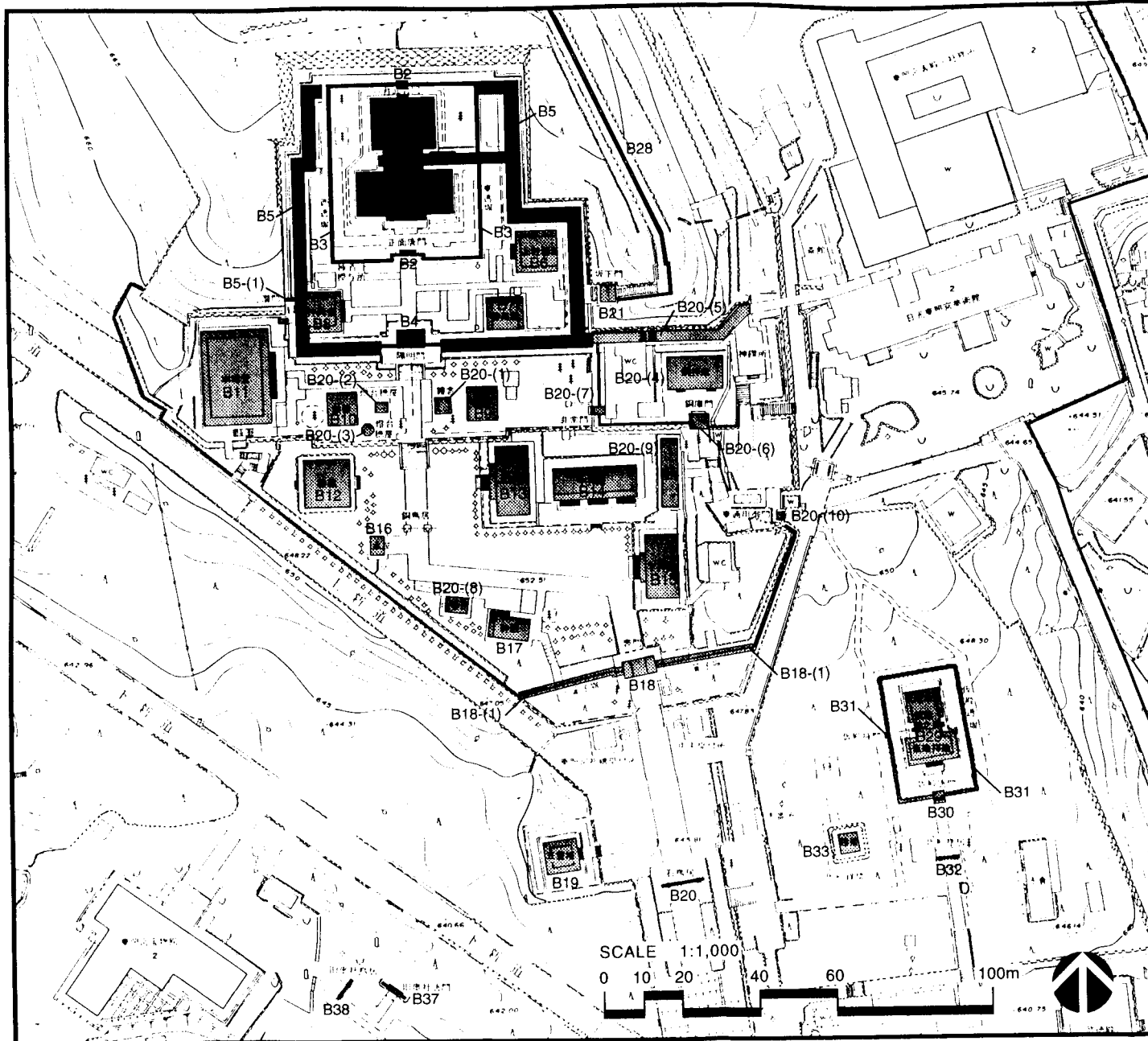
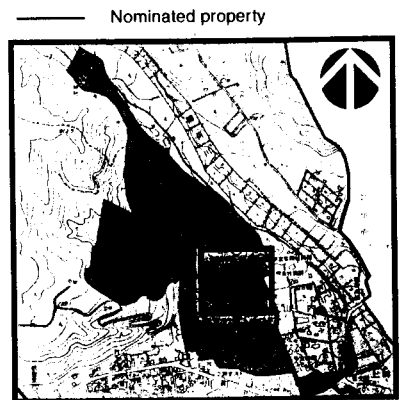



# APPENDIX 3-b-5

MAP INDICATING THE EXTENT OF THE NOMINATED PROPERTY AND THE BUFFER ZONE

The Distribution of Buildings Designated as National Treasures or Important Cultural Properties

C:Rinnō-ji

-  National Treasure
-  Important Cultural Property

- [C17]Taiyū-in Reibyō Honden
- [C17-(1)]Zushi
- [C17]Taiyū-in Reibyō Ainoma
- [C17]Taiyū-in Reibyō Haiden
- [C18]Taiyū-in Reibyō Karamon
- [C19]Taiyū-in Reibyō Mizugaki
- [C20]Taiyū-in Reibyō Wakimon
- [C21]Taiyū-in Reibyō Gokūsho
- [C22]Taiyū-in Reibyō Gokūsho Watarirō
- [C23]Taiyū-in Reibyō Yashamon
- [C24]Taiyū-in Reibyō Yashamon Sayū Kairō
- [C24-(1)]Kugurimon
- [C25]Taiyū-in Reibyō Shōrō
- [C26]Taiyū-in Reibyō Korō
- [C27]Taiyū-in Reibyō Nitemmon
- [C27-(1)]Sayū Sodebē
- [C28]Taiyū-in Reibyō Saijō
- [C29]Taiyū-in Reibyō Mizuya
- [C30]Taiyū-in Reibyō Hōko
- [C31]Taiyū-in Reibyō Niōmon
- [C31-(1)]Sayū Sodebē
- [C32]Taiyū-in Reibyō Kōkamon
- [C32-(1)]Sayū Sodebē
- [C33]Taiyū-in Reibyō Dōzutsumi Hōzō
- [C34]Taiyū-in Reibyō Oku-in Hōtō
- [C35]Taiyū-in Reibyō Oku-in Inukimon
- [C36]Taiyū-in Reibyō Oku-in Haiden
- [C37]Taiyū-in Reibyō Bettōsho Ryūkō-in
- [C37-(1)]Genkan

 Nominated property

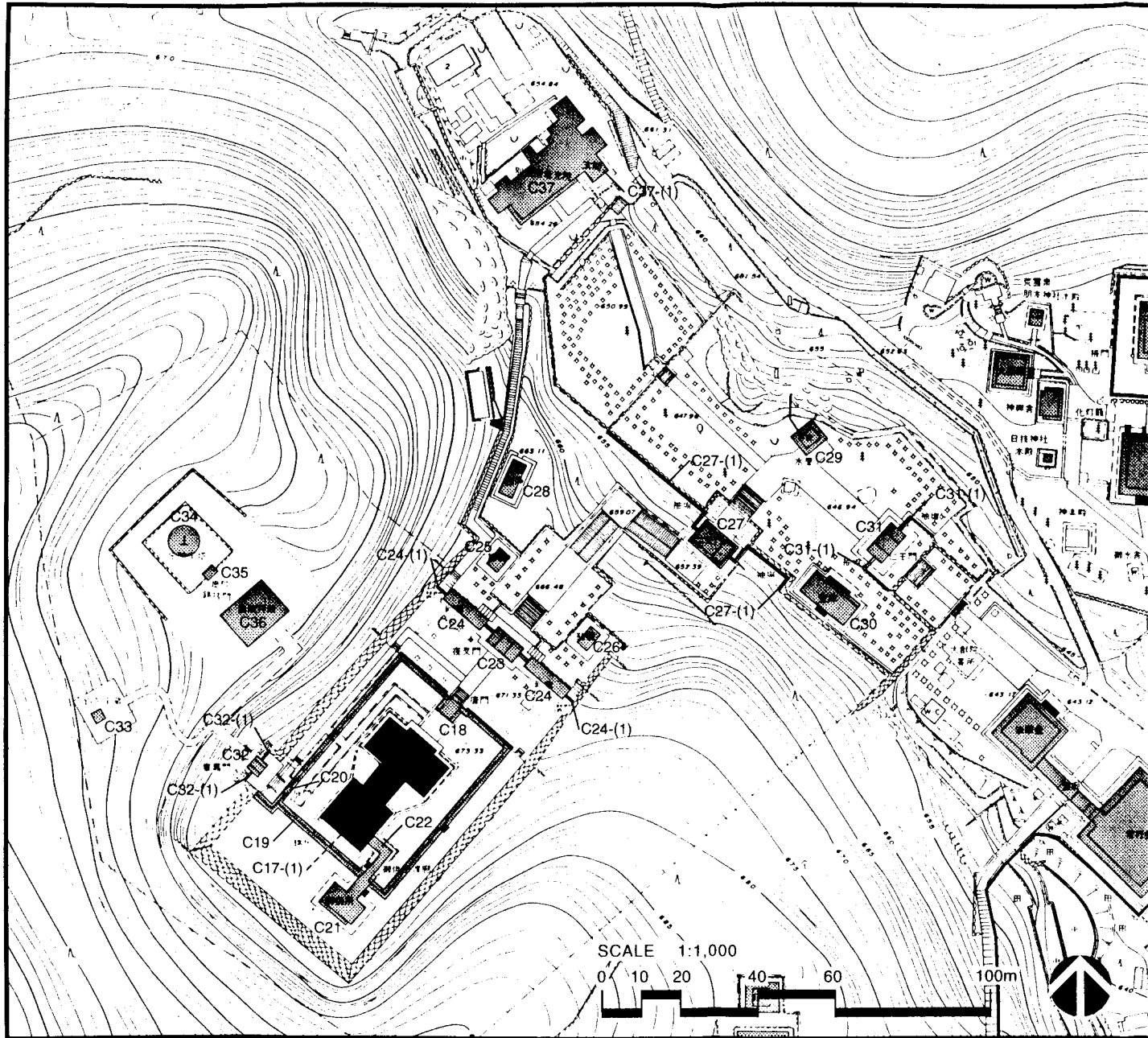
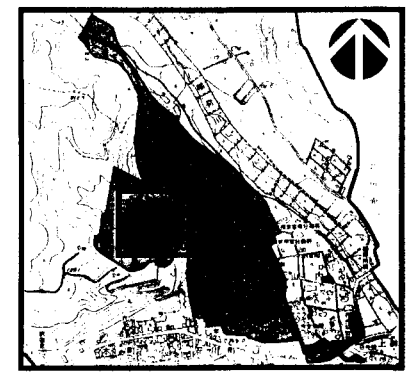

# APPENDIX 4-a-1

## INVENTORY OF THE CULTURAL ASSETS; COPIES OF THE OFFICIAL DESIGNATION NOTICES

Inventory of the Buildings (National Treasures and Important Cultural Properties) Included in the Nominated Property

A:Futarasan-jinja

No.	Name of the building designated as a National Treasure or an Important Cultural Property	Number of buildings	Date of designation	Year of construction	Description	
A 1	Honden	*	1	1908.08.01	1619	Shrine building enshrining the three deities of Futarasan-jinja, i.e. Ōnamuchi no Mikoto, Tagorihime no Mikoto and Ajsukitakahikone no Mikoto.
A 2	Karamon	*	1	1944.09.05	early Edo Period	Gate in front of the Honden.
A 3	Wakimon and Sukibé	*	2	1944.09.05	early Edo Period	
	Wakimon					Gate of the Sukibé.
	Sukibé					Roofed wall with latticed windows which encloses the Honden.
A 4	Haiden	*	1	1908.08.01	1645	Building for worshipping the deities of Futarasan-jinja.
A 5	Torii	*	1	1944.09.05	1799	Copper torii at the front approach to Futarasan-jinja, marking the entry into the sacred area.
A 6	Shinkyō	*	1	1944.09.05	1904	Wooden arched bridge located at the entrance to the sacred area known as the Nikko Sannai area.
A 7	Betsugū Takino-o-jinja Honden	*	1	1944.09.05	1713	Shrine building where Tagorihime no Mikoto, a deity of Futarasan-jinja, is enshrined.
A 8	Betsugū Takino-o-jinja Karamon	*	1	1944.09.05	1740	Gate in front of the Betsugū Takino-o-jinja Honden.
A 9	Betsugū Takino-o-jinja Haiden	*	1	1944.09.05	circa 1713	Building for worshipping the deity.
A 10	Betsugū Takino-o-jinja Rōmon	*	1	1944.09.05	1697	Gate to the Betsugū Takino-o-jinja.
A 11	Betsugū Takino-o-jinja Torii	*	3	1944.09.05	1696,1779	Stone torii at the front approach to the Betsugū Takino-o-jinja, marking the entry into the sacred area.
A 12	Betsugū Hongū-jinja Honden	*	1	1944.09.05	1685	Shrine building where Ajsukitakahikone no Mikoto, a deity of Futarasan-jinja, is enshrined.
A 13	Betsugū Hongū-jinja Karamon and Sukibé	*	2	1944.09.05	circa 1685	
	Karamon					Gate in front of the Betsugū Hongū-jinja Honden.
	Sukibé					Wooden roofed wall which encloses the Betsugū Hongū-jinja Honden.
A 14	Betsugū Hongū-jinja Haiden	*	1	1973.06.02	1685	Building for worshipping the deity.
A 15	Betsugū Hongū-jinja Torii	*	1	1973.06.02	1800	Stone torii at the front approach to the Betsugū Hongū-jinja, marking the entry into the sacred area.
A 16	Shin-yōsha	*	1	1973.06.02	1641	Storehouse for portable shrines.
A 17	Daikokuden	*	1	1973.06.02	1745	Shrine building where Ōkuninushi no Mikoto is enshrined.
A 18	Massha Mitomo-jinja Honden	*	1	1973.06.02	circa 1751 ~ 1761	Shrine building where Sukunabikona no Mikoto is enshrined.
A 19	Massha Hie-jinja Honden	*	1	1973.06.02	circa 1648 ~ 1651	Shrine building where Ōyamakui no Mikoto is enshrined.
	Subtotal		23			

## APPENDIX 4-a-2

### INVENTORY OF THE CULTURAL ASSETS; COPIES OF THE OFFICIAL DESIGNATION NOTICES

Inventory of the Buildings (National  
Treasures and Important Cultural  
Properties) Included in the Nominated  
Property

B:Tôshôgû

No.	Name of the building designated as a National Treasure or an Important Cultural Property	Number of buildings	Date of designation	Year of construction	Description
B 1	Honden, Ishinoma and Haiden	**	1951.06.09	1636	
	Honden				Shrine building where Tôshô Daigongen, or the deified image of Tokugawa Ieyasu, is enshrined.
	Ishinoma				Stone-floored chamber connecting the Honden and the Haiden.
	Haiden				Building for worshipping the deity.
B 2	Shômen and Haimen Karamon	**	1951.06.09	1636	
	Shômen Karamon				Gate in front of the Haiden. A third gate.
	Haimen Karamon				Gate at the back of the Honden.
B 3	Tôzai Sukibê	**	1951.06.09	1636	Roofed walls with openwork and latticed windows which enclose the Honden, Ishinoma and Haiden.
B 4	Yômeimon	**	1951.06.09	1636	A second gate of Tôshôgû. Magnificently decorated two-storied structure representing the typical characteristics of Tôshôgû.
B 5	Tôzai Kairô	**	1951.06.09	1636	Roofed cloisters which enclose shrine buildings including the Honden.
	B 5-(1) Kugurimon			1636	
B 6	Kamishamusho	*	1908.08.01	1636	Building where Shintoist religious service is conducted.
B 7	Kaguraden	*	1908.08.01	early Edo Period	Building where the Shintoist ritual called Kagura is performed.
B 8	Shin-yosha	*	1908.08.01	1636	Storehouse for portable shrines.
B 9	Shôrô	*	1908.08.01	1636	Bell house.
B10	Korô	*	1908.08.01	1636	Storehouse for the drums.
B11	Honjîdô*	*	1908.08.01	1636	Building where a statue of Yakushi, the healing Buddha, is enshrined.
B12	Kyôzô*	*	1908.08.01	1636	Storehouse for sutras.
B13	Kamijinko	*	1908.08.01	early Edo Period	Storehouse of the <i>Azokura-zukuri</i> ("log-house" repository style) for religious habits worn in the Togoyasu festival, also known as the Hyakumonzorori Sennin Gyôretsû.
B14	Nakajinko	*	1908.08.01	early Edo Period	
B15	Shimojinko	*	1908.08.01	early Edo Period	
B16	Mizuya	*	1908.08.01	1636	Stone building sheltering the water basin to which water is supplied by a mechanism of siphon.
B17	Shinkyû	*	1908.08.01	1636	Stable for sacred horses.
B18	Omotemon	*	1908.08.01	1636	The first gate of Tôshôgû, located at the entrance to the shrine.
	B18-(1) Sasarakobê			1636	
B19	Gojûnotô	*	1908.08.01	1818	Five-storied pagoda where a statue of Dainichi Nyorai (Mahavairocana Buddha) is enshrined.
B20	Ishidorii	*	1908.08.01	1618	Large-scale stone torii at the front approach.
	B20-(1) Shôsha		1908.08.01	1644 ~ 1648	Copper-plated bell house.
	B20-(2) Tôdaihoya		1908.08.01	1644 ~ 1648	Copper-plated building sheltering a revolving lantern.
	B20-(3) Tôdaihoya		1908.08.01	1636	Copper-plated octagonal building to support a hanging lantern.
	B20-(4) Dôjinko		1908.08.01	1636	Copper-plated fireproof treasury.
	B20-(5) Watarirô		1908.08.01	early Edo Period	Roofed corridor between the eastern part of the Tôzai Kairô and the Kamishamusho.



## APPENDIX 4-a-3

### INVENTORY OF THE CULTURAL ASSETS; COPIES OF THE OFFICIAL DESIGNATION NOTICES

Inventory of the Buildings (National Treasures and Important Cultural Properties) Included in the Nominated Property

B:Tōshōgū

No.	Name of the building designated as a National Treasure or an Important Cultural Property	Number of buildings	Date of designation	Year of construction	Description
B20-(6)	Dōkomon and Itabē		1908.08.01	circa 1804 ~ 1817	Gate in front of the Dōjinko and roofed walls on both sides of it.
B20-(7)	Hijōmon and Dōitabē		1908.08.01	1689	Gate in the west of the Dōjinko and copper-plated firewalls.
B20-(8)	Uchibansho		1908.08.01	circa 1789 ~ 1800	Building where security guards are stationed.
B20-(9)	Saijō		1908.08.01	circa 1624 ~ 1643	Lavatory for religious use on the occasion of ritual.
B20-(10)	Higashitsūyōgomon(Shakemon)		1908.08.01	early Edo Period	Gate on the east of the compounds of Tōshōgū for the use of hereditary Shinto priests and their family members.
B21	Sakashitamon	*	1908.08.01	1636	Gate at the entrance of the front approach to the Okusha where the remains of Tokugawa Ieyasu are enshrined.
B22	Okusha Hōtō	*	1908.08.01	1683	Building where the remains of Tokugawa Ieyasu are enshrined.
B23	Okusha Karamon	*	1908.08.01	1650	Gate in front of the Okusha Hōtō.
B24	Okusha Ishitamagaki	*	1944.09.05	early Edo Period	Stonewall enclosing the Okusha.
B25	Okusha Haiden	*	1908.08.01	1636	Building for worshiping the deity enshrined in the Okusha.
B26	Okusha Dōjinko	*	1944.09.05	1654	Copper-plated storehouse for treasure of the Okusha.
B27	Okusha Torii	*	1944.09.05	circa 1683	Copper torii at the front approach to the Okusha.
B28	Okusha Sekisaku	*	1944.09.05	early Edo Period	Stone fence along the front approach to the Okusha.
B29	Kariden Honden, Ainoma and Haiden	*	1944.09.05	1639	
	Kariden Honden				Shrine building where the deity of Tōshōgū is tentatively enshrined on the occasion of repair work on the Honden.
	Kariden Ainoma				Building connecting the Kariden Honden and the Kariden Haiden.
	Kariden Haiden				Building used tentatively for worshiping the deity of Tōshōgū on the occasion of repair work on the Honden.
B30	Kariden Karamon	*	1944.09.05	early Edo Period	Gate in front of the Kariden Honden.
B31	Kariden Wakimon and Sukibē	*	1944.09.05	early Edo Period	
	Kariden Wakimon				Gate of the Kariden Sukibē.
	Kariden Sukibē				Roofed wall with diamond-shaped-latticed windows which encloses the Kariden Honden.
B32	Kariden Torii	*	1944.09.05	early Edo Period	Copper torii at the front approach to the Kariden Honden.
B33	Kariden Shōrō	*	1944.09.05	early Edo Period	Bell house.
B34	Otabisho Honden	*	1944.09.05	1685	Building where the portable shrine enshrining the deity of Tōshōgū is carried into in the Togyosai festival.
B35	Otabisho Haiden	*	1944.09.05	circa 1685	Building for worshiping the deity of Tōshōgū on the occasion of the Togyosai festival.
B36	Otabisho Shinsenjo	*	1944.09.05	circa 1685	Building where sacred food is prepared on the occasion of the Togyosai festival.
B36-(1)	Watarirō		1908.08.01	circa 1685	Gate on the east of the compounds of Tōshōgū for the use of hereditary Shinto priests and their family members.
B37	Kyūokusha Karamon	*	1973.06.02	1641	Chinese-style stone gate of the Kyūokusha, reconstructed in a new location (the present location) after demolished in an earthquake.
B38	Kyūokusha Torii	*	1973.06.02	1641	Torii of the Kyūokusha, reconstructed in a new location after demolished in an earthquake.
	Subtotal	42			

# APPENDIX 4 - a - 4

## INVENTORY OF THE CULTURAL ASSETS; COPIES OF THE OFFICIAL DESIGNATION NOTICES

Inventory of the Buildings (National Treasures and Important Cultural Properties) Included in the Nominated Property

C:Rinnō-ji

No.	Name of the building designated as a National Treasure or an Important Cultural Property	Number of buildings	Date of designation	Year of construction	Description	
C 1	Hondō(Sambutsudō)	*	1	1917.04.05	1647	Buddha hall where statues of Amida Nyorai (Amitabha Buddha), Senju Kannon (a bodhisattva with 1,000 arms) and Batō Kannon (Avalokiteshvara with a fierce face and a horse's head in the hairdress) are enshrined.
C 2	Sōrintō	*	1	1917.08.13	1643	Copper repository for sutras.
C 3	Hombō Omotemon	*	1	1944.09.05	mid Edo Period	Front gate of the Hombō of Rinnō-ji.
C 4	Kaizandō	*	1	1944.09.05	circa 1720	Founder's hall dedicated to Buddhist priest Shōdō, the founder of Rinnō-ji, where a statue of Jizō Bosatsu (Bodhisattva Ksitigarbha) is enshrined.
C 5	Jōgyōdō	*	1	1944.09.05	1649	Buddha hall where a statue of Amida Nyorai (Amitabha Buddha) is enshrined.
C 6	Hokkedō	*	1	1944.09.05	1649	Buddha hall where a statue of Shaka Nyorai (Shakyamuni Buddha) is enshrined.
C 7	Jōgyōdō Hokkedō Watarirō	*	1	1944.09.05	1649	Roofed corridor between the Jōgyōdō and the Hokkedō.
C 8	Jigendō Byōdō	*	1	1944.09.05	early Edo Period	Building where the remains of Buddhist priest Tenka, the executor of Tokugawa Ieyasu's will, are enshrined.
C 9	Jigendō Haiden	*	1	1944.09.05	1649	Building for worshipping the deity of the Jigendō.
C10	Jigendō Kyōzō	*	1	1944.09.05	early Edo Period	Storehouse for documents collected by Buddhist priest Tenka.
C11	Jigendō Shōrō	*	1	1944.09.05	early Edo Period	Bell house.
C12	Jigendō Amidadō	*	1	1944.09.05	1646	Buddha hall where a statue of Amida Nyorai (Amitabha Buddha) is enshrined.
C13	Kodamadō	*	1	1944.09.05	early Edo Period	Buddha hall where Kodama is enshrined.
C14	Gohōtendō	*	1	1973.06.02	circa 1615 ~ 1623	Buddha hall where Bishamonten (Vajravana), Benzaiten (Sarasvati) and Daikokuten are enshrined.
C15	Kannondō	*	1	1973.06.02	1685	Buddha hall where a statue of Kanzenon Bosatsu (Avalokiteshvara Ksitigarbha) is enshrined.
C16	Sanjūnotō	*	1	1973.06.02	1685	Three-storied pagoda.
C17	Taiyū-in Reibyō Honden, Ainoma and Haiden	**	1	1952.11.22	1653	
	Taiyū-in Reibyō Honden					Building where Taiyū-in, or the deified image of Tokugawa Iemitsu, is enshrined.
C17-(1)	Zushi				1653	
	Taiyū-in Reibyō Ainoma					Chamber connecting the Taiyū-in Reibyō Honden and the Taiyū-in Reibyō Haiden.
	Taiyū-in Reibyō Haiden					Building for worshipping the deity.
C18	Taiyū-in Reibyō Karamon	*	1	1908.08.01	1653	Gate in front of the Taiyū-in Reibyō.
C19	Taiyū-in Reibyō Mizugaki	*	1	1908.08.01	1653	Roofed wall with openwork and latticed windows which encloses the Taiyū-in Reibyō Honden and other buildings.
C20	Taiyū-in Reibyō Wakimon	*	1	1944.09.05	1653	Gate of the Taiyū-in Reibyō Mizugaki.
C21	Taiyū-in Reibyō Gokūsho	*	1	1944.09.05	1653	Building where the sacred food is prepared as an offering to the deity.
C22	Taiyū-in Reibyō Gokūsho Watarirō	*	1	1944.09.05	1653	Roofed corridor between the Taiyū-in Reibyō Honden and the Taiyū-in Reibyō Gokūsho.
C23	Taiyū-in Reibyō Yashamon	*	1	1908.08.01	1653	A third gate of the Taiyū-in Reibyō.
C24	Taiyū-in Reibyō Yashamon Sayū Kairō	*	2	1908.08.01	1653	Roofed corridors on both sides of the Taiyū-in Reibyō Yashamon.
	C24-(1) Kugurimoh				1653	
C25	Taiyū-in Reibyō Shōrō	*	1	1908.08.01	1653	Bell house.

# APPENDIX 4-a-5

## INVENTORY OF THE CULTURAL ASSETS; COPIES OF THE OFFICIAL DESIGNATION NOTICES

Inventory of the Buildings (National Treasures and Important Cultural Properties) Included in the Nominated Property

C:Rinnō-ji

No.	Name of the building designated as a National Treasure or an Important Cultural Property	Number of buildings	Date of designation	Year of construction	Description
C26	Taiyū-in Reibyō Korō	*	1908.08.01	1653	Storehouse for the drums.
C27	Taiyū-in Reibyō Nitemmon	*	1908.08.01	1653	A second gate of the Taiyū-in Reibyō.
	C27-(1) Sayū Sodebē			1653	
C28	Taiyū-in Reibyō Saijō	*	1944.09.05	1653	Lavatory for religious use on the occasion of ritual.
C29	Taiyū-in Reibyō Mizuya	*	1908.08.01	1653	Stone-column building sheltering the water basin.
C30	Taiyū-in Reibyō Hōko	*	1908.08.01	1653	Storehouse of the <i>Azekura-zukuri</i> ("log-house" repository style).
C31	Taiyū-in Reibyō Niōmon	*	1908.08.01	1653	Gate at the entrance to the Taiyū-in Reibyō. The first gate.
	C31-(1) Sayū Sodebē			1653	
C32	Taiyū-in Reibyō Kōkamon	*	1908.08.01	1653	Gate at the entrance to the Taiyū-in Reibyō Oku-in.
	C32-(1) Sayū Sodebē			1653	
C33	Taiyū-in Reibyō Dōzutsumi Hōzō	*	1944.09.05	1653	Copper-plated storehouse of the <i>Azekura-zukuri</i> ("log-house" repository style).
C34	Taiyū-in Reibyō Oku-in Hōtō	*	1908.08.01	1683	Building where the remains of Tokugawa Iemitsu are enshrined.
C35	Taiyū-in Reibyō Oku-in Inukimon	*	1908.08.01	1653	Copper gate in front of the Taiyū-in Reibyō Hōtō.
C36	Taiyū-in Reibyō Oku-in Haiden	*	1908.08.01	1653	Building for worshipping the deity of the Oku-in.
C37	Taiyū-in Reibyō Bettōsho Ryūkō-in	*	1973.06.02	mid Edo Period	Management building for the Taiyū-in.
	C37-(1) Genkan			mid Edo Period	
Subtotal		38			
A	Futarasan-jinja	23			
B	Tōshōgū	42			
C	Rinnō-ji	38			
Total		103			

- Notes: 1. ※ The Honjūdō and the Kyōzō are in the custody of the Foundation for the Preservation of Shrines and Temples of Nikko.
2. \* \* indicates a National Treasure; \* indicates an Important Cultural Property.  
(Buildings in the inventory are listed in order of appearance in official notices of 1908 and 1944.)
3. Wooden buildings designated as accessory buildings in conjunction with National Treasures and Important Cultural Properties are listed with Hyphenated numbers at their heads.  
(Accessory buildings are not counted for the number of buildings in the inventory since they are regarded as part of the National Treasures or Important Cultural Properties they are attached to.)
4. The serial numbers of the buildings correspond to the numbers indicated in maps showing the locations or distributions of the buildings.

INVENTORY OF THE CULTURAL ASSETS; COPIES OF THE OFFICIAL DESIGNATION NOTICES

Copies of the Official Notices  
A: Futarasan-jinja

- 1 1908.08.01 Date of issue  
[A1]Honden  
[A4]Haiden
- 2 1944.09.05 Date of issue  
Change of name and descriptive data  
[A1]Honden  
[A2]Karamon  
[A3]Wakimon and Sukibé  
[A4]Haiden  
[A5]Torii  
[A6]Shinkyô  
[A7]Betsugû Takino-o-jinja Honden  
[A8]Betsugû Takino-o-jinja Karamon  
[A9]Betsugû Takino-o-jinja Haiden  
[A10]Betsugû Takino-o-jinja Rômon  
[A11]Betsugû Takino-o-jinja Torii  
[A12]Betsugû Hongû-jinja Honden  
[A13]Betsugû Hongû-jinja Karamon and Sukibé
- 3 1973.06.02 Date of issue  
Designation as Important Cultural Property  
[A14]Betsugû Hongû-jinja Haiden  
[A15]Betsugû Hongû-jinja Torii  
[A16]Shin-yosha  
[A17]Daikokuden  
[A18]Massha Mitomo-jinja Honden  
[A19]Massha Hie-jinja Honden

1

内務省告示第七十六號  
古社寺保存法第四條ニヨリ左記ノ建造物ヲ以テ特別保護建造物ノ資格ヲ得  
ノト定ム  
明治四十一年八月一日 内務大臣 法學博士朝齋平田東助

名	種	類	形	式	所在地
二荒山神社	神社	本殿	行	五間	福岡県福岡市東区
二荒山神社	神社	本殿	行	五間	福岡県福岡市東区
二荒山神社	神社	本殿	行	五間	福岡県福岡市東区

2

文部省告示第五十八號  
左記建造物ノ其ノ名稱及構造形式ノ項ノ趣旨ニ  
明治十九年九月五日  
文部大臣 西園寺公望

種別	名称	所在地	備考
神社	二荒山神社	福岡県福岡市東区	本殿 行五間
神社	二荒山神社	福岡県福岡市東区	本殿 行五間
神社	二荒山神社	福岡県福岡市東区	本殿 行五間

3

○文部省告示第百三三號  
文化財保護法(昭和二十五年法律第二百四十四號)第二十七條第一項の規定により、次の表に掲げる文化財を重要文化財に指定する。  
昭和四十八年六月二日  
文部大臣 奥野誠英

名称	種別	所在地	備考
二荒山神社	神社	福岡県福岡市東区	本殿 行五間
二荒山神社	神社	福岡県福岡市東区	本殿 行五間
二荒山神社	神社	福岡県福岡市東区	本殿 行五間







INVENTORY OF THE CULTURAL ASSETS; COPIES OF THE OFFICIAL DESIGNATION NOTICES

Copies of the Official Notices

C:Rinnô-ji

- 1 1908.08.01 Date of issue
  - [C17] Taiyû-in Reibyo Honden, Ainoma and Haiden
  - [C18] Taiyû-in Reibyo Karamon
  - [C19] Taiyû-in Reibyo Mizugaki
  - [C23] Taiyû-in Reibyo Yashamon
  - [C24] Taiyû-in Reibyo Yashamon Sayû Kairô
  - [C25] Taiyû-in Reibyo Shôrô
  - [C26] Taiyû-in Reibyo Korô
  - [C27] Taiyû-in Reibyo Nitemmon
  - [C29] Taiyû-in Reibyo Mizuya
  - [C30] Taiyû-in Reibyo Hôko
  - [C31] Taiyû-in Reibyo Niomon
  - [C32] Taiyû-in Reibyo Kôkamon
  - [C34] Taiyû-in Reibyo Oku-in Hôtô
  - [C35] Taiyû-in Reibyo Oku-in Inukimon
  - [C36] Taiyû-in Reibyo Oku-in Haiden
- 2 1917.04.05 Date of issue
  - [C1] Hondô(Sambutsudô)
- 3 1917.08.13 Date of issue
  - [C2] Sôrintô
- 4 1944.09.05 Date of issue
  - Change of name and descriptive data

内務省告示第七十六號  
古社寺保存法第四條ニ依リ左記ノ建造物ヲ以テ特別保護建造物ノ資格ヲ得  
トシ定ム  
明治四十一年八月一日 内務大臣 法學博士野澤平田奉勅

名	輪王寺大講堂
所在地	本縣行田郡行田町三丁目一ノ番地
構造	木造
形式	講堂
所在	同
所在地	同

文部省告示第七十七號  
古社寺保存法第四條ニ依リ左記ノ建造物ヲ以テ特別保護建造物ノ資格ヲ得  
トシ定ム  
大正六年八月十三日 文部大臣 岡田眞平

名	輪王寺本堂
所在地	本縣行田郡行田町三丁目一ノ番地
構造	木造
形式	本堂
所在	同
所在地	同

- 2 [C1] Hondô(Sambutsudô)
- [C2] Sôrintô
- [C3] Hombô Omotemon
- [C4] Kaizandô
- [C5] Jôgyôdô
- [C6] Hokkedô
- [C7] Jôgyôdô Hokkedô Watarirô
- [C8] Jigendô Byôdô
- [C9] Jigendô Haiden
- [C10] Jigendô Kyôzô
- [C11] Jigendô Shôrô
- [C12] Jigendô Amidadô
- [C13] Kodamadô
- [C17] Taiyû-in Reibyo Honden, Ainoma and Haiden
- [C18] Taiyû-in Reibyo Karamon
- [C19] Taiyû-in Reibyo Mizugaki
- [C20] Taiyû-in Reibyo Wakimon
- [C21] Taiyû-in Reibyo Gokûsho
- [C22] Taiyû-in Reibyo Gokûsho Watarirô
- [C23] Taiyû-in Reibyo Yashamon
- [C24] Taiyû-in Reibyo Yashamon Sayû Kairô
- [C24-(1)] Kugurimon
- [C25] Taiyû-in Reibyo Shôrô
- [C26] Taiyû-in Reibyo Korô
- [C27] Taiyû-in Reibyo Nitemmon
- [C27-(1)] Sayû Sodebê
- [C28] Taiyû-in Reibyo Saijô
- [C29] Taiyû-in Reibyo Mizuya
- [C30] Taiyû-in Reibyo Hôko
- [C31] Taiyû-in Reibyo Niomon
- [C31-(1)] Sayû Sodebê
- [C32] Taiyû-in Reibyo Kôkamon
- [C32-(1)] Sayû Sodebê
- [C33] Taiyû-in Reibyo Dôzutsumi Hôzô
- [C34] Taiyû-in Reibyo Oku-in Hôtô
- [C35] Taiyû-in Reibyo Oku-in Inukimon
- [C36] Taiyû-in Reibyo Oku-in Haiden

文部省告示第七十一號  
古社寺保存法第四條ニ依リ左記ノ建造物ヲ以テ特別保護建造物ノ資格ヲ得  
トシ定ム  
大正六年四月五日 文部大臣 岡田眞平

名	輪王寺本堂三講堂
所在地	本縣行田郡行田町三丁目一ノ番地
構造	木造
形式	本堂三講堂
所在	同
所在地	同

文部省告示第五十八號  
古社寺保存法第四條ニ依リ左記ノ建造物ヲ以テ特別保護建造物ノ資格ヲ得  
トシ定ム  
昭和十九年九月五日 文部大臣 二宮 哲彦

名	輪王寺本堂
所在地	本縣行田郡行田町三丁目一ノ番地
構造	木造
形式	本堂
所在	同
所在地	同

文部省告示第七十二號  
古社寺保存法第四條ニ依リ左記ノ建造物ヲ以テ特別保護建造物ノ資格ヲ得  
トシ定ム  
大正六年四月五日 文部大臣 岡田眞平

名	輪王寺本堂
所在地	本縣行田郡行田町三丁目一ノ番地
構造	木造
形式	本堂
所在	同
所在地	同





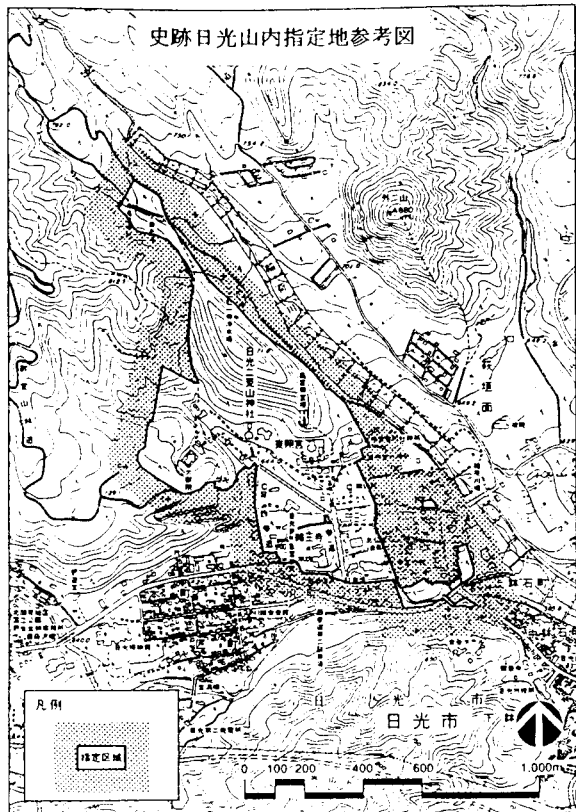

○文部省告示第八十九号  
文化財保護法（昭和二十五年法律第二百十四号）  
第六十九条第一項の規定により、次に掲げる紀章  
物を史跡に指定する。  
平成十年五月十四日  
文部大臣 町村 信孝  
名称 所在地  
日光山内 栃木県日光市 別荘地  
備考 別荘地を略し栃木県教育委員会及び日光市  
教育委員会に譲り渡し、管理に供する。参考図  
参照。

## APPENDIX 4-b-7

INVENTORY OF THE CULTURAL  
ASSETS; COPIES OF THE OFFICIAL  
DESIGNATION NOTICES

Copies of the Official Notices

D: Cultural Landscape

1 1998.05.14 Date of issue  
Designation as  
Historic Site

**APPENDIX 5-a-1**

DRAWINGS OF THE MAJOR BUILDINGS  
(NATIONAL TREASURES AND  
IMPORTANT CULTURAL PROPERTIES)

A:Futarasan-jinja  
Honden [A1]

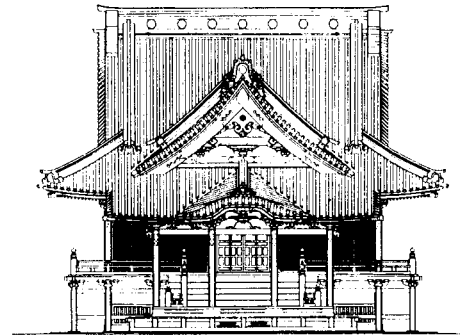
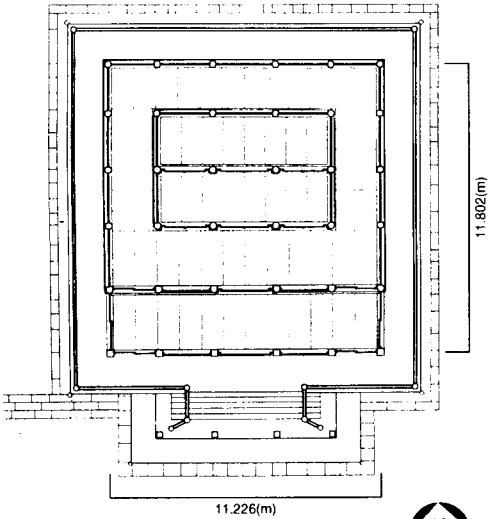

2

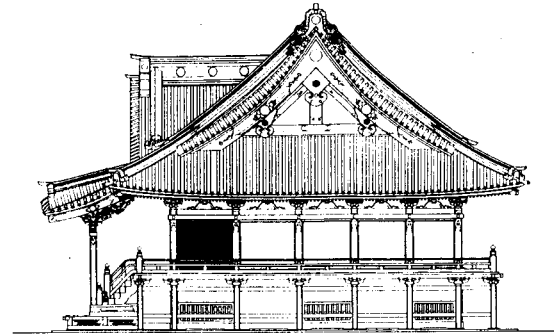

3

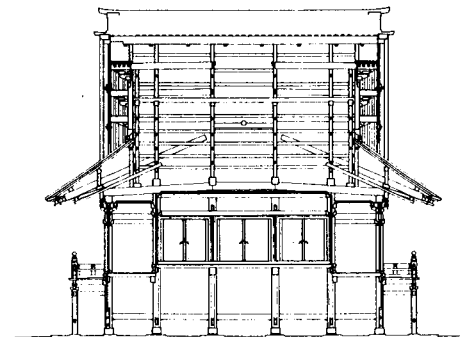

4

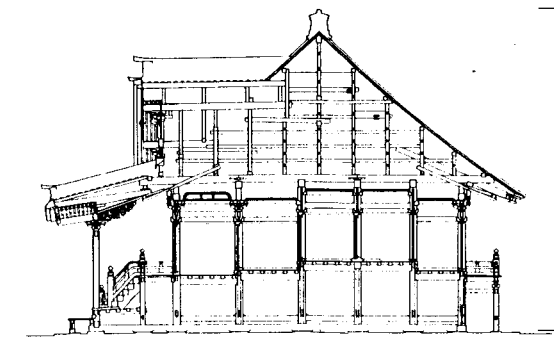

5

- 1 Plan
- 2 Elevation(front)
- 3 Elevation(side)
- 4 Section(front)
- 5 Section(side)

SCALE 1:200

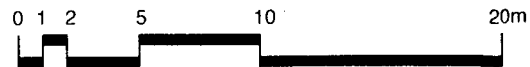

JAPAN/NIKKO

**APPENDIX 5-a-2**

DRAWINGS OF THE MAJOR BUILDINGS  
(NATIONAL TREASURES AND  
IMPORTANT CULTURAL PROPERTIES)

A:Futarasan-jinja  
Haiden [A4]

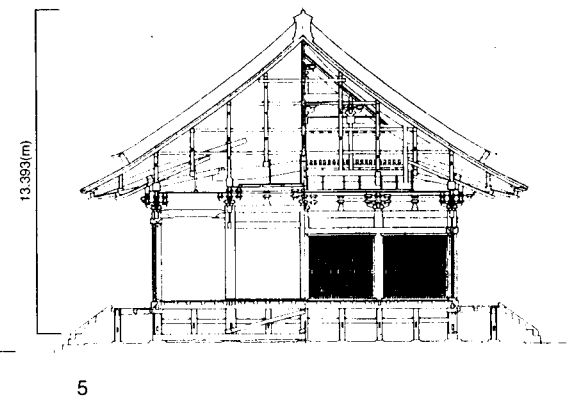
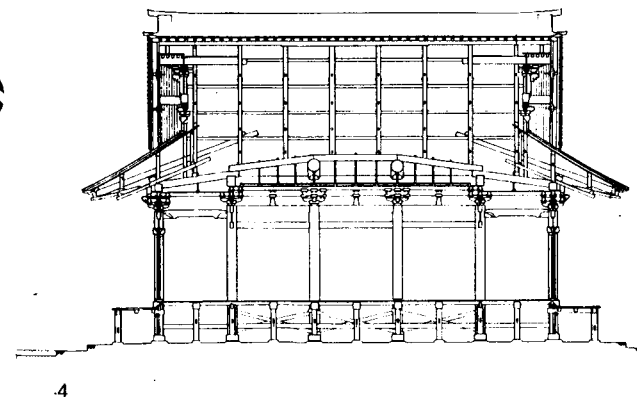
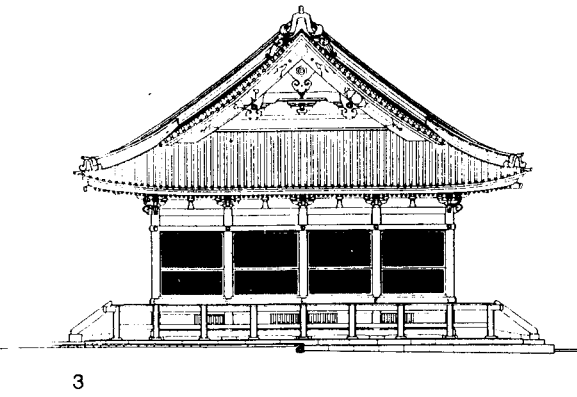
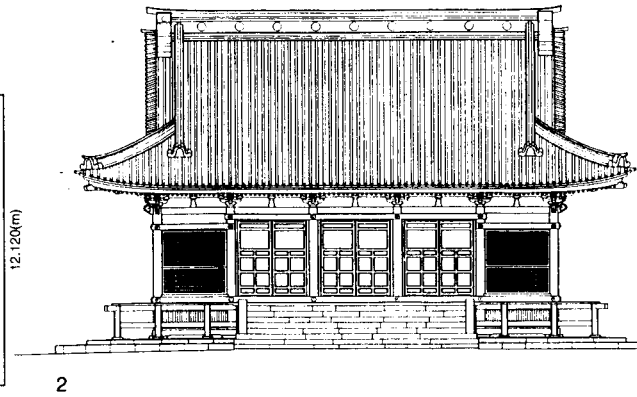
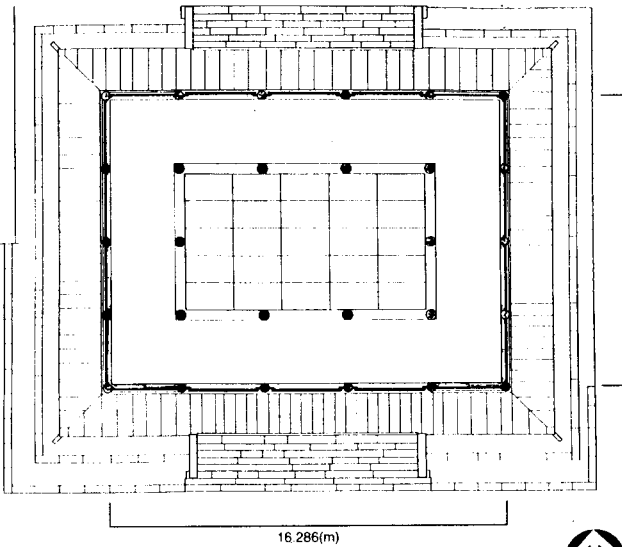

- 1 Plan
- 2 Elevation(front)
- 3 Elevation(side)
- 4 Section(front)
- 5 Section(side)



**APPENDIX 5-a-3**

DRAWINGS OF THE MAJOR BUILDINGS  
(NATIONAL TREASURES AND  
IMPORTANT CULTURAL PROPERTIES)

A:Futarasan-jinja  
Shinkyō [A6]

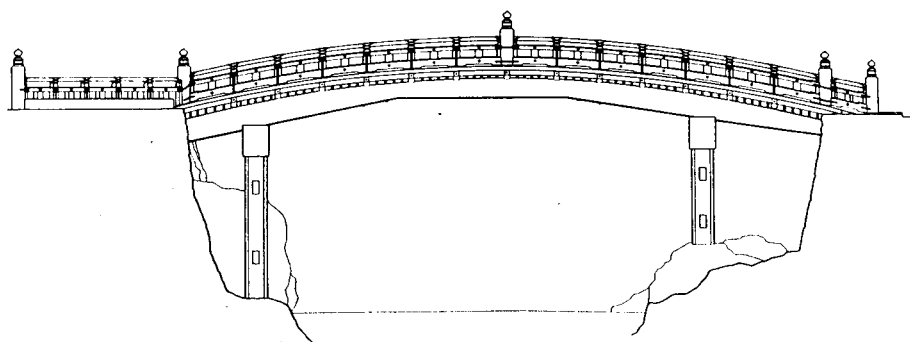
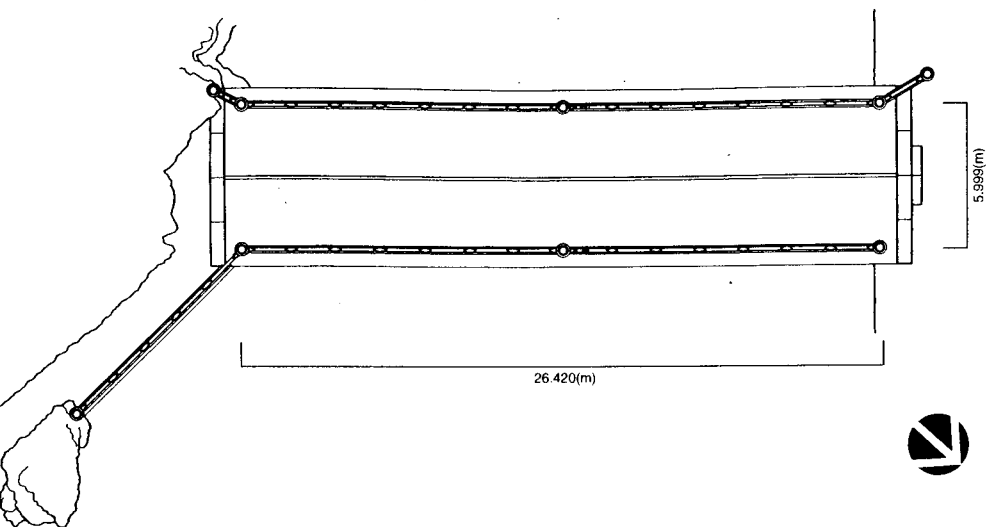

2

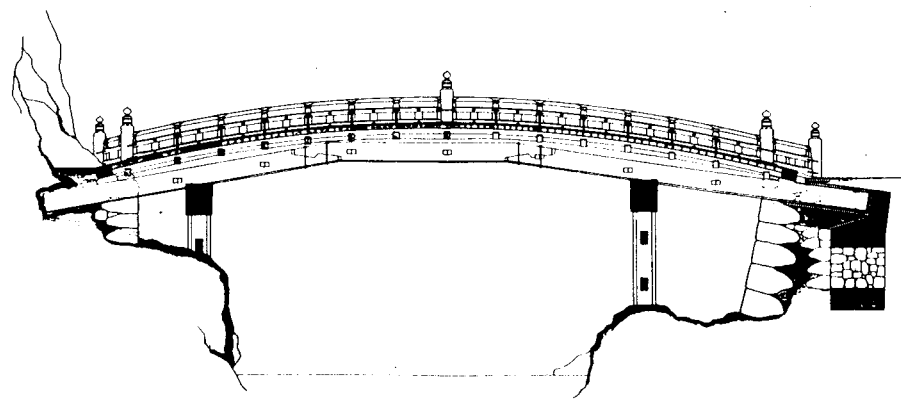

3

SCALE 1:200



- 1 Plan
- 2 Elevation
- 3 Section

**JAPAN / NIKKO**

# APPENDIX 5-a-4

DRAWINGS OF THE MAJOR BUILDINGS  
(NATIONAL TREASURES AND  
IMPORTANT CULTURAL PROPERTIES)

A: Futarasan-jinja  
Betsugū Takino-o-jinja Honden [A7]  
Betsugū Hongū-jinja Honden [A12]

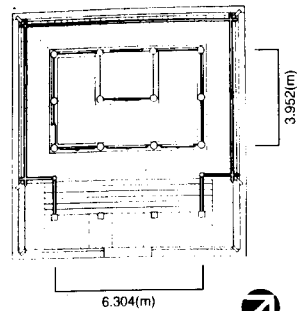

1

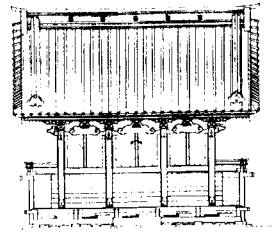

2

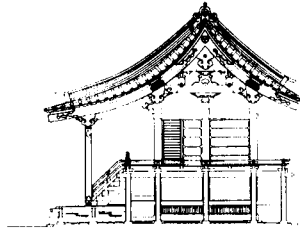

3

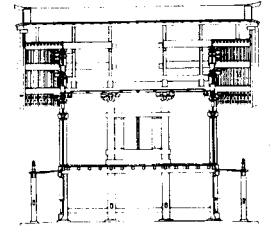

4

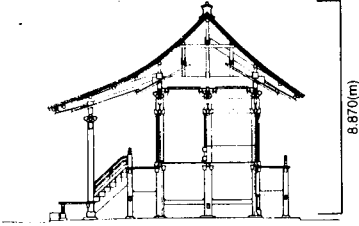

5

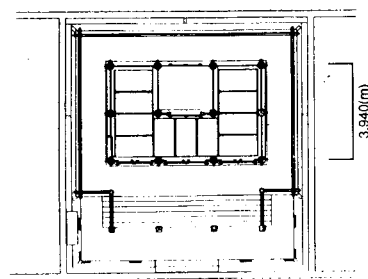

6

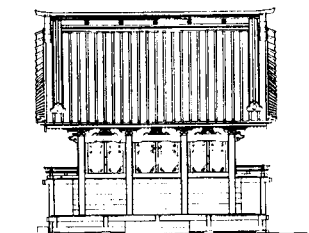

7

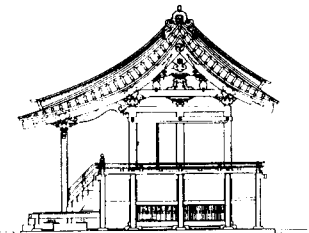

8

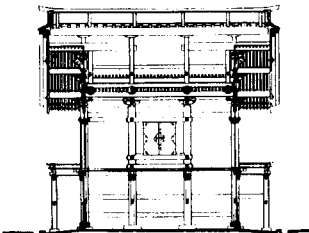

9

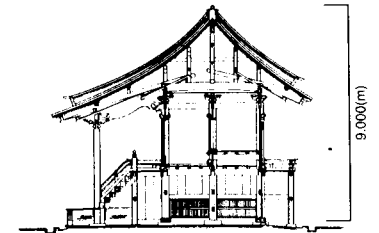

10

Betsugū Takino-o-jinja Honden  
1 Plan  
2 Elevation(front)  
3 Elevation(side)  
4 Section(front)  
5 Section(side)

Betsugū Hongū-jinja Honden  
6 Plan  
7 Elevation(front)  
8 Elevation(side)  
9 Section(front)  
10 Section(side)

SCALE 1:200

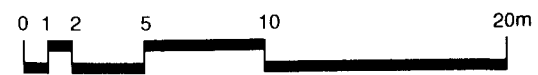

JAPAN / NIKKO

# APPENDIX 5-a-5

DRAWINGS OF THE MAJOR BUILDINGS  
(NATIONAL TREASURES AND  
IMPORTANT CULTURAL PROPERTIES)

A:Futarasan-jinja  
Shin-yosha [A16]

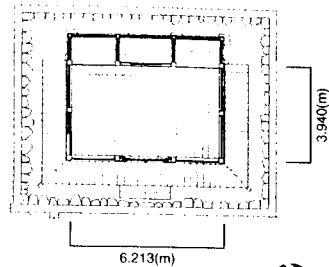

1

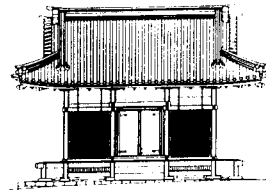

2

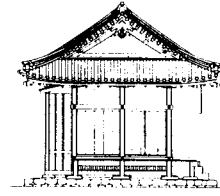

3

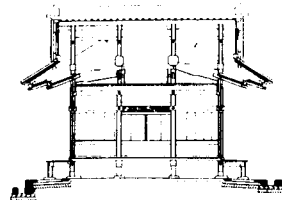

4

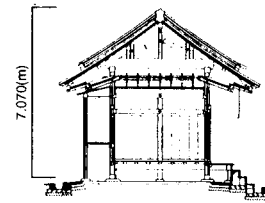

5

SCALE 1:200

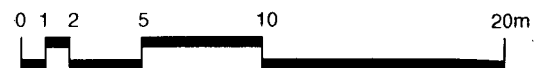

- 1 Plan
- 2 Elevation(front)
- 3 Elevation(side)
- 4 Section(front)
- 5 Section(side)

**APPENDIX 5-b-1**

DRAWINGS OF THE MAJOR BUILDINGS  
(NATIONAL TREASURES AND  
IMPORTANT CULTURAL PROPERTIES)

B: Tōshōgū  
Honden, Ishinoma and Haiden [B1]

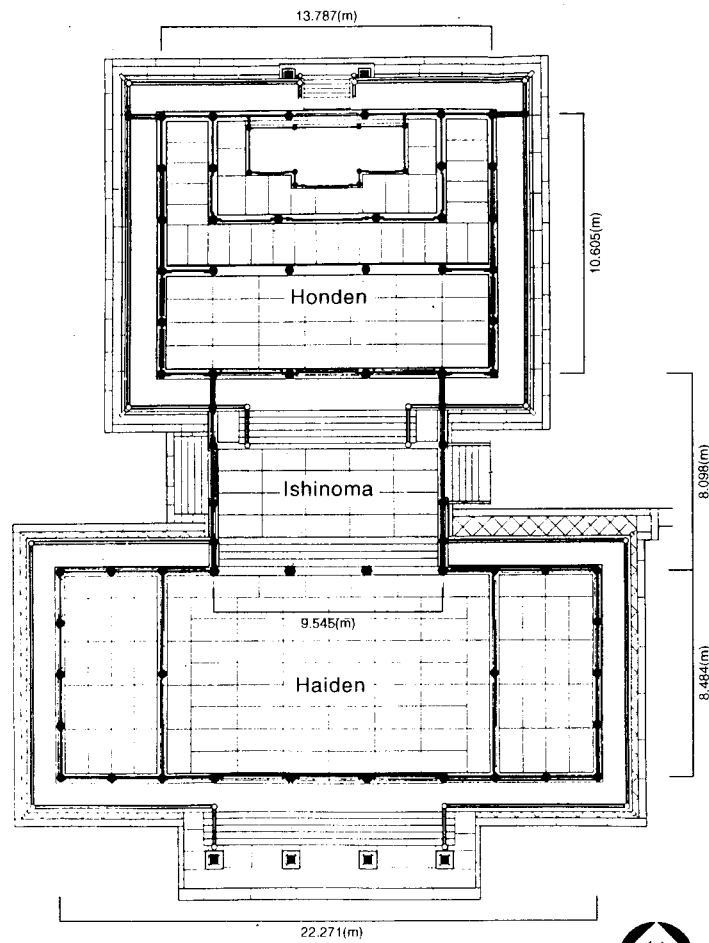

1



SCALE 1:200

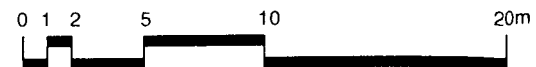

1 Plan

JAPAN / NIKKO



**APPENDIX 5-b-2**

DRAWINGS OF THE MAJOR BUILDINGS  
(NATIONAL TREASURES AND  
IMPORTANT CULTURAL PROPERTIES)

B:Tōshōgū

Honden, Ishinoma and Haiden [B1]

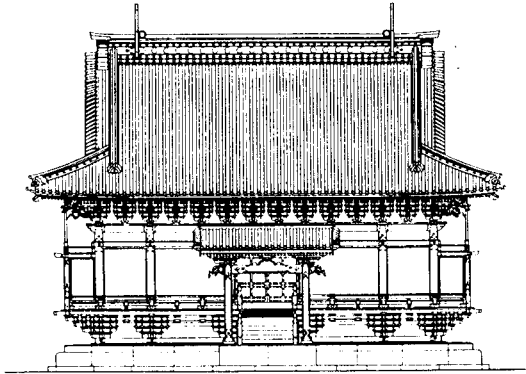

2

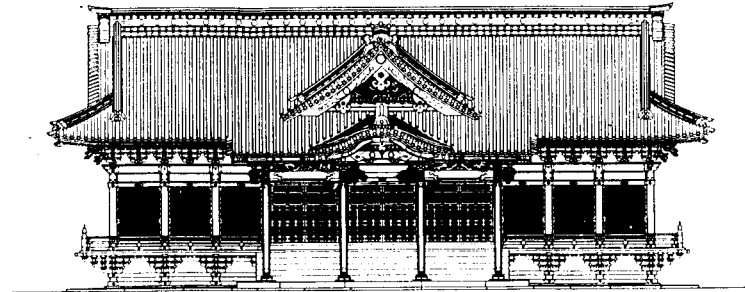

4

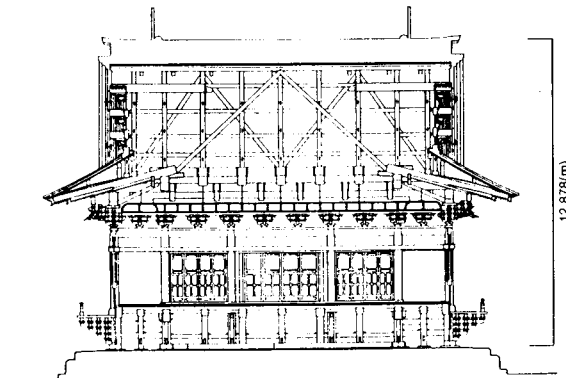

3

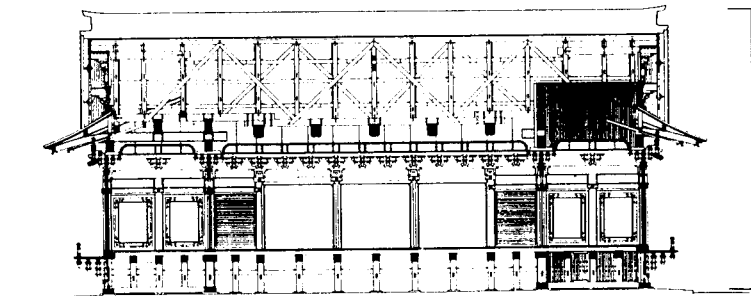

5

Honden  
2 Elevation(back)  
3 Section(back)

Haiden  
4 Elevation(front)  
5 Section(front)

SCALE 1:200

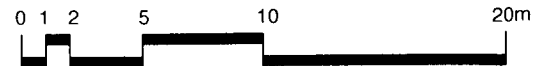

JAPAN / NIKKO

**APPENDIX 5-b-3**

DRAWINGS OF THE MAJOR BUILDINGS  
(NATIONAL TREASURES AND  
IMPORTANT CULTURAL PROPERTIES)

B:Tôshôgû  
Honden,Ishinoma and Haiden [B1]

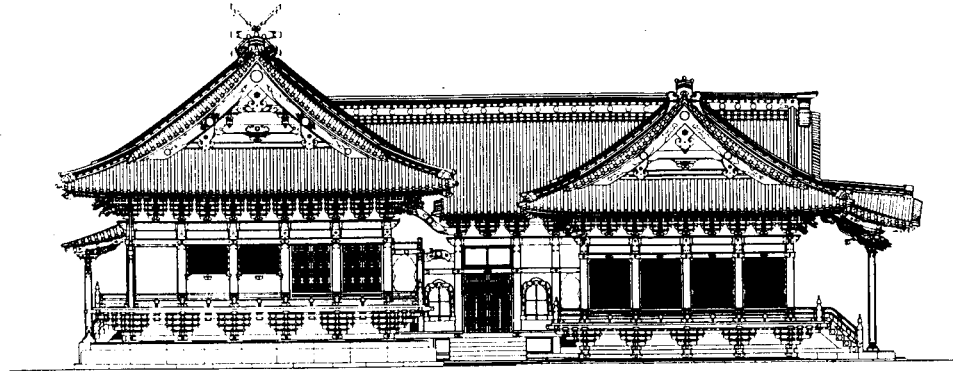

6

Honden

Ishinoma

Haiden

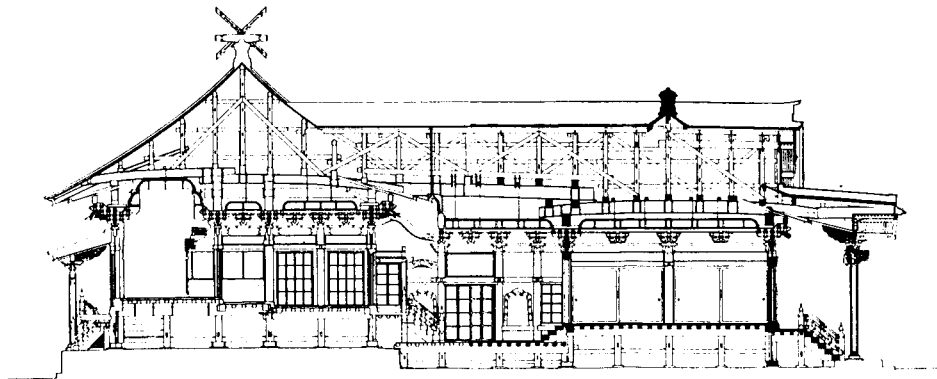

7

Honden

Ishinoma

Haiden

SCALE 1:200

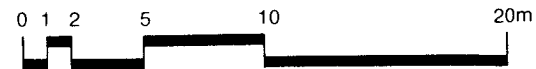

6 Elevation(side)  
7 Section(side)

**JAPAN / NIKKO**

# APPENDIX 5 - b - 4

DRAWINGS OF THE MAJOR BUILDINGS  
(NATIONAL TREASURES AND  
IMPORTANT CULTURAL PROPERTIES)

B: Tōshōgū

Shōmen Karamon [B2]

Haimen Karamon [B2]

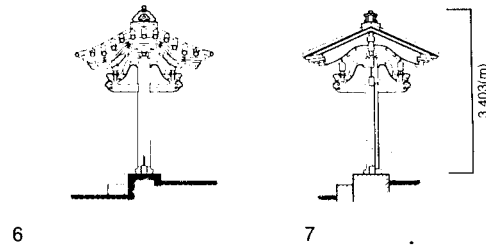
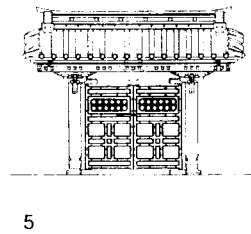
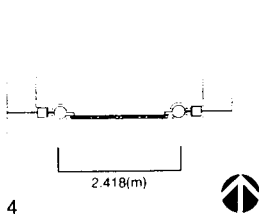
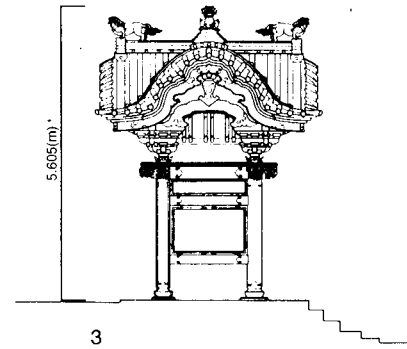
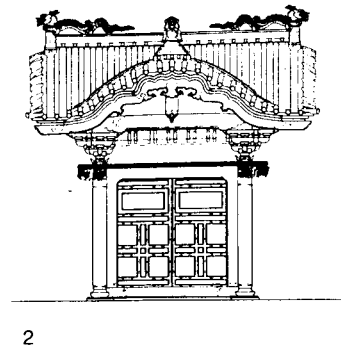
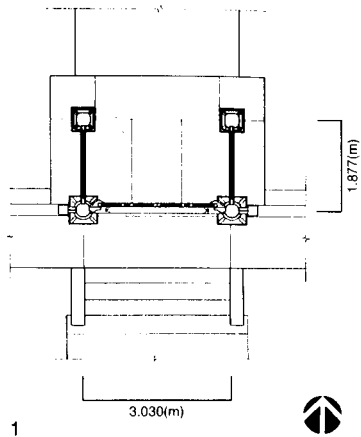

Shōmen Karamon

1 Plan

2 Elevation(front)

3 Elevation(side)

Haimen Karamon

4 Plan

5 Elevation(front)

6 Elevation(side)

7 Section(side)

SCALE 1:100



JAPAN / NIKKO

**APPENDIX 5-b-5**

DRAWINGS OF THE MAJOR BUILDINGS  
(NATIONAL TREASURES AND  
IMPORTANT CULTURAL PROPERTIES)

B:Tôshôgû  
Tôzai Sukibê [B3]

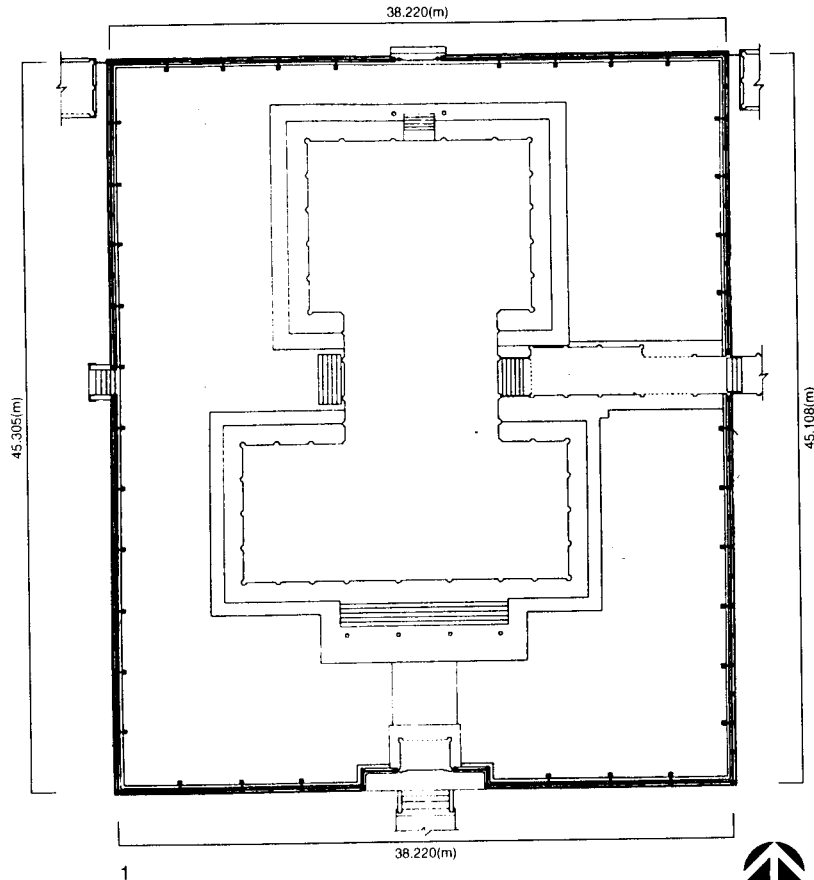

SCALE 1:300

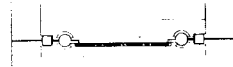

2

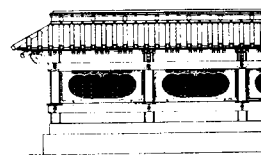

3

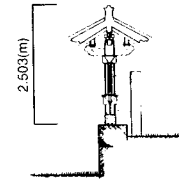

4

SCALE 1:100

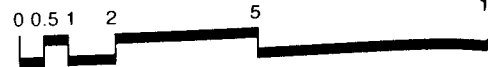

- 1 Plan(total)
- 2 Plan(unit)
- 3 Elevation
- 4 Section

**JAPAN/NIKKO**

**APPENDIX 5-b-6**

DRAWINGS OF THE MAJOR BUILDINGS  
(NATIONAL TREASURES AND  
IMPORTANT CULTURAL PROPERTIES)

B:Tôshôgû

Yômeimon [B4]

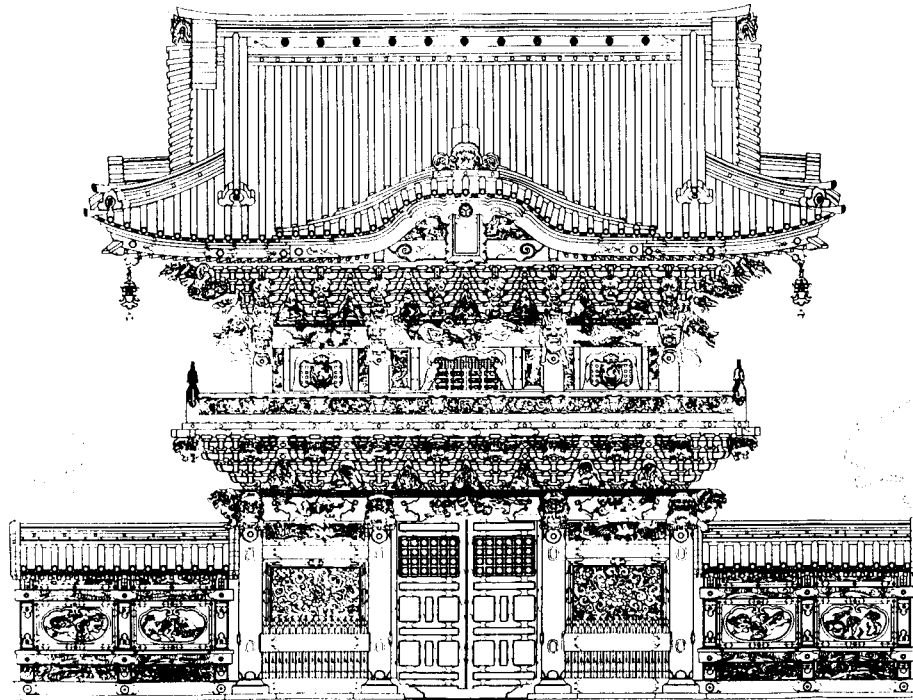

1

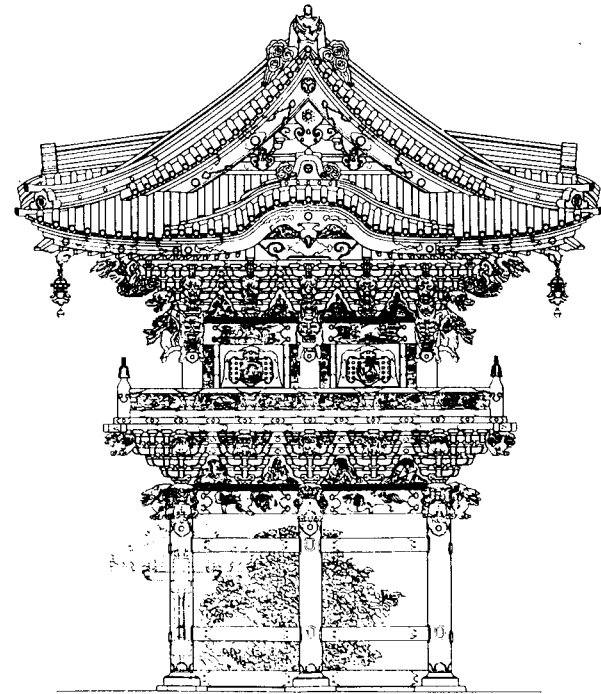

2

SCALE 1:80

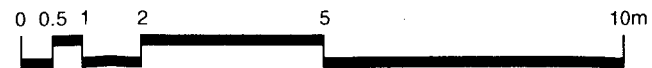

1 Elevation(front)  
2 Elevation(side)

**JAPAN/NIKKO**

**APPENDIX 5-b-7**

DRAWINGS OF THE MAJOR BUILDINGS  
(NATIONAL TREASURES AND  
IMPORTANT CULTURAL PROPERTIES)

B:Tôshôgû  
Yômeimon [B4]

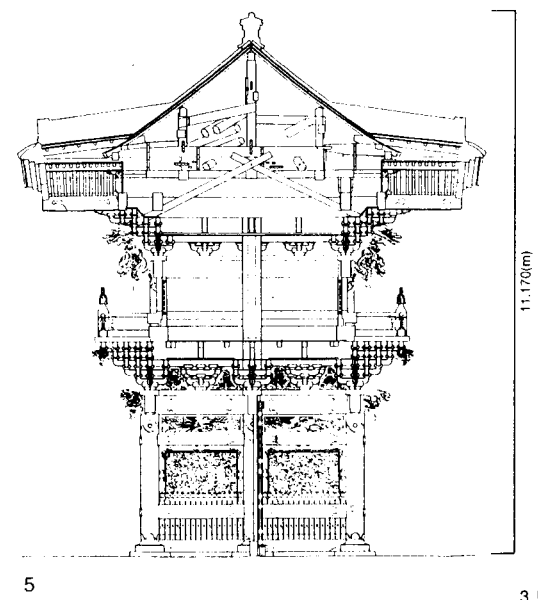
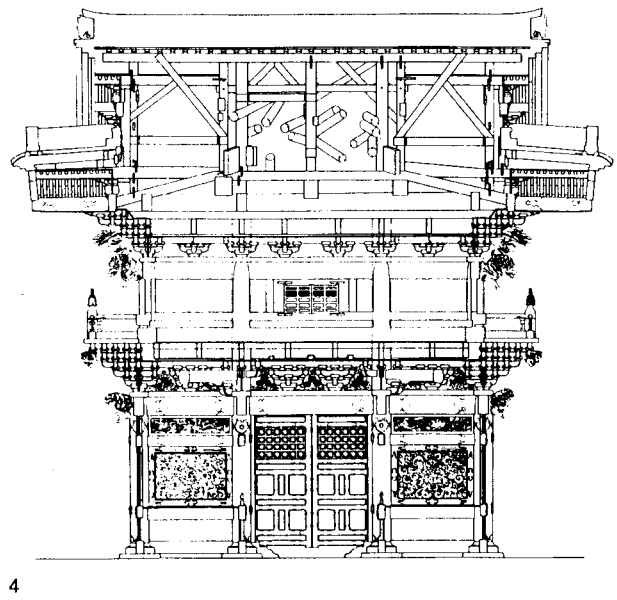
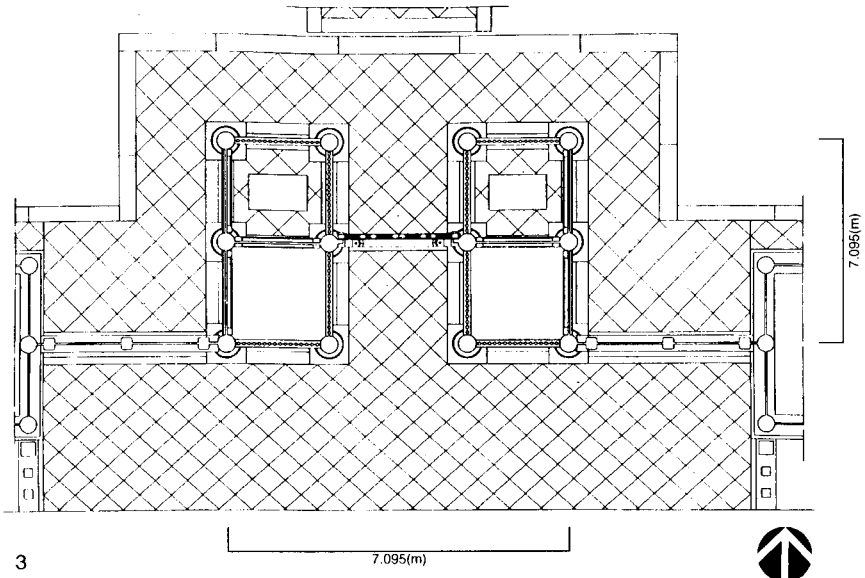

SCALE 1:100

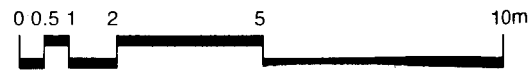

3 Plan  
4 Section(front)  
5 Section(side)

# APPENDIX 5 - b - 8

DRAWINGS OF THE MAJOR BUILDINGS  
(NATIONAL TREASURES AND  
IMPORTANT CULTURAL PROPERTIES)

B:Tôshôgû

Tôzai Kairô [B5]

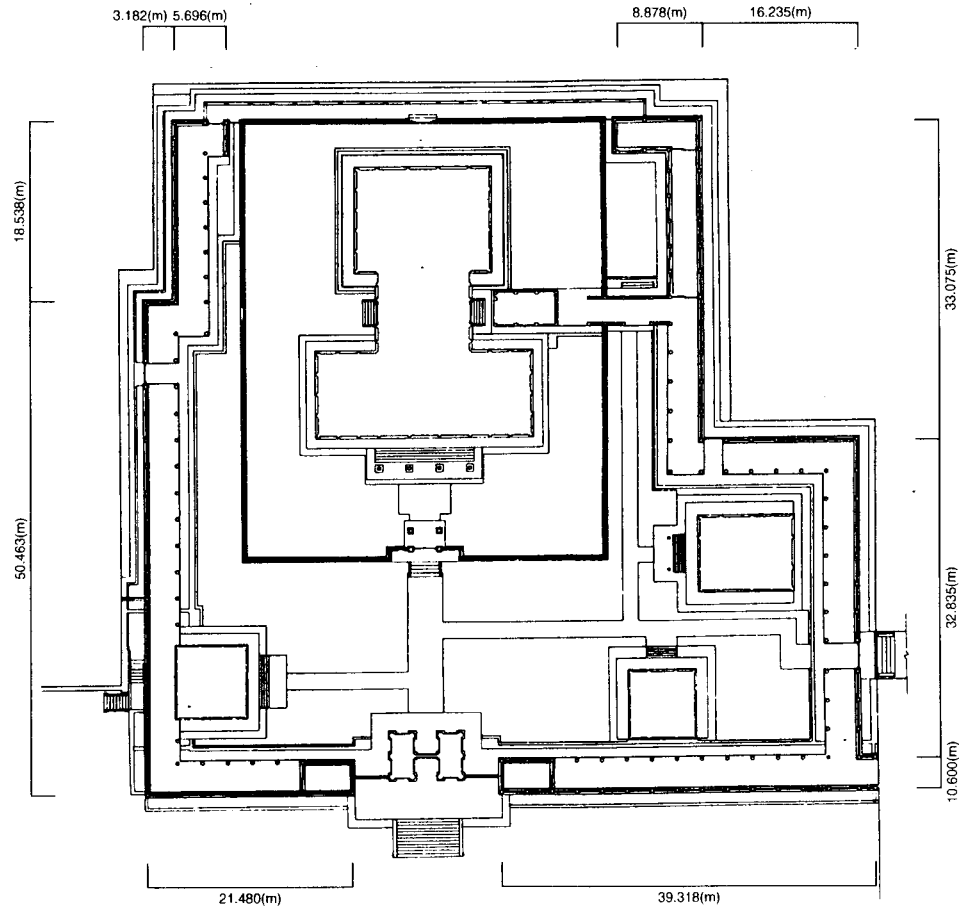

SCALE 1:500



1 Plan

JAPAN / NIKKO

**APPENDIX 5-b-9**

DRAWINGS OF THE MAJOR BUILDINGS  
(NATIONAL TREASURES AND  
IMPORTANT CULTURAL PROPERTIES)

B:Tōshōgū  
Tōzai Kairō [B5]

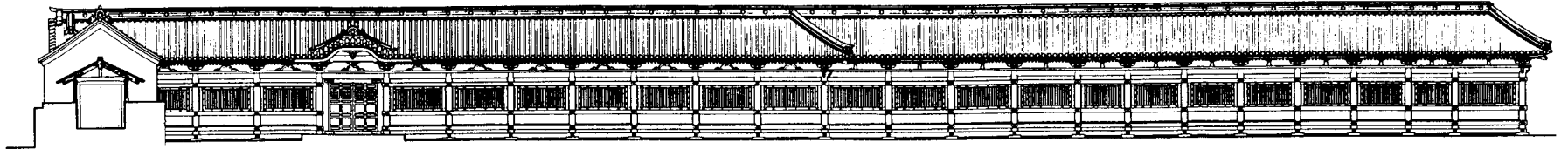

2

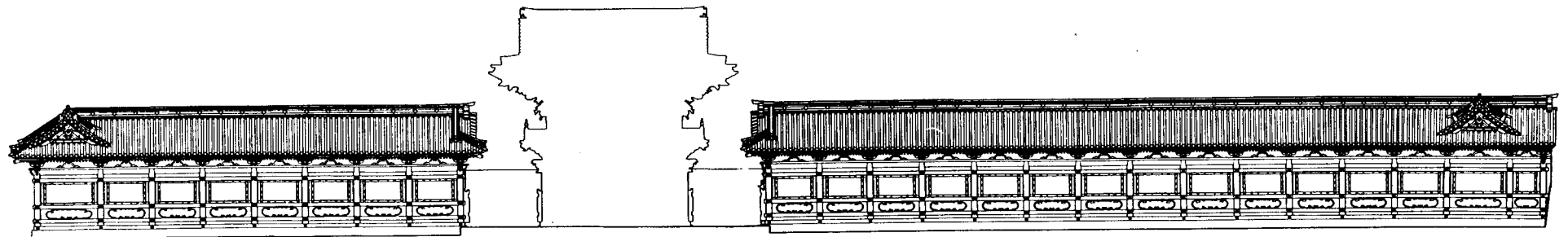

3

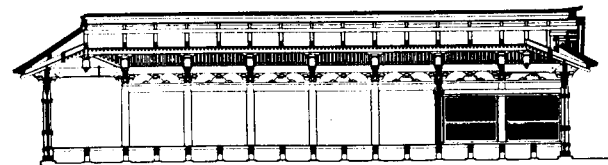

4

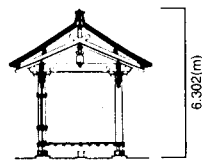

5

SCALE 1:200

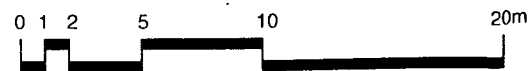

- 2 Elevation(eastern part)
- 3 Elevation(southern part)
- 4 Section(southern part)
- 5 Section(southern part)

**JAPAN / NIKKO**



# APPENDIX 5-b-10

DRAWINGS OF THE MAJOR BUILDINGS  
(NATIONAL TREASURES AND  
IMPORTANT CULTURAL PROPERTIES)

B:Tôshôgû  
Mizuya [B16]  
Shinkyû [B17]

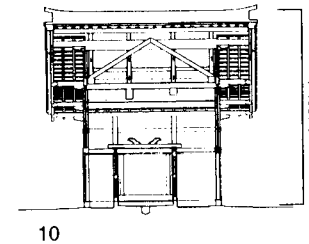
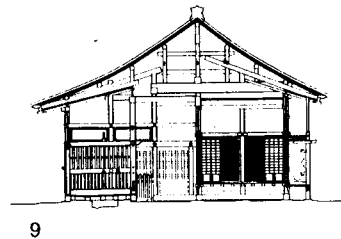
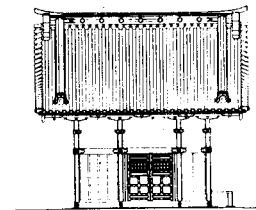
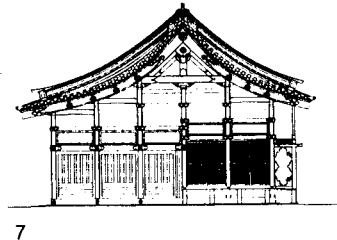
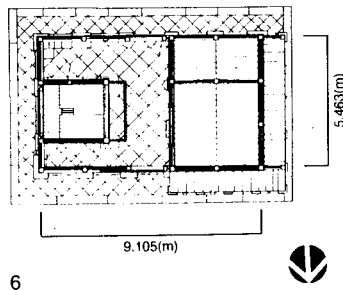
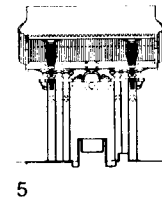
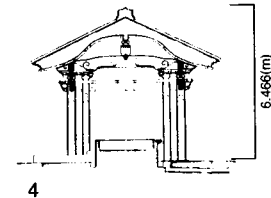
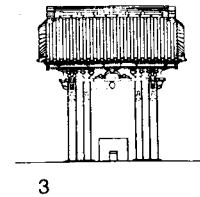
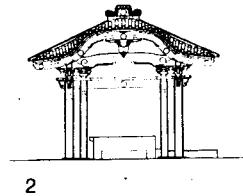
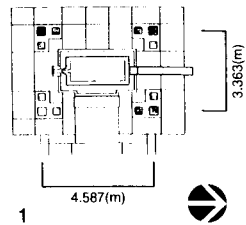

Mizuya  
1 Plan  
2 Elevation(front)  
3 Elevation(side)  
4 Section(front)  
5 Section(side)

Shinkyû  
6 Plan  
7 Elevation(front)  
8 Elevation(side)  
9 Section(front)  
10 Section(side)

SCALE 1:200



**APPENDIX 5-b-11**

DRAWINGS OF THE MAJOR BUILDINGS  
(NATIONAL TREASURES AND  
IMPORTANT CULTURAL PROPERTIES)

B: Tōshōgū  
Gojūnotō [B19]

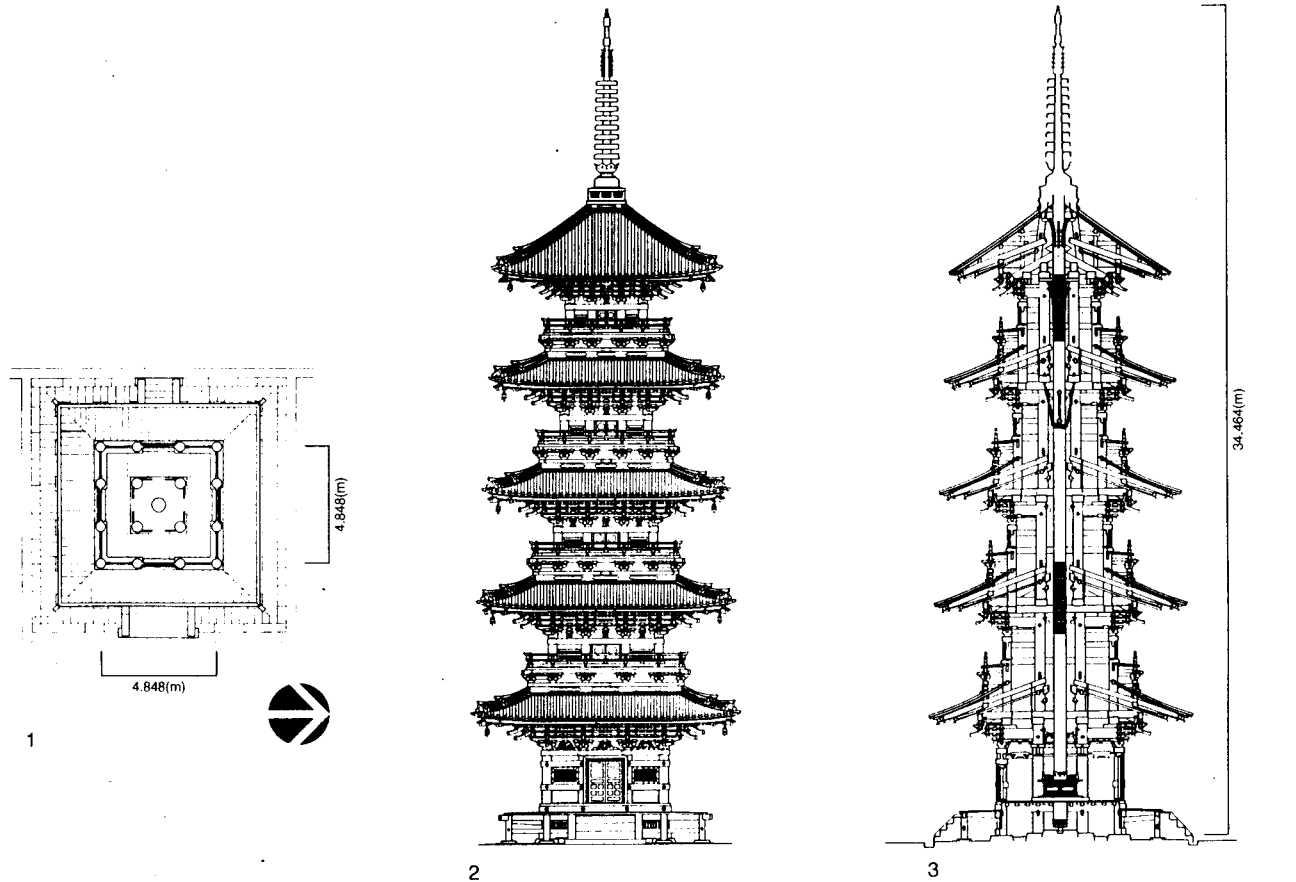

SCALE 1:200



1 Plan  
2 Elevation(front)  
3 Section(side)

**JAPAN/NIKKO**

# APPENDIX 5-b-12

DRAWINGS OF THE MAJOR BUILDINGS  
(NATIONAL TREASURES AND  
IMPORTANT CULTURAL PROPERTIES)

B: Tôshôgû

Ishidorii [B20]

Sakashitamon [B21]

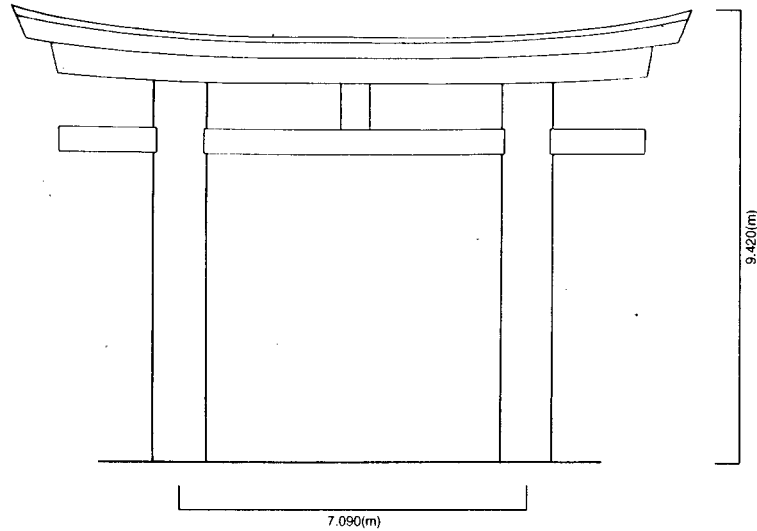

1

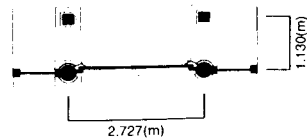

2

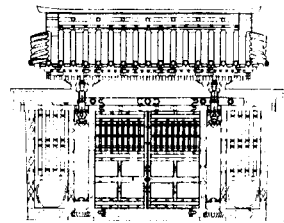

3

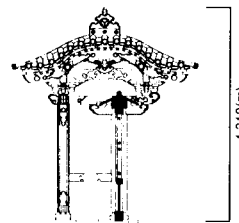

4

SCALE 1:100

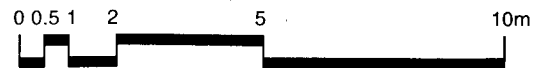

Ishidorii  
1 Elevation

Sakashitamon  
2 Plan  
3 Elevation(front)  
4 Elevation(side)

JAPAN/NIKKO

# APPENDIX 5-b-13

DRAWINGS OF THE MAJOR BUILDINGS  
(NATIONAL TREASURES AND  
IMPORTANT CULTURAL PROPERTIES)

B:Tôshôgû

Okusha Hôtô [B22]

Otabisho Honden [B34]

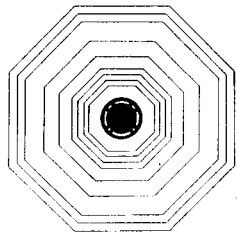

1



2

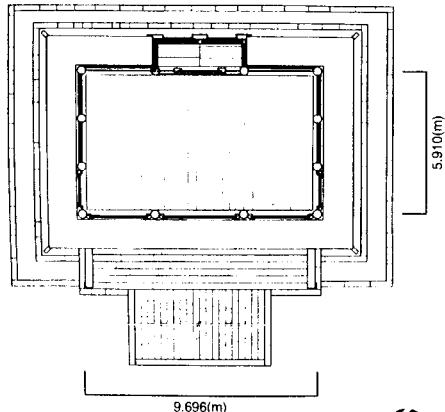

3

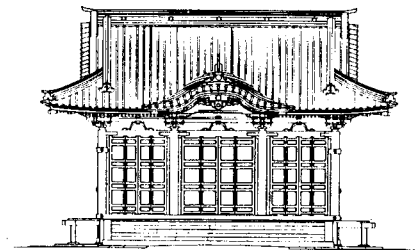

4

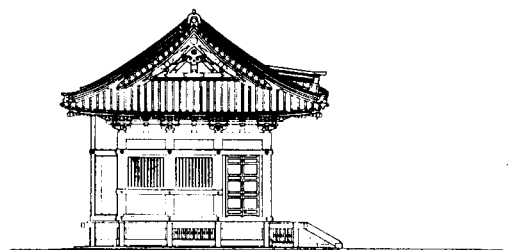

5

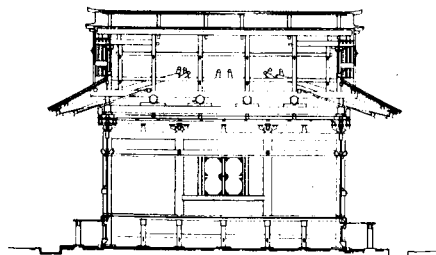

6

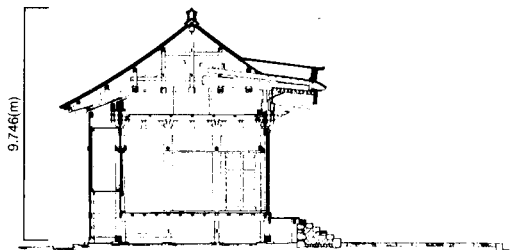

7

SCALE 1:200

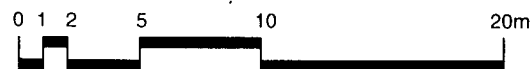

Okusha Hôtô

1 Plan

2 Elevation(front)

Otabisho Honden

3 Plan

4 Elevation(front)

5 Elevation(side)

6 Section(front)

7 Section(side)

JAPAN/NIKKO

**APPENDIX 5-c-1**

DRAWINGS OF THE MAJOR BUILDINGS  
(NATIONAL TREASURES AND  
IMPORTANT CULTURAL PROPERTIES)

C:Rinnō-ji  
Hondō(Sambutsudō) [C1]

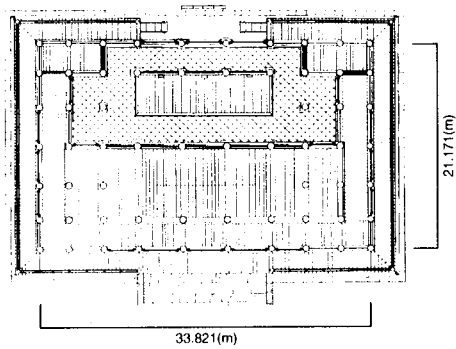

1

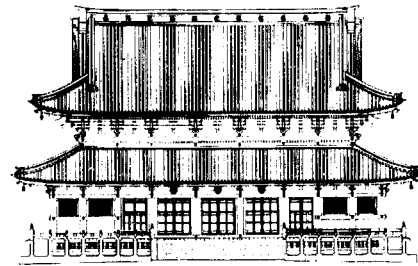

2

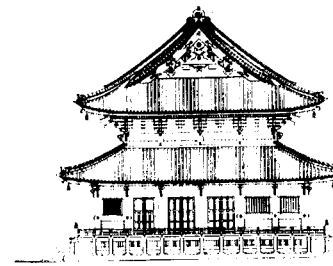

3

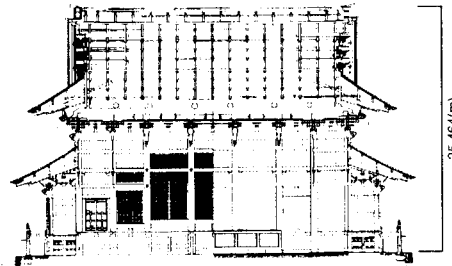

4

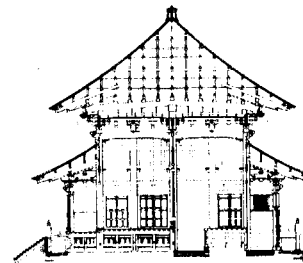

5

- 1 Plan
- 2 Elevation(front)
- 3 Elevation(side)
- 4 Section(front)
- 5 Section(side)

SCALE 1:500



JAPAN / NIKKO

**APPENDIX 5-c-2**

DRAWINGS OF THE MAJOR BUILDINGS  
(NATIONAL TREASURES AND  
IMPORTANT CULTURAL PROPERTIES)

C:Rinnō-ji  
Kaizandō [C4]

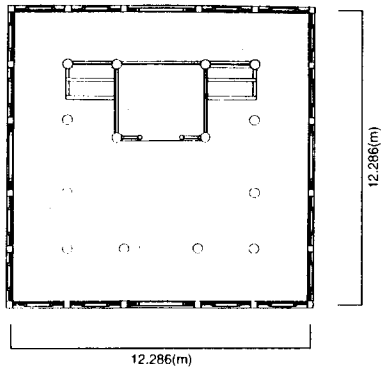

1

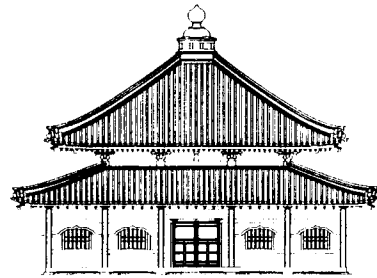

2

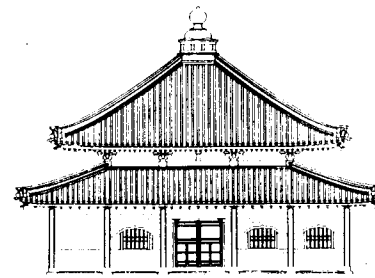

3

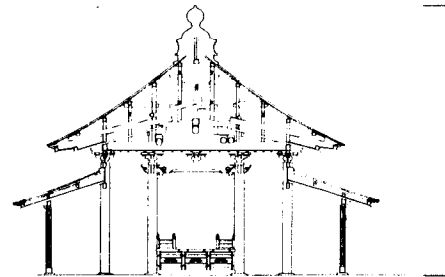

4

SCALE 1:200

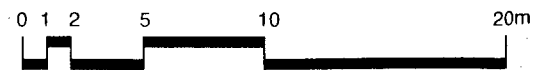

- 1 Plan
- 2 Elevation(front)
- 3 Elevation(side)
- 4 Section(front)

**APPENDIX 5-c-3**

DRAWINGS OF THE MAJOR BUILDINGS  
(NATIONAL TREASURES AND  
IMPORTANT CULTURAL PROPERTIES)

C:Rinnō-ji  
Jōgyōdō [C5]

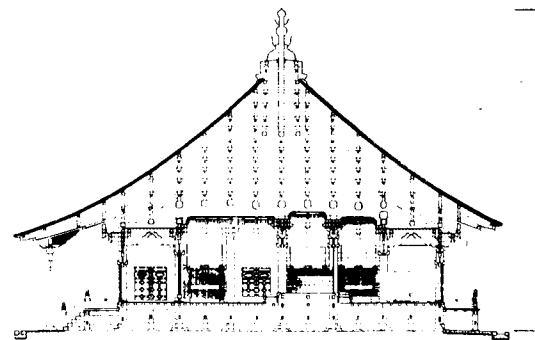
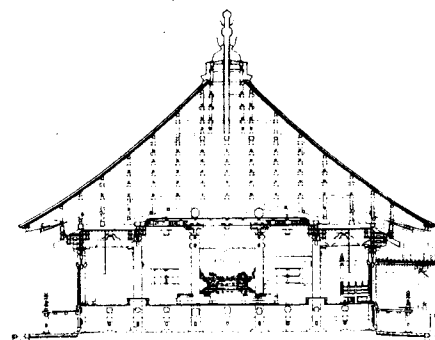
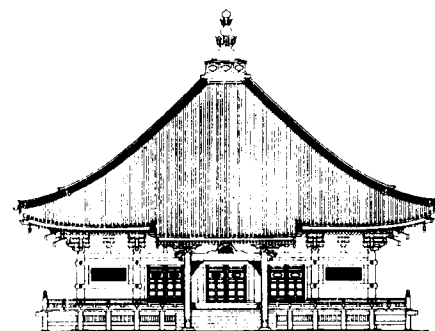
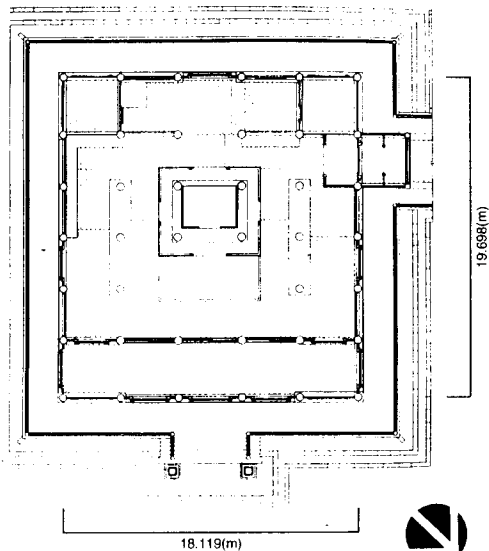

- 1 Plan
- 2 Elevation(front)
- 3 Elevation(side)
- 4 Section(front)
- 5 Section(side)

SCALE 1:300



**APPENDIX 5-c-4**

DRAWINGS OF THE MAJOR BUILDINGS  
(NATIONAL TREASURES AND  
IMPORTANT CULTURAL PROPERTIES)

C:Rinnō-ji  
Hokkedō [C6]

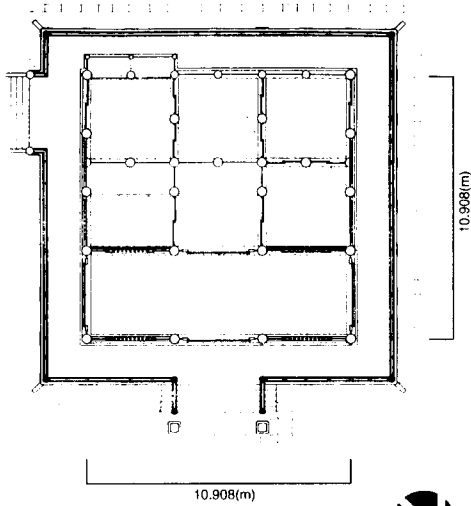

1

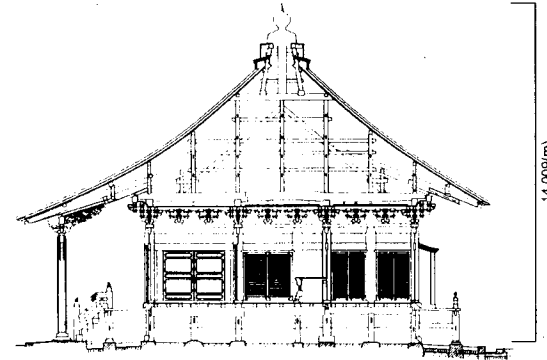
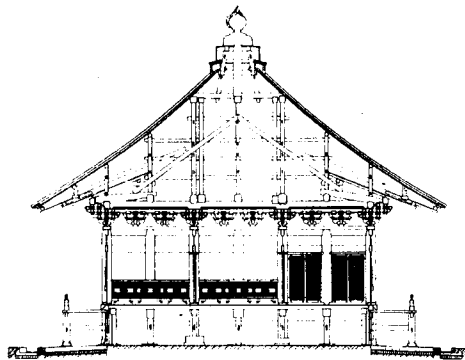
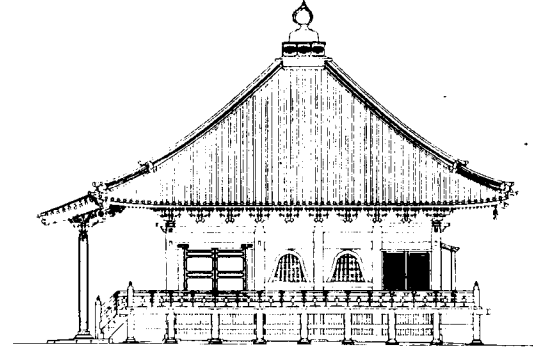
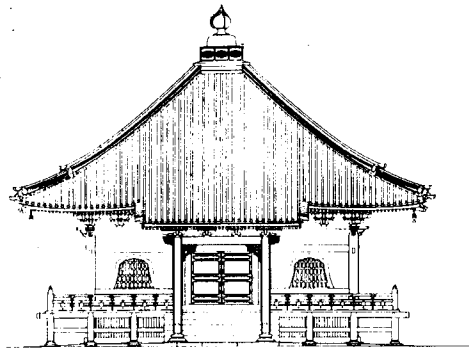

- 1 Plan
- 2 Elevation(front)
- 3 Elevation(side)
- 4 Section(front)
- 5 Section(side)

SCALE 1:200

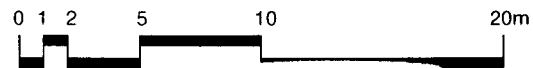



**APPENDIX 5-c-5**

DRAWINGS OF THE MAJOR BUILDINGS  
(NATIONAL TREASURES AND  
IMPORTANT CULTURAL PROPERTIES)

C:Rinnō-ji  
Sanjūnotō [C16]

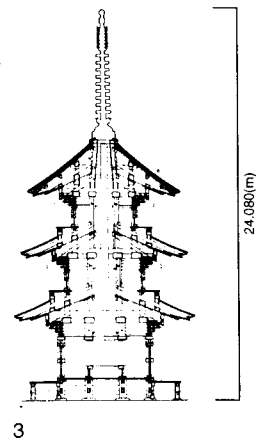
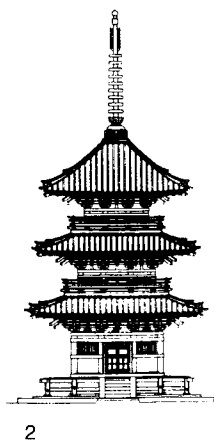
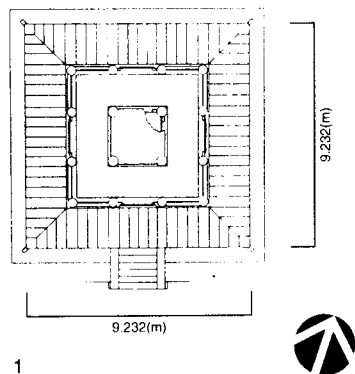

SCALE 1:200



- 1 Plan
- 2 Elevation(front)
- 3 Section(front)

**APPENDIX 5-c-6**

DRAWINGS OF THE MAJOR BUILDINGS  
(NATIONAL TREASURES AND  
IMPORTANT CULTURAL PROPERTIES)

C:Rinnō-ji

Taiyū-in Reibyō

Honden, Ainoma and Haiden [C17]

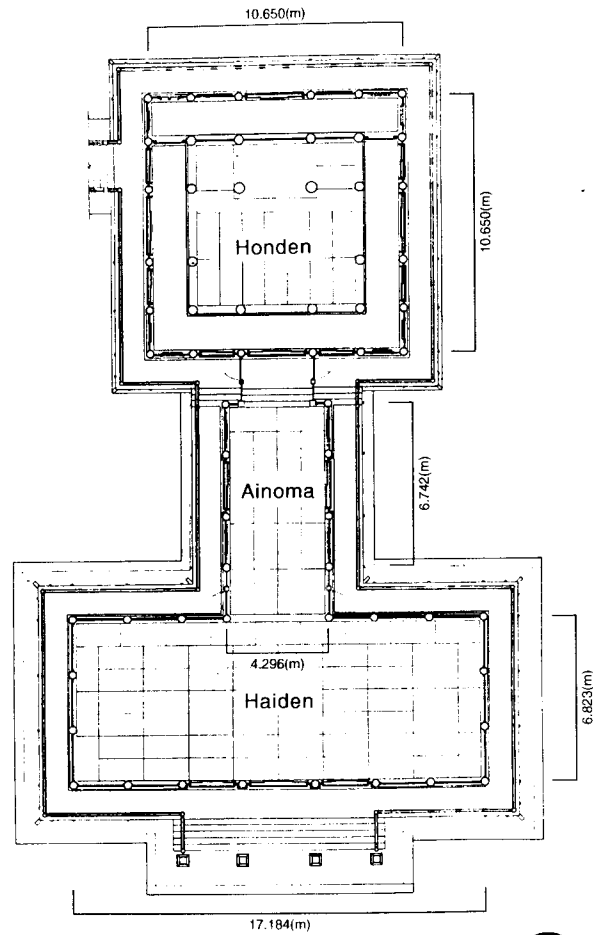

1



SCALE 1:200

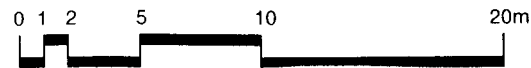

1 Plan

JAPAN/NIKKO

**APPENDIX 5-c-7**

DRAWINGS OF THE MAJOR BUILDINGS  
(NATIONAL TREASURES AND  
IMPORTANT CULTURAL PROPERTIES)

C:Rinnō-ji  
Taiyū-in Reibyō  
Honden, Ainoma and Haiden [C17]

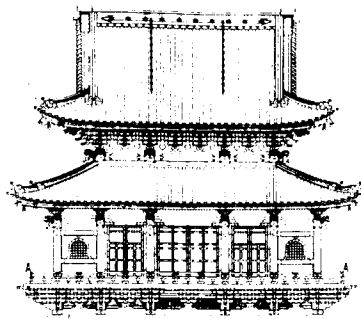

2

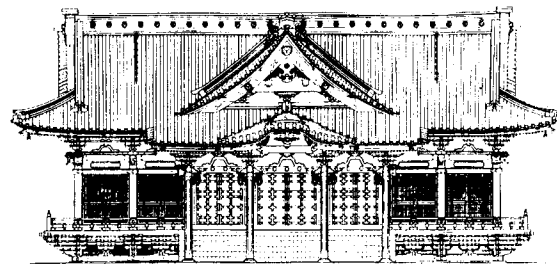

3

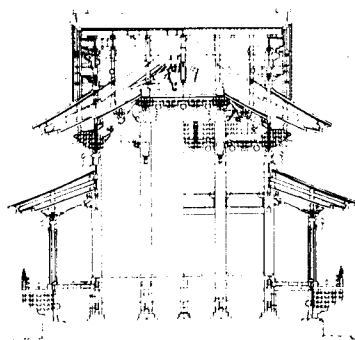

4

12.771(m)

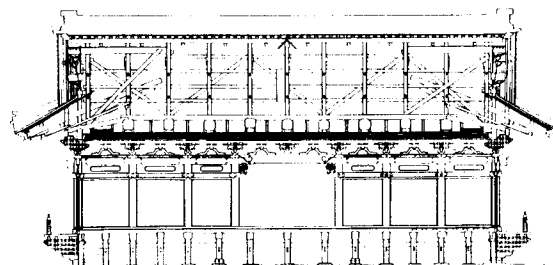

5

10.302(m)

Honden  
2 Elevation(back)  
3 Section(back)

Haiden  
4 Elevation(front)  
5 Section(front)

SCALE 1:200

0 1 2 5 10 20m

**APPENDIX 5-c-8**

DRAWINGS OF THE MAJOR BUILDINGS  
(NATIONAL TREASURES AND  
IMPORTANT CULTURAL PROPERTIES)

C:Rinnō-ji  
Taiyū-in Reibyō  
Honden, Ainoma and Haiden [C17]

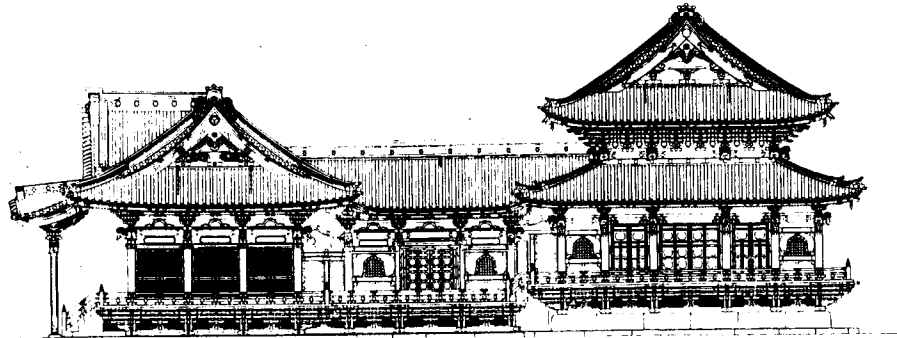

6 Haiden Ainoma Honden

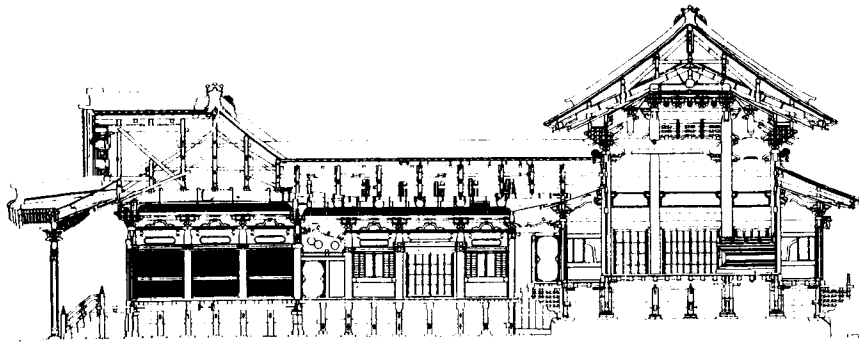

7 Haiden Ainoma Honden

SCALE 1:200

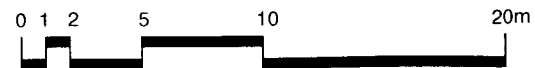

6 Elevation(side)  
7 Section(side)

# APPENDIX 5-c-9

DRAWINGS OF THE MAJOR BUILDINGS  
(NATIONAL TREASURES AND  
IMPORTANT CULTURAL PROPERTIES)

C:Rinnô-ji

Taiyû-in Reibyô

Karamon [C18]

Yashamon [C23]

Kôkamon [C32]

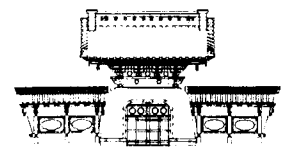
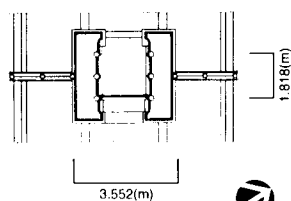
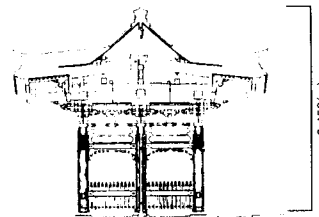
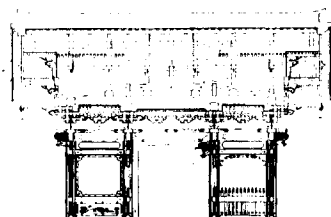
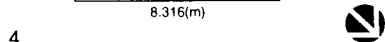
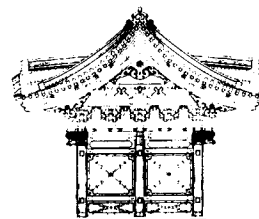
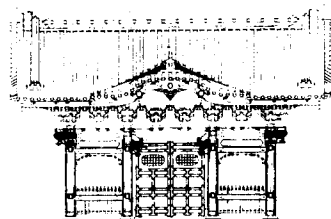
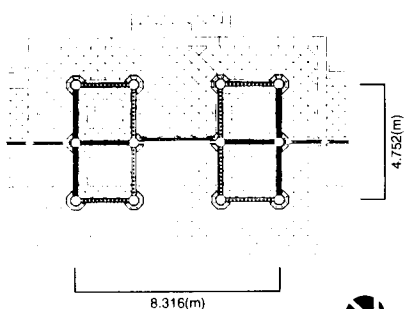
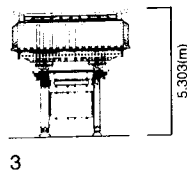
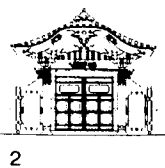
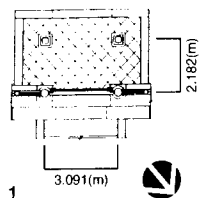

SCALE 1:200

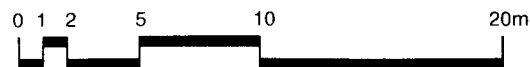

Karamon

1 Plan

2 Elevation(front)

3 Elevation(side)

Yashamon

4 Plan

5 Elevation(front)

6 Elevation(side)

7 Section(front)

8 Section(side)

Kôkamon

9 Plan

10 Elevation(front)

11 Elevation(side)

# APPENDIX 6

## CHRONOLOGICAL TABLE OF NIKKO'S HISTORY IN RELATION TO THE NOMINATED PROPERTY

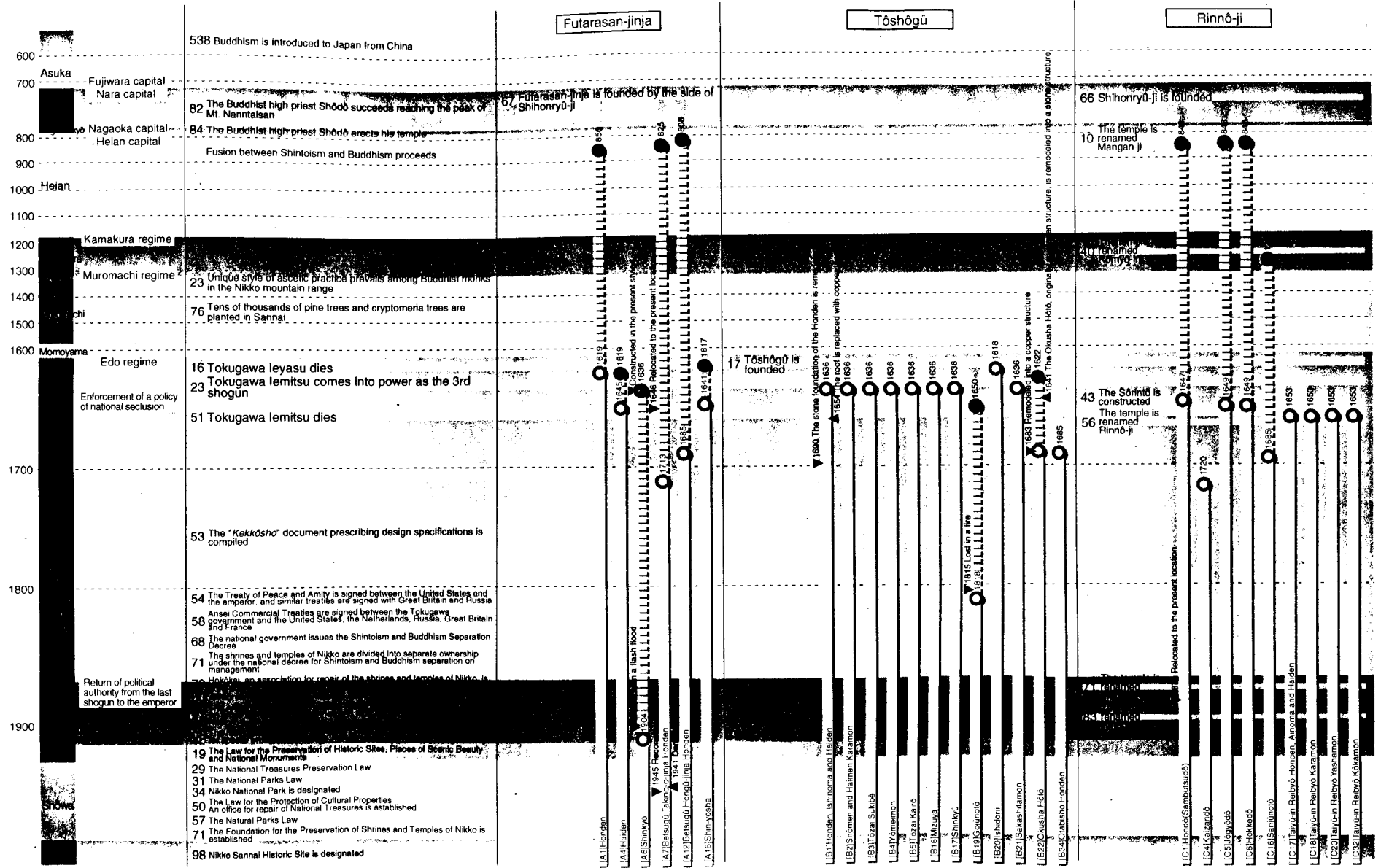







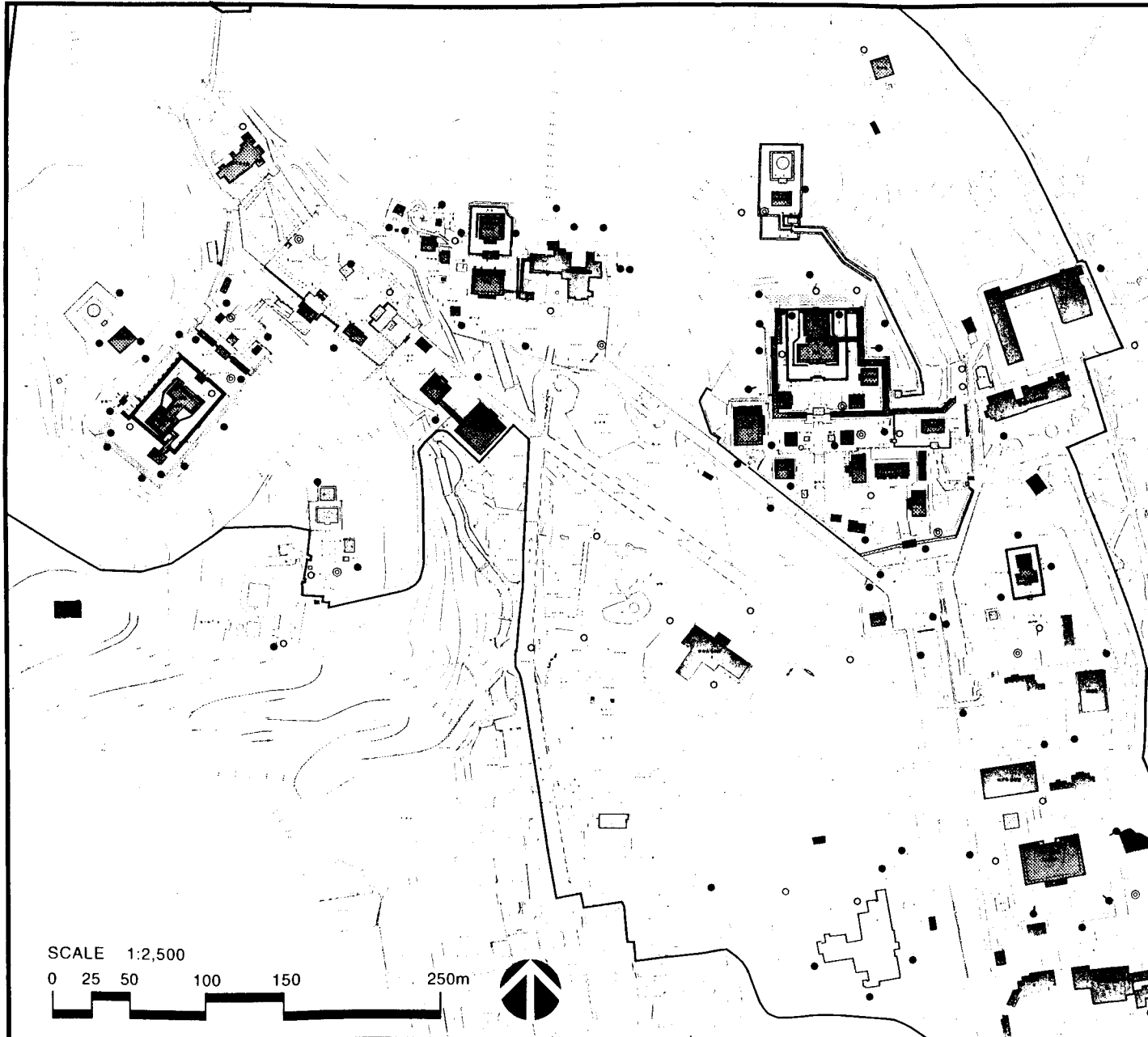





# APPENDIX 7-1

## PLAN INDICATING LOCATIONS OF FIRE PREVENTION SYSTEMS

The Plan of Fire Prevention System



-  Building equipped with automatic fire alarm system
-  Hydrant
-  Underground hydrant
-  Fire extinguisher
-  Water jet
-  Electric pump
-  Drencher system
-  Cistern
-  Building equipped with lighting conductors
-  Lighting conductor (on a tree)
-  Lighting conductor
  
-  Building designated as National Treasure or Important Cultural Property
-  Nominated property

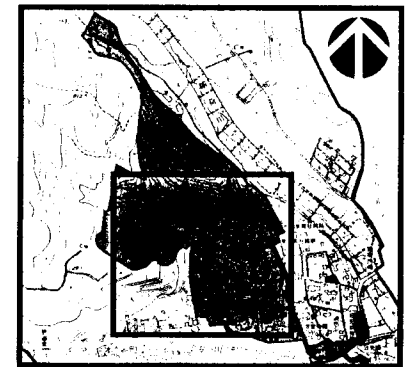







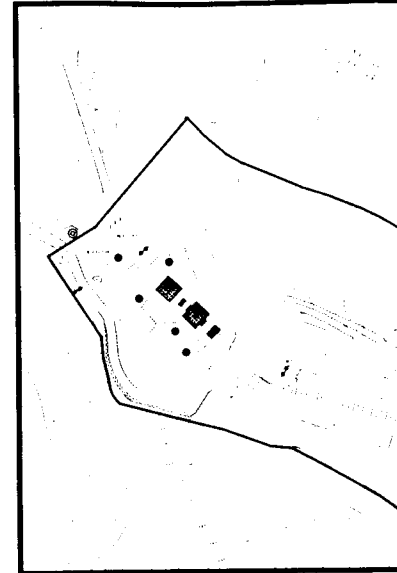
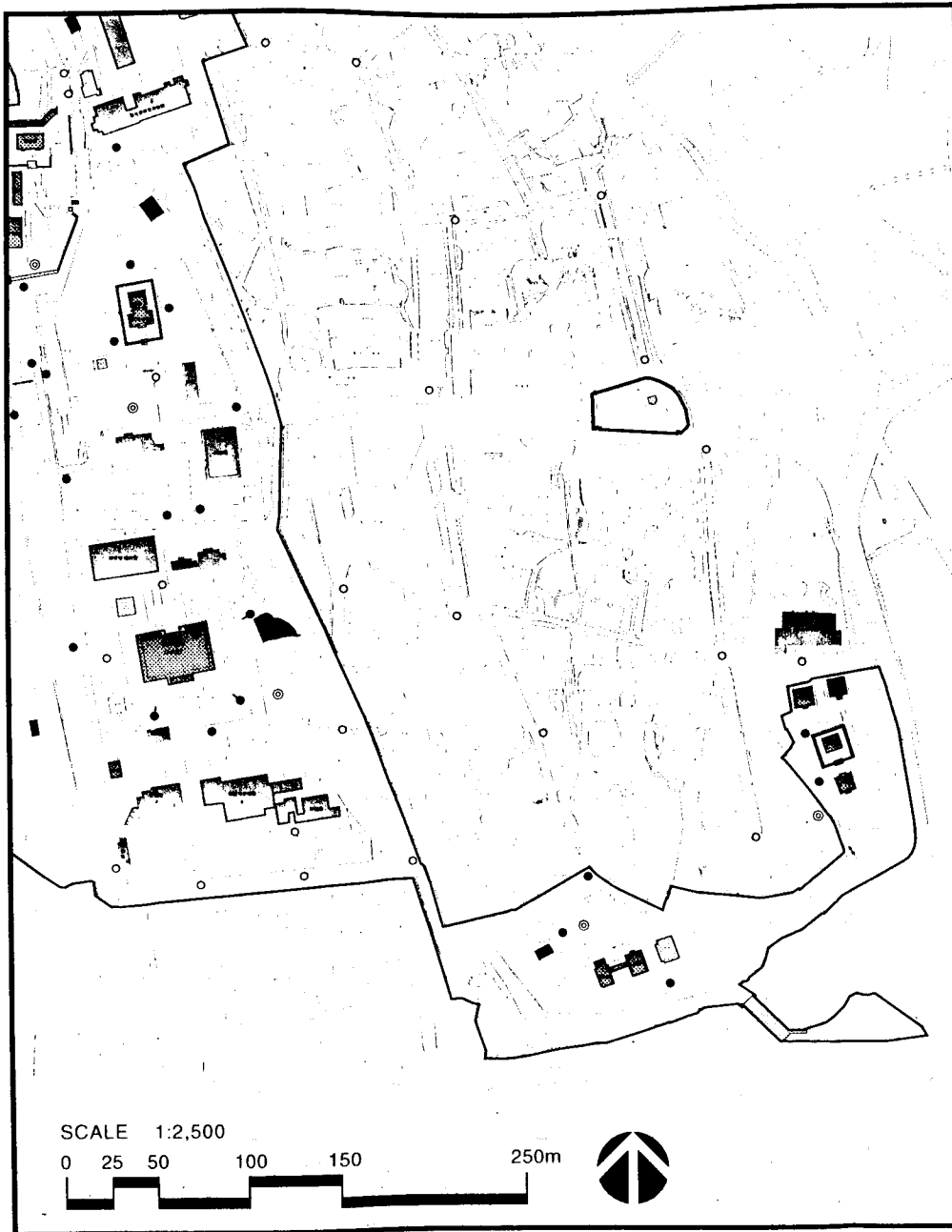





## APPENDIX 7-2

### PLANS INDICATING LOCATIONS OF FIRE PREVENTION SYSTEMS

The Plan of Fire Prevention System



-  Building equipped with automatic fire alarm system
-  Hydrant
-  Underground hydrant
-  Fire extinguisher
-  Water jet
-  Electric pump
-  Drencher system
-  Cistern
-  Building equipped with lighting conductors
-  Lighting conductor (on a tree)
-  Lighting conductor
  
-  Building designated as National Treasure or Important Cultural Property
-  Nominated property

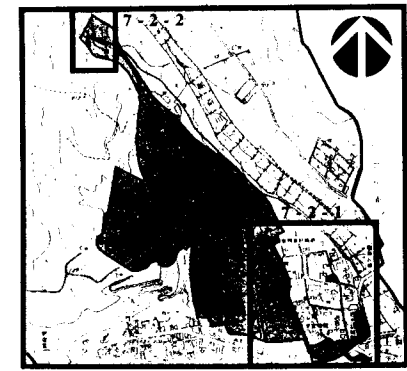



# APPENDIX 8-1

## MAP INDICATING THE ZONES OF LEGAL PROTECTION

Designations under the Law for the Protection of Cultural Properties

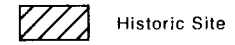

Historic Site

Designations under the Natural Parks Law

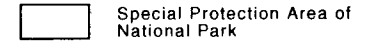

Special Protection Area of National Park

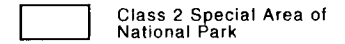

Class 2 Special Area of National Park

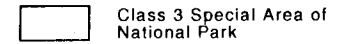

Class 3 Special Area of National Park



Ordinary Area of National Park

Designations under the City Planning Law

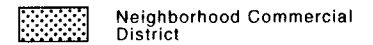

Neighborhood Commercial District



Commercial District

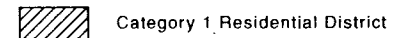

Category 1 Residential District

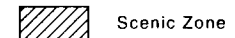

Scenic Zone

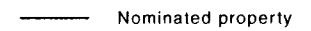

Nominated property

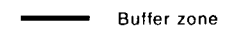

Buffer zone

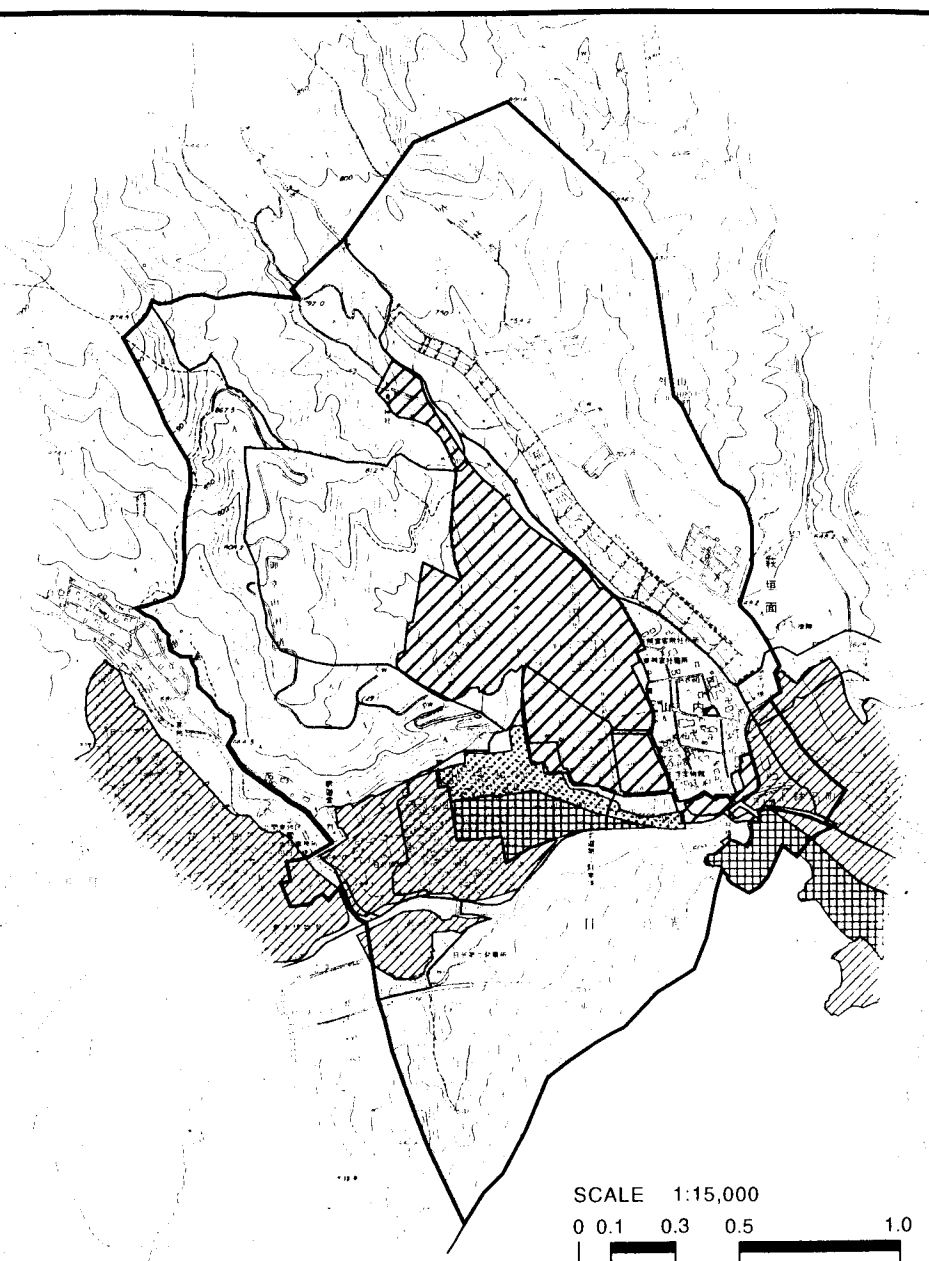

SCALE 1:15,000

0 0.1 0.3 0.5 1.0 1.5km



## APPENDIX 8-2

MAP INDICATING THE ZONES OF  
LEGAL PROTECTION

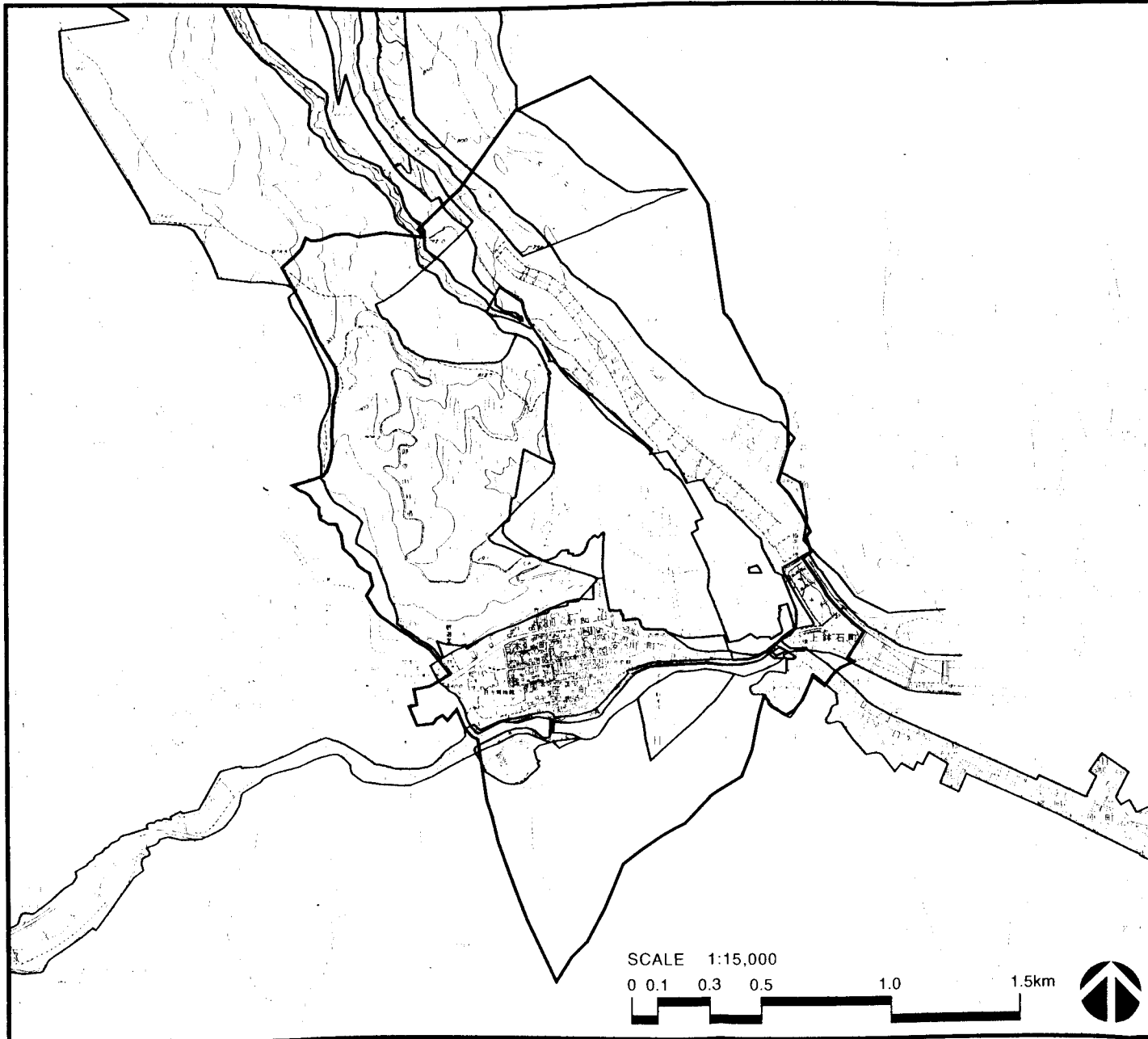

Designations under the Forest Law

 Reserved Forest

Designations under the Sand Control Law

 Sand Control Area

Designations under the River Law

 River Area  
River Conservation Area

Designations under the Nikko Municipal  
Ordinance Concerning Townscape

 Townscape Formation Zone

 Nominated property

 Buffer zone

SCALE 1:15,000

0 0.1 0.3 0.5 1.0 1.5km



# APPENDIX 9









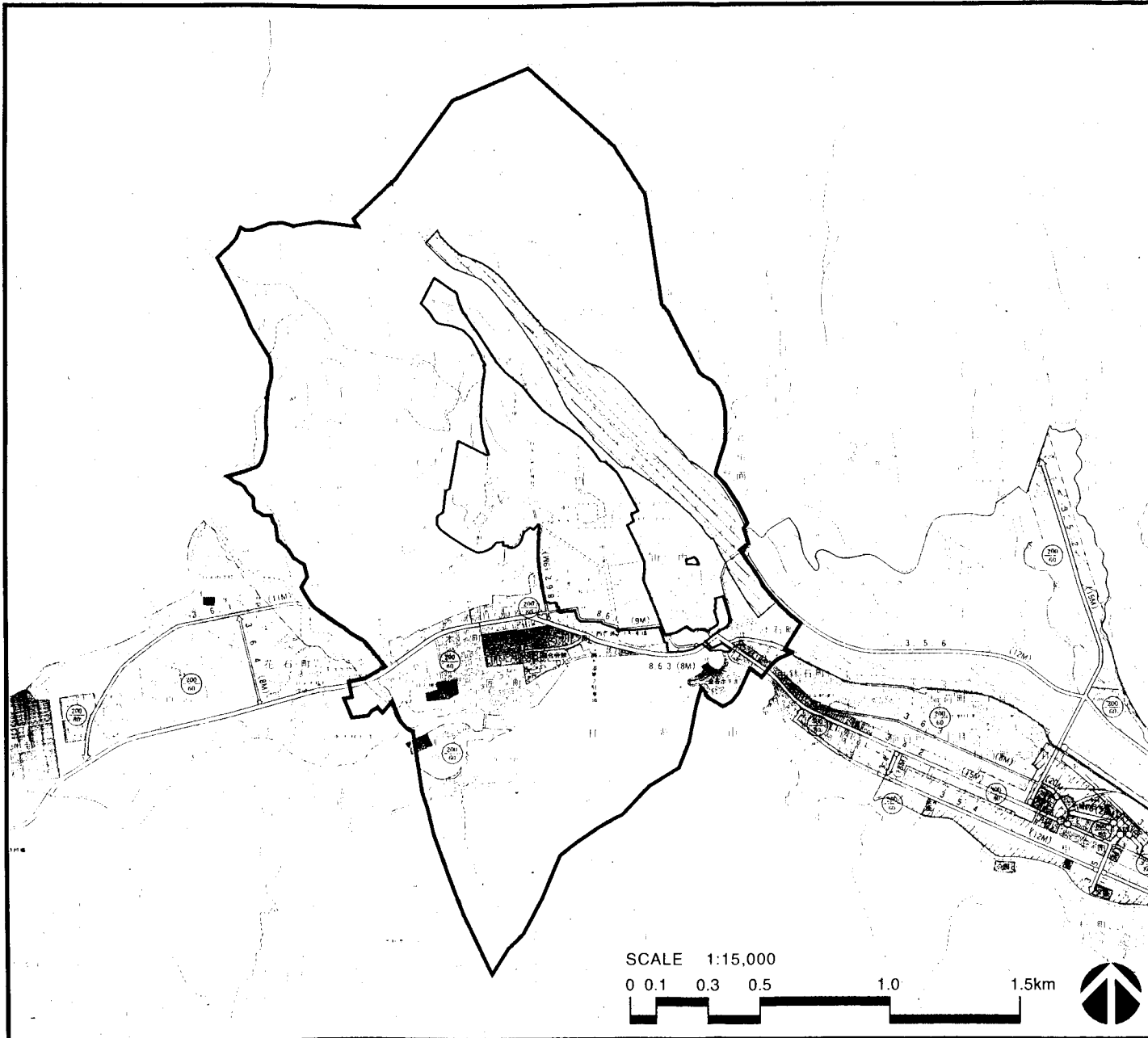



## SUMMARY OF LAWS AND REGULATIONS WHICH CONTROL THE NOMINATED PROPERTY AND THE BUFFER ZONE

Legal instrument	Applicable law / regulation	Summary (purpose)	Procedure required	Restriction on architectural actions			Penalty
Historic Site  ※ See Additional Reference Materials for more details.	Law for the Protection of Cultural Properties	Changes of the existing state are regulated.	Permission	Any person who intends to newly construct, enlarge, remodel or remove a building, to erect or remove a structure to change the land configuration or to cut trees or bamboo shall obtain prior permission before he / she starts the action.			Imprisonment with labor, imprisonment without labor or fine
National Parks (Special Protection Area, Class 2 Special Area, Class 3 Special Area, Ordinary Area)  ※ See Additional Reference Materials for more details.	Natural Parks Law	Regulations for protection and facilities for utilization are planned for the purpose of conserving areas of outstanding natural scenic beauty.	Permission	Special Protection Area	No buildings are permitted.		Imprisonment or fine
				Class 2 Special Area	No buildings higher than 13 m are permitted. No construction larger than 2,000 m <sup>2</sup> is permitted. Construction methods are regulated.	Building coverage is regulated, depending upon the building area. (A limit of 10 %, 15% or 20 % is imposed.)	
			Class 3 Special Area		Building coverage must be 20 % or lower.		
			Notification	Ordinary Area	Buildings should be 25 m high or lower. Building coverage should be 30 % or lower. Instructions regarding construction methods may be given.		
Reserved Forest	Forest Law	Necessary regulations are set to conserve and create sound natural environments and to maintain and improve the various functions of forests for public interests.	Permission	No cutting of standing trees, no excavation of stones or roots or no alteration to the existing land configuration shall be permitted unless such action does not interfere with the purpose of the reserved forest concerned.			Imprisonment or fine
Land Use District (Neighborhood Commercial District, Commercial District, Category 1 Residential District)	City Planning Law	Necessary regulations on land use, floor-area ratio, building coverage, building height, etc. are set to form a sound living environment in urbanized areas and to encourage human activities there through adequate arrangement of areas for different purposes.	Confirmation		Building coverage limit	Floor-area ratio limit	Imprisonment or fine
				Neighborhood Commercial District	80 %	300 %	
				Commercial District	80 %	200 %	
				Category 1 Residential District	60 %	200 %	
Scenic Zone	City Planning Law; Tochigi Prefecture Scenic Zone Ordinance	Necessary regulations on architectural actions and other similar activities are set to maintain the existing scenic beauty.	Permission	No buildings higher than 15 m are permitted. Building coverage must be 40 % or lower. The building must be set back at least 2 m from the street and 1 m from adjacent properties.			Fine
Erosion Control Area	Sand Control Law; Tochigi Prefecture Regulations for the Management of Erosion Control Areas	Restrictions on certain activities are set for the sake of water conservation and sand erosion control.	Permission	Any person who intends to newly construct, remodel or remove a structure shall obtain prior permission before he / she starts the action.			Imprisonment with labor, imprisonment without labor or fine
River Area (River Conservation Area)	River Law	Necessary restrictions on certain activities relating to rivers are set to contribute to the preservation and development of the land by maintaining public safety and promoting public welfare.	Permission	Any person who intends to newly construct, remodel or remove a structure shall obtain prior permission before he / she starts the action.			Imprisonment or fine
Townscape Formation Zone ※ See Additional Reference Materials for more details	Nikko Municipal Ordinance Concerning Townscape		Notification	Buildings should be 15 m high or lower. Walls, hedges and fences should be 2 m high or lower. Buildings should be set back at least 1 m from the street.			--

# APPENDIX 10

MAP OF THE AREA RELEVANT TO AGREED PLANS RELATED TO THE NOMINATED PROPERTY



-  Category 1 Exclusively Medium-high Residential District
-  Category 1 Residential District
-  Neighborhood Commercial District
-  Commercial District
-  Quasi-industrial District
-  Industrial District
-  City Park
-  Scenic Zone
-  Land Readjustment Project Area
-  Area where construction work for sand erosion control is planned
-  Nominated property
-  Buffer zone

# APPENDIX 11-a-1

## CHRONOLOGICAL TABLE OF CONSERVATION WORK

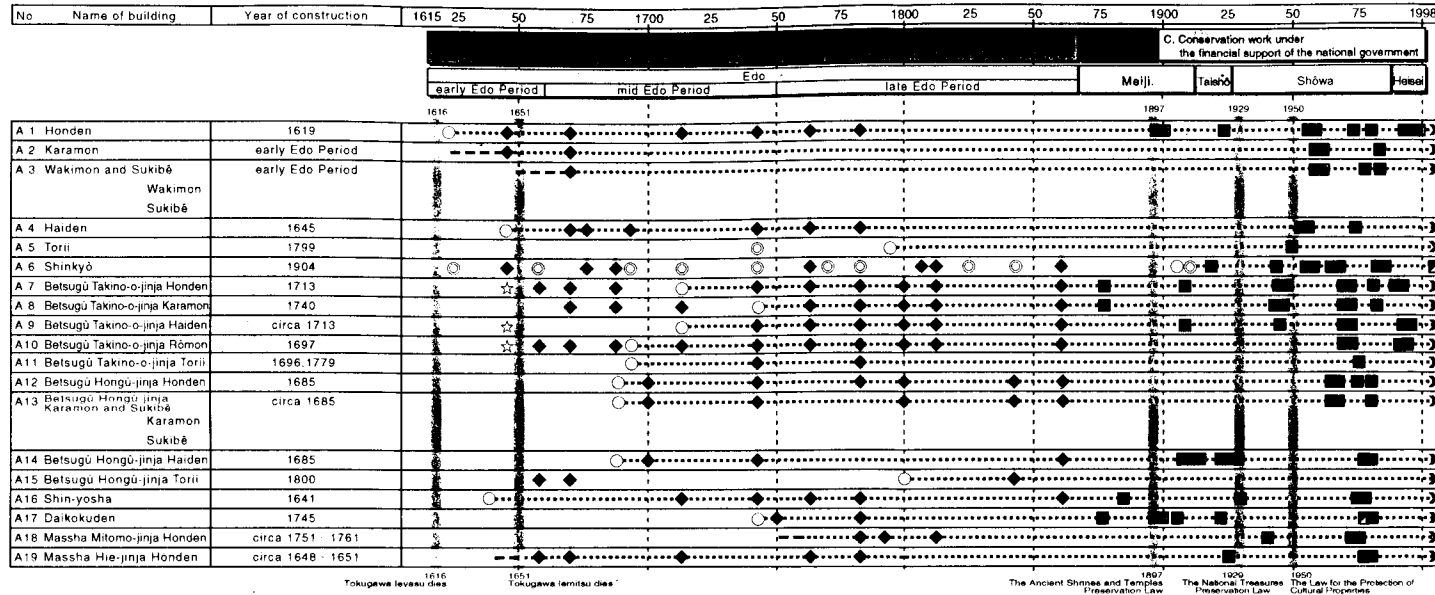

### A: Futarasan-jinja

- Construction
- ⊙ Reconstruction
- ☆ Relocation

### Notes:

- indicates that the specific year of construction is unknown
- ..... indicates that the building is in the present location and style

### A. Conservation work under the Tokugawa government

- ◆ Repair (confirmed)
- ◇ Repair (alleged)

### B. Conservation work after the Meiji Period

- Partial repair by Hokōkai
- Roofing repair
- Roofing repair by Hokōkai

### C. Conservation work under the financial support of the national government

- Repair with dismantlement
- ☑ Repair with partial dismantlement
- Partial repair
- Roofing repair
- Painting repair

\*See APPENDIX 11-b-1 for detailed information about conservation work conducted under the financial support of the national government





Year of completion	Name of building	Type of conservation work	Law	
1899	Honden[A1]	roofing and partial repair	1897 The Ancient Shrines and Temples Preservation Law	
1902	Daikokuden[A17]	painting and partial repair		
1905	Daikokuden[A17]	roofing repair		
1906	Shinkyō[A6]	reconstruction		
1908	Betsugū Takino-o-jinja Honden[A7]	partial repair		
	Betsugū Takino-o-jinja Haiden[A9]	partial repair		
1910	Betsugū Hongū-jinja Haiden[A14]	roofing, painting and partial repair		
1918	Shinkyō[A6]	painting repair		
1922	Daikokuden[A17]	roofing repair		
1923	Honden[A1]	painting repair		
	Betsugū Hongū-jinja Haiden[A14]	roofing, painting and partial repair		
1926	Massha Hie-jinja Honden[A19]	painting repair		1929 The National Treasures Preservation Law
1929	Shin-yosha[A16]	partial repair		
1942	Massha Mitomo-jinja Honden[A18]	roofing repair		
1944	Shinkyō[A6]	partial repair		
1945	Betsugū Takino-o-jinja Honden[A7]	repair with dismantlement and painting repair		
	Betsugū Takino-o-jinja Karamon[A8]	roofing and painting repair		
	Betsugū Takino-o-jinja Haiden[A9]	roofing repair		
1950	Torii[A5]	partial repair	1950 The Law for the Protection of Cultural Properties	
1954	Haiden[A4]	painting and partial repair		
1956	Shinkyō[A6]	repair with dismantlement and painting repair		
1957	Honden[A1]	painting and partial repair		
1959	Karamon[A2]	painting and partial repair		
	Wakimon and Sukibē[A3]	painting and partial repair		
1966	Betsugū Hongū-jinja Honden[A12]	painting and partial repair		
1967	Betsugū Hongū-jinja Karamon and Sukibē[A13]	painting and partial repair		
1968	Shinkyō[A6]	painting and partial repair		
1970	Betsugū Takino-o-jinja Honden[A7]	painting and partial repair		
1971	Betsugū Takino-o-jinja Karamon[A8]	painting and partial repair		
1972	Betsugū Takino-o-jinja Haiden[A9]	painting and partial repair		
	Betsugū Takino-o-jinja Rōmon[A10]	painting and partial repair		
1974	Honden[A1]	painting repair		
	Haiden[A4]	painting repair		
	Betsugū Hongū-jinja Honden[A12]	painting repair		
	Massha Mitomo-jinja Honden[A18]	painting and partial repair		
1975	Betsugū Takino-o-jinja Torii[A11]	repair with dismantlement		
1978	Shin-yosha[A16]	painting and partial repair		
	Daikokuden[A17]	repair with partial dismantlement and painting repair		
	Massha Hie-jinja Honden[A19]	painting and partial repair		
1979	Wakimon and Sukibē[A3]	painting repair		
	Betsugū Takino-o-jinja Honden[A7]	painting repair		
1980	Honden[A1]	painting repair		
	Betsugū Hongū-jinja Honden[A12]	painting repair		
	Betsugū Hongū-jinja Karamon and Sukibē[A13]	painting repair		
	Betsugū Hongū-jinja Haiden[A14]	painting and partial repair		
1981	Betsugū Takino-o-jinja Karamon[A8]	painting repair		
1982	Wakimon and Sukibē[A3]	painting repair		
1983	Karamon[A2]	painting repair		
	Shinkyō[A6]	painting and partial repair		
1990	Betsugū Takino-o-jinja Honden[A7]	painting and partial repair		
1992	Betsugū Takino-o-jinja Rōmon[A10]	painting and partial repair		
1995	Betsugū Takino-o-jinja Haiden[A9]	painting and partial repair		
1996	Honden[A1]	roofing, painting and partial repair		
under way	Shinkyō[A6]	repair with partial dismantlement		
planned	Wakimon and Sukibē[A3]	partial repair		

## APPENDIX II-B-1

### CHRONOLOGICAL TABLE OF CONSERVATION WORK

Conservation Work under the Financial  
Support of the National Government

A: Futarasan-jinja



CHRONOLOGICAL TABLE OF  
CONSERVATION WORKConservation Work under the Financial  
Support of the National Government

B:Tôshôgû

Year of completion	Name of building	Type of conservation work	Law
1900	Okusha Haiden[B25]	painting and partial repair	1897 The Ancient Shrines and Temples Preservation Law
1901	Otabisho Shinsenjo[B36]	roofing and partial repair	
1902	Shôrô[B9] Korô[B10]	roofing, painting and partial repair	
1903	Watarirô[B20-(5)]	roofing, painting and partial repair	
1904	Honjido[B11]	repair with dismantlement and roofing and painting repair	
1905	Kyôzô[B12]	painting and partial repair	
1906	Kamishamusho[B6] Omotemon[B18]	roofing, painting and partial repair	
1907	Uchibansho[B20-(8)]	roofing, painting and partial repair	
1908	Honden[B1] Ishinoma[B1] Haiden[B1] Tôzai Kairô[B5] Shin-yosha[B8]	roofing, painting and partial repair	
1909	Mizuya[B16]	roofing, painting and partial repair	
1910	Tôzai Sukibê[B3]	roofing, painting and partial repair	
1911	Kaguraden[B7] Shimojinko[B15] Shinkyû[B17] Shôsha[B20-(1)] Tôdaihoya[B20-(2)] Tôdaihoya[B20-(3)] Sakashitamono[B21]	roofing, painting and partial repair	
1912	Omotemon[B18]	roofing and painting repair	
1915	Shômen and Haimen Karamon[B2] Yômeimon[B4] Kamishamusho[B6]	roofing, painting and partial repair	
1918	Kamijinko[B13] Nakajinko[B14] Shimojinko[B15]	roofing, painting and partial repair	
1919	Gojûnotô[B19] Sakashitamono[B21]	roofing, painting and partial repair	
1922	Saijô[B20-(9)]	painting and partial repair	
1923	Tôzai Kairô[B5] Honjido[B11] Shinkyû[B17]	roofing, painting and partial repair	
1933	Kariden Honden, Ainoma and Haiden[B29] Kariden Karamon[B30] Kariden Wakimon and Sukibê[B31]	roofing, painting and partial repair	
1936	Honden[B1] Shômen and Haimen Karamon[B2] Shin-yosha[B8]	partial repair	
1941	Yômeimon[B4] Okusha Haiden[B25]	painting and partial repair	
1947	Omotemon[B18]	painting repair	
1951	Mizuya[B16]	painting and partial repair	
1952	Kamishamusho[B6]	partial repair	
1954	Hijûmon and Dôitabê[B20-(7)] Kariden Shôrô[B33] Mizuya[B16] Shinkyû[B17] Omotemon[B18]	repair with dismantlement roofing and painting repair	
1955	Ishinoma[B1]	painting repair	
1957	Honden[B1] Tôzai Kairô[B5]	painting and partial repair	
1958	Haiden[B1]	painting and partial repair	
1960	Shômen and Haimen Karamon[B2] Tôzai Sukibê[B3] Kaguraden[B7]	painting and partial repair	1950 The Law for the Protection of Cultural Properties
1961	Kariden Shôrô[B33]	painting and partial repair	
1962	Nakajinko[B14] Watarirô[B20-(5)]	painting and partial repair	
1963	Kamijinko[B13]	roofing and partial repair	
1964	Shimojinko[B15] Kariden Wakimon and Sukibê[B31]	painting and partial repair	
1965	Otabisho Haiden[B35]	painting and partial repair	

Year of completion	Name of building	Type of conservation work	Law
1965	Otabisho Shinsenjo[B36]	roofing and partial repair	
1966	Otabisho Honden[B34]	painting and partial repair	
1967	Dôkomon and Itabê[B20-(6)] Hijûmon and Dôitabê[B20-(7)] Okusha Karamon[B23] Okusha Dôjinko[B26] Okusha Torii[B27] Kyûokusha Karamon[B37] Kyûokusha Torii[B38]	painting and partial repair	
1968	Honjido[B11]	repair with dismantlement and roofing and painting repair	
1969	Okusha Haiden[B25]	painting and partial repair	
1972	Yômeimon[B4]	painting and partial repair	
1973	Kyôzô[B12] Sakashitamono[B21]	painting and partial repair	
1974	Honden[B1] Ishinoma[B1] Haiden[B1] Tôzai Kairô[B5] Kaguraden[B7] Shôrô[B9] Korô[B10] Kamijinko[B13] Nakajinko[B14] Shimojinko[B15] Mizuya[B16] Shinkyû[B17] Omotemon[B18] Saijô[B20-(9)]	painting repair	
1975	Honden[B1] Tôzai Kairô[B5]	painting repair	
1976	Haiden[B1] Shin-yosha[B8] Higashitayogomono (Sakashitamono)[B20-(10)] Shôsha[B20-(11)]	painting and partial repair	
1977	Shôsha[B20-(11)]	painting and partial repair	
1978	Omotemon[B18] Gojûnotô[B19] Mizuya[B16]	painting repair	
1979	Omotemon[B18] Haiden[B1] Tôzai Sukibê[B3] Kamishamusho[B6] Kaguraden[B7] Kamijinko[B13] Nakajinko[B14] Shinkyû[B17]	painting and partial repair	
1980	Haiden[B1] Tôzai Sukibê[B3] Kamishamusho[B6] Kaguraden[B7] Kamijinko[B13] Nakajinko[B14] Shinkyû[B17] Tôdaihoya[B20-(2)] Tôdaihoya[B20-(3)] Uchibansho[B20-(8)] Otabisho Haiden[B35]	painting and partial repair	
1982	Ishinoma[B1] Kariden Shôrô[B33]	painting repair	
1984	Kariden Honden, Ainoma and Haiden[B29]	roofing repair	
1985	Tôzai Kairô[B5] Shimojinko[B15] Kariden Karamon[B30] Kariden Wakimon and Sukibê[B31] Otabisho Honden[B34]	painting and partial repair	
1986	Ishidori[B20]	painting repair	
1989	Omotemon[B18]	painting repair	
1990	Tôzai Kairô[B5]	painting repair	
1995	Tôzai Kairô[B5] Omotemon[B18] Mizuya[B16] Kariden Karamon[B30] Kariden Wakimon and Sukibê[B31]	painting and partial repair	
1996	Omotemon[B18] Mizuya[B16] Kariden Karamon[B30] Kariden Wakimon and Sukibê[B31] Kamijinko[B13] Tôzai Kairô[B5]	roofing and painting repair	
under way planned	Kamijinko[B13] Tôzai Kairô[B5]	painting and partial repair	

CHRONOLOGICAL TABLE OF CONSERVATION WORK

Conservation Work under the Financial Support of the National Government



C:Rinnō-ji

Year of completion	Name of building	Type of conservation work	Law	
1904	Taiyū-in Reibyō Nitemmon[C27]	thorough repair	1897 The Ancient Shrines and Temples Preservation Law	
1905	Hokkedō[C6]	roofing, painting and partial repair		
	Jōgyōdō Hokkedō Watarirō[C7]	roofing, painting and partial repair		
1906	Jōgyōdō[C5]	roofing, painting and partial repair		
	Taiyū-in Reibyō Niōmon[C31]	painting and partial repair		
1908	Taiyū-in Reibyō Haiden[C17]	roofing and partial repair		
	Taiyū-in Reibyō Mizugaki[C19]	roofing, painting and partial repair		
	Taiyū-in Reibyō Wakimon[C20]	roofing and partial repair		
	Taiyū-in Reibyō Nitemmon[C27]	painting and partial repair		
	Taiyū-in Reibyō Kōkamon[C32]	painting and partial repair		
	Taiyū-in Reibyō Oku-in Inukimon[C35]	roofing and painting repair		
1909	Taiyū-in Reibyō Ainoma[C17]	roofing, painting and partial repair		
	Taiyū-in Reibyō Karamon[C18]	roofing and painting repair		
1911	Taiyū-in Reibyō Honden[C17]	roofing, painting and partial repair		
1912	Taiyū-in Reibyō Yashamon[C23]	partial repair		
1912	Taiyū-in Reibyō Karamon[C18]	painting repair		
1914	Taiyū-in Reibyō Haiden[C17]	painting and partial repair		
	Taiyū-in Reibyō Yashamon[C23]	roofing, painting and partial repair		
1915	Taiyū-in Reibyō Korō[C26]	roofing, painting and partial repair		
	Taiyū-in Reibyō Kōkamon[C32]	painting repair		
1916	Taiyū-in Reibyō Yashamon Saiyū Kairō[C24]	roofing, painting and partial repair		
	Taiyū-in Reibyō Shōrō[C25]	roofing, painting and partial repair		
1918	Taiyū-in Reibyō Niōmon[C31]	painting repair		
1922	Hondō(Sambutsudō)[C1]	painting and partial repair	1929 The National Treasures Preservation Law	
	Taiyū-in Reibyō Nitemmon[C27]	painting repair		
1923	Taiyū-in Reibyō Kōkamon[C32]	painting repair		
1944	Hombō Omotemon[C3]	painting and partial repair		
	Taiyū-in Reibyō Gokūsho[C21]	painting and partial repair		
	Taiyū-in Reibyō Gokūsho Watarirō[C22]	painting and partial repair		
	Taiyū-in Reibyō Saijō[C28]	repair with dismantlement and painting repair		
1951	Taiyū-in Reibyō Gokūsho[C21]	painting and partial repair		1950 The Law for the Protection of Cultural Properties
	Taiyū-in Reibyō Gokūsho Watarirō[C22]	painting and partial repair		
1952	Taiyū-in Reibyō Ainoma[C17]	painting and partial repair		
1953	Taiyū-in Reibyō Honden[C17]	painting and partial repair		
1954	Taiyū-in Reibyō Haiden[C17]	painting and partial repair		
1960	Hondō(Sambutsudō)[C1]	repair with dismantlement and roofing and painting repair		
1961	Hombō Omotemon[C3]	painting and partial repair		
1962	Taiyū-in Reibyō Nitemmon[C27]	painting and partial repair		
1963	Taiyū-in Reibyō Kōkamon[C32]	painting and partial repair		
1965	Taiyū-in Reibyō Saijō[C28]	repair with dismantlement and roofing and painting repair		
1966	Taiyū-in Reibyō Karamon[C18]	painting repair		
	Taiyū-in Reibyō Mizugaki[C19]	painting repair		
1967	Kodamadō[C13]	repair with dismantlement and roofing and painting repair		
	Taiyū-in Reibyō Dōzutsumi Hōzō[C33]	repair with partial dismantlement and painting repair		
1969	Taiyū-in Reibyō Mizugaki[C19]	painting repair		
	Taiyū-in Reibyō Oku-in Inukimon[C35]	painting repair		
1970	Taiyū-in Reibyō Oku-in Haiden[C36]	painting and partial repair		
1973	Hondō(Sambutsudō)[C1]	painting repair		
	Taiyū-in Reibyō Ainoma[C17]	painting repair		
	Taiyū-in Reibyō Karamon[C18]	painting repair		
	Taiyū-in Reibyō Gokūsho[C21]	painting repair		
	Taiyū-in Reibyō Gokūsho Watarirō[C22]	painting repair		
1974	Hombō Omotemon[C3]	painting repair		
	Jōgyōdō[C5]	repair with partial dismantlement and painting repair		
	Taiyū-in Reibyō Honden[C17]	painting repair		
	Taiyū-in Reibyō Haiden[C17]	painting repair		
	Taiyū-in Reibyō Nitemmon[C27]	painting repair		
	Taiyū-in Reibyō Kōkamon[C32]	painting repair		
1976	Jōgyōdō Hokkedō Watarirō[C7]	painting and partial repair		
1979	Hokkedō[C6]	painting and partial repair		
	Taiyū-in Reibyō Honden[C17]	painting repair		
	Taiyū-in Reibyō Ainoma[C17]	painting repair		
	Taiyū-in Reibyō Haiden[C17]	painting repair		
	Taiyū-in Reibyō Nitemmon[C27]	painting repair		

Year of completion	Name of building	Type of conservation work	Law
1980	Hondō(Sambutsudō)[C1]	painting repair	
	Taiyū-in Reibyō Mizugaki[C19]	painting repair	
	Taiyū-in Reibyō Saijō[C28]	painting repair	
	Taiyū-in Reibyō Hōko[C30]	painting and partial repair	
1982	Taiyū-in Reibyō Kōkamon[C32]	painting and partial repair	
1983	Kodamadō[C13]	painting repair	
1984	Taiyū-in Reibyō Karamon[C18]	painting repair	
1985	Taiyū-in Reibyō Mizugaki[C19]	painting repair	
	Taiyū-in Reibyō Gokūsho[C21]	painting and partial repair	
	Taiyū-in Reibyō Gokūsho Watarirō[C22]	painting and partial repair	
	Taiyū-in Reibyō Niōmon[C31]	painting and partial repair	
1990	Jigandō Amidadō[C12]	repair with dismantlement and roofing and painting repair	
	Taiyū-in Reibyō Yashamon[C23]	painting and partial repair	
	Taiyū-in Reibyō Yashamon Saiyū Kairō[C24]	painting and partial repair	
1993	Kalzandō[C4]	roofing, painting and partial repair	
1994	Taiyū-in Reibyō Nitemmon[C27]	painting and partial repair	
1996	Taiyū-in Reibyō Shōrō[C25]	painting and partial repair	
	Taiyū-in Reibyō Mizuya[C29]	roofing, painting and partial repair	
	Taiyū-in Reibyō Oku-in Haiden[C36]	painting repair	
under way	Taiyū-in Reibyō Korō[C26]	painting and partial repair	

# APPENDIX 12-1

PLAN INDICATING LOCATIONS OF THE BUILDINGS FOR WHICH CONSERVATION WORK HAS BEEN COMPLETED



-  Building for which major conservation work\* has been completed
-  Building for which minor conservation work\* has been conducted

Notes: major conservation work includes complete or partial dismantlement of structure members;  
minor conservation work is regular maintenance work such as thorough repair, partial repair, roofing repair and painting repair.

- [B23]Okusha Karamon
- [B24]Okusha Ishitamagaki
- [B25]Okusha Haiden
- [B26]Okusha Dōjinko
- [B27]Okusha Torii

- [C4]Kaizandō
- [C5]Jōgyōdō
- [C6]Hokkedō
- [C7]Jōgyōdō Hokkedō Watarirō
- [C12]Jigendō Amidadō

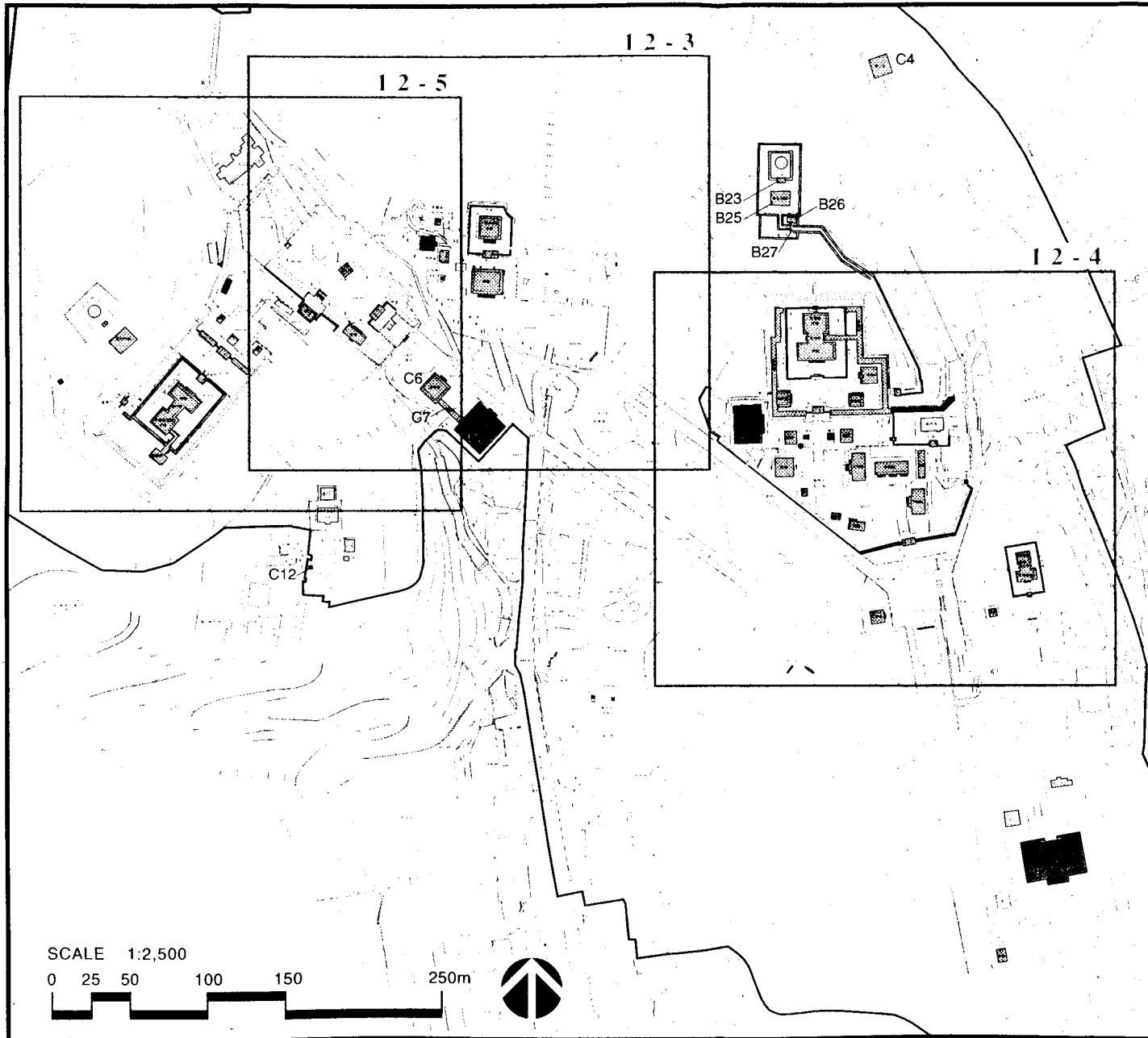
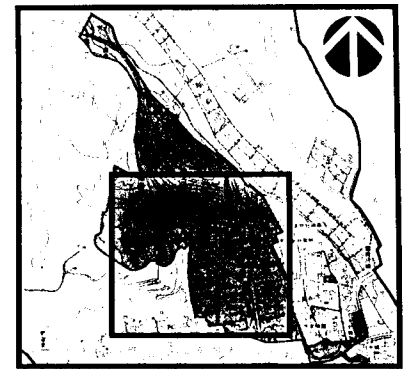

- |   |      |
|---|------|
| [A1]-[A5],[A16]-[A19]   | 12-3 |
| [B1]-[B20],[B-(1)]-[B-(3)],<br>[B-(5)]-[B-(10)],[B21],[B29]-[B33],<br>[B37]-[B38] | 12-4 |
| [C17]-[C33],[C35]-[C36]   | 12-5 |

-  Building designated as National Treasure or Important Cultural Property
-  Nominated property



## APPENDIX 12-2

PLANS INDICATING LOCATIONS OF THE BUILDINGS FOR WHICH CONSERVATION WORK HAS BEEN COMPLETED



-  Building for which major conservation work\* has been completed
-  Building for which minor conservation work\* has been conducted

Notes: major conservation work includes complete or partial dismantlement of structure members; minor conservation work is regular maintenance work such as thorough repair, partial repair, roofing repair and painting repair.

- [A6]Shinkyô
- [A7]Betsugû Takino-o-jinja Honden
- [A8]Betsugû Takino-o-jinja Karamon
- [A9]Betsugû Takino-o-jinja Haiden
- [A10]Betsugû Takino-o-jinja Rômon
- [A11]Betsugû Takino-o-jinja Torii
- [A12]Betsugû Hongû-jinja Honden
- [A13]Betsugû Hongû-jinja Karamon
- [A13]Betsugû Hongû-jinja Sukibê
- [A14]Betsugû Hongû-jinja Haiden

- [B34]Otabisho Honden
- [B35]Otabisho Haiden
- [B36]Otabisho Shinsenjo
- [B36-(1)]Watarirô

- [C1]Homdô(Sambutsudô)
- [C3]Honbô Omotemon
- [C13]Kodamadô

-  Building designated as National Treasure or Important Cultural Property
-  Nominated property

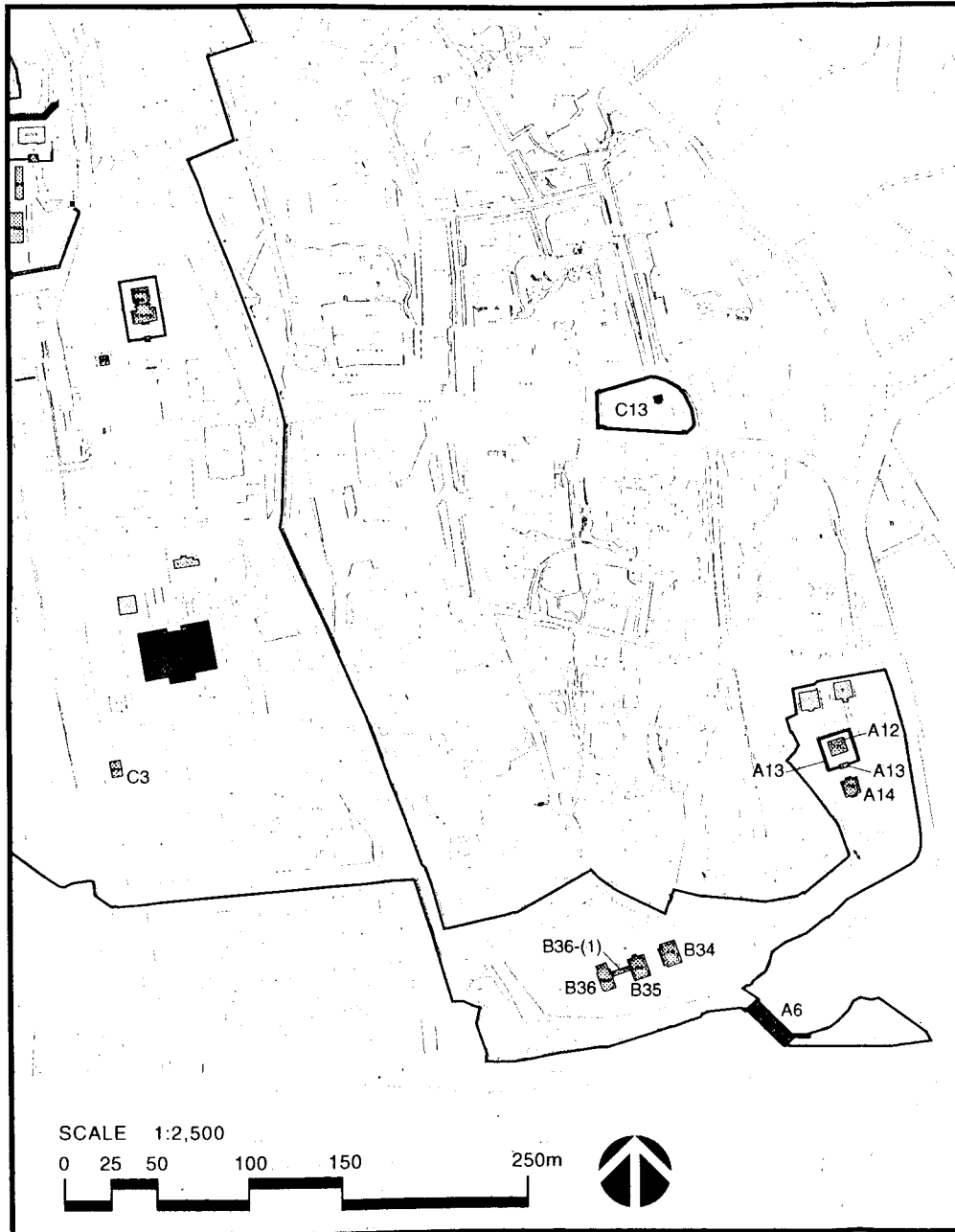

12-2-1

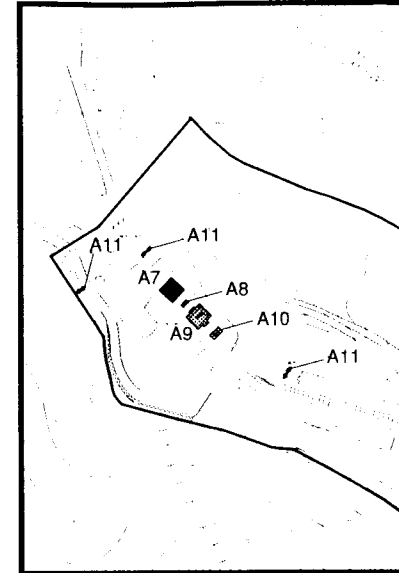

12-2-2

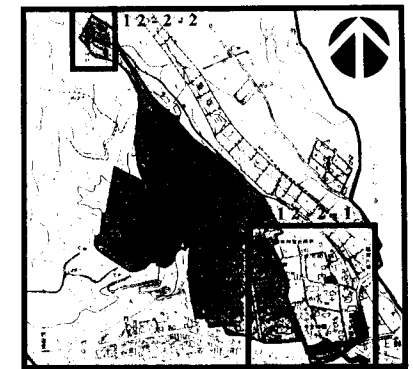



JAPAN/NIKKO

# APPENDIX 12-3



PLAN INDICATING LOCATIONS OF THE BUILDINGS FOR WHICH CONSERVATION WORK HAS BEEN COMPLETED

A:Futarasan-jinja

-  Building for which major conservation work\* has been completed
-  Building for which minor conservation work\* has been conducted

Notes: major conservation work includes complete or partial dismantlement of structure members;  
 minor conservation work is regular maintenance work such as thorough repair, partial repair, roofing repair and painting repair.

- [A1]Honden
- [A2]Karamon
- [A3]Wakimon
- [A3]Sukibé
- [A4]Haiden
- [A5]Torii
- [A16]Shin-yosha
- [A17]Daikokuden
- [A18]Massha Mitomo-jinja Honden
- [A19]Massha Hie-jinja Honden

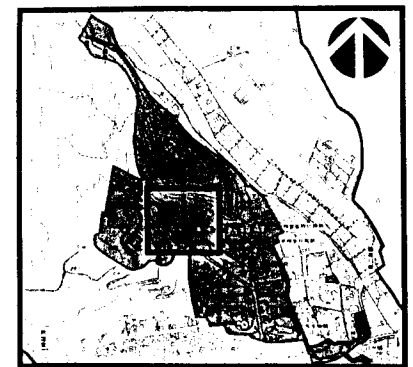
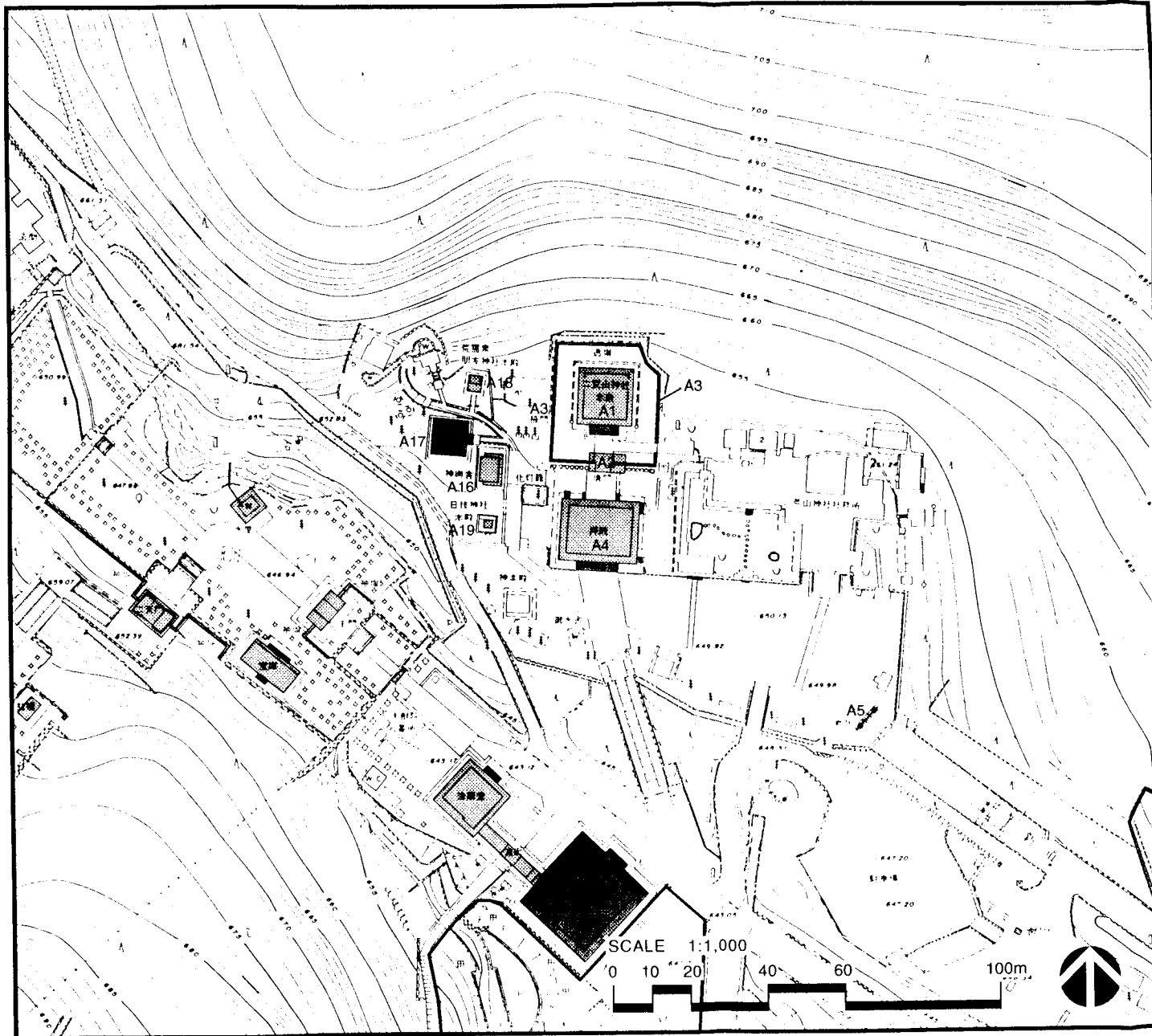

-  Building designated as National Treasure or Important Cultural Property
-  Nominated property



# APPENDIX 12-4

PLAN INDICATING LOCATIONS OF THE BUILDINGS FOR WHICH CONSERVATION WORK HAS BEEN COMPLETED

B: Tōshōgū

-  Building for which major conservation work\* has been completed
-  Building for which minor conservation work\* has been conducted

Notes: major conservation work includes complete or partial dismantlement of structure members; minor conservation work is regular maintenance work such as thorough repair, partial repair, roofing repair and painting repair.

- |                      |                               |
|----------------------|-------------------------------|
| [B1] Honden          | [B20] Ishidorii               |
| [B1] Ishitoma        | [B20-(1)] Shōsha              |
| [B1] Haiden          | [B20-(2)] Tōdaihoya           |
| [B2] Shōmen Karamon  | [B20-(3)] Tōdaihoya           |
| [B2] Haimen Karamon  | [B20-(5)] Watarrō             |
| [B3] Tōzai Sukibē    | [B20-(6)] Dōkomon and Itabē   |
| [B4] Yōmeimon        | [B20-(7)] Hijōmon and Dōitabē |
| [B5] Tōzai Kairō     | [B20-(8)] Uchibansho          |
| [B5-(1)] Kugurimon   | [B20-(9)] Saijō               |
| [B6] Kamishamusho    | [B20-(10)] Higashitsūyōgomon  |
| [B7] Kaguraden       | [B21] Sakashitamon (Shakemon) |
| [B8] Shin-yosha      | [B29] Kariden Honden          |
| [B9] Shōrō           | [B29] Kariden Ainoma          |
| [B10] Korō           | [B29] Kariden Haiden          |
| [B11] Honjūdō*       | [B30] Kariden Karamon         |
| [B12] Kyōzō*         | [B31] Kariden Wakimon         |
| [B13] Kamijinko      | [B31] Kariden Sukibē          |
| [B14] Nakajinko      | [B33] Kariden Shōrō           |
| [B15] Shimojinko     | [B37] Kyōkusha Karamon        |
| [B16] Mizuya         | [B38] Kyōkusha Torii          |
| [B17] Shinkyū        |                               |
| [B18] Omotemon       |                               |
| [B18-(1)] Sasarakobē |                               |
| [B19] Gojūnotō       |                               |

\* indicates that the building is in the custody of the foundation for the Preservation of Shrines and Temples to Nikko.

 Building designated as National Treasure or Important Cultural Property

 Nominated property

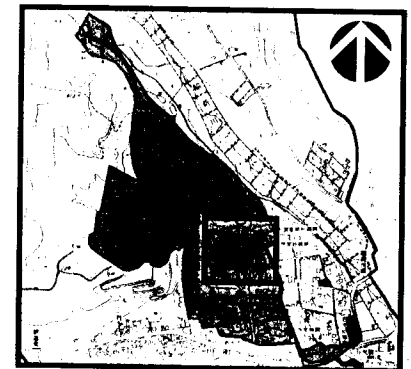

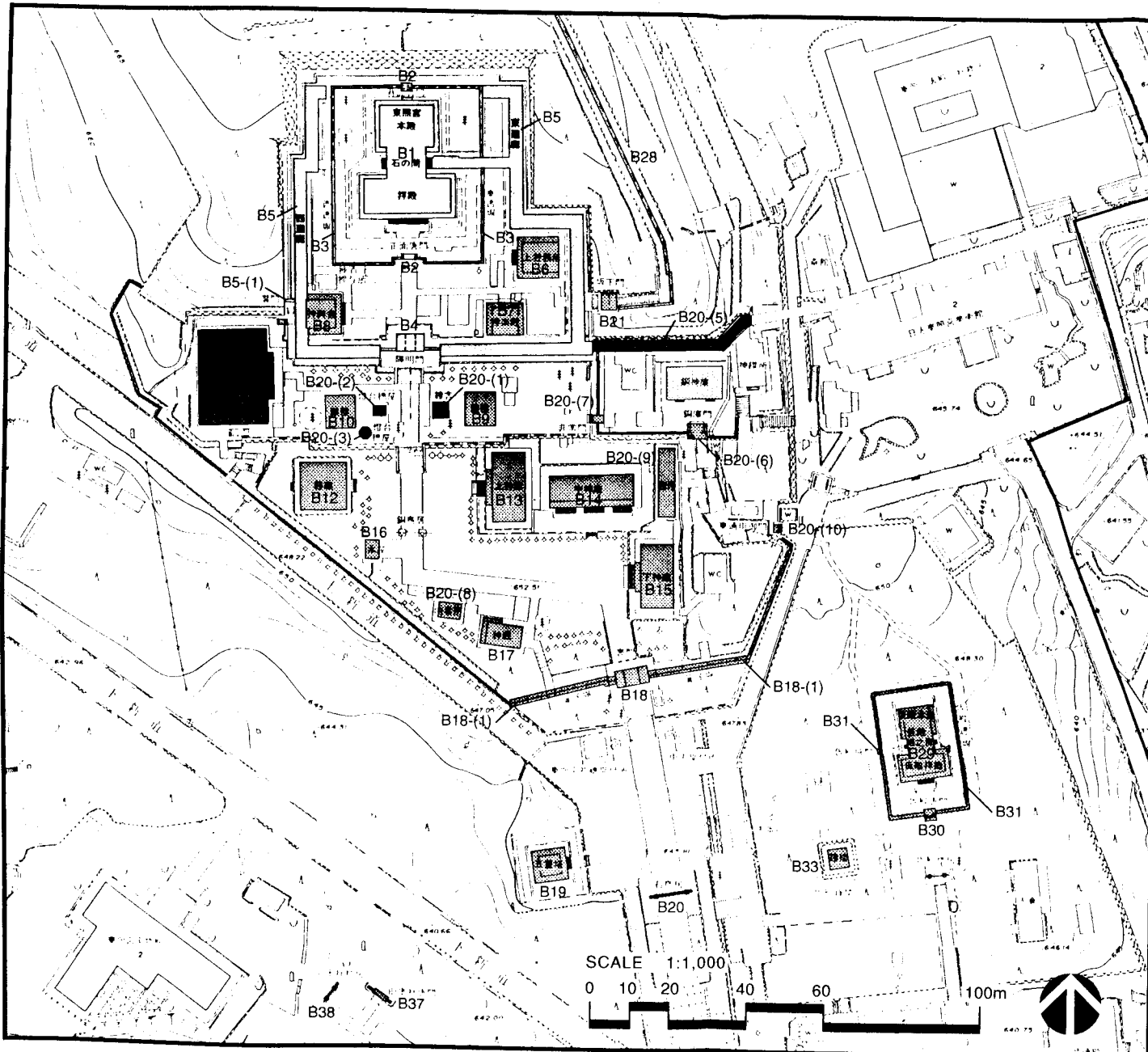
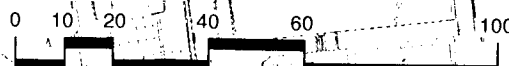

SCALE 1:1,000



# APPENDIX 12-5



PLAN INDICATING LOCATIONS OF THE BUILDINGS FOR WHICH CONSERVATION WORK HAS BEEN COMPLETED

C:Rinnô-ji

-  Building for which major conservation work\* has been completed
-  Building for which minor conservation work\* has been conducted

Notes: major conservation work includes complete or partial dismantlement of structure members;  
minor conservation work is regular maintenance work such as thorough repair, partial repair, roofing repair and painting repair.

- [C17] Taiyû-in Reibyô Honden
- [C17-(1)] Zushi
- [C17] Taiyû-in Reibyô Ainoma
- [C17] Taiyû-in Reibyô Haiden
- [C18] Taiyû-in Reibyô Karamon
- [C19] Taiyû-in Reibyô Mizugaki
- [C20] Taiyû-in Reibyô Wakimon
- [C21] Taiyû-in Reibyô Gokûsho
- [C22] Taiyû-in Reibyô Gokûsho Watarirô
- [C23] Taiyû-in Reibyô Yashamon
- [C24] Taiyû-in Reibyô Yashamon Sayû Kairô
- [C24-(1)] Kugurimon
- [C25] Taiyû-in Reibyô Shôrô
- [C26] Taiyû-in Reibyô Korô
- [C27] Taiyû-in Reibyô Nitemmon
- [C27-(1)] Sayû Sodebê
- [C28] Taiyû-in Reibyô Saijô
- [C29] Taiyû-in Reibyô Mizuya
- [C30] Taiyû-in Reibyô Hôko
- [C31] Taiyû-in Reibyô Niômon
- [C31-(1)] Sayû Sodebê
- [C32] Taiyû-in Reibyô Kôkamon
- [C32-(1)] Sayû Sodebê
- [C33] Taiyû-in Reibyô Dôzutsumi Hôzô
- [C35] Taiyû-in Reibyô Oku-in Inukimon
- [C36] Taiyû-in Reibyô Oku-in Haiden

-  Building designated as National Treasure or Important Cultural Property
-  Nominated property

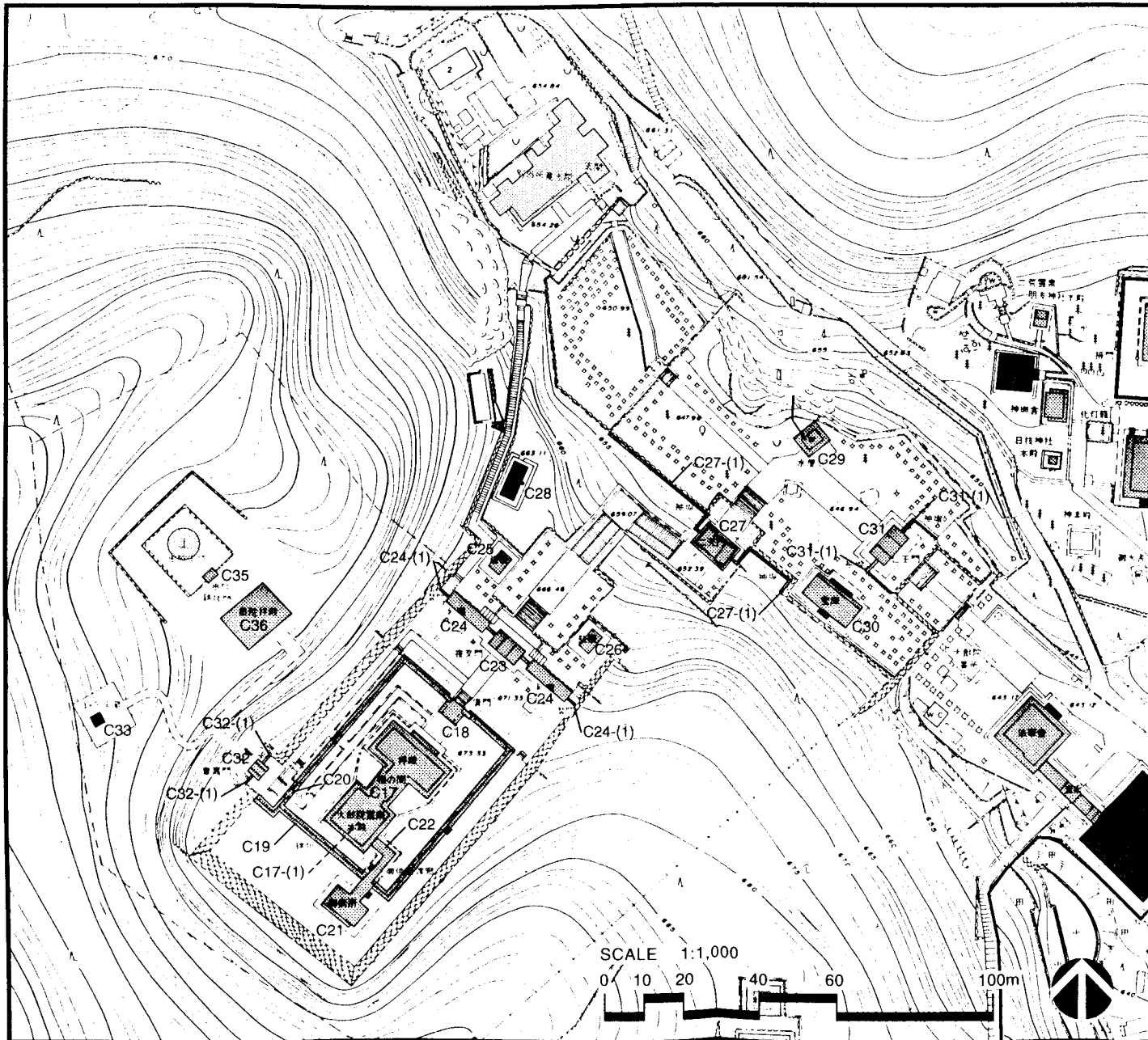
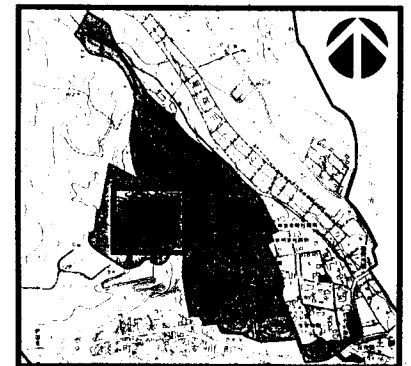

# APPENDIX 13-1

PLAN INDICATING LOCATIONS OF  
SUPPORT FACILITIES AND  
FACILITIES FOR VISITORS

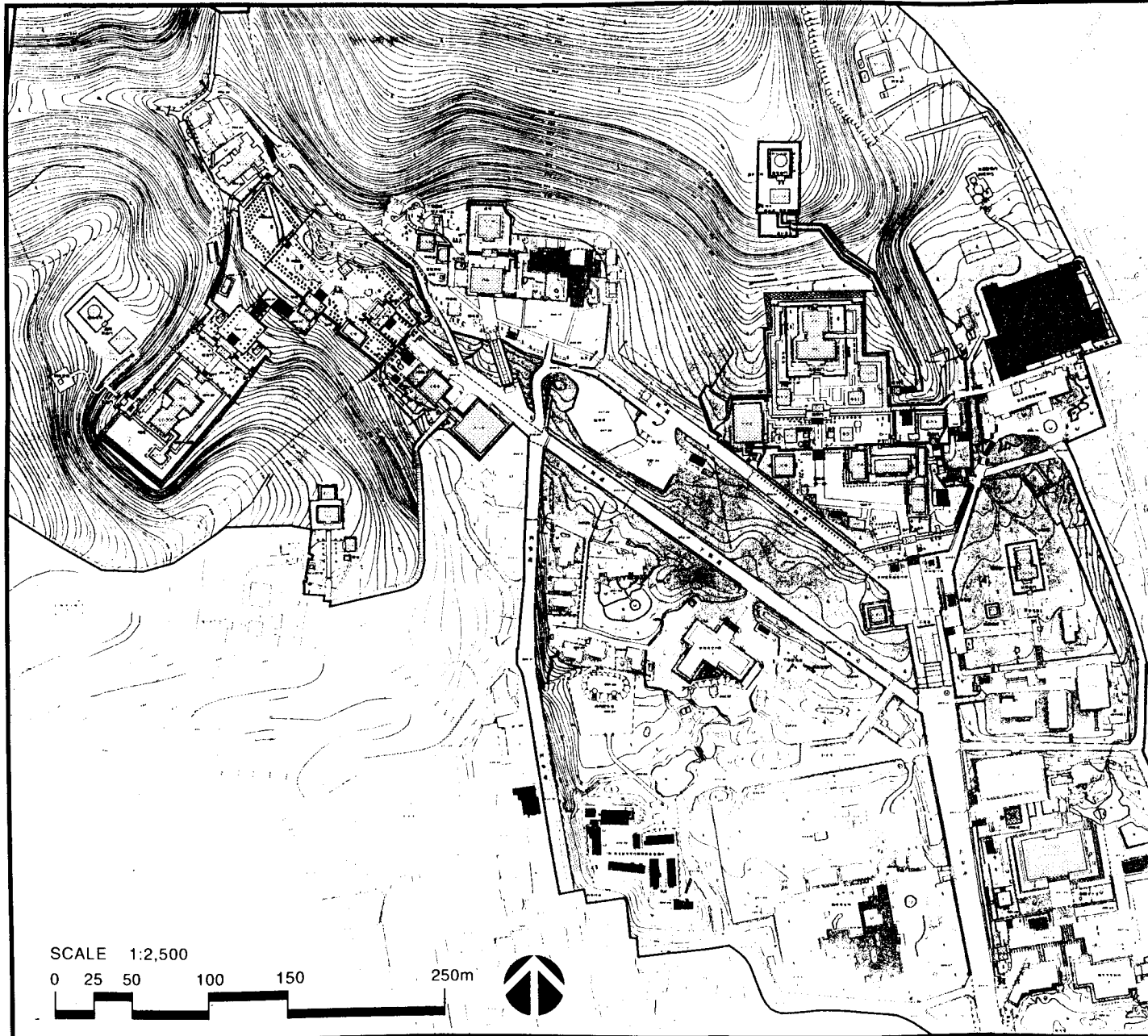

-  Area open to the public
-  Area closed to the public
-  Management building (The Foundation for the Preservation of Shrines and Temples of Nikko)
-  Management building
-  Lavatory
-  Resting facility
-  Parking
-  Treasury and museum
-  Shop
-  Accommodation
  
-  Building designated as National Treasure or Important Cultural Property
-  Nominated property

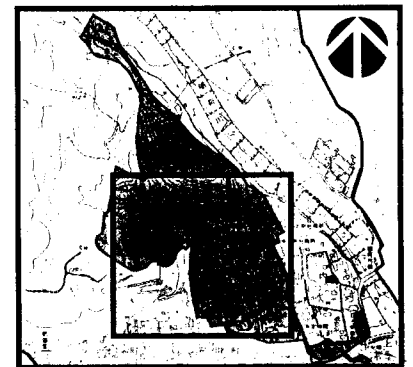



## APPENDIX 13-2



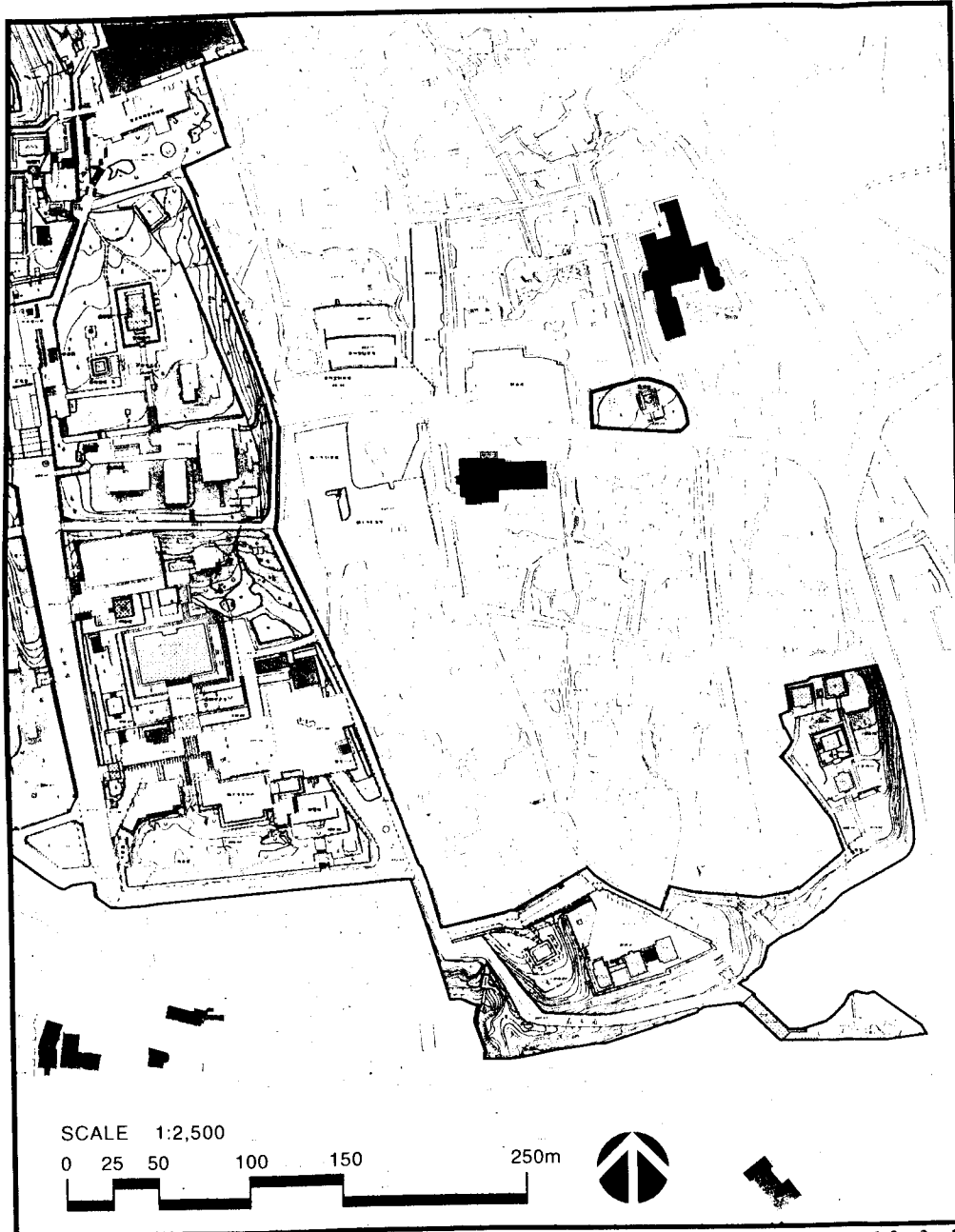



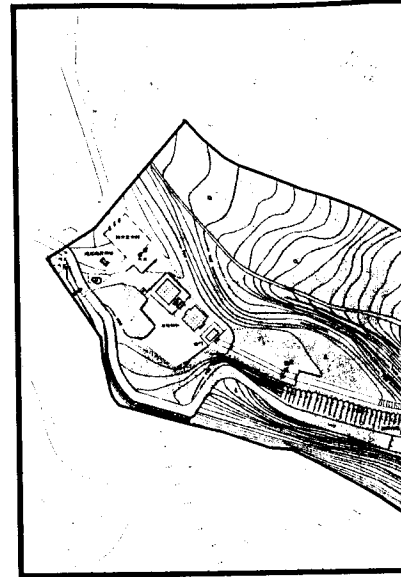





PLANS INDICATING LOCATIONS OF  
SUPPORT FACILITIES AND  
FACILITIES FOR VISITORS



13-2-1



13-2-2

-  Area open to the public
-  Area open to the public (only on special days)
-  Area closed to the public
-  Management building (The Foundation for the Preservation of Shrines and Temples of Nikko)
-  Management building
-  Lavatory
-  Resting facility
-  Parking
-  Treasury and museum
-  Shop
-  Restaurant
-  Accommodation
-  Building designated as National Treasure or Important Cultural Property
-  Nominated property

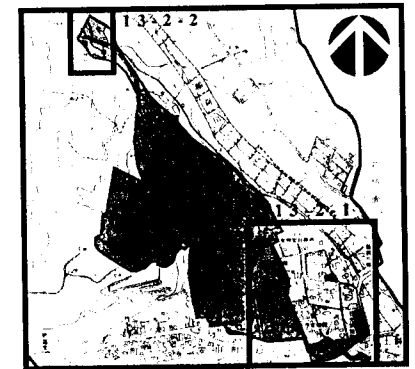

JAPAN / NIKKO





45 Rinnô-ji: the Taiyû-in Reibyô Ainoma. Interior.



**LAW FOR THE PROTECTION OF  
CULTURAL PROPERTIES**

Promulgated on May 30, 1950

Law No.214

AGENCY FOR CULTURAL AFFAIRS  
GOVERNMENT OF JAPAN

## Contents

CHAPTER I	General Provisions (Article 1 — Article 4)	2
CHAPTER II	Deleted (Article 5 — Article 26)	3
CHAPTER III	Tangible Cultural Properties	3
Section 1.	Important Cultural Properties (Article 27 — Article 56)	3
Subsection 1.	Designation (Article 27 — Article 29)	3
Subsection 2.	Custody (Article 30 — Article 34)	4
Subsection 3.	Protection (Article 34-2 — Article 47)	6
Subsection 4.	Opening to the Public (Article 47-2 — Article 53)	11
Subsection 5.	Investigation (Article 54 — Article 55)	13
Subsection 6.	Miscellaneous Provisions (Article 56)	13
Section 2.	Registered Tangible Cultural Properties (Article 56-2 — Article 56-2-11)	14
Section 3.	Tangible Cultural Properties other than Important Cultural Properties and Registered Tangible Cultural Properties (Article 56-2-12)	16
CHAPTER III-2	Intangible Cultural Properties (Article 56-3 — Article 56-9)	16
CHAPTER III-3	Folk-cultural Properties (Article 56-10 — Article 56-21)	18
CHAPTER IV	Buried Cultural Property (Article 57 — Article 68)	20
CHAPTER V	Historic Sites, Places of Scenic Beauty and/or Natural Monuments (Article 69 — Article 83)	24
CHAPTER V-2	Preservation Districts for Groups of Historic Buildings (Article 83-2 — Article 83-6)	30
CHAPTER V-3	Protection of Traditional Techniques for Conservation of Cultural Properties (Article 83-7 — Article 83-12)	31
CHAPTER V-4	The Council for the Protection of Cultural Properties (Article 84 — Article 84-4)	32
CHAPTER VI	Additional Provisions	34
Section 1.	Public Hearings and Protests (Article 85 — Article 85-8)	34
Section 2.	Special Provisions regarding the State (Article 86 — Article 97-5)	36
Section 3.	Local Public Bodies and Boards of Education (Article 98 — Article 105-2)	41
CHAPTER VII	Penal Provisions (Article 106 — Article 112)	45
Supplementary Provisions	(Article 113 — Article 130)	48

## CHAPTER I General Provisions

(Purpose of this Law)

Article 1. The purpose of this Law is to preserve and utilize cultural properties, so that the culture of the Japanese people may be furthered and a contribution be made to the evolution of world culture.

(Definition of Cultural Properties)

Article 2. "Cultural properties" in this Law shall be the following:

- (1) Buildings, pictures, sculptures, applied arts, calligraphic works, classical books, ancient documents, and other tangible cultural products, which possess a high historical and/or artistic value in and for this country (including lands and other objects which are combined with them altogether to embody such value), archaeological specimens and other historical materials of high scientific value (hereinafter referred to as "tangible cultural properties");
  - (2) Art and skill employed in drama, music and applied arts, and other intangible cultural products, which possess a high historical and/or artistic value in and for this country (hereinafter referred to as "intangible cultural properties");
  - (3) Manners and customs related to food, clothing and housing, to occupations, religious faiths, festivals, etc., to folk-entertainments and clothes, implements, houses and other objects used therefor, which are indispensable for the understanding of changes in our people's modes of life (hereinafter referred to as "folk-cultural properties");
  - (4) Shell mounds, ancient tombs, sites of palaces, sites of forts or castles, monumental dwelling houses, and other sites, which possess a high historical and/or scientific value in and for this country; gardens, bridges, gorges, sea-shores, mountains, and other places of scenic beauty, which possess a high value from the point of view of art or visual appreciation in and for this country; and animals (including their habitats, breeding places and summer and winter resorts), plants (including their habitats), and geological features and minerals (including the grounds where peculiar natural phenomena are seen), which possess a high scientific value in and for this country (hereinafter referred to as "monuments");
  - (5) Groups of historic buildings of high value which form a certain antique beauty in combination with their environs (hereinafter referred to as "groups of historic buildings");
2. The term "important cultural properties" used in the provisions of this Law (excepting the provisions of Article 27 to 29 inclusive, Article 37, Article 55 paragraph 1 item (4), Article 84-2 paragraph 1 item (1), Article 88, Article 94 and Article 115) shall be construed as including national treasures.
  3. The term "historic sites, places of scenic beauty and/or natural monuments" used in the provisions of this Law (excepting the provisions of Article 69, Article 70, Article 71, Article 77, Article 83 paragraph 1 items (4), Article 84-2 paragraph 1 items (5) and (6), Article 88 and Article 94), shall be construed as including special historic sites, places of scenic beauty and/or natural monuments.

(Duty of the Government and Local Public Bodies)

Article 3. The Government and the local public bodies shall, recognizing that the cultural properties of the country are indispensable to the correct understanding of its history, culture, etc., and that they form a foundation for its cultural development for the future, make efforts to ensure that the purport of this Law is thoroughly understood by the public, so that such properties may be duly preserved.

(Attitude of the People, Owners, etc.)

Article 4. The people in general shall faithfully cooperate in the measures taken by the Government and the local public bodies for the attainment of the purpose of this Law.

2. The owners of cultural properties and other persons concerned shall preserve such properties with good care and utilize them for cultural purposes by opening them to the public or by other means, in full consciousness that cultural properties are valuable national possessions.

3. In the execution of this Law, the Government and the local public bodies shall respect the ownership and other property rights of the persons concerned.

## CHAPTER II Deleted.

Articles from 5 to 26 inclusive. Deleted.

## CHAPTER III Tangible Cultural Properties

### Section 1. Important Cultural Properties

#### Subsection 1. Designation

(Designation)

**Article 27.** The Minister of Education may designate important items of tangible cultural properties as important cultural properties.

2. From among the important cultural properties, the Minister of Education may designate as national treasures those properties which are of especially high value from the viewpoint of world culture and which are the matchless treasures of the nation.

(Announcement, Notice and Issuance of Certificate of Designation)

**Article 28.** Designation under the provision of the preceding Article shall be made by an announcement in the Official Gazette and also by the issuance of a notice thereof to the owner of the national treasure or the important cultural property concerned.

2. Designation under the provision of the preceding Article shall come into effect as from the day of its announcement in the Official Gazette made in accordance with the provision of the preceding paragraph; however, it shall come into effect for the owner of the national treasure or the important cultural property concerned as from the time when the notice provided for in the same paragraph reached the said owner.
3. When the designation under the provision of the preceding Article has been made, the Minister of Education shall issue a certificate of designation to the owner of the national treasure or the important cultural property concerned.
4. The items to be entered in the certificate of designation and other necessary matters relative to such certificate shall be determined by the Ministry of Education Ordinance.
5. When the owner has received the certificate of designation of the national treasure in accordance with the provision of paragraph 3, he/she shall return to the Minister of Education within thirty (30) days the certificate of designation of the important cultural property which has now been designated as a national treasure.

(Annulment)

**Article 29.** In case a national treasure or an important cultural property has lost its value as such or in case there is any other special reason, the Minister of Education may annul the designation of such national treasure or important cultural property.

2. The annulment of designation under the provision of the preceding paragraph shall be made by an announcement in the Official Gazette and also by the issuance of a notice thereof to the owner of the national treasure or the important cultural property concerned.
3. To the annulment of designation under the provision of paragraph 1, the provision of paragraph 2 of the preceding Article shall apply *mutatis mutandis*.



4. When the owner has received the notice under paragraph 2, he/she shall return to the Minister of Education the certificate of designation within thirty (30) days.
5. In cases where the designation of a national treasure has been annulled under paragraph 1, but where the designation of the same tangible property as an important cultural property has not been annulled, the Minister of Education shall issue to the owner without delay a certificate designating the same property as an important cultural property.

#### Subsection 2. Custody

(Instruction respecting Method of Custody)

**Article 30.** The Commissioner of the Agency for Cultural Affairs may give necessary instructions to the owner of an important cultural property with respect to the custody thereof.

(Owner's Duty of Custody, and Custodian)

**Article 31.** The owner of an important cultural property shall undertake the custody thereof, in accordance with this Law, as well as the Ministry of Education Ordinances and the instructions of the Commissioner of the Agency for Cultural Affairs, issued thereunder.

2. The owner of an important cultural property may, when there exist special reasons, appoint an appropriate person to be responsible on his/her behalf for the custody of the same property (hereinafter in this Section and in Chapter VI referred to as "the custodian").
3. When the owner of an important cultural property has appointed a custodian in accordance with the provision of the preceding paragraph, such owner shall report in writing within twenty (20) days the appointment to the Commissioner of the Agency for Cultural Affairs, stating the matters prescribed by the Ministry of Education Ordinance, under joint signature with the custodian so appointed. This provision shall also apply to the cases where the custodian has been released of the responsibility.
4. The provisions of the preceding Article and paragraph 1 of this Article shall apply *mutatis mutandis* to the custodian.

(Changes of Owner or Custodian)

**Article 32.** When the owner of an important cultural property has been changed, the new owner shall report in writing within twenty (20) days the changes to the Commissioner of the Agency for Cultural Affairs, stating the matters prescribed by the Ministry of Education Ordinance, attaching to the report the certificate of designation issued to the former owner.

2. The owner of an important cultural property shall, when he/she has changed the custodian, report in writing within twenty (20) days the change to the Commissioner of the Agency for Cultural Affairs, stating the matters prescribed by the Ministry of Education Ordinance, under joint signature with the newly appointed custodian. In this case the provision of paragraph 3 of the preceding Article shall not apply.
3. The owner or the custodian of an important cultural property shall, when he/she has changed his/her name, title or address, report in writing within twenty (20) days the change to the Commissioner of the Agency for Cultural Affairs, stating the matters prescribed by the Ministry of Education Ordinance. When the change has occurred in the name, title or address of the owner, he/she shall attach the certificate of designation to the report to be submitted.

(Custody by Custodial Body)

**Article 32-2.** With regard to an important cultural property, in cases where its owner is not traceable, or where it is obvious that the custody by the owner or the custodian is extremely difficult or inadequate, the Commissioner of the Agency for Cultural Affairs may appoint an appropriate local public body or any other appropriate juridical person and charge it with the conduct of custody necessary for the preservation of such important cultural property (including the safe-keeping of such facilities, equipments or any other objects as

are needed for its preservation and are owned by or in the custody of the owner of the said important cultural property).

2. In order to make an appointment under the provision of the preceding paragraph, the Commissioner of the Agency for Cultural Affairs shall in advance obtain the consent of the owner of the important cultural property concerned (excluding the case where the owner is not traceable) and of its possessor/occupant by title, as well as that of the local public body or other juridical person to be appointed.
3. The appointment under the provision of paragraph 1 shall be made by an announcement in the Official Gazette and also by the issuance of an notice thereof to the owner, the possessor/occupant and the local public body or other juridical person, prescribed in the preceding paragraph.
4. To the appointment under the provision of paragraph 1 the provision of Article 28 paragraph 2 shall apply *mutatis mutandis*.
5. The owner or the possessor/occupant of an important cultural property shall not, without justifiable reasons, refuse, interfere with or evade the act of custody or the execution of measures necessary for the custody by the local public body or other juridical person appointed in accordance with the provision of paragraph 1 (hereinafter in this Section and Chapter VI referred to as the "custodial body").
6. The provisions of Article 30 and Article 31 paragraph 1 shall apply *mutatis mutandis* to the custodial body.

**Article 32-3.** In cases where the reasons provided for in paragraph 1 of the preceding Article have become extinct or where there is any other special reasons, the Commissioner of the Agency for Cultural Affairs may annul the appointment of the custodial body.

2. The provisions of paragraph 3 of the preceding Article and of Article 28 paragraph 2 shall apply *mutatis mutandis* to the annulment under the provision of the preceding paragraph.

**Article 32-4.** The expenses required for the custody by the custodial body shall, unless otherwise provided for in this Law, be borne by the said body.

2. Notwithstanding the provision of the preceding paragraph, part of the expenses required for the custody may be borne by the owner, in accordance with what may be agreed upon by the custodial body and the owner, within the limits of the material profit which the latter will enjoy as a result of the custody conducted by the former.

(Destruction, Damage, etc.)

**Article 33.** When whole or part of an important cultural property has been destroyed, damaged, found missing or stolen, the owner (or the custodial or the custodial body, if such has been appointed) shall report it in writing to the Commissioner of the Agency for Cultural Affairs within ten (10) days of the knowledge of the fact, stating the matters prescribed by the Ministry of Education Ordinance.

(Change of Location)

**Article 34.** When the location of an important cultural property is to be changed, the owner (or the custodian or the custodial body, if such has been appointed) shall report it in writing to the Commissioner of the Agency for Cultural Affairs at least twenty (20) days prior to the date on which the location is to be changed, stating the matters prescribed by the Ministry of Education Ordinance and attaching to the report the certificate of designation. However, in cases provided for by the Ministry of Education Ordinance, it may be unnecessary to report it at all or to attach the certificate of designation to the report, or it may suffice to file an *ex post facto* report in accordance with the provisions of the Ministry of Education Ordinance.

### Subsection 3. Protection

#### (Repair)

**Article 34-2.** The repair of an important cultural property shall be conducted by its owner. It shall, however, be conducted by the custodial body, if such has been appointed.

#### (Repair by Custodial Body)

**Article 34-3.** In case the custodial body conducts the repair of the important cultural property in its custody, the said body shall in advance hear the opinions of the owner of the said property (except for the cases where the owner is not traceable) and of its possessor/occupant by title in regard to the method and the time of the repair.

2. The provisions of Article 32-2 paragraph 5 and Article 32-4 shall apply *mutatis mutandis* in case the custodial body conducts such repair.

#### (Subsidy for Custody or Repair)

**Article 35.** In cases where the owner of an important cultural property or its custodial body is unable to bear the large expenses required for the custody or repair of such property, or where there exist any other special circumstances, the Government may grant a subsidy to the said owner or custodial body so as to cover part of such expenses.

2. In cases where a subsidy under the preceding paragraph is granted, the Commissioner of the Agency for Cultural Affairs may, as a condition thereof, instruct necessary matters with respect to the custody or repair.
3. The Commissioner of the Agency for Cultural Affairs may, if he/she deems it necessary, direct and supervise the custody or repair of the important cultural property for which a subsidy is granted under the provision of paragraph 1.

#### (Order or Advice on Custody)

**Article 36.** When the Commissioner of the Agency for Cultural Affairs concludes that the important cultural property is in danger of destruction, damage or theft because of the incompetence of the person who is in charge of its custody, or of the inappropriate method of custody, he/she may order or advise the owner, custodian or custodial body of such property with respect to the measures necessary for its custody, such as the appointment or change of the person in charge of its custody, the improvement of the method of custody, the provision of fire prevention and other facilities for its preservation.

2. The expenses required for such measures as may be taken in conformity with the order or advice given under the provision of the preceding paragraph may be borne, in whole or in part, by the National Treasury in accordance with what may be provided for by the Ministry of Education Ordinance.
3. The provision of paragraph 3 of the preceding Article shall apply *mutatis mutandis* to the cases where whole or part of the expenses is borne by the National Treasury under the provision of the preceding paragraph.

#### (Order or Advice on Repair)

**Article 37.** When a national treasure is damaged, and the Commissioner of the Agency for Cultural Affairs deems it necessary to repair it in view of its proper preservation, he/she may give necessary order or advice on its repairs to the owner or the custodial body concerned.

2. In cases where an important cultural property other than a national treasure is damaged, and the Commissioner of the Agency for Cultural Affairs deems it necessary to repair it in view of its proper preservation, he/she may give necessary advice on its repair to the owner or the custodial body concerned.
3. The expenses required for the repair conducted in conformity with the order or advice given under the provisions of the preceding two paragraphs may be borne in whole or in part by the National Treasury in accordance with what may be provided for by the Ministry of Education Ordinance.

4. The provision of Article 35 paragraph 3 shall apply *mutatis mutandis* to the cases where whole or part of the expenses is borne by the National Treasury in accordance with the provision of the preceding paragraph.

(Execution of Repair, etc. of National Treasure by the Commissioner of the Agency for Cultural Affairs)

**Article 38.** The Commissioner of the Agency for Cultural Affairs himself/herself may, in either of the following cases, undertake the repair of national treasures or take preventive measures against their destruction, damage or theft:

- (1) When the owner, the custodian or the custodial body does not comply with the order given in accordance with the provision of the preceding two Articles;
  - (2) When, in cases where the national treasure has been damaged or where it is in danger of destruction, damage or theft, it is deemed inadvisable to have the repair undertaken or the preventive measures against destruction, damage or theft taken by the owner, the custodian or the custodial body.
2. When the Commissioner of the Agency for Cultural Affairs intends to undertake the repair or take measures under the provisions of the preceding paragraph, he/she shall in advance issue a writ to the owner, the custodian or the custodial body concerned stating the necessary items such as the name of the national treasure in question, the substance of the repair or measures, the date of commencement of the work and others, and at the same time give notice thereof to its possessor/occupant by title.

**Article 39.** The Commissioner of the Agency for Cultural Affairs shall, in undertaking the repair or measures under the provision of paragraph 1 of the preceding Article, appoint from among the staff members of the Agency for cultural Affairs a person or persons who are to be responsible for the execution of the said repair or measures and for the custody of the national treasure concerned.

2. The person or persons who have been appointed as responsible persons under the provision of the preceding paragraph shall, when they execute the said repair or measures, carry with them their identity cards, show them upon demand to the parties concerned, and duly respect the reasonable opinions of such parties.
3. To the execution of the repair and measures under the provision of paragraph 1 of the preceding Article, the provision of Article 32-2 paragraph 5 shall apply *mutatis mutandis*.

**Article 40.** The expenses required for the repairs or measures executed under the provision of Article 38 paragraph 1 shall be defrayed from the National Treasury.

2. The Commissioner of the Agency for Cultural Affairs may, in accordance with what may be provided for by the Ministry of Education Ordinance, charge the owner (or the custodial body, if such has been appointed) part of the expenses required for the repair or measures executed under the provision of Article 38 paragraph 1; however, this shall apply exclusively to either of the cases, falling under paragraph 1 item (2) of the same Article, where the immediate causes which brought about the necessity of such repair or measures rest with the owner, the custodian or the custodial body, or where the owner or the custodial body is capable of bearing part of such expenses.
3. To the charging of expenses under the preceding paragraph, the provisions of Articles 5 and 6 of the Law for Administrative Execution by Proxy (Law No. 43 of 1948) shall apply *mutatis mutandis*.

**Article 41.** The State shall indemnify the person or persons, who have suffered a loss in the repairs or measures executed under the provision of Article 38 paragraph 1, for the ordinary damage incidental thereto.

2. The amount of indemnity payable under the preceding paragraph shall be determined by the Commissioner of the Agency for Cultural Affairs.
3. Any person who is not satisfied with the amount of the indemnity payable under the preceding paragraph may demand an increase in the amount by litigation; however, this shall not apply when three (3) months have passed after receiving the notice of determination of the indemnity mentioned in the same paragraph.
4. In case of litigation under the preceding paragraph, the State shall be the defendant.

(Reimbursement in case of Assignment of Important Cultural Property for which Subsidy, etc. has been granted)

Article 42. In case the then owner of the important cultural property for which the State has granted subsidies under Article 35 paragraph 1 or borne expenses under Article 36 paragraph 2, Article 37 paragraph 3 or Article 40 paragraph 1, for the repairs or preventive measures against destruction, damage or theft (hereinafter in this Article referred to as "repairs, etc."), his/her heir, legatee or donee (including the second or subsequent heir, legatee or donee; hereinafter the same in this Article) (hereinafter in this Article referred to as "owner, etc.") has assigned the said important cultural property for a consideration after performance of the repairs, etc. for which the State granted subsidies or borne expenses, he/she shall reimburse the National Treasury in accordance with what may be provided for by the Ministry of Education Ordinance the total amount of the said subsidies or expenses defrayed by the State (as for the expenses borne by the National Treasury under the provision of Article 40 paragraph 1, the amount of such expenses less what amount of money as was charged to the owner in accordance with the provision of paragraph 2 of the same Article; hereinafter the same in this Article) minus the sum spent by himself/herself for repairs, etc. of the said cultural property since the performance of the said repairs, etc. (hereinafter in this Article referred to as "the amount of reimbursement").

2. "The amount of subsidies or expenses defrayed by the State" provided for in the preceding paragraph shall be the sum corresponding to that which is arrived at by dividing the amount of the subsidies or the expenses defrayed by the State by the number of durable years fixed individually by the Commissioner of the Agency for Cultural Affairs in regard to the important cultural property or its parts subjected to such repairs, etc. and then by multiplying the quotient by the number of residual years (discarding the fractional period less than a year) which is obtained by deducting from such number of years that have passed since the time of the repairs, etc. until the time of assignment of the same property.
3. In case the value of such important cultural property has fallen off considerably through a cause not imputable to the owner, etc., or in case he/she has assigned the said important cultural property to the State, after the performance of the repairs, etc. for which the State granted subsidies or bore expenses, the Commissioner of the Agency for Cultural Affairs may exempt whole or part of the amount of reimbursement.
4. In case the person in question fails to pay off within the time limit fixed by the Commissioner of the Agency for Cultural Affairs the amount of reimbursement for which he/she is held due, the State may collect it following suit of coercive collection of national tax. In this case, the order of priority in collection shall be next to national and local taxes.
5. In case the person who is to pay the amount of reimbursement is the heir, legatee or donee, the sum corresponding to the quotient, obtained by dividing the sum equivalent to the balance between the amount of inheritance tax or donation tax provided for in item (1) and the amount provided for in item (2), by the number of years provided for in item (3), multiplied by the number of years provided for in item (4), shall be deducted from the amount of reimbursement he/she is to be charged:
  - (1) The amount of inheritance tax or donation tax the person concerned has already paid or is obliged to pay in acquiring the important cultural property concerned;
  - (2) The amount corresponding to that of inheritance tax or donation tax which is supposed to be imposed upon the person concerned for the important cultural property or its parts in question which is or are included in the value of assessment used as a basis of calculation of the tax under the preceding item, when worked out on the bases of the same value of assessment less the total amount of the subsidies or the expenses, mentioned in paragraph 1, defrayed by the State for the repairs, etc. which have been carried out prior to the time of such inheritance, bequest or donation in regard to the said important cultural property or its parts in question;
  - (3) The number of residual years (discarding the fractional period less than a year) obtained by deducting from the number of durable years fixed by the Commissioner of the Agency for Cultural Affairs concerning the important cultural property or its parts in question, in accordance with the provision of paragraph 2, the number of years that have passed since the time of performance of such repairs, etc. until the time of inheritance, bequest or donation of the property concerned;

- (4) The number of residual durable years of the important cultural property or its parts in question, provided for in paragraph 2.
6. With respect to the amount of subsidies or expenses defrayed by the State as provided for in paragraph 1, which is referred to in item (2) of the preceding paragraph, the provision of paragraph 2 shall apply *mutatis mutandis*. In this case, "the time of assignment" in the same paragraph shall read "the time of inheritance, bequest or donation."
7. In the assessment of the amount of capital gains under Article 33 paragraph 1 of the Income Tax Law (Law No. 33 of 1965) relative to the assignment provided for in paragraph 1 of this Article by the person who pays the amount of reimbursement according to the provision of the same paragraph, the amount he/she reimburses thereunder shall be taken as the expenses related to the assignment as provided for in Article 33 paragraph 3 of the same Law.

(Restriction on Alteration of Existing State)

**Article 43.** In case any person intends to alter the existing state of an important cultural property or to do an act affecting its preservation, he/she shall obtain the permission of the Commissioner of the Agency for Cultural Affairs; however, this shall not apply to the cases where such act as altering the existing state is merely a measure of maintenance or an emergency measure to be taken in the event of an unforeseen disaster, or to the case where the consequences to be entailed by the act which may affect preservation is only trifling.

2. The extent of the measure of maintenance referred to in the proviso to the preceding paragraph shall be established by the Ministry of Education Ordinance.
3. In giving the permission under paragraph 1, the Commissioner of the Agency for Cultural Affairs may give necessary instructions as a condition thereof regarding the alteration of the existing state or the act affecting the preservation under the same paragraph.
4. In case the person who has received the permission under paragraph 1 has failed to observe the condition of the permission provided for in the preceding paragraph, the Commissioner of the Agency for Cultural Affairs may order the suspension of the act of altering the existing state or of the act affecting the preservation, for which the permission has been given, or cancel the permission.
5. The State shall indemnify the person or persons who have suffered a loss from the fact that they failed to obtain the permission under paragraph 1 or that the permission given was attached with conditions under paragraph 3, for the ordinary damage incidental thereto.
6. To the cases under the preceding paragraph the provisions of Article 41 paragraphs 2 to 4 inclusive shall apply *mutatis mutandis*.

(Report on Repairs, etc.)

**Article 43-2.** In case any important cultural property is to be repaired, its owner or its custodial body shall report it to the Commissioner of the Agency for Cultural Affairs in writing in accordance with what may be provided for by the Ministry of Education Ordinance, at least thirty (30) days prior to the date on which such repair is to be started; however, this shall not apply to the cases where the permission must needs be applied for in accordance with the provision of paragraph 1 of the preceding Article and to those other cases as provided for by the Ministry of Education Ordinance.

2. In case the Commissioner of the Agency for Cultural Affairs deems it necessary for the protection of the important cultural property, he/she may provide technical guidance and advice in regard to the repair of the important cultural property which has been reported under the preceding paragraph.

(Prohibition of Exportation)

**Article 44.** Any important cultural property shall not be exported; this shall not apply, however, in case the Commissioner of the Agency for Cultural Affairs has given permission therefor in recognition of its special necessity from the viewpoint of international exchange of culture or from other considerations.

(Integrity of Surroundings)

**Article 45.** The Commissioner of the Agency for Cultural Affairs may, when he/she deems it necessary for the preservation of the important cultural property, restrict or prohibit certain kinds of acts or order the provision of necessary facilities, within an area designated by him/her.

2. The State shall indemnify the person or persons who have suffered a loss from the dispositions taken in accordance with the provision of the preceding paragraph for the ordinary damage incidental thereto.
3. To the cases under the preceding paragraph the provisions of Article 41 paragraphs 2 to 4 inclusive shall apply *mutatis mutandis*.

(Offer of Sale to the State)

**Article 46.** Any person who desires to assign an important cultural property for a consideration shall beforehand file in writing with the Commissioner of the Agency for Cultural Affairs an offer of sale of the said property to the State, stating therein the name of the assignee, the estimated value of the consideration (the value has to be calculated in money at the current price in case the consideration stipulated consists in things other than money; hereinafter the same) and any other matters prescribed by the Ministry of Education Ordinance.

2. The circumstances surrounding wanting to make assignation to the said assignee may be listed in the written offer of the preceding paragraph.
3. When the Commissioner of the Agency for Cultural Affairs has determined that the circumstances listed according to the provisions of the preceding paragraph are reasonable, then within thirty (30) days from the making of the said offer, notice shall be given that the said important cultural property shall not be bought.
4. When the Commissioner of the Agency for Cultural Affairs has, within thirty (30) days from the offer of sale filed under the provision of paragraph 1, given notice that the State will buy the said important cultural property, a bargain shall be deemed to have been closed at a price corresponding to the estimated value of the consideration stated in the paper referred to in paragraph 1.
5. The person stipulated in paragraph 1 shall not transfer the said important cultural property within the period specified in the preceding paragraph (or until the time within that period when the Commissioner of the Agency for Cultural Affairs has noticed that the same important cultural property will not be bought by the State).

(Subsidy for Purchase by Custodial Body)

**Article 46-2.** In case the local public body or other juridical person which is a custodial body is to purchase an important cultural property in its custody (exclusively building, other fixture to land, and the land which combined with such fixture is covered by the designation as the said important cultural property) in view of its positive necessity for the purpose of ensuring the preservation thereof, the State may grant a subsidy to cover part of the expenses required for the said purchase.

2. To the cases under the preceding paragraph the provisions of Article 35 paragraphs 2 and 3 and the preceding paragraph shall apply *mutatis mutandis*.

(Trust of Custody or Repair, or Technical Guidance)

**Article 47.** The owner of the important cultural property (or the custodial body if such has been appointed) may entrust the Commissioner of the Agency for Cultural Affairs with the custody (excluding the cases where the custodial body has been appointed) or repair thereof on the conditions determined by the same Commissioner.

2. The Commissioner of the Agency for Cultural Affairs may, in case he/she deems it necessary for the preservation of the important cultural property, advise its owner (or the custodial body if such has been appointed), presenting him/her conditions, to entrust the same Commissioner with the custody (excluding the cases where the custodial body has been appointed) or repair of such property.

3. The provisions of Article 39 paragraphs 1 and 2 shall apply *mutatis mutandis* to the cases where the Commissioner of the Agency for Cultural Affairs has been entrusted with the custody or repair of the important cultural property in accordance with the preceding two paragraphs.
4. The owner, custodian, or custodial body of the important cultural property may request the Commissioner of the Agency for Cultural Affairs, in accordance with what may be provided for by the Ministry of Education Ordinance, for technical guidance respecting the custody or repair of the important cultural property concerned.

#### Subsection 4. Opening to the Public

##### (Opening to the Public)

**Article 47-2.** Opening to the public of the important cultural property shall be undertaken by its owner; however, it shall be undertaken by the custodial body, if such has been appointed.

2. Notwithstanding the provision of the preceding paragraph, a person or persons other than the owner and the custodial body may throw open to public viewing, organized under the provisions of this Law, the important cultural property which the owner or the custodial body concerned agree to display.
3. The custodial body may collect admission fees from the visitors in opening to the public the important cultural property in its custody.

##### (Opening to the Public by the Commissioner of the Agency for Cultural Affairs)

**Article 48.** The Commissioner of the Agency for Cultural Affairs may advise the owner (the custodial body if such has been appointed) of the important cultural property to display the property for a term not exceeding one year at the public viewing to be held by the same Commissioner at the National Museums or other institutions.

2. The Commissioner of the Agency for Cultural Affairs may order the owner (the custodial body if such has been appointed) of the important cultural property, for the custody or repair of which the National Treasury has defrayed whole or part of the expenses or granted subsidies, to display the property for a term not exceeding one year at the public viewing to be held by the same Commissioner at the National Museums or other institutions.
3. When the Commissioner of the Agency for Cultural Affairs deems it necessary in the cases under the preceding paragraph, he/she may renew the term of display for a limited period not exceeding one year; however, such renewal shall in no case exceed a period of five consecutive years.
4. When an order is issued under paragraph 2 or the period of display is renewed under the preceding paragraph, the owner or the custodial body of the important cultural property concerned must so display it.
5. Other than the cases provided for in the preceding four paragraphs, the Commissioner of the Agency for Cultural Affairs may, if he/she deems it appropriate, accept the proposal made by the owner (the custodial body if such has been appointed) of the important cultural property to display such property at the public viewing to be held by the same Commissioner at the National Museums or other institutions.

**Article 49.** Excepting the cases provided for in Article 100, the Commissioner of the Agency for Cultural Affairs shall, when important cultural properties are displayed in accordance with the provisions of the preceding Article, appoint from among the staff members of the Agency for Cultural Affairs a person or persons who are to be responsible for the custody of such properties.

**Article 50.** Expenses required for the display under the provision of Article 48 shall be defrayed from the National Treasury in accordance with the standards prescribed by the Ministry of Education Ordinance.

2. The Government shall, in accordance with the standards prescribed by the Ministry of Education Ordinance, give compensation to the owner or the custodial body of the property which has been displayed under the provisions of Article 48.



(Opening to the Public by the Owner, etc.)

**Article 51.** The Commissioner of the Agency for Cultural Affairs may advise the owner or the custodial body of the important cultural property to open such property to the public for a limited period not exceeding three (3) months.

2. The Commissioner of the Agency for Cultural Affairs may order the owner or the custodial body of the important cultural property, for the custody, repair or purchase of which the National Treasury has defrayed whole or part of the expenses or granted subsidies, to open such property to the public for a limited period not exceeding three (3) months.
3. The provision of Article 48 paragraph 4 shall apply *mutatis mutandis* to the cases under the preceding paragraph.
4. The Commissioner of the Agency for Cultural Affairs may give necessary instructions to the owner or the custodial body of the important cultural property concerning the opening to the public of such property to be made under the provisions of the preceding three (3) paragraphs and the custody thereof during such public viewing.
5. In case the owner, the custodian or the custodial body of the important cultural property fails to observe the instructions mentioned in the preceding paragraph, the Commissioner of the Agency for Cultural Affairs may order the suspension or discontinuance of the act of such public viewing.
6. The expenses required for opening such property to the public under the provisions of paragraphs 2 and 3 may, in accordance with what may be provided for by the Ministry of Education Ordinance, be defrayed in whole or in part from the National Treasury.
7. Other than the case provided for in the previous paragraph, expenses required by the owner or the custodial body of the important cultural property for the opening of the said property shall be wholly or partially defrayed from the National Treasury in accordance with what may be provided for by the Ministry of Education Ordinance.

**Article 51-2.** Except for the occasions of public viewing under the preceding Article, in the cases where a report has been filed in accordance with the provision of Article 34 with a view to moving the important cultural property from its domicile to some other place where it will be shown to the public, the provisions of paragraphs 4 and 5 of the preceding Article shall apply *mutatis mutandis*.

(Indemnification for Loss)

**Article 52.** In case an important cultural property has been destroyed or damaged as a result of its display or public viewing conducted in accordance with the provisions of Article 48 or Article 51 paragraphs 1 to 3 inclusive, the State shall indemnify its owner for the ordinary damage incidental to it; however, this provision shall not apply in case the destruction or damage has resulted from a cause imputable to the owner, to the custodial or to the custodial body.

2. The provisions of Article 41 paragraphs 2 to 4 inclusive shall apply *mutatis mutandis* to the cases under the preceding paragraph.

(Opening to the Public by Person other than Owner, etc.)

**Article 53.** When any person other than the owner and the custodial body of the important cultural property intends to show such property to the public at an exhibition or on any other public occasion to be held under his/her own auspices, such person shall obtain the permission of the Commissioner of the Agency for Cultural Affairs therefor; however, this shall not apply in case such exhibition or other event is to be held under the auspices of a State agency other than the Commissioner of the Agency for Cultural Affairs or of a local public body at a museum or other similar institution which has previously been approved by the Commissioner of the Agency for Cultural Affairs (hereinafter in this paragraph referred to as "public approved institutions"), or when the person who has established a public approved institution holds such an event at the said public approved institution.

2. In the proviso of the preceding paragraph, a person holding an event stipulated in that paragraph (except for the Commissioner of the Agency for Cultural Affairs) shall, within 20 days from the day following the conclusion of the public display of that important cultural property, give written notice of the items stipulated in the Ministry of Education Ordinance to the Commissioner of the Agency for Cultural Affairs.
3. In giving permission under paragraph 1, the Commissioner of the Agency for Cultural Affairs may give as a condition thereof necessary instructions with respect to the public viewing for which permission is to be given and to the custody of the important cultural property to be on display.
4. When any person who obtained the permission under paragraph 1 has failed to observe the conditions of the permission provided for in the preceding paragraph, the Commissioner of the Agency for Cultural Affairs may order the suspension of the public viewing for which he/she has given permission.

#### Subsection 5. Investigation

(Investigation for the Purpose of Preservation)

**Article 54.** The Commissioner of the Agency for Cultural Affairs may, when he/she deems it necessary, ask the owner, custodian or custodial body of an important cultural property to report on the existing state of such property, or on the conditions of its custody, of its repairs or of the preservation of the integrity of its surroundings.

**Article 55.** In any of the following cases, when the Commissioner of the Agency for Cultural Affairs is unable to confirm the conditions of a particular important cultural property in spite of all the information given in the report filed under the preceding Article and when there appears to be no alternative way for the confirmation thereof, he/she may appoint a person or persons to conduct an investigation, and cause them to enter the place where the said property exists and conduct an on-the-spot investigation in regard to the existing state of the property or the conditions of its custody, of its repairs or of the preservation of the integrity of its surroundings:

- (1) Where application has been filed for the permission for alteration of the existing state of the important cultural property or for the act affecting its preservation;
  - (2) Where the important cultural property has been damaged or where there has been a change in its existing state or its location;
  - (3) Where there is a fear of destruction, damage or theft of the important cultural property;
  - (4) Where there is necessity of revaluing the qualifications of a cultural property classified as national treasure or important cultural property because of special circumstances.
2. In the event of any investigation to be conducted by entering the place under the preceding paragraph, the person or persons who are to engage in such investigation shall carry with them their identity cards, show them upon demand to the parties concerned, and duly respect the reasonable opinions of such parties.
  3. The State shall indemnify the person or persons who have suffered a loss in the investigation conducted in accordance with the provision of paragraph 1 for the ordinary damage incidental thereto.
  4. The provision of Article 41 paragraphs 2 to 4 inclusive shall apply *mutatis mutandis* to the cases under the preceding paragraph.

#### Subsection 6. Miscellaneous Provisions

(Succession to Rights and Obligations on Change of Owner, etc.)

**Article 56.** In case the owner of an important cultural property has changed, the new owner shall with reference to the said property succeed to the rights and obligations of the former owner established by the orders, advices, instructions and other dispositions of the Commissioner of the Agency for Cultural Affairs issued or made under this Law.

2. In the cases under the preceding paragraph, the former owner shall deliver to the new owner the certificate of designation concerned *simultaneously* with the delivery of such important cultural property.
3. To the case where a custodial body has been appointed or the appointment thereof has been annulled, the provision of paragraph 1 shall apply *mutatis mutandis*; in case of the appointment of the custodial body, however, this provision shall not apply to the rights and obligations which should belong exclusively to the owner.

## Section 2. Registered Tangible Cultural Properties

### (Registration of Tangible Cultural Property)

**Article 56-2.** Among tangible cultural properties other than important cultural properties (excluding those designated by local public bodies under the provisions of Article 98-2) which are buildings, the Minister of Education can, in view of the value of those cultural properties, register those which are in particular need of preservation and utilization measures in the Cultural Property Original Register.

2. When undertaking registrations under the preceding paragraph, the Minister of Education shall obtain the opinions of pertinent local public bodies in advance.
3. The items to be registered in the Cultural Property Original Register and other necessary matters relative to the Cultural Property Original Register shall be determined by the Ministry of Education Ordinance.

### (Announcement, Notice and Issuance of Certificate of Designation)

**Article 56-2-2.** Registration under the provision of paragraph 1 of the preceding Article shall be made by an announcement in the Official Gazette and also by the issuance of a notice thereof to the owner of the tangible cultural property concerned (hereinafter referred to as the "registered tangible cultural property").

2. Registration under the provision of paragraph 1 of the preceding Article shall come into effect as from the day of its announcement in the Official Gazette made in accordance with the provision of the preceding paragraph; however, it shall come into effect for the owner of the registered tangible cultural property concerned as from the time when the notice provided for in the same paragraph reached the said owner.
3. When the registration under the provision of paragraph 1 of the preceding Article has been made, the Minister of Education shall issue a certificate of registration to the owner of the registered tangible cultural property concerned.
4. The items to be entered in the certificate of registration and other necessary matters relative to such certificate shall be determined by the Ministry of Education Ordinance.

### (Annulment of Registrations of Registered Tangible Cultural Property)

**Article 56-2-3.** In case a registered tangible cultural property has been designated an important cultural property under the provision of Article 27-1, or when it has been designated by a local public body under the provision of Article 98-2, the Minister of Education shall annul that registration.

2. In case a registered tangible cultural property has lost its need of preservation and utilization measures or in case there is any other special reason, the Minister of Education may annul that registration.
3. In case of an annulment of registration under the provision of the two preceding paragraphs, prompt announcement to that effect shall be made in the Official Gazette and also notification shall be issued to the owner of the registered tangible cultural property concerned.
4. To the annulment of registration under the provision of paragraphs 1 and 2, the provision of paragraph 2 of the preceding Article shall apply *mutatis mutandis*.
5. When the owner has received the notice under paragraph 3, he shall return to the Minister of Education the certificate of registration within thirty (30) days.

### (Custody of Registered Tangible Cultural Property)

**Article 56-2-4.** The owner of a registered tangible cultural properties shall undertake the custody thereof, in accordance with this Law as well as the Ministry of Education Ordinances based hereupon.

2. The owner of a registered tangible cultural property may, when there exist special reasons, appoint an appropriate person to be responsible on his behalf for the custody of the said property (hereinafter in this Section referred to as "the custodian").
3. With regard to a registered tangible cultural property, in cases where the owner is not traceable, or where it is obvious that the custody by the owner or the custodian is extremely difficult or inadequate, the Commissioner of the Agency for Cultural Affairs may appoint an appropriate local public body or any other appropriate juridical person (hereinafter in this Section referred to as "the custodial body") and charge it with the conduct of custody necessary for the preservation of the said registered tangible cultural property (including the safe-keeping of such facilities, equipment or any other items as are needed for its preservation and which are owned by or in the custody of the owner of the said registered tangible cultural property).
4. To the custody of the registered tangible cultural property, the provisions of Article 31-3, Article 32, Article 32-2 paragraphs 2 to 5 inclusive, Article 32-3 and Article 32-4 shall apply *mutatis mutandis*.
5. The provisions of paragraph 1 shall apply *mutatis mutandis* to the custodian or the custodial body of the registered tangible cultural property.

(Destruction or Damage of Registered Tangible Cultural Property)

**Article 56-2-5.** When the whole or part of a registered tangible cultural property has been destroyed or damaged, the owner (or the custodian or the custodial body, if such has been appointed) shall report it in writing to the Commissioner of the Agency for Cultural Affairs within ten (10) days of the knowledge of the fact, stating the matter prescribed by the Ministry of Education Ordinance.

(Repair of Registered Tangible Cultural Property)

**Article 56-2-6.** The repair of a registered tangible cultural property shall be done by its owner; however, it shall be done by the custodial body if such has been appointed.

2. In case the custodial body does the repair, the provisions of Article 32-2 paragraph 5, Article 32-4 and Article 34-3 paragraph 1 shall apply *mutatis mutandis*.

(Notifications, etc. on Alterations to the Existing State of a Registered Tangible Cultural Property)

**Article 56-2-7.** In case any person intends to alter the existing state of a registered tangible cultural property, he shall, no later than thirty (30) days prior to the intended date of effecting said alteration, submit notification thereof, as determined by the Ministry of Education Ordinance, to the Commissioner of the Agency for Cultural Affairs; however, this shall not apply to cases where such act as altering the existing state is merely a maintenance measure or an emergency measure to be taken in the event of an unforeseen disaster, or to cases where the existing state must be altered in order to comply with orders under the provisions of other legal statutes.

2. The scope of maintenance measures in the proviso of the previous paragraph shall be determined by Ministry of Education Ordinance.
3. When deemed to be necessary for the protection of a registered tangible cultural property, the Commissioner of the Agency for Cultural Affairs may give necessary instructions, advice, or remonstrations concerning alterations to the existing state of the said registered tangible cultural property pertaining to the notification of paragraph 1.

(Technical Guidance Concerning Custody or Repair of Registered Tangible Cultural Property)

**Article 56-2-8.** The owner, custodian or custodial body of a registered tangible cultural property can ask the Commissioner of Agency for Cultural Affairs for technical guidance respecting the maintenance or repair of the registered tangible cultural property concerned, in accordance with what may be provided for by the Ministry of Education Ordinance.

(Public Opening of Registered Tangible Cultural Property)

**Article 56-2-9.** Opening to the public of the registered tangible cultural property shall be undertaken by its owner; however, it shall be undertaken by the custodial body, if such as been appointed.

2. Notwithstanding the provision of the preceding paragraph, a party other than the owner and the custodial body may open to the public the registered tangible cultural property with the agreement of the owner (or the custodial body, if there is one).
3. To the public opening of a registered tangible cultural property by the custodial body, the provisions of Article 47-2, paragraph 3 shall apply *mutatis mutandis*.
4. When deemed necessary in the utilization of a registered tangible cultural property, the Commissioner of the Agency for Cultural Affairs may give necessary guidance or advice to the owner or custodial body of the said registered tangible cultural property concerning its public opening or concerning its custody with respect to its public opening.

(Reporting on the Existing State of a Registered Tangible Cultural Property)

**Article 56-2-10.** When the Commissioner of the Agency for Cultural Affairs deems it necessary, he may ask the owner, custodial or custodial body of a registered tangible cultural property to report on the existing state of such property, or on the state of its custody or repair.

(Transfer of Certificate of Registration Accompanying Changes of Ownership)

**Article 56-2-11.** In case the owner of a registered tangible cultural property has changed, the former owner shall deliver to the new owner the certificate of registration concerned simultaneously with the delivery of the said registered tangible cultural property.

### **Section 3. Tangible Cultural Properties other than Important Cultural Properties and Registered Tangible Cultural Properties**

(Technical Guidance)

**Article 56-2-12.** The owner of any tangible cultural property other than important cultural properties and registered tangible cultural properties may, in accordance with what may be provided for by the Ministry of Education, ask the Commissioner of the Agency for Cultural Affairs for technical guidance in regard to the custody or repair of such tangible cultural property.

## **CHAPTER III-2 Intangible Cultural Properties**

(Designation, etc. of Important Intangible Cultural Property)

**Article 56-3.** The Minister of Education may designate important items of intangible cultural properties as important intangible cultural properties.

2. The Minister of Education shall, in making the designation under the provision of the preceding paragraph, recognize the holder or holders who are the persons that represent the high standard of such important intangible cultural property, or the holding body which is composed mainly of the holders of such intangible cultural property and has its representative established by its own statute (hereinafter the same).
3. Designation under the provision of paragraph 1 shall be made by an announcement in the Official Gazette, and also by the issuance of a notice thereof to the person or the body to the recognized as the holder or the holding body, respectively, of the important intangible cultural property concerned (in case of a holding body, to its representative).
4. Even after making the designation under the provision of paragraph 1, the Minister of Education may, if in his/her opinion there still is a person or a body eligible to the recognition as the holder or the

holding body of a particular important intangible cultural property, make supplementary recognition as such.

5. To the supplementary recognition under the provision of the preceding paragraph the provision of paragraph 3 shall apply *mutatis mutandis*.

(Annulment of Designation, etc. of Important Intangible Cultural Property)

**Article 56-4.** In case an important intangible cultural property has lost its value as such, or in case there is any other special reason, the Minister of Education may annul the designation of such important intangible cultural property.

2. In case a holder is deemed to have become inadequate to maintain such title for his/her mental or physical reasons, or in case a holding body is deemed to have become inadequate to maintain such title for the change of its constituent members, or in case there is any other special reason, the Minister of Education may annul the recognition concerned.
3. The annulment of the designation under the provision of paragraph 1 or of the recognition under that of the preceding paragraph shall be made by an announcement in the Official Gazette, and also by the issuance of a notice thereof to the holder or the holding body of the important intangible cultural property concerned.
4. When a holder has died or a holding body has been dissolved (including the cases of its having become extinct; the same shall apply in this Article and the following one) his/her or its recognition as such shall be deemed to have been annulled; and when all the holders have died, or all the holding bodies have been dissolved, the designation of the important intangible cultural property concerned shall be deemed to have been annulled. In these cases the Minister of Education shall announce the fact in the Official Gazette.

(Change of Name of Holder, etc.)

**Article 56-5.** When a holder has changed his/her name or address, when he/she has died, or when there is any of such reasons as are provided for by the Ministry of Education Ordinance, such holder or his/her heir shall report the fact to the Commissioner of the Agency for Cultural Affairs in writing within twenty (20) days of the day on which it took place (in case of a holder's death, the day on which his/her heir came to know the fact), stating the matters prescribed by the Ministry of Education Ordinance. When a holding body has changed its name, the address of its office, or its representative, or when there is any change among its constituent members, or when the body has been dissolved the same provision shall apply to its representative (in case of dissolution, it shall apply to the person who has been its representative).

(Preservation of Important Intangible Cultural Property)

**Article 56-6.** When the Commissioner of the Agency for Cultural Affairs deems it necessary for the preservation of a particular important intangible cultural property, he/she may himself/herself take any appropriate measures for its preservation, such as recording, training successors in the arts, etc., and the State may aid its holder, its holding body or a local public body, or any other person or persons deemed appropriate for taking care of its preservation by granting a subsidy to cover part of the expenses required for its preservation.

2. To the subsidization under the provision of the preceding paragraph the provisions of Article 35 paragraphs 2 and 3 shall apply *mutatis mutandis*.

(Opening to the Public of Important Intangible Cultural Property)

**Article 56-7.** The Commissioner of the Agency for Cultural Affairs may advise the holder or the holding body of the important intangible cultural property to open the said property to the public, or the owner of the records of the important intangible cultural property to open such records to the public.

2. In case the holder or the holding body of the important intangible cultural property opens such property to the public, the provision of Article 51 paragraph 7 shall apply *mutatis mutandis*.
3. In case the owner of the records of the important intangible cultural property opens such records to the public, the State may grant a subsidy to cover part of the expenses required for the said opening.

4. To the subsidization under the provision of the preceding paragraph, the provisions of Article 35 paragraphs 2 and 3 shall apply *mutatis mutandis*.

(Suggestion or Advice on Preservation of Important Intangible Cultural Property)

**Article 56-8.** The Commissioner of the Agency for Cultural Affairs may give suggestions or advice necessary for the preservation of the important intangible cultural property to its holder or holding body, or a local public body or any other person who is deemed to be appropriate for taking care of its preservation.

(Recording, etc. of Intangible Cultural Property other than Important Intangible Cultural Property)

**Article 56-9.** The Commissioner of the Agency for Cultural Affairs may, selecting such items of the intangible cultural property as of special necessity, other than the important intangible cultural property, take himself records thereof, preserve such records or open the same to the public, and the State may subsidize an appropriate person to cover part of the expense required for opening such intangible cultural property to the public, or recording it, preserving such records or opening the same to the public.

2. To the subsidization under the provision of the preceding paragraph the provision of Article 35 paragraphs 2 and 3 shall apply *mutatis mutandis*.

### CHAPTER III-3 Folk-cultural Properties

(Designation of Important Tangible Folk-cultural Property and Important Intangible Folk-cultural Property)

**Article 56-10.** The Minister of Education may designate especially important items of tangible folk-cultural properties as important tangible folk-cultural properties, and especially important items of intangible folk-cultural properties as important intangible folk-cultural properties.

2. To the designation of the important tangible folk-cultural property under the provision of the preceding paragraph the provisions of Article 28 paragraphs 1 to 4 inclusive shall apply *mutatis mutandis*.
3. The designation of the important intangible folk-cultural property under the provision of paragraph 1 shall be made by an announcement in the Official Gazette.

(Annulment of Designation of Tangible Folk-cultural Property and Important Intangible Folk-cultural Property)

**Article 56-11.** In case any important tangible folk-cultural property or important intangible folk-cultural property has lost its value as such, or in case there is any other special reason, the Minister of Education may annul the designation of such important tangible folk-cultural property or important intangible folk-cultural property.

2. To the annulment of designation of the important tangible folk-cultural property under the provision of the preceding paragraph the provisions of Article 29 paragraphs 2 to 4 inclusive shall apply *mutatis mutandis*.
3. The annulment of designation of the important intangible folk-cultural property under the provision of paragraph 1 shall be made by an announcement in the Official Gazette.

(Custody of Important Tangible Folk-cultural Property)

**Article 56-12.** To the custody of important tangible folk-cultural property the provisions of Articles 30 to 34 inclusive shall apply *mutatis mutandis*.

(Protection of Important Tangible Folk-cultural Property)

**Article 56-13.** Any person who intends to alter the existing state of a particular important tangible folk-cultural property or to do an act affecting its preservation or to export it shall report it to the Commissioner of the Agency for Cultural Affairs in writing in accordance with what may be provided for by the Ministry of Education Ordinance at least twenty (20) days prior to the day on which such alteration, or act or exportation

is to be effected; however, this shall not apply to the cases prescribed by the Ministry of Education Ordinance.

2. In case the Commissioner of the Agency for Cultural Affairs deems it necessary for the protection of the important tangible folk-cultural property give necessary instructions with regard to the alteration of the existing state of such folk-cultural property or the act affecting the preservation of the said property or its exportation, for which report has been filed under the preceding paragraph.

**Article 56-14.** To the protection of the important tangible folk-cultural property the provisions of Articles 34-2 to 36 inclusive, Article 37 paragraphs 2 to 4 inclusive, and Articles 42, 46 and 47 shall apply *mutatis mutandis*.

(Opening to the Public of Important Tangible Folk-Cultural Property)

**Article 56-15.** In case any party other than the owner or the custodial body of the important tangible folk-cultural property, or local public body or any other juridical person appointed in accordance with the provision of Article 32-2 paragraph 1, applying *mutatis mutandis* under Article 56-12 (hereinafter the same in this Chapter and in Chapter VI), intends to open such important tangible folk-cultural property to the public at an exhibition or at any other public occasion to be held under his/her own auspices, such person shall report it to the Commissioner of the Agency for Cultural Affairs in writing at least thirty (30) days prior to the date of commencement of such public viewing, stating the matters prescribed by the Ministry of Education Ordinance; however, *ex post facto* notification within 20 days from the day after the final day of the public opening shall suffice in case such exhibition or other event is to be held under the auspices of a State agency other than the Commissioner of the Agency for Cultural Affairs or of a local public body at a museum or other similar institution which has previously been exempted of such notification requirements by the Commissioner of the Agency for Cultural Affairs (hereinafter in this paragraph referred to as "opening advance notification exempted institutions"), or when the person who has established an opening advance notification exempted institution holds such an event at the said opening advance notification exempted institution.

2. The provisions of Article 51 paragraphs 4 and 5 shall apply *mutatis mutandis* to the public viewing for which report has been filed under the text of the preceding paragraph.

**Article 56-16.** The provisions of Articles 47-2 to 52 inclusive shall apply *mutatis mutandis* to the opening to the public of the important tangible folk-cultural property.

(Investigation for Preservation of Important Tangible Folk-cultural Property and Succession to Rights and Obligations on Changes of Owner, etc.)

**Article 56-17.** To the investigation for the purpose of preservation of the important tangible folk-cultural property the provision of Article 54, and to the change of the owner of the important tangible folk-cultural property, to the appointment of a custodial body for such folk-cultural property or to the annulment of such appointment the provisions of Article 56 shall apply *mutatis mutandis*, respectively.

(Preservation of Important Intangible Folk-cultural Property)

**Article 56-18.** When the Commissioner of the Agency for Cultural Affairs deems it necessary for the preservation of the important intangible folk-cultural property, he/she may himself/herself undertake recording and other appropriate measures for the preservation thereof, and the State may aid a local public body or any other person deemed appropriate for taking care of its preservation by granting a subsidy to cover part of the expenses required for such preservation.

2. The provisions of Article 35 paragraphs 2 and 3 shall apply *mutatis mutandis* to the subsidization under the provision of the preceding paragraph.



(Opening to the Public of Records of Important Intangible Folk-cultural Property)

Article 56-19. The Commissioner of the Agency for Cultural Affairs may advise the owner of the records of the important intangible folk-cultural property to open the said records to the public.

2. To the case where the owner of the records of the important intangible folk-cultural property opens such records to the public, the provisions of Article 56-7 paragraph 3 shall apply *mutatis mutandis*.
3. The provision of Article 70-2 shall apply *mutatis mutandis* to the disposition to be made under the provision of paragraph 1 by the Commissioner of the Agency for Cultural Affairs or by the Board of Education of the To, Do, Fu or Ken (Prefectures), or by the designated city of Article 252-19-1 of the Local Public Body Law (Law No. 67 of 1947) or the core city of Article 252-22-1 of the same law (hereinafter referred to as "designated cities, etc."), to which the competence of the said Commissioner has been delegated.

(Suggestion or Advice on Preservation of Important Intangible Folk-cultural Property)

Article 56-20. The Commissioner of the Agency for Cultural Affairs may give suggestions or advice necessary for the preservation of important intangible folk-cultural property to a local public body or any other person who is deemed to be appropriate for taking care of its preservation.

(Recording, etc. of Intangible Folk-cultural Property Other Than Important Intangible Folk-cultural Property)

Article 56-21. The provisions of Article 56-9 shall apply *mutatis mutandis* to intangible folk-cultural property other than the important intangible folk-cultural property.

#### CHAPTER IV Buried Cultural Property

(Report, Instruction and Order on Excavation for Investigation)

Article 57. Any person who intends to excavate the land for the purpose of investigation of cultural properties which are buried underground (hereinafter referred to as "buried cultural property") shall report it to the Commissioner of the Agency for Cultural Affairs in writing at least thirty (30) days prior to the day on which the said excavation is to be commenced, stating the matters prescribed by the Ministry of Education Ordinance; however, this shall not apply to the cases prescribed by the Ministry of Education Ordinance.

2. The Commissioner of the Agency for Cultural Affairs may, when he/she deems it positively necessary for the protection of the buried cultural property, instruct necessary matters with regard to the excavation reported in accordance with the preceding paragraph and demand the submission of the reports thereof, or may prohibit the excavation or order its suspension or discontinuance.

(Report and Instruction on Excavation for Construction Working)

Article 57-2. In case any site well-known to contain buried cultural property such as shell mounds, ancient tombs or others (hereinafter referred to as "the well-known archaeological and/or historical subsoil") is to be dug up in the course of construction working or for any other purposes than the investigation of the buried cultural property, the provision of paragraph 1 of the preceding Article shall apply *mutatis mutandis*. (In this case, "thirty (30) days prior to" in the same paragraph shall read "sixty (60) days prior to.")

2. The Commissioner of the Agency for Cultural Affairs may, when he/she deems it positively necessary for the protection of buried cultural property, give necessary instructions with regard to the excavation reported under paragraph 1 of the preceding Article applying *mutatis mutandis* under the preceding paragraph.

(Special Provisions regarding Excavation Conducted by State Organs etc.)

Article 57-3. To the case where State organs, local public bodies, or juridical persons established by the State or local public bodies and prescribed by the Cabinet Order (hereinafter generically referred to as "State organs, etc." in this Article and in Article 57-6) intend to excavate the well-known archaeological and/or historical subsoil for the purpose provided for in paragraph 1 of the preceding Article, the provisions of the

said Article shall not apply, but when the said State organs, etc. formulate a plan of operation related to the said excavation, they shall inform in advance the Commissioner of the Agency for Cultural Affairs to that effect.

2. The Commissioner of the Agency for Cultural Affairs may, when he/she received the information under the preceding paragraph and found it positively necessary to do so for the protection of the buried cultural property, give notice to the State organ, etc. to the effect that the latter shall consult him/her regarding the formulation of the said plan of operation and its enforcement.
3. The State organ, etc. which have received the notice under the preceding paragraph shall consult the Commissioner of the Agency for Cultural Affairs on the formulation of the said plan of operation and its enforcement.
4. In case the Commissioner of the Agency for Cultural Affairs has received the information under paragraph 1, other than the cases under the preceding two paragraphs, he/she may give such advice as necessary for the protection of the buried cultural property regarding the enforcement of the plan of operation which has been informed of.
5. In the case under the preceding four paragraphs, if the said State organs, etc. are the heads of the Ministries of Agencies (to be taken as the heads of the Ministries of Agencies referred to in Article 4 paragraph 2 of the State Property Law (Law No. 73 of 1938); hereinafter the same) such notice, consultation or advice as provided for in these paragraphs shall go from the Minister of Education.

(Information to the Public of Archaeological and/or Historical Subsoil)

**Article 57-4.** The State and local public bodies shall attend to the complete documentation and other measures needed to keep the public fully and correctly informed of the well-known archaeological and/or historical subsoil.

2. The State may give guidance, advice or other necessary assistance regarding the measures taken by local public bodies under the preceding paragraph.

(Report on Discovery of Remains, Order for Suspension, etc.)

**Article 57-5.** When the owner or the possessor/occupant of the land has discovered what is recognizable as shell mound, swelling site, ancient tomb and other remains through the chance finds of unearthed articles, etc., excepting the case of discovery on the occasion of investigation exercised under the provision of Article 57 paragraph 1, he/she shall, without altering the existing state of such remains, report the fact without delay to the Commissioner of the Agency for Cultural Affairs in writing stating the matters prescribed by the Ministry of Education Ordinance. In case it is necessary to take emergency measures for the prevention of extraordinary disaster, however, he/she may alter the existing state of such remains within the normal limits of the emergency measures.

2. In case the Commissioner of the Agency for Cultural Affairs received the report under the preceding paragraph and recognizes the reported remains important, and deems it necessary to conduct an investigation for the purpose of their protection, he/she may order the owner or the possessor/occupant of the land to suspend or prohibit him/her to do within a prescribed term and area, the act which may lead to the alteration of their existing state. The term, however, shall not exceed three (3) months.
3. In case the Commissioner of the Agency for Cultural Affairs intends to issue the order under the preceding paragraph, he/she shall in advance hear the opinions of the local public body concerned.
4. The order under paragraph 2 shall be issued within one (1) month of the day of reporting under paragraph 1.
5. In the case under paragraph 2, when the investigation is not completed within the term prescribed in the same paragraph and is needed to be carried on, the Commissioner of the Agency for Cultural Affairs may extend once for all the term of investigation in regard to all or part of the area set out in the said order. The term of the same order, however, shall not exceed six (6) consecutive months including the original term specified under the same paragraph.

6. The term under paragraph 2 and the preceding paragraph shall be so calculated as to cover the period of time starting from the day on which the report under paragraph 1 is received until and including the day on which the order under paragraph 2 is issued.
7. The Commissioner of the Agency for Cultural Affairs may, even when the report under paragraph 1 has not been received, take measures as provided for in paragraphs 2 and 5.
8. Upon receipt of the report under paragraph 1, the Commissioner of the Agency for Cultural Affairs may, excepting the case where he/she has taken measures under paragraph 2, give instructions necessary for the protection of the said remains. Except for the case where he/she has taken measures under paragraph 2 in accordance with the provision of the preceding paragraph, the same shall apply to the case where he/she has not received the report under paragraph 1.
9. The State shall indemnify the person or persons who have suffered a loss owing to the order issued under paragraph 2, for the ordinary damage incidental thereto.
10. To the cases under the preceding paragraph the provisions of Article 41 paragraphs 2 to 4 inclusive shall apply *mutatis mutandis*.

(Special Provisions regarding Discovery of Remains by State Organs, etc.)

**Article 57-6.** When State organs, etc. have made a discovery as provided for in paragraph 1 of the preceding Article, the provisions of the same Article shall not apply, but, excepting the case where they have made a discovery on the occasion of investigation exercised under the provision of Article 57 paragraph 1 or Article 98-2 paragraph 1, they shall, without altering the existing state of the remains, inform the Commissioner of the Agency for Cultural Affairs to that effect without delay. In case they take emergency measures necessary for preventing extraordinary disasters, however, they may alter the existing state of the remains within the limits of such emergency measures.

2. In the cases where the Commissioner of the Agency for Cultural Affairs has received the information under the preceding paragraph, if he/she recognizes the remains informed as important and if he/she deems it necessary to investigate them for the purpose of their protection, he/she may notify the said State organs, etc. to the effect that they should apply to him/her for consultation regarding their investigation, preservation, etc.
3. The State organs, etc. which have received the notice under the preceding paragraph shall consult with the Commissioner of the Agency for Cultural Affairs.
4. In case the Commissioner of the Agency for Cultural Affairs has received the information under paragraph 1, excepting the cases under the preceding two paragraphs, he/she may give necessary advice for the protection of the said remains.
5. To the cases under the preceding four paragraphs, the provision of Article 57-3 paragraph 5 shall apply *mutatis mutandis*.

(Execution of Excavation by the Commissioner of the Agency for Cultural Affairs)

**Article 58.** The Commissioner of the Agency for Cultural Affairs may undertake the excavation of any land to investigate the buried cultural property for which investigation by the State is deemed necessary in view of its exceptionally high value from the point of view of history or science as well as for the technical difficulty it will entail.

2. In case the Commissioner of the Agency for Cultural Affairs intends to undertake excavation in accordance with the provision of the preceding paragraph, he/she shall in advance issue to the owner and the possessor/occupant by title of the land a writ stating the purpose and the method of excavation, the date of its commencement, and other necessary matters.
3. To the cases under paragraph 1, the provisions of Article 39 (including the provision of Article 32-2 paragraph 5 applying *mutatis mutandis* under paragraph 3 of the same Article) and Article 41 shall apply *mutatis mutandis*.

**Article 59.** When any cultural property has been discovered by the excavation carried out in accordance with paragraph 1 of the preceding Article, the Commissioner of the Agency for Cultural Affairs shall return the said property to its owner if the owner is known, but in case the owner is not traceable it shall suffice for him/her to notify the chief of the police station of the discovery, irrespective of the provision of Article 1 paragraph 1 of the Lost Property Law (Law No. 87 of 1899) applying *mutatis mutandis* under Article 13 of the same Law.

2. The chief of the police station shall, upon receiving the notice referred to in the preceding paragraph, issue promptly a public notice with regard to the said cultural property in accordance with the provision of Article 1 paragraph 2 of the Lost Property Law applying *mutatis mutandis* under Article 13 of the same Law.

(Presentation)

**Article 60.** In case an unearthened object placed as such before the chief of the police station in accordance with the provision of Article 1 paragraph 1 of the Lost Property Law applying *mutatis mutandis* under Article 13 of the same Law is recognizable as a cultural property, the said object shall be presented to the Commissioner of the Agency for Cultural Affairs without delay by the chief of the police station; however, this shall not apply where the owner thereof has been traced.

(Judgement)

**Article 61.** When an object has been presented to the Commissioner of the Agency for Cultural Affairs in accordance with the provision of the preceding Article, he/she shall judge whether the object is really a cultural property or not.

2. The Commissioner of the Agency for Cultural Affairs shall, upon finding the said object to be a cultural property, notify the chief of the police station thereof or shall, in a contrary case, send back the object to the chief of the police station.

(Delivery)

**Article 62.** When the owner of the cultural property mentioned in Article 59 paragraph 1 or paragraph 2 of the preceding Article has asked the chief of the police station to return the cultural property to himself/herself, the Commissioner of the Agency for Cultural Affairs shall deliver the object to the chief of the police station concerned.

(Reversion to National Treasury and Compensation)

**Article 63.** In case the owner of the cultural property mentioned in Article 59 paragraph 1 or Article 61 paragraph 2 is not traceable, the ownership thereof shall revert to the National Treasury. In this case the Commissioner of the Agency for Cultural Affairs shall so inform the finder of the said cultural property and the owner of the land where it was found, and shall pay them a compensation corresponding to the value of the object.

2. When the finder and the owner of the land referred to in the preceding paragraph are different persons, the compensation under the same paragraph shall be given them half and half.
3. To the cases under the preceding two paragraphs the provisions of Article 41 paragraphs 2 to 4 inclusive shall apply *mutatis mutandis*.

(Transfer, etc.)

**Article 64.** The Government may, unless it is necessary for the State to retain for itself the cultural property reverted to the National Treasury in accordance with the provision of paragraph 1 of the preceding Article for the purpose of its preservation or in view of its utility, transfer the said property to the finder thereof or to the owner of the land where it was found, within the limits of the value corresponding to the amount of the compensation to be received by the said person in accordance with the provisions of the preceding Article.

2. In the case mentioned in the preceding paragraph, the amount of money corresponding to the value of the transferred cultural property shall be deducted from the amount of the compensation provided for in the preceding Article.
3. The Government may, unless it is necessary for the State to retain for itself the cultural property reverted to the National Treasury in accordance with the provision of paragraph 1 of the preceding Article for the purpose of its preservation or in view of its utility, transfer the said property without consideration, or to assign it at a price lower than the current price, to the local public body which has jurisdiction over the land where the said cultural property was found, in case application is filed therefor.

(Application of the Lost Property Law)

Article 65. Unless otherwise provided for by this Law, the provision of Article 13 of the Lost Property Law shall apply to the buried cultural property.

Article 66 to Article 68 inclusive. Deleted.

## CHAPTER V Historic Sites, Places of Scenic Beauty and/or Natural Monuments

(Designation)

Article 69. The Minister of Education may designate important items of monuments as historic sites, places of scenic beauty, or natural monuments (hereinafter collectively referred to as "historic sites, places of scenic beauty and/or natural monument").

2. Of the historic sites, places of scenic beauty and/or natural monuments designated as such in accordance with the provision of the preceding paragraph, the Minister of Education may designate those which are particularly important as special historic sites, special places of scenic beauty, or special natural monuments (hereinafter collectively referred to as "special historic sites, places of scenic beauty and/or natural monument").
3. The designation under the preceding two paragraphs shall be made by an announcement in the Official Gazette and also by the issuance of a notice thereof to the owner and the possessor/occupant by title of the special historic site, place of scenic beauty and/or natural monument concerned or of the historic site, place of scenic beauty and/or natural monument concerned.
4. In case there are too many persons to be given the notice individually in accordance with the provision of the preceding paragraph, the Minister of Education may, in place of the notice provided for in the same paragraph, put up a notice of the matters to be communicated to them on the notice board of the public office or of any similar establishment of the city, town or village where the special historic site, place of scenic beauty and/or natural monument concerned or the historic site, place of scenic beauty and/or natural monument concerned is located. In this case the notice mentioned in the preceding paragraph shall be deemed as having reached the addressees thereof when two weeks have elapsed from the day on which the notice was first exhibited.
5. The designation under the provision of paragraph 1 or paragraph 2 shall come into effect as from the day of announcement in the Official Gazette under the provision of paragraph 3. However, for the owner or the possessor/occupant by title of the special historic site, place of scenic beauty and/or natural monument concerned or of the historic site, place of scenic beauty and/or natural monument concerned, it shall come into effect as from the time when the notice under the provision of paragraph 3 has reached him/her or when it is deemed to have reached him/her in accordance with the provision of the preceding paragraph.
6. The Minister of Education shall, in designating the historic site, place of scenic beauty and/or natural monument, ask the opinion of the Director General of the Environment Agency, if the area to be covered by the designation possesses a high value from the point of view of the protection of natural environment.

(Provisional Designation)

**Article 70.** Prior to the designation under the provision of paragraph 1 of the preceding Article, if the Board of Education of To, Do, Fu or Ken (Prefectures) deems it urgently necessary, it may make provisional designation of the historic site, place of scenic beauty and/or natural monument.

2. When the Board of Education of To, Do, Fu or Ken (Prefectures) has made the provisional designation under the provision of the preceding paragraph, it shall report the fact to the Minister of Education without delay
3. To the provisional designation under the provision of paragraph 1 the provisions of paragraphs 3 to 5 inclusive of the preceding Article shall apply *mutatis mutandis*.

(Respect for Ownership, etc. and Coordination with Other Public Interest)

**Article 70-2.** In making the designation under the provision of Article 69 paragraph 1 or paragraph 2 or in making the provisional designation under the provision of paragraph 1 of the preceding Article, the Minister of Education or the Board of Education of To, Do, Fu or Ken (Prefectures) shall respect in particular the ownership, the mining right and other property rights of the parties concerned, and at the same time pay attention to the coordination with land development and other kinds of public interests.

2. The Minister of Education or the Commissioner of the Agency for Cultural Affairs may, if it is deemed necessary for the protection and improvement of natural environment related to the place of scenic beauty or natural monument, express his/her opinions to the Director General of the Environment Agency.

(Annulment of Designation)

**Article 71.** When a special historic site, place of scenic beauty and/or natural monument, or a historic site, place of scenic beauty and/or natural monument has lost its value as such or when there is any other special reason, the Minister of Education or the Board of Education of To, Do, Fu or Ken (Prefectures) may annul the designation or the provisional designation thereof.

2. When the designation referred to in Article 69 paragraph 1 was made of such a historic site, place of scenic beauty and/or natural monument as was provisionally designated under the provision of Article 70 paragraph 1, or when no designation under the same provision was made of the same property within two years from the day of such provisional designation, the said provisional designation shall become null and void.
3. The Minister of Education may annul any provisional designation made under the provision of Article 70 paragraph 1, if he/she deems such designation inappropriate.
4. The provisions of Article 69 paragraphs 3 to 5 inclusive shall apply *mutatis mutandis* to the annulment of the designation or the provisional designation to be made under the provision of paragraph 1 or of the preceding paragraph.

(Custody and Restoration by Custodial Body)

**Article 71-2.** In the cases where the owner of the historic site, place of scenic beauty and/or natural monument does not exist or is not traceable, or where the custody thereof by its owner or by the person appointed in accordance with the provision of Article 74 paragraph 2 to be responsible for the conduct of its custody is obviously deemed extremely difficult or inappropriate, the Commissioner of the Agency for Cultural Affairs may appoint a suitable local public body or any other suitable juridical person and charge it with the conduct of custody and restoration necessary for the preservation of the historic site, place of scenic beauty and/or natural monument concerned (including the custody and restoration of such facilities, equipments and other matters under the ownership or in the custody of the owner of the historic site, place of scenic beauty and/or natural monument concerned as are necessary for the preservation thereof).

2. In order to make an appointment under the provision of the preceding paragraph, the Commissioner of the Agency for Cultural Affairs shall obtain in advance the consent of the local public body or any other juridical person to be appointed as such.

3. The appointment under the provision of paragraph 1 shall be made by an announcement in the Official Gazette, and also by the issuance of a notice thereof to the owner and the possessor/occupant by title of the historic site, place scenic beauty and/or natural monument concerned, as well as to the local public body or other juridical person to be appointed.
4. To the appointment under the provision of paragraph 1 the provisions of Article 69 paragraphs 4 and 5 shall apply *mutatis mutandis*.

**Article 71-3.** In the cases where the reasons referred to in paragraph 1 of the preceding Article have become extinct or where there is any other special reason, the Commissioner of the Agency for Cultural Affairs may annul the appointment of the custodial body.

2. To the annulment under the provision of the preceding paragraph the provisions of paragraph 3 of the preceding Article and Article 69 paragraphs 4 and 5 shall apply *mutatis mutandis*.

**Article 72.** The local public body and any other juridical person appointed under the provision of Article 71-2 paragraph 1 (hereinafter in this Chapter and Chapter VI referred to as the "custodial body") shall in accordance with the standards established by the Minister of Education Ordinance set up signs, explanation boards, landmarks, fences and other facilities necessary for the custody of the historic site, place of scenic beauty and/or natural monument concerned.

2. When, in regard to the land within the designated area of the historic site, place of scenic beauty and/or natural monument, there has been any change in the name of town, lot number, category or acreage, the custodial body concerned shall report it to the Commissioner of the Agency for Cultural Affairs in accordance with what may be provided for by the Ministry of Education Ordinance.
3. In case the custodial body undertakes restoration, it shall in advance hear the opinions of the owner (exclusive of the case where the owner is not traceable) and the possessor/occupant of the historic site, place of scenic beauty and/or natural monument concerned in regard to the method and the time of the restoration.
4. The owner or the possessor/occupant of the historic site, place of scenic beauty and/or natural monument shall not, without justifiable reasons, refuse, interfere with or evade the acts of custody or restoration, or the measures necessary for the execution of such acts, undertaken by the custodial body.

**Article 72-2.** The expenses required for the custody and the restoration undertaken by the custodial body shall be borne by the same body, unless otherwise provided for by this Law.

2. Notwithstanding the provision of the preceding paragraph, part of the expenses required for the custody or the restoration may be borne by the owner, in accordance with what may be agreed upon between the custodial body and the owner, within the limits of the material profit which the latter will enjoy as a result of the custody or the restoration conducted by the former.
3. The custodial body may collect admission-fees from the visitors to the historic site, place of scenic beauty and/or natural monument in its custody.

**Article 73.** As for the person or persons who have suffered a loss owing to the act of custody or restoration performed by the custodial body, the body concerned shall indemnify them for the ordinary damages incidental thereto.

2. The amount of the indemnity under the preceding paragraph shall be determined by the custodial body (or, when the custodial body is a local public body, the Board of Education of the same body).
3. As regards the amount of the indemnity under the provision of the preceding paragraph, the provision of Article 41 paragraph 3 shall apply *mutatis mutandis*.
4. In case of litigation under the provision of Article 41 paragraph 3 applying *mutatis mutandis* in the preceding paragraph, the custodial body shall be the dependent.

**Article 73-2.** To the custody undertaken by the custodial body the provisions of Article 30, Article 31 paragraph 1 and Article 33, to the custody and the restoration undertaken by the custodial body the provisions of Articles 35 and 47, and to the cases where the custodial body has been appointed or where such appointment has been annulled the provision of Article 56 paragraph 3 shall apply *mutatis mutandis*, respectively.

(Custody and Restoration by Owner)

**Article 74.** Excepting the case where a custodial body has been appointed, the owner of the historic site, place of scenic beauty and/or natural monument shall be responsible for the custody and the restoration thereof.

2. The owner who undertakes the custody of the historic site, place of scenic beauty and/or natural monument under the provision of the preceding paragraph may, if there is any special reason, appoint an appropriate person to be responsible on his/her behalf for the conduct of the custody of the same property (hereinafter in this Chapter and Chapter VI referred to as the "custodian"). In this case the provision of Article 31 paragraph 3 shall apply *mutatis mutandis*.

**Article 75.** To the custody by the owner the provisions of Article 30, Article 31 paragraph 1, Article 32, Article 33 and Article 72 paragraphs 1 and 2 (as for Article 72 paragraph 2, exclusive of the cases where the custodial body has been appointed), to the custody and the restoration by the owner the provisions of Article 35 and 47, to the succession to rights and obligations upon change of the owner the provision of Article 56 paragraph 1, and to the custody by the custodian the provisions of Article 30, Article 31 paragraph 1, Article 32 paragraph 3, Article 33, Article 47 paragraph 4 and Article 72 paragraph 2 shall apply *mutatis mutandis*, respectively.

(Order or Advice on Custody)

**Article 76.** In case the Commissioner of the Agency for Cultural Affairs concludes that a historic site, place of scenic beauty and/or natural monument is in danger of destruction, damage, decay or theft because of its inappropriate custody, he/she may order or advise the custodial body, the owner or the custodian thereof, with respect to the improvement of the method of custody, provision of facilities for preservation and any other measures necessary for its custody.

2. To the cases under the preceding paragraph the provisions of Article 36 paragraphs 2 and 3 shall apply *mutatis mutandis*.

(Order or Advice on Restoration)

**Article 77.** In the cases where a special historic site, place of scenic beauty and/or natural monument is damaged or in decay and the Commissioner of the Agency for Cultural Affairs deems it necessary for its preservation, he/she may give any necessary order or advice about its restoration to the custodial body or the owner thereof.

2. In the cases where a historic site, place of scenic beauty and/or natural monument, other than the special historic site, place of scenic beauty and/or natural monument, is damaged or in decay and the Commissioner of the Agency for Cultural Affairs deems it necessary for its preservation, he/she may give any necessary advice about its restoration to the custodial body or to the owner thereof.
3. The provisions of Article 37 paragraphs 3 and 4 shall apply *mutatis mutandis* to the cases under the preceding two paragraphs.

(Execution of Restoration, etc. of Special Historic Site, Place of Scenic Beauty and/or Natural Monument by the Commissioner of the Agency for Cultural Affairs)

**Article 78.** The Commissioner of the Agency for Cultural Affairs may himself/herself execute the restoration of the special historic site, place of scenic beauty and/or natural monument, or take preventive measures against its destruction, damage, decay or theft, in either of the following cases:

- (1) Where the custodial body, owner or custodian does not comply with the orders given in accordance with the provisions of the preceding two Articles;



(2) Where any special historic site, place of scenic beauty and/or natural monument is damaged or in decay, or in danger of destruction, damage, decay or theft, and where it is deemed inappropriate to make the custodial body, the owner or the custodian thereof execute its restoration or take preventive measures against its destruction, damage, decay or theft.

2. The provisions of Article 38 paragraph 2 and Articles 39 to 41 inclusive shall apply *mutatis mutandis* to the cases under the preceding paragraph.

(Reimbursement in case of Assignment of Historic Site, Place of Scenic Beauty and/or Natural Monument for which a Subsidy was granted, etc.)

**Article 79.** With respect to the historic site, place of scenic beauty and/or natural monument for which a subsidy has been granted by the State for its restoration or for the conduct of preventive measures against its destruction, damage, decay or theft in accordance with the provision of Article 35 paragraph 1 applying *mutatis mutandis* under Article 73-2 and Article 75, or for which whole or part of the expenses required for such action have been defrayed by the State in accordance with the provision of Article 36 paragraph 2 applying *mutatis mutandis* under Article 76 paragraph 2, in accordance with Article 37 paragraph 3 applying *mutatis mutandis* under Article 77 paragraph 3 or in accordance with Article 40 paragraph 1 applying *mutatis mutandis* under paragraph 2 of the preceding Article, the provision of Article 42 shall apply *mutatis mutandis*.

(Restriction on Alteration, etc. of Existing State and Order for Recovery to Original State)

**Article 80.** In case any person intends to do an act altering the existing state of a historic site, place of scenic beauty and/or natural monument or an act affecting the preservation thereof, he/she must obtain the permission of the Commissioner of the Agency for Cultural Affairs; however, this shall not apply to the case where such act as altering the existing state is merely a measure for maintaining the existing state of the property or an emergency measure necessary for the prevention of extraordinary disasters or where the influence of the act which may affect its preservation is only negligible.

2. The coverage of the measures for maintaining the existing state mentioned in the proviso to the preceding paragraph shall be established by the Ministry of Education Ordinance.
3. The provision of Article 43 paragraph 3 shall apply *mutatis mutandis* to the issuance of permission provided for in paragraph 1, and that of Article 43 paragraph 4 to the person who has obtained such permission.
4. The provision of Article 70-2 shall apply *mutatis mutandis* to the disposition to be made under the provision of paragraph 1 by the Commissioner of the Agency for Cultural Affairs or by the Board of Education of To, Do, Fu or Ken (Prefectures) to which the competence of the said Commissioner has been delegated.
5. The State shall indemnify the person who has suffered a loss owing to the fact that he/she failed to receive the permission under paragraph 1 or that the permission given was attached with conditions under Article 43 paragraph 3 applying *mutatis mutandis* under paragraph 3, for the ordinary damage incidental thereto.
6. The provisions of Article 41 paragraphs 2 to 4 inclusive shall apply *mutatis mutandis* to the case under the preceding paragraph.
7. In case any person has done an act altering the existing state or affecting the preservation of a historic site, place of scenic beauty and/or natural monument without obtaining the permission under the provision of paragraph 1 or without complying with the conditions of the permission given under Article 43 paragraph 3 applying *mutatis mutandis* under paragraph 3, the Commissioner of the Agency for Cultural Affairs may order him/her to recover its original state. In this case the Commissioner of the Agency for Cultural Affairs may give necessary instructions regarding such recovery.

(Notice by the Administrative Agency Concerned)

**Article 80-2.** In case of an act for which permission should be obtained under the provision of paragraph 1 of the preceding Article, and the conduct of which is subjected to permission, authorization or other disposition prescribed by the Cabinet Order under the provisions of other laws or orders, the administrative agency

which has the competence for such dispositions under the said other laws or orders, or the person to whom the said competence has been delegated, shall in making the disposition give a notice to the Commissioner of the Agency for Cultural Affairs (or to the Board of Education of the To, Do, Fu or Ken (Prefectures) or the designated city, etc., when the competence for permission under the provision of paragraph 1 of the same Article is delegated thereto) in accordance with what may be provided for by the Cabinet Order.

(Report, etc. on Restoration)

**Article 80-3.** In case a historic site, place of scenic beauty and/or natural monument is to be restored, the custodial body or the owner thereof shall report it to the Commissioner of the Agency for Cultural Affairs at least thirty (30) days prior to the date of commencement of such work, in accordance with what may be prescribed by the Ministry of Education Ordinance; this shall not apply, however, to the cases where the permission must be obtained in accordance with the provision of Article 80 paragraph 1 and to those other cases prescribed by the Ministry of Education Ordinance.

2. In case the Commissioner of the Agency for Cultural Affairs deems it necessary for the protection of the historic site, place of scenic beauty and/or natural monument, he/she may give technical guidance and advice in regard to the restoration of the historic site, place of scenic beauty and/or natural monument reported in accordance with the preceding paragraph.

(Integrity of Surroundings)

**Article 81.** The Commissioner of the Agency for Cultural Affairs may, if he/she deems it necessary for ensuring the preservation of the historic site, place of scenic beauty and/or natural monument, restrict or prohibit certain kinds of act within a prescribed area or may order the provision of necessary facilities in such area.

2. The State shall indemnify the person or persons, who have suffered a loss owing to the disposition mentioned in the preceding paragraph, for the ordinary damage incidental thereto.
3. To the person who has disobeyed the restriction or prohibition provided for in paragraph 1 the provision of Article 80 paragraph 7, and to the case under the preceding paragraph the provisions of Article 41 paragraphs 2 to 4 inclusive shall apply *mutatis mutandis*, respectively.

(Subsidy for Purchase by Custodial Body)

**Article 81-2.** In case a local public body or other juridical person that is a custodial body deems it positively necessary to purchase the land or buildings or other fixtures to land involved in the designation as historic site, place of scenic beauty and/or natural monument, for the purpose of ensuring the preservation of such designated property which is under its custody, the State may grant a subsidy to cover part of the expenses required for the purchase.

2. To the cases under the preceding paragraph the provisions of Article 35 paragraphs 2 and 3 and Article 42 shall apply *mutatis mutandis*.

(Investigation for the Purpose of Preservation)

**Article 82.** The Commissioner of the Agency for Cultural Affairs may, when he/she deems it necessary, ask the custodial body, the owner or the custodian to file reports on the existing state of the historic site, place of scenic beauty and/or natural monument, or on the conditions of its custody, of its restoration or of the preservation of the integrity of its surroundings.

**Article 83.** In any of the following cases, when the Commissioner of the Agency for Cultural Affairs is unable to confirm the conditions of a historic site, place of scenic beauty and/or natural monument in spite of all the information given in the report filed under the preceding Article, and when there appears to be no alternative way for the confirmation thereof, he/she may appoint a person or persons who are to conduct investigation, and cause them to enter the land where the historic site, place of scenic beauty and/or natural monument to be investigated exists or the area adjoining and carry out an investigation on the spot as to its existing state or the conditions of its custody, of its restoration or of the preservation of the integrity of its

surroundings, as well as excavation, removal of obstacles or any other measures necessary for the purpose of such investigation; however, he/she shall not cause the said person or persons to take such steps as may result in considerable damage to the owner or the possessor/occupant of such land or to any other interested parties:

- (1) Where application has been filed for approval of alteration of the existing state or of actions affecting the preservation of a historic site, place of scenic beauty and/or natural monument;
  - (2) Where a historic site, place of scenic beauty and/or natural monument is damaged or in decay;
  - (3) Where a historic site, place of scenic beauty and/or natural monument is in danger of destruction, damage, decay or theft;
  - (4) Where special circumstances necessitate the re-investigation of the value of a special historic site, place of scenic beauty and/or natural monument or of a historic site, place of scenic beauty and/or natural monument as such.
2. The State shall indemnify the person or persons who have suffered a loss owing to the investigation or measures carried out in accordance with the provision of the preceding paragraph, for the ordinary damage incidental thereto.
  3. The provision of Article 55 paragraph 2 shall apply *mutatis mutandis* to the cases where investigation is conducted by entering the land in accordance with the provision of paragraph 1, and the provisions of Article 41 paragraphs 2 to 4 inclusive to the cases under the preceding paragraph, respectively.

## CHAPTER V-2 Preservation Districts for Groups of Historic Buildings

(Preservation Districts for Groups of Historic Buildings)

**Article 83-2.** The term "preservation districts for groups of historic buildings" in this Chapter shall mean the districts determined by cities, towns or villages in accordance with the provisions of paragraph 1 or 2 of the following Article, for the purpose of preserving groups of historic buildings and the environs which build up a value in combination with such buildings.

(Determination and Protection of Preservation Districts for Groups of Historic Buildings)

**Article 83-3.** Municipalities may establish the preservation districts for groups of historic buildings in their city plans within the city planning areas designated under the provision of Article 5 of the City Planning Law (Law No. 100 of 1968). In this case the municipalities may, for the purpose of ensuring the preservation of the said districts, determine by their own regulations necessary matter concerning the control on the alteration of the existing state in view of the standards prescribed by the Cabinet Order, and also determine any other necessary measures for the said preservation.

2. The municipalities may in the districts other than the city planning areas under the preceding paragraph, establish the preservation districts for groups of historic buildings in accordance with their own regulations. In this case, the provision of the latter part of the preceding paragraph shall apply *mutatis mutandis*.
3. In case the governor of a municipality approves the city plan in regard to the preservation districts for groups of historic buildings under paragraph 1 in accordance with the City Planning Law, he/she shall in advance hear the opinions of the Board of Education of To, Do, Fu or Ken (Prefectures) concerned.
4. In case the municipalities have established or cancelled the preservation districts for groups of historic buildings, or has enacted, revised or abolished their own regulations, they shall report the fact to the Commissioner of the Agency for Cultural Affairs.
5. The Commissioner of the Agency for Cultural Affairs or the Board of Education of To, Do, Fu or Ken (Prefectures) may give municipalities guidance or advice necessary for the preservation of the preservation districts for groups of historic buildings.

(Classification of Important Preservation Districts for Group of Historic Buildings)

**Article 83-4.** The Minister of Education may, according to the application filed by municipalities, classify whole or part of the preservation districts for groups of historic buildings which possess an especially high value in and for this country as important preservation districts for groups of historic buildings.

2. The classification under the provision of the preceding paragraph shall be made by an announcement in the Official Gazette, and also by the issuance of a notice thereof to the municipalities which have filed the application.

(Annulment of Classification)

**Article 83-5.** When any important preservation district for groups of historic buildings has lost its value as such, or when there is any other special reason, the Minister of Education may annul the classification thereof.

2. To the cases under the preceding paragraph the provision of paragraph 2 of the preceding Article shall apply *mutatis mutandis*.

(Subsidy for Custody, etc.)

**Article 83-6.** The State may, for the preservation of the important preservation district for groups of historic buildings, grant a subsidy to cover part of the expenses required for such measures as may be taken by municipalities for the custody, repair, enhancement, or restoration of the buildings and such objects as are deemed positively necessary for the preservation of their environs which are inseparably combined with the groups of historic buildings within the said district.

#### CHAPTER V-3 Protection of Traditional Techniques for Conservation of Cultural Properties

(Designation of Traditional Conservation Technique, etc.)

**Article 83-7.** The Minister of Education may designate as traditional conservation techniques those traditional techniques or craftsmanship which is indispensable for the conservation of cultural properties and must be preserved with positive measures.

2. In making the designation under the provision of the preceding paragraph, the Minister of Education shall recognize the holder or holders of the traditional conservation technique concerned who represent the high standard of such technique, or its preservation body or bodies (including juridical persons) which primarily aim at the preservation of such technique and have their representatives or managers established by their own statutes; hereinafter the same).
3. The recognition relative to a particular designated traditional conservation technique under the provisions of the preceding paragraph may cover both the holders and the preservation bodies.
4. To the designation under the provision of paragraph 1 and the recognition under the provisions of the preceding two paragraphs the provisions of Article 56-3 paragraphs 3 to 5 inclusive shall apply *mutatis mutandis*.

(Annulment of Designation, etc.)

**Article 83-8.** The Minister of Education may, when it is no longer necessary to take positive measures for the preservation of a designated traditional conservation technique or when there is any other special reason, annul the designation concerned.

2. In case a holder is deemed to have become inadequate to maintain such title for his/her mental or physical reasons, or in case a preservation body is deemed to have become inadequate to maintain such title or when there is any other special reason, the Minister of Education may annul his/her or its recognition as holder or preservation body, respectively.
3. The provision of Article 56-4 paragraph 3 shall apply *mutatis mutandis* to the cases under the preceding two paragraphs.

4. In case the recognition under paragraph 2 of the preceding Article has been made only of the holders and all of them have died, or in case the recognition under the same paragraph has been made only of the holding bodies and all of them have been dissolved (including their extinction; hereinafter the same in this paragraph), or in case the said recognition has covered both the holders and the preservation bodies and all of the holders have died and all of the preservation bodies have also been dissolved, the designation as the designated traditional conservation technique shall be deemed to have been annulled. In such cases, the Minister of Education shall announce the fact in the Official Gazette.

(Change of Name of Holder, etc.)

**Article 83-9.** The provision of Article 56-5 shall *mutatis mutandis* to the holder and the preservation body. In this case, "the representative" in the latter part of the same Article shall read " the representative or the manager."

(Preservation of Designated Traditional Conservation Technique)

**Article 83-10.** When it is deemed necessary to do so for the preservation of the designated traditional conservation technique, the Commissioner of the Agency for Cultural Affairs may himself/herself take record of technique, or take any appropriate measures for what is deemed necessary for the preservation thereof, including training of successors in the art.

(Opening to the Public of Records of Designated Traditional Conservation Technique)

**Article 83-11.** The provisions of Article 56-19 shall apply *mutatis mutandis* to the owner of the records of the designated traditional conservation technique.

(Assistance for Preservation of Designated Traditional Conservation Technique)

**Article 83-12.** The State may give guidance, advice or other assistance which is deemed necessary to the holder or preservation body of the designated traditional conservation technique, or to those who are considered appropriate for undertaking its preservation, such as a local public body.

#### CHAPTER V-4 The Council for the Protection of Cultural Properties

(Establishment and Functions)

**Article 84.** The Ministry of Education shall have the Council for the Protection of Cultural Properties.

2. The Council for the Protection of Cultural Properties (hereinafter referred to in this Chapter as the "Council") shall, when consulted by the Minister of Education or the Commissioner of the Agency for Cultural Affairs, investigate and deliberate on important matters concerning the preservation and utilization of cultural properties, as well as make proposals to the Minister of Education or the Commissioner of the Agency for Cultural Affairs concerning such matters.

(Consultation with the Council)

**Article 84-2.** The Minister of Education shall in advance consult the Council with reference to the following matters:

- (1) Designation of national treasures or important cultural properties, and annulment of such designation;
- (1-2) Registration of registered tangible cultural properties, and annulment of such registrations (excluding annulment of registrations under the provision of Article 56-2-3 paragraph 1);
- (2) Designation of important intangible cultural properties, and annulment of such designations;
- (3) Recognition of holders or holding bodies of important intangible cultural properties, and annulment of such recognition;
- (4) Designation of important tangible folk-cultural properties or important intangible folk-cultural properties and annulment of such designation;

- (5) Designation of special historic sites, places of scenic beauty and/or natural monuments, or of historic sites, places of scenic beauty and/or natural monument, and annulment of such designation;
  - (6) Annulment of the provisional designation of historic sites, places of scenic beauty and/or natural monuments;
  - (7) Classification to important preservation districts for groups of historic buildings, and annulment of such classification;
  - (8) Designation of traditional conservation technique, and annulment of such designation;
  - (9) Recognition of holders or preservation bodies of designated traditional conservation techniques, and annulment of such recognition.
2. The Commissioner of the Agency for Cultural Affairs shall in advance consult the Council with reference to the following matters:
- (1) Orders concerning the custody of important cultural properties or the repair of national treasures;
  - (2) Execution by the Commissioner of the Agency for Cultural Affairs of the repair of national treasures or of preventive measures against their destruction, damage or theft;
  - (3) Permission for alteration of the existing state or acts affecting the preservation of important cultural properties;
  - (4) Restriction or prohibition of acts, or orders for the provision of necessary facilities, as may be required for the maintenance of the integrity of surroundings of important cultural properties.
  - (5) Purchase of important cultural properties by the State;
  - (6) Selection of intangible cultural properties other than important intangible cultural properties, of which the Commissioner of the Agency for Cultural Affairs should prepare records or for the recording, etc. of which subsidies should be granted;
  - (7) Orders concerning the custody of important tangible folk-cultural properties;
  - (8) Purchase of important tangible folk-cultural properties;
  - (9) Selection of intangible folk-cultural properties other than important intangible folk-cultural properties, of which the Commissioner of the Agency for Cultural Affairs should prepare records or for the recording, etc. of which subsidies should be granted;
  - (9-2) Extension of the term of orders for suspension or for prohibition of act altering the existing state of remains;
  - (10) Execution of excavation by the Commissioner of the Agency for cultural Affairs for the purpose of investigating buried cultural properties;
  - (11) Orders concerning the custody of historic sites, places of scenic beauty and/or natural monuments, or concerning the restoration of special historic sites, places of scenic beauty and/or natural monuments;
  - (12) Execution by the Commissioner of the Agency for Cultural Affairs of restoration or of preventive measures against destruction, damage, decay or theft of special historic sites, places of scenic beauty and/or natural monuments;
  - (13) Permission for alteration of the existing state of historic sites, places of scenic beauty and/or natural monuments or for acts affecting the preservation thereof;
  - (14) Restriction or prohibition of acts, or orders for provision of necessary facilities, as may be required for the maintenance of the integrity of surroundings of historic sites, places of scenic beauty and/or natural monuments;
  - (15) Orders for the recovery of original state of historic sites, places of scenic beauty and/or natural monuments, to be issued in the cases where any acts have been made without permission for alteration of the existing state or for acts affecting the preservation thereof, or not in compliance with the conditions of such permission, or where the restriction or prohibition of acts for maintenance of the integrity of their surroundings has been disobeyed;
  - (16) Delegation to the Boards of Education of To, Do, Fu or Ken (Prefectures) or of the designated city, etc. of the competence to give permission for alteration of the existing state of important cultural properties or for acts affecting the preservation thereof, or for alteration of the existing state of historic sites, places of

scenic beauty and/or natural monuments or for acts affecting the preservation thereof, or to cancel such permission.

(Members, etc.)

**Article 84-3.** The Council shall be composed of five (5) members who have been appointed by the Minister of Education, with the approval of the Cabinet, from among those who have wide and eminent views on and knowledge of culture.

2. When it is necessary for the investigation of and deliberation on professional matters, the Council may have an expert member or members and a temporary expert member or members.

(Transfer to Cabinet Order)

**Article 84-4.** In addition to what have been provided for in this Chapter, matters relating to the internal organization of the Council, affairs under its jurisdiction, its members and other personnel shall be determined by the Cabinet Order.

## CHAPTER VI Additional Provisions

### Section 1. Public Hearings and Protests

(Special Cases of Public Hearings)

**Article 85.** When the Commissioner of the Agency for Cultural Affairs intends to make dispositions or take measures mentioned in the following items, he/she shall hold a public hearing, regardless of the classification of the procedures for the voicing of opinions stipulated in Article 13, paragraph 1 of the Administrative Procedures Law (Law No. 88 of 1993).

- (1) Restriction, prohibition or order to be issued to particular persons under the provisions of Article 45 paragraph 1 or Article 81 paragraph 1;
  - (2) Order for discontinuance of public viewing under the provisions of Article 51 paragraph 5 (including cases where Article 51-2 [including cases where Article 56-16 applies *mutatis mutandis*], Article 56-15 paragraph 2 and Article 56-16 apply *mutatis mutandis*);
  - (3) Prohibition of or order for discontinuance of excavation under the provision of Article 57 paragraph 2;
  - (4) Order for suspension or for prohibition under Article 57-5 paragraph 2 for the conduct of investigation mentioned in the same paragraph or extension of the term of such order under the provision of paragraph 5 of the same Article;
  - (5) Order for restoration to the status quo under the stipulations of Article 80 paragraph 7 (including cases where Article 81 paragraph 3 applies *mutatis mutandis*);
2. When the Commissioner of the Agency for Cultural Affairs intends to hold a public hearing under the preceding paragraph or a public hearing related to the cancellation of permission under the provisions of Article 43 paragraph 4 (including cases where Article 80 paragraph 3 applies *mutatis mutandis*) or those of Article 53 paragraph 4, he/she shall give notice in accordance with the provision of Article 15 paragraph 1 of the Administrative Procedures Law, and at the same time shall make a public announcement concerning the substance of the disposition and the date and place of the public hearing, at least ten (10) days in advance.
  3. Deliberations on the date for the public hearing under the preceding paragraph shall be held publicly.

(Hearing of Opinions)

**Article 85-2.** When the Commissioner of the Agency for Cultural Affairs intends to make dispositions or take measures mentioned in the following items, he/she shall hold a public hearing by the requesting the attendance of the parties concerned or their proxies:

- (1) Execution of repairs, restoration or measures under the provision of Article 38 paragraph 1 or Article 78 paragraph 1;

- (2) Execution of an invasive inspection or measures necessary for inspection under the provisions of Article 55 paragraph 1 or Article 83 paragraph 1;
- (3) Execution of excavation under the provisions of Article 58 paragraph 1.
2. When the Commissioner of the Agency for Cultural Affairs intends to hold a public hearing under the preceding paragraph, he/she shall notify the parties concerned of the reasons for the disposition or measure to be made or taken under the relevant items of the same paragraph, the substance of each disposition or measure, and the date and place of the public hearing, at least ten (10) days in advance, and at the same time shall make a public announcement of such substance of disposition or measure and of the date and place of the said public hearing.
3. At the public hearing under paragraph 1, the parties concerned or their proxies may express opinions or give explanations, and produce evidences, in behalf of themselves or of the principals.
4. In case the parties concerned or their proxies failed to attend the public hearing under paragraph 1 without a justifiable reason, the Commissioner of the Agency for Cultural Affairs may effect the disposition or measure mentioned in each of the items of paragraph 1 without holding any public hearing.

(Public Hearing in Case of Procedures for Protest)

**Article 85-3.** In case a protest has been filed with the Commissioner of the Agency for Cultural Affairs against either of the dispositions mentioned below, except in cases where the protest is to be rejected, he/she shall, within thirty (30) days of receiving the written protest, open a public hearing, requesting the attendance of the protestant(s) and participants, or any proxies thereof:

- (1) Permission or rejection of demand for permission for the alteration of existing state or for an act affecting the preservation thereof under the provision of Article 43 paragraph 1 or Article 80 paragraph 1;
- (2) Appointment of the custodial body under the provision of Article 71-2 paragraph 1.
2. In holding a public hearing, the Commissioner of the Agency for Cultural Affairs shall notify the protestant(s) and any participants of the date and place of the public hearing at least ten (10) days in advance, while making at the same time a public announcement of the gist of the case and of the date and place of the said public hearing.

(Participation)

**Article 85-4.** In addition to the protestant(s), participant(s) and any proxies thereof, any interested party to the disposition in question who desires to express his/her opinion on the occasion of the public hereing under paragraph 1 of the preceding Article shall make written application for permission to the Commissioner of the Agency for Cultural Affairs, stating the matters prescribed by the Ministry of Education Ordinance.

(Presentation of Evidence, etc.)

**Article 85-5.** On the occasion of the public hearing opened under the provision of Article 85-3 paragraph 1, the protestant(s), the participant(s) and the person(s) participating in the said ppublic hearing in accordance with the provision of the preceding Article, or the proxies of thereof, must be given the opportunity to present evidences and to express opinions in regard to the case concerned.

(Consultation, etc. preceding Final Decision)

**Article 85-6.** When the case of the protest involves certain coordination with the mining or stone-quarrying industry, the Commissioner of the Agency for Cultural Affairs shall, except in the case of rejecting the protest, give his/her final decision after consulting with the Environmental Disputes Coordination Commission.

2. Heads of respective administrative organs concerned may give their opinions in regard to the case of the protest.



(Procedures)

**Article 85-7.** Other than those provided for in the preceding four Articles and in the Administrative Appeal Law (Law No. 160 of 1962), procedures with respect to a protest shall be prescribed by the Ministry of Education Ordinance.

(Relation between Protest and Lawsuit)

**Article 85-8.** A lawsuit for cancellation of such disposition as mentioned in each of the items of Article 85-3 paragraph 1 shall not be instituted unless decision is reached as to the protest raised against the disposition in question.

## Section 2. Special Provisions regarding the State

(Special Provisions regarding the State in Connection with Important Cultural Properties, etc.)

**Article 86.** In applying the provisions of the present Law to the State or State organs, special provisions contained in this Section shall have the priority.

**Article 87.** When the important cultural property, important folk-cultural property or historic site, place of scenic beauty and/or natural monument is the State property which is provided for by the State Property Law (Law No. 73 of 1948), it shall be subjected to the custody of the Minister of Education; however, when any such property is the administrative property prescribed in Article 3 paragraph 2 of the same Law in the custody of a person other than the Minister of Education, or when there is any special reason to place such a property in the custody of a person other than the Minister of Education, the question whether the said property should be placed in the custody of the head of the Ministry or Agency concerned or in the custody of the Minister of Education shall be determined through the consultation of the Minister of Education, the head of the Ministry or Agency concerned and the Minister of Finance.

**Article 87-2.** When the transfer of jurisdiction or administrative control is to be made between the accounting units belonging to different jurisdictions respecting an important cultural property, important tangible folk-cultural property, or historic site, place of scenic beauty and/or natural monument, for the purpose of placing the said property in the custody of the Minister of Education in accordance with the provision of the preceding Article, it shall be so arranged without compensation notwithstanding the provision of Article 15 of the State Property Law.

**Article 88.** When any tangible cultural property or tangible folk-cultural property belonging to the State has been designated as national treasure or important cultural property or important tangible folk-cultural property, the notice or the certificate of designation to be issued to its owner under the provision of Article 28 paragraph 1 or paragraph 3 (including the cases where the same provisions apply *mutatis mutandis* under Article 56-10 paragraph 2) shall be issued to the head of the Ministry or Agency in charge of the custody of the tangible cultural property or the tangible folk-cultural property concerned.

In this case, the head of the Ministry or Agency who has received the certificate of designation of national treasure shall send back to the Minister of Education without delay the certificate of designation of important cultural property previously issued for the same property that has now been designated as national treasure.

2. When the designation of a national treasure, important cultural property or important tangible folk-cultural property belonging to the State has been annulled, the notice or the certificate of designation to its owner under the provision of Article 29 paragraph 2 (including the cases where the same applies *mutatis mutandis* under Article 56-11 paragraph 2) or paragraph 5 shall be issued to the head of the Ministry or Agency in charge of the custody of such national treasure, important cultural property or important tangible folk-cultural property. In this case, the head of the Ministry or Agency concerned shall send back the certificate of designation to the Minister of Education without delay.

3. When the property owned or occupied by the State has been designated or provisionally designated as special historic site, place of scenic beauty and/or natural monument or as historic site, place of scenic beauty and/or natural monument, or when such designation or provisional designation has been annulled, the notice to be issued to the owner or the possessor/occupant under the provision of Article 69 paragraph 3 (including the cases where the same applies *mutatis mutandis* under Article 70 paragraph 3 and Article 71 paragraph 4) shall be issued to the head of the Ministry or Agency in charge of the custody of such property.

**Article 89.** The head of the Ministry or Agency in charge of the custody of an important cultural property, important tangible folk-cultural property or historic site, place of scenic beauty and/or natural monument shall exercise the custody of such property in accordance with this Law, and with the Ministry of Education Ordinance and at the advice of the Commissioner of the Agency for Cultural Affairs, issued or given thereunder.

**Article 90.** The head of the Ministry or Agency concerned shall give a notice to the Commissioner of the Agency for Cultural Affairs through the Minister of Education in any of the following cases:

- (1) Where any important cultural property, important tangible folk-cultural property, or historic site, place of scenic beauty and/or natural monument has been newly acquired;
- (2) Where there has been the transfer of jurisdiction or of administrative control respecting any important cultural property, important tangible folk-cultural property, or historic site, place of scenic beauty and/or natural monument;
- (3) Where any important cultural property, important tangible folk-cultural property, or historic site, place of scenic beauty and/or natural monument, under the jurisdiction of the Ministry or Agency concerned has been entirely or partially destroyed, damaged, or decayed, or has been lost or stolen;
- (4) Where the location of any important cultural property or important tangible folk-cultural property, under the jurisdiction of the Ministry or Agency concerned, is to be changed;
- (5) Where any important cultural property or historic site, place of scenic beauty and/or natural monument, under the jurisdiction of the Ministry or Agency concerned, is to be repaired or restored (excluding the case where consent of the Commissioner of the Agency for Cultural Affairs must be applied for in accordance with the provision of a paragraph 1 item (1) of the following Article, or any other cases provided for by the Ministry of Education Ordinance);
- (6) Where the existing state of any important tangible folk-cultural property under the jurisdiction of the Ministry or Agency concerned is to be changed or an act affecting the preservation thereof is to be taken, or where such property is to be exported;
- (7) Where in regard to the land within the designated area of any historic site, place of scenic beauty and/or natural monument under the jurisdiction of the Ministry or Agency concerned, there has been a change in the name of town, lot number, category or acreage.

2. In cases where notices are to be filed under the respective items of the preceding paragraph, the following provision shall apply *mutatis mutandis*: the provision of Article 32 paragraph 1 and those of Article 56-12 and Article 75 under which Article 32 paragraph 1 applies *mutatis mutandis*, when notices are to be filed under items (1) and (2) of the preceding paragraph; the provision of Article 33 and those of Article 56-12 and Article 75 under which Article 33 applies *mutatis mutandis*, when notices are to be filed under item (3) of the preceding paragraph; the provision of Article 34 and that of Article 56-12 under which Article 34 applies *mutatis mutandis*, when notices are to be filed under item (4) of the preceding paragraph; the provisions of Article 43-2 paragraph 1 and Article 80-3 paragraph 1 when notices are to be filed under item (5) of the preceding paragraph; the provision of Article 56-13 paragraph 1, when notices are to be filed under item (6) of the preceding paragraph; and the provision of Article 72 paragraph 2, when notices are to be filed under item (7) of the preceding paragraph.
3. The Commissioner of the Agency for Cultural Affairs may give necessary advice on the matters notified under paragraph 1 item (5) or (6).

**Article 91.** The head of the Ministry or Agency concerned shall obtain in advance the consent of the Commissioner of the Agency for Cultural Affairs through the Minister of Education, in any of the following cases:

- (1) Where he/she intends to alter the existing state of the important cultural property or of the historic site, place of scenic beauty and/or natural monument, or to do any act affecting the preservation thereof;
  - (2) Where he/she intends to export any important cultural property under his/her jurisdiction;
  - (3) Where he/she intends to loan, exchange, sell, transfer, or otherwise dispose of the important cultural property, important tangible folk-cultural property or historic site, place of scenic beauty and/or natural monument under his/her jurisdiction.
2. When any of the State organs other than the head of the Ministry or Agency intends to alter the existing state of the important cultural property or of the historic site, place of scenic beauty and/or natural monument, or to do any act affecting the preservation thereof it shall obtain in advance the consent of the Commissioner of the Agency for Cultural Affairs.
3. In the case coming under paragraph 1 item (1) and the preceding paragraph, the proviso to Article 43 paragraph 1 and the provision of paragraph 2 of the same Article, as well as the proviso to Article 80 paragraph 1 and the provision of paragraph 2 of the same Article shall apply *mutatis mutandis*.
4. The Commissioner of the Agency for Cultural Affairs shall, in giving consent regarding the steps provided for in paragraph 1 item (1) or paragraph 2, give necessary advice thereon as a condition to such consent.
5. The head of the Ministry or Agency concerned or any other State organ shall duly respect the advice of the Commissioner of the Agency for Cultural Affairs given under the provision of the preceding paragraph.

**Article 92.** The Commissioner of the Agency for Cultural Affairs may, when he/she deems it necessary, give appropriate advice to the head of the Ministry or Agency through the Minister of Education, respecting the following matters:

- (1) Method of custody of the important cultural property, important tangible folk-cultural property, or historic site, place of scenic beauty and/or natural monument, under his/her jurisdiction;
  - (2) Repair or restoration or preventive measures against destruction, damage, decay or theft of the important cultural property, important tangible folk-cultural property, or historic site, place of scenic beauty and/or natural monument, under his/her jurisdiction;
  - (3) Provision of facilities necessary for the preservation of the integrity of surroundings of the important cultural property or of the historic site, place of scenic beauty and/or natural monument;
  - (4) Display or opening to the public of the important cultural property or the important tangible folk-cultural property under his/her jurisdiction.
2. With respect to the advice under the preceding paragraph, the provision of paragraph 5 of the preceding Article shall apply *mutatis mutandis*.
3. With respect to the share of expenses required for the repairs, restoration or measures mentioned in paragraph 1 item (2) or for the provision of facilities mentioned in item (3) of the same paragraph to be undertaken or made on the advice of the Commissioner of the Agency for Cultural Affairs given under the same paragraph, the Minister of Education and the head of the Ministry or Agency concerned shall decide by consultation between themselves.

**Article 93.** In any of the cases given in the following items, the Commissioner of the Agency for Cultural Affairs may himself/herself conduct repairs or restoration, or take preventive measures against destruction, damage, decay or theft, respecting the national treasure or the special historic site, place of scenic beauty and/or natural monument belonging to the State. If, in this case, however, the cultural property in question is under the jurisdiction of the head of the Ministry or Agency, other than the Minister of Education, the Commissioner of the Agency for Cultural Affairs shall consult in advance, through the Minister of Education, the head of the Ministry or Agency taking custody of the said property respecting the substance of the repairs, restoration or measures, the date of commencement of the work, and other necessary matters; and

if the said property is under the jurisdiction of the Minister of Education, the Commissioner of the Agency for Cultural Affairs shall secure his/her approval, unless otherwise regulated by the Minister of Education.

(1) Where the head of the Ministry or Agency concerned fails to comply with the advice of the Commissioner of the Agency for Cultural Affairs, given in regard to the repairs, restoration or measures as provided for in paragraph 1 item (2) of the preceding Article;

(2) Where it is not deemed appropriate to have the said repairs or restoration or measures undertaken by the head of the Ministry or Agency concerned, in the case where the national treasure, or the special historic site, place of scenic beauty and/or natural monument is damaged or in decay, or where there is a fear that such property may be destroyed or damaged, fall into decay, or may be stolen.

**Article 94.** In case the Minister of Education deems it necessary for the purpose of designating a State property as national treasure, as important cultural property, as important tangible folk-cultural property, as special historic site, place of scenic beauty and/or natural monument, or as historic site, place of scenic beauty and/or natural monument, or for the purpose of clearly grasping the conditions of the State property designated as such, he/she may demand of the head of the Ministry or Agency concerned a report necessary for the investigation, or may, except for the case regarding the important tangible folk-cultural property, appoint a person or persons who are conduct the investigation and let them carry it out on the spot.

**Article 95.** In case the Commissioner of the Agency for Cultural Affairs deems it positively necessary for the purpose of preservation of the State property designated as an important cultural property, as an important tangible folk-cultural property or as a historic site, place of scenic beauty and/or natural monument, he/she may appoint an appropriate local public body or any other appropriate juridical person and charge it with the conduct of custody necessary for the preservation of such cultural property (including the care of such facilities, equipments or any other objects in the ownership or custody of the State as are needed for the preservation of the said cultural property).

2. In making appointment under the provision of the preceding paragraph, the Commissioner of the Agency for Cultural Affairs shall obtain in advance the consent of the head of the Ministry or Agency in charge of the custody of the cultural property concerned, through the Minister of Education, as well as that of the local public body or any other juridical person to be appointed as such.

3. To the appointment under the provision of paragraph 1 the provisions of Article 32-2 paragraphs 3 and 4 shall apply *mutatis mutandis*.

4. Any profit raised from the exercise of the custody under the provision of paragraph 1 shall revert to the local public body or any other juridical person concerned.

5. In regard to the custody undertaken by the local public body or any other juridical person in accordance with the provision of paragraph 1, the following provisions shall apply *mutatis mutandis* as follows: the provisions of Article 30, Article 31 paragraph 1, Article 32-4 paragraph 1, Articles 33, 34, 35 and 36, Article 47-2 paragraph 3 and Article 54 to the custody of the important cultural property or of the important tangible folk-cultural property; and those of Article 30, Article 31 paragraph 1, Articles 33 and 35, Article 72 paragraphs 1 and 2, Article 72-2 paragraphs 1 and 3, Article 76 and Article 82 to the custody of the historic site, place of scenic beauty and/or natural monument.

**Article 95-2.** To the annulment of the appointment under the provision of paragraph 1 of the preceding Article the provision of Article 32-3 shall apply *mutatis mutandis*.

**Article 95-3.** In case the Commissioner of the Agency for Cultural Affairs deems it positively necessary for the purpose of protection of important cultural property, important tangible folk-cultural property, or historic site, place of scenic beauty and/or natural monument, he/she may make the local public body or any other juridical person appointed to conduct custody under the provision of Article 95 paragraph 1 undertake the repair or restoration of the cultural property concerned.

2. In case the local public body or any other juridical person is made to undertake the repair or restoration under the provision of the preceding paragraph, the provision of Article 95 paragraph 2 shall apply *mutatis mutandis*.
3. In regard to the execution of repair or restoration by the local public body or any other juridical person under the provision of paragraph 1, the following provisions shall apply *mutatis mutandis* as specified below: the provisions of Article 32-4 paragraph 1 and Article 35 to the repair or restoration of the important cultural property or of the important tangible folk-cultural property, and those of Article 35, Article 72-2 paragraph 1 and Article 73 to that of the historic site, place of scenic beauty and/or natural monument.

**Article 95-4.** The local public body appointed under the provision of Article 95 paragraph 1 may use without compensation the land or the building which is covered by the designation of the important cultural property, important tangible folk-cultural property or historic site, place of scenic beauty and/or natural monument, belonging to the State ownership, within the limits of its custodial necessity.

2. The provisions of Article 22 paragraphs 2 and 3 of the State property Law shall apply *mutatis mutandis* to the case where the land or building may be used under the provision of the preceding paragraph.

**Article 96.** When the Commissioner of the Agency for Cultural Affairs intends to execute himself/herself an excavation under the provision of Article 58 paragraph 1, if the land where the said excavation is to take place is owned by the State or occupied by any organ of the State, he/she shall consult in advance, through the Minister of Education, the head of the Ministry or Agency concerned with respect to the purpose, method and date of commencement of the excavation, and any other matters deemed necessary; however, if the head of the Ministry or Agency concerned is the Minister of Education, his/her approval shall be secured.

**Article 97.** The Commissioner of the Agency for Cultural Affairs shall keep in custody the cultural property which has reverted to the National Treasury under the provisions of Article 63; however, the objects which had better be placed in the custody of any other organ for the purpose of its preservation or in view of its utility shall be transferred to the custody of such more appropriate organ.

(Special Provisions Regarding the State in Connection with Registered Tangible Cultural Properties)

**Article 97-2.** When registered tangible cultural properties belonging to the State which are buildings have been registered in accordance with the provision of Article 56-2 paragraph 1, the notice or the certificate of registration to be issued to the owner under the provisions of Article 56-2-2 paragraph 1 or 3 shall be issued to the head of the Ministry or Agency in charge of the custody of the registered tangible cultural property concerned.

2. When the registration of a registered tangible cultural property belonging to the State has been annulled under the provisions of Article 56-2-3 paragraph 1 or 2, the notification to be given to its owner under paragraph 3 of the same Article shall be made to the head of the Ministry or Agency in charge of the custody of the registered tangible cultural property concerned. In this case, the head of the Ministry or Agency concerned shall send back the certificate of designation to the Minister of Education without delay.

**Article 97-3.** The head of the Ministry or Agency in concerned shall give notice to the Commissioner of the Agency of Cultural Affairs through the Minister of Education in the following cases:

- (1) Where a registered tangible cultural property has been acquired;
- (2) Where there has been a transfer of jurisdiction or of administrative control with respect to any registered tangible cultural property;
- (3) Where a registered tangible cultural property under the jurisdiction of the Ministry or Agency has been entirely or partially destroyed or damaged;

- (4) Where the existing status of a registered tangible cultural property is to be altered;
2. When any State organ other than the heads of the Ministries and Agencies intends to alter the existing state of a registered tangible cultural property, it must notify the Commissioner of the Agency for Cultural Affairs.
3. The proviso of Article 32 paragraph 1 shall apply *mutatis mutandis* to notifications under paragraph 1 items (1) and (2), and likewise the proviso of 56-2-5 to notifications under paragraph 1 item (3), and the proviso of 56-2-7 paragraph 1 to notifications under paragraph 1 item (4) and the preceding paragraph.
4. The proviso of Article 56-2-7 paragraph 1 and the provisions of paragraph 2 shall apply *mutatis mutandis* to alterations to the existing state under paragraph 1 item (4) and paragraph 2.
5. When deemed necessary for the protection of a registered tangible cultural property, the Commissioner of the Agency for Cultural Affairs can, through the Minister of Education, state his opinion to the head of the Ministry or Agency concerned, or to State organs other than the heads of the Ministries and Agencies, concerning alterations to the existing state under paragraph 1 item (4) and paragraph 2.

**Article 97-4.** When it is deemed necessary to confirm the status of a registered tangible cultural property belonging to the State, the Minister of Education can demand of the head of the Ministry or Agency concerned a report necessary for that investigation.

**Article 97-5.** To registered tangible cultural properties belonging to the State, the provisions of Article 56-2-4 paragraphs 3 to 5 inclusive, of Article 56-2-6 paragraph 2, and of Article 56-2-9 paragraph 3 shall not apply.

### Section 3. Local Public Bodies and Boards of Education

(Functions of Local Public Body)

**Article 98.** Local public bodies may issue subsidies in regard to the expenses required for the preservation and utilization of cultural properties, including their custody, repair, restoration and public viewing.

2. Any local public body may, in accordance with its own regulations, designate important items of cultural properties which are located within its own administrative limits and that which are not designated by the State as important cultural properties, the important intangible cultural properties, important tangible folk-cultural properties, important intangible folk-cultural properties or historic sites, places of scenic beauty and/or natural monuments, and take necessary measures for their preservation and utilization.
3. In case a local public body has enacted, revised or abolished its own regulations mentioned in the preceding paragraph, or in case it has designated cultural properties or annulled such designation, its Board of Education shall report the fact to the Commissioner of the Agency for Cultural Affairs in accordance with the Ministry of Education Ordinance.

**Article 98-2.** When local public bodies deem it necessary to investigate the buried cultural property, they may, excepting those which the Commissioner of the Agency for Cultural Affairs undertakes to excavate in accordance with the provision of Article 58 paragraph 1, undertake to excavate the land considered to contain buried cultural properties.

2. In cases where a local public body intends to undertake excavation in accordance with the provision of the preceding paragraph, if the land where it is to be undertaken belongs to the State ownership or occupied by a State organ, responsible Board of Education shall consult in advance the head of the Ministry or Agency concerned or any other State organ with respect to the purpose, method and date of commencement of the excavation, and any other matters deemed necessary.
3. The local public body may ask the undertaker for his/her cooperation in regard to the excavation carried out in accordance with paragraph 1.
4. The Commissioner of the Agency for Cultural Affairs may give the local public body necessary guidance and advice concerning the excavation carried out under paragraph 1.

5. The State may grant the local public body a subsidy to cover part of the expenses required for the excavation carried out under paragraph 1.

Article 98-3. In case the Board of Education of a To, Do, Fu or Ken (Prefecture) or of a designated city, etc. has discovered a cultural property through an excavation carried out in accordance with the provision of paragraph 1 of the preceding Article, the provisions of Article 59 and Article 62 shall apply *mutatis mutandis*. In this case, "Article 59 paragraph 1 or paragraph 2 of the preceding Article" mentioned in Article 62 shall read "Article 59 paragraph 1 which applies *mutatis mutandis* under Article 98-3 paragraph 1."

2. As for the application of the provision of Article 63 under the preceding paragraph, "Article 59 paragraph 1 or Article 61 paragraph 2" mentioned in Article 63 paragraph 1 shall be taken as "Article 59 paragraph 1 which applies *mutatis mutandis* under Article 98-3 paragraph 1."

(Consideration with Respect to Local Bond)

Article 98-4. With respect to local bonds to be issued by local public bodies as a means of raising necessary funds for carrying out undertakings for the sake of preservation and utilization of cultural properties, appropriate consideration shall be given, within the limits of laws and regulations, and as far as the financial situation and the financial conditions of the said local public bodies permit.

(Delegation of Competence)

Article 99. When deemed necessary, the Commissioner of the Agency for Cultural Affairs may delegate to the Boards of Education of To, Do, Fu or Ken (Prefectures), or of designated cities, etc., part of his/her competence as listed below:

- (1) Direction and supervision under the provision of Article 35 paragraph 3 (including the cases where this paragraph applies *mutatis mutandis* under Article 36 paragraph 3 [including the cases where this paragraph applies *mutatis mutandis* under Article 56-14, Article 76 paragraph 2 (including the cases where the latter paragraph applies *mutatis mutandis* under Article 95 paragraph 5) and Article 95 paragraph 5], Article 37 paragraph 4 [including the case where this paragraph applies *mutatis mutandis* under Article 56-14 and Article 77 paragraph 3], Article 46-2 paragraph 2, Article 56-6 paragraph 2, Article 56-9 paragraph 2 [including the cases where this paragraph applies *mutatis mutandis* under Article 56-21], Article 56-14, Article 56-18 paragraph 2, Article 73-2, Article 75, Article 81-2 paragraph 2, Article 95 paragraph 5 and Article 95-3 paragraph 3);

- (2) Permission for the alteration of the existing state or for the acts affecting preservation, cancellation of such permission, and order for suspension of such alteration or acts, under the provision of Article 43 or Article 80 (excluding permission for gross alteration of the existing state or for acts seriously affecting preservation, and cancellation of such permission);

- (3) Order for suspension of public viewing under the provision of Article 51 paragraph 5, Article 51-2 (including the cases where this Article applies *mutatis mutandis* under Article 56-16), Article 56-15 paragraph 2 and Article 56-16;

- (4) Permission for public viewing, cancellation thereof and order for suspension of such act, under the provisions of Article 53 paragraphs 1, 3 and 4.

- (5) Investigation or execution of measures necessary there of under the provisions of Article 54 (including the cases where the same Article applies *mutatis mutandis* under Article 56-17 and Article 95 paragraph 5), Article 55, Article 82 (including the cases where this Article applies *mutatis mutandis* under Article 95 paragraph 5), or Article 83;

- (6) Order for the suspension of the act of excavation under the provision of Article 57 paragraph 2.

2. In case the Boards of Education of To, Do, Fu or Ken (Prefectures), or of designated cities, etc., by virtue of the competence delegated to them under the provision of the preceding paragraph, cancel the permission under item (2) or (4) of the same paragraph, or in case they execute investigation by entry into land or take measures necessary therefor under item (5) of the same paragraph, the provisions of Article 85 shall apply *mutatis mutandis*, respectively.

3. With respect to such acts as provided for in the preceding paragraph, out of those of the execution of the public authority including the disposition which the Boards of Education of To, Do, Fu or Ken (Prefectures), or of designated cities, etc., have made by virtue of the competence delegated under the provision of paragraph 1, no one can address an appeal of dissatisfaction under the Administrative Appeal Law.
4. The provisions of Articles 85-3 to 85-7 inclusive shall apply *mutatis mutandis* to the procedure for appeal to the Commissioner of the Agency for Cultural Affairs for examination on the acts of execution of the public authority including the dispositions made by the Boards of Education of To, Do, Fu or Ken (Prefectures), or of designated cities, etc., and the provision of Article 85-8 to the appeal for annulment of the dispositions provided for in Article 85-3 paragraph 1 item (1) which were made by the Boards of Education of To, Do, Fu or Ken (Prefectures), or of designated cities, etc.

(Delegation of Custody of Important Cultural Properties on Display)

**Article 100.** When deemed necessary, the Commissioner of the Agency for Cultural Affairs may delegate to the Boards of Education of To, Do, Fu or Ken (Prefectures), or of designated cities, etc., the duties relating to the custody of the important cultural properties or important tangible folk-cultural properties displayed under the provisions of Article 48 (including the cases where this Article applies *mutatis mutandis* under Article 56-16).

2. The Boards of Education of To, Do, Fu or Ken (Prefectures), or of designated cities, etc., to which the duties referred to in the preceding paragraph have been delegated, shall appoint from among their personnel persons who are to undertake the custody of the important cultural properties or important tangible folk-cultural properties in question.

(Delegation of Judgement of Objects Presented as Buried Objects)

**Article 100-2.** When deemed necessary, the Commissioner of the Agency for Cultural Affairs shall delegate to the Boards of Education of To, Do, Fu or Ken (Prefectures), or of designated cities, etc., the duties of judgement provided for in Article 61 paragraph 1, of notification and sending back the object, provided for in paragraph 2 of the same Article and of deliver provided for in Article 62 (exclusively the delivery of the cultural property prescribed in Article 62 paragraph 2).

2. When duties are delegated under the provision of the preceding paragraph, the presentation of the object by the chief of the station under Article 60 shall be made to the prefectural or municipal Board of Education to which such duties are delegated.

(Trust of Execution of Repairs, etc.)

**Article 101.** With respect to repairs of the national treasure or preventive measures against its destruction, damage or theft provided for in Article 38 paragraph 1 or in Article 93, excavation of buried cultural property provided for in Article 58 paragraph 1, restoration of the special historic site, place of scenic beauty and/or natural monument or preventive measures against its destruction, damage, decay or theft provided for in Article 78 paragraph 1 or in Article 93, the Commissioner of the Agency for Cultural Affairs may, when he/she deems it necessary, entrust the Boards of Education of To, Do, Fu or Ken (Prefectures) with the execution of the whole or a part of such affairs.

2. In case the Boards of Education of To, Do, Fu or Ken (Prefectures) act by virtue of the trust provided for in the preceding paragraph, the following provisions shall apply *mutatis mutandis* respectively: the provisions of Article 39, when whole or part of the repairs or measures mentioned in Article 38 paragraph 1 is to be executed; the provisions of Article 39 applying *mutatis mutandis* under Article 58 paragraph 3, when whole or part of the excavation mentioned in Article 58 paragraph 1 is to be executed; the provisions of Article 39 applying *mutatis mutandis* under Article 78 paragraph 2, when whole or part of the restoration or measures mentioned in Article 78 paragraph 1 is to be executed.



(Acceptance of Trust of Custody, etc. of Important Cultural Property or Technical Guidance thereon)

**Article 102.** Upon request of the owner (the custodial body, if such has been appointed) or of the custodian, the board of Education of To, Do, Fu or Ken (Prefecture) may, with previous approval by the Commissioner of the Agency for Cultural Affairs, accept the trust of custody (excluding the cases where a custodial body has been appointed), repair or restoration of the important cultural property, of important tangible folk-cultural property or of historic site, place of scenic beauty and/or natural monument, or give technical guidance thereon.

2. The provisions of Article 39 paragraphs 1 and 2 shall apply *mutatis mutandis*, when the Board of Education of To, Do, Fu or Ken (Prefecture) accepts the trust of custody, repair or restoration under the preceding paragraph.

(Channel for Presentation of Papers, etc.)

**Article 103.** Reports and other papers, as well as objects, to be submitted to the Minister of Education or to the Commissioner of the Agency for Cultural Affairs under the provisions of this Law with regard to the cultural property, shall go through the Board of Education of To, Do, Fu or Ken (Prefecture) concerned.

2. The Board of Education of To, Do, Fu or Ken (Prefecture), upon receiving the papers and objects mentioned in the preceding paragraph, shall forward them to the Minister of Education or to the Commissioner of the Agency for Cultural Affairs together with the statement of its own opinions thereon.
3. Notification of order, advice, instruction and any other kinds of disposition to be issued by the Minister of Education or the Commissioner of the Agency for Cultural Affairs under the provisions of this Law with regard to cultural property, shall go through the Board of Education of To, Do, Fu or Ken (Prefecture) concerned; this shall not apply, however, in cases of extreme urgency.
4. The act of reporting, proposal, or returning of the certificate of designation to the Minister of Education or to the Commissioner of the Agency for Cultural Affairs as provided for by this Law shall be deemed as complete at the time when such report or other document or the certificate of designation has reached the Board of Education of To, Do, Fu or Ken (Prefecture) which it is to go through in accordance with the provision of paragraph 1.

(Direction, Supervision and Payment of Expenses)

**Article 104.** The Commissioner of the Agency for Cultural Affairs may direct and supervise the Boards of Education of To, Do, Fu or Ken (Prefectures), or of designated cities, etc., with respect to the duties which the said Commissioner makes such Boards perform.

2. The expenses which the Boards of Education of To, Do, Fu or Ken (Prefectures), or of designated cities, etc., require for carrying out the duties mentioned in the provisions of Articles 99 to 101 inclusive shall be borne by the National Treasury.

(Presentation of Opinions to the Minister of Education or the Commissioner of the Agency for Cultural Affairs)

**Article 104-2.** The Boards of Education of To, Do, Fu or Ken (Prefectures), or of municipalities (including municipal federations and special districts; hereinafter the same in this Section), may present their opinions to the Minister of Education or to the Commissioner of the Agency for Cultural Affairs concerning the preservation and utilization of the cultural properties which are located within their administrative districts.

(Regional Cultural Properties Protection Council)

**Article 105.** Any prefectural or municipal Board of Education may, in accordance with its own regulations, have a Regional Cultural Properties Protection Council.

2. The Regional Cultural Properties Council shall, upon inquiry of the prefectural or municipal Board of Education concerned, investigate and deliberate important matters concerning the preservation and utilization of cultural properties as well as make proposals to the said Board of Education with respect to such matters.

3. Particulars concerning the organization and management of the Regional Cultural Properties Protection Council shall be determined by the regulations of the prefecture or municipality concerned.

(Specialist-Members for Cultural Property Protection)

**Article 105-2.** The Board of Education of To, Do, Fu or Ken (Prefecture) may have specialist-members for cultural property protection.

2. The specialist-members for cultural property protection shall from time to time make inspection tours of cultural properties, give guidance and advice to their owners and other related persons in regard to the protection of cultural properties and also undertake educational activities for community people on the spirit of the protection of cultural properties.
3. The specialist-members for cultural property protection shall serve on a part-time basis.

## CHAPTER VII Penal Provisions

(Criminal Penalties)

**Article 106.** Any person who has, in contravention of the provision of Article 44, exported any important cultural property without obtaining the permission of the Commissioner of the Agency for Cultural Affairs shall be liable to imprisonment, with or without hard labor, for a term not exceeding five (5) years or to a fine not exceeding one million (1,000,000) yen.

**Article 107.** Any person who has damaged, discarded or secreted any important cultural property shall be liable to imprisonment, with or without hard labor, for a term not exceeding five (5) years or to a fine not exceeding three hundred thousand (300,000) yen.

2. If the person mentioned in the preceding paragraph happens to be the owner of the important cultural property in question, he/she shall be liable to imprisonment, with or without hard labor, for a term not exceeding two (2) years or to a fine of minor fine not exceeding two hundred thousand (200,000) yen.

**Article 107-2.** Any person who has altered the existing state of a historic site, place of scenic beauty and/or natural monument, or by practicing any act affecting its preservation destroyed it, damaged it or brought it to decay, shall be liable to imprisonment, with or without hard labor, for a term not exceeding five (5) years or to fine not exceeding three hundred thousand (300,000) yen.

2. If the person mentioned in the preceding paragraph happens to be the owner of the historic site, place of scenic beauty and/or natural monument in question, he/she shall be liable to imprisonment, with or without hard labor, for a term not exceeding two (2) years or to a fine or minor fine not exceeding two hundred thousand (200,000) yen.

**Article 107-3.** The person who comes under any of the following items shall be liable to a fine not exceeding two hundred thousand (200,000) yen.

- (1) Any person who has, in violation of the provisions of Article 43 or Article 80, altered the existing state of or done an act affecting the preservation of any important cultural property or any historic site, place of scenic beauty and/or natural monument with obtaining the permission of the Commissioner of the Agency for Cultural Affairs or the Board of Education of To, Do, Fu or Ken (Prefecture) or designated city, etc., to which the Commissioner of the Agency for Cultural Affairs had delegated his competence, or without complying with the conditions of such permission, or failed to obey the order of the said Commissioner or Board of Education issued to the violator to suspend the act of altering the existing state or affecting preservation;
- (2) Any person who has, in contravention of the provision of Article 57-5 paragraph 2, failed to obey the order of suspension or prohibition of the act which may lead to the alteration of the existing state issued by the Commissioner of the Agency for Cultural Affairs.

**Article 107-4.** The person who comes under any of the following items shall be liable to a fine not exceeding ten thousand (10,000) yen;

(1) Any person who has refused or interfered with the execution of repair or of any measure for the prevention of destruction, damage or theft of a national treasure, in contravention of the provision of Article 32-2 paragraph 5 applying *mutatis mutandis* under Article 39 paragraph 3 (including the cases where this paragraph applies *mutatis mutandis* under Article 101 paragraph 2);

(2) Any person who has refused or interfered with the execution of excavation, in contravention of the provision of Article 32-2 paragraph 5 applying *mutatis mutandis* under Article 39 paragraph 3 which applies *mutatis mutandis* under Article 58 paragraph 3 (including the cases where this paragraph applies *mutatis mutandis* under Article 101 paragraph 2);

(3) Any person who has refused or interfered with the execution of restoration or of any measure for the prevention of destruction, damage decay or theft of the special historic site, place of scenic beauty and/or natural monument, in contravention of the provision of Article 32-2 paragraph 5 applying *mutatis mutandis* under Article 39 paragraph 3 which applies *mutatis mutandis* under Article 78 paragraph 2 (including the cases where this paragraph applies *mutatis mutandis* under Article 101 paragraph 2);

**Article 107-5.** In case the representative of a juridical person, or the proxy, a servant or any other employee of a juridical person or of a natural person has committed any of the offenses mentioned in the preceding five Articles, in regard to the performance of duties or custody of property for which such juridical or natural person concerned by the same particular Article.

#### (Administrative Penalties)

**Article 108.** If a person appointed as responsible for the execution of custody, repairs or restoration of any important cultural property, important tangible folk-cultural property or historic site, place of scenic beauty and/or natural monument, in accordance with the provision of Article 39 paragraph 1 (including the cases where this paragraph applies *mutatis mutandis* under Article 47 paragraph 3 (including the cases where the latter applies *mutatis mutandis* under Article 56-14, Article 78 paragraph 2, Article 101 paragraph 2 or Article 102 paragraph 2), Article 49 (including the cases where this paragraph applies *mutatis mutandis* under Article 56-16), or Article 100 paragraph 2, has destroyed, damaged or brought to decay the same property or has it stolen, by negligence or serious fault in duty, he/she shall be liable to a non-criminal fine not exceeding three hundred thousand (300,000) yen.

**Article 109.** The person who comes under any of the following items shall be liable to a non-criminal fine not exceeding three hundred thousand (300,000) yen:

(1) Any person who has failed to obey without justifiable reasons such order of the Commissioner of the Agency for Cultural Affairs as may be issued under Article 36 paragraph 1 (including the cases where this paragraph applies *mutatis mutandis* under Article 56-14 and Article 95 paragraph 5) or Article 37 paragraph 1 pertaining to the custody of an important cultural property or an important tangible folk-cultural property, or to the repair of a national treasure;

(2) Any person who has failed to obey without justifiable reasons such order of the Commissioner of the Agency for Cultural Affairs as may be issued under the provision of Article 76 paragraph 1 (including the cases where this paragraph applies *mutatis mutandis* under Article 95 paragraph 5) or Article 77 paragraph 1 pertaining to the custody of a historic site, place of scenic beauty and/or natural monument, or to the restoration of a special historic site, place of scenic beauty and/or natural monument.

**Article 110.** Any person who comes under any of the following items shall be liable to a non-criminal fine not exceeding one hundred thousand (100,000) yen:

(1) Any person who has, without justifiable reasons, disobeyed the restriction, prohibition or the order for provision of facilities issued under Article 45 paragraph 1;

- (2) Any person who, in contravention of the provisions of Article 46 (including the cases where this Article applies *mutatis mutandis* under Article 56-14), has failed to make the Commissioner of the Agency for Cultural Affairs an offer of sale to the State or after making the said offer to him/her has transferred the important cultural property or important tangible folk-cultural property in question to any other party than the State within the period prescribed in paragraph 3 of the same Article (including the cases where this paragraph applies *mutatis mutandis* under Article 56-14), or has given false statements in making the offer of sales under paragraph 1 of the same Article (including the cases where this paragraph applies *mutatis mutandis* under Article 56-14) or in making an application for approval referred to in the proviso to the same paragraph (including the cases where this paragraph applies *mutatis mutandis* under Article 56-14);
- (3) Any person who has failed to display or open the property concerned to the public, in contravention of the provision of Article 48 paragraph 4 (including the cases where this paragraph applies *mutatis mutandis* under Article 51 paragraph 3 [including the cases where the latter paragraph applies *mutatis mutandis* under Article 56-16], or who has, in violation of the provision of Article 51 paragraph 5, Article 51-2 [including the case where this Article applies *mutatis mutandis* under Article 56-16], Article 56-15 paragraph 2 and Article 56-16), failed to obey the order for suspension or discontinuance of such public viewing, which was issued by the Commissioner of the Agency for Cultural Affairs or by the Board of Education of To, Do, Fu or Ken (Prefecture) or designated city, etc. concerned to which the said Commissioner had delegated his/her competence;
- (4) Any person who has in violation of the provisions of Article 53 paragraphs 1, 3 or 4, opened any important cultural property to the public without obtaining the permission of the Commissioner of the Agency for Cultural Affairs or of the Board of Education of To, Do, Fu or Ken (Prefecture) or designated city, etc. to which the said Commissioner has delegated his competence, or without complying with the conditions of such permission, or failed to obey the order of the said Commissioner or Board of Education for the suspension of such public viewing;
- (5) Any person who has, in violation of the provisions of Article 54 (including the cases where this Article applies *mutatis mutandis* under Article 56-17 and Article 95 paragraph 5), Article 55, Article 56-2-10, Article 82 (including the cases where the latter Article applies *mutatis mutandis* under Article 95 paragraph 5), or Article 83, failed to submit a report or submitted a false report, or has refused, interfered with or evaded the responsible officials' on-the-spot investigation by entry into land or the execution of measure necessary for such investigation;
- (6) Any person who has, in violation of the provision of Article 57 paragraph 2, failed to obey the prohibition or the order for suspension or discontinuance of the act of excavation issued by the Commissioner of the Agency for Cultural Affairs or the Board of Education of To, Do, Fu or Ken (Prefecture) or designated city, etc. to which the said Commissioner has delegated his competence;
- (7) Any person who has, without justifiable reasons, disobeyed the restriction, prohibition or order for provision of facilities issued under the provision of Article 81 paragraph 1.

**Article 111.** The person who comes under any of the following items shall be liable to a non-criminal fine not exceeding fifty thousand (50,000) yen:

- (1) Any person who has failed to return to the Minister of Education the certificate of designation of an important cultural property or of an important tangible folk-cultural property, or to hand it over to the new owner of the property concerned in violation of the provision of Article 28 paragraph 5, Article 29 paragraph 4 (including the cases where this paragraph applies *mutatis mutandis* under Article 56-11 paragraph 2), Article 56 paragraph 2 (including the cases where this paragraph applied *mutatis mutandis* under Article 56-17), Article 56-2-3 paragraph 5 or Article 56-2-11;
- (2) Any person who has failed to report or who has submitted a false report in violation of the provision of Article 31 paragraph 3 (including the cases where this paragraph applies *mutatis mutandis* under Article 56-2-4 paragraph 4, Article 56-12 and Article 74 paragraph 2), Article 32 (including the cases where this Article applies *mutatis mutandis* under Article 56-2-4 paragraph 4, Article 56-12 and Article 75), Article 33 (including the cases where this Article applies *mutatis mutandis* under Article 56-12, Article 73-2, Article 75

and Article 95 paragraph 5), Article 34 (including the cases where this paragraph applies *mutatis mutandis* under Article 56-12 and Article 95 paragraph 5), Article 43-2 paragraph 1, Article 56-2-5, Article 56-2-7 paragraph 1, Article 56-5, Article 56-13 paragraph 1, the body text of Article 56-15 Paragraph 1, Article 57 paragraph 1, Article 57-5 paragraph 1, Article 72 paragraph 2 (including the cases where this paragraph applies *mutatis mutandis* under Article 75 and Article 95 paragraph 5), or Article 80-3 paragraph 1;

(3) Any person who has refused, interfered with, or evaded the execution of custody, repair or restoration of or measure necessary for such action, in violation of the provision of Article 32-2 paragraph 5 (including the cases where this paragraph applies *mutatis mutandis* under Article 34-3 paragraph 2 [including the cases where the latter applies *mutatis mutandis* under Article 56-14], Article 56-2-4 paragraph 4, Article 56-2-6 paragraph 2, and under Article 56-12) or Article 72 paragraph 4.

Article 112. Deleted.

### Supplementary Provisions

(Date of Enforcement)

Article 113. The date of the enforcement of this Law shall be provided for by Cabinet Order within a period not exceeding three (3) months from the day of its promulgation. (The same Law came into force from the 29th of August, 1950, by the Cabinet Order No. 276 of August, 1950).

(Abolition of Relevant Laws and Orders)

Article 114. The following Laws, Imperial Ordinances and Cabinet Orders are hereby abolished:

- National Treasures Preservation Law (Law No. 17 of 1929);
- Law concerning the Preservation of Important Objects of Art, etc. (Law No. 43 of 1933);
- Law for the Preservation of Historic Sites, Places of Scenic Beauty and Natural Monuments (Law No. 44 of 1919);
- Ordinance for the Enforcement of the National Treasures Preservation Law (Imperial Ordinance No. 210 of 1929);
- Ordinance for the Enforcement of the Law for the Preservation of Historic Sites, Places of Scenic Beauty and Natural Monuments (Imperial Ordinance No. 499 of 1919);
- Regulations governing the Organization of the National Treasures Preservation Society (Imperial Ordinance No. 211 of 1929);
- Order for the Important Art Objects, etc. Research Council (Cabinet Order No. 251 of 1949);
- Order for the Research Council on Historic Sites, Places of Scenic Beauty and Natural Monuments (Cabinet Order No. 252 of 1949).

(Transitional Provisions consequential upon Abolition of Laws and Orders)

Article 115. The designation of national treasures made prior to the enforcement of this Law under the provision of Article 1 of the National Treasures Preservation Law (excluding the cases where the annulment thereof has been made pursuant to Article 11 paragraph 1 of the same Law) shall be deemed as the designation of important cultural properties under Article 27 paragraph 1 of this Law, and the permission given pursuant to Article 3 or 4 of that Law shall be deemed as the permission under Article 43 or 44 of this Law.

2. With respect to the destruction or damage of national treasures which may have occurred prior to the enforcement of this Law, the orders which were given in accordance with Article 7 paragraph 1 of the National Treasures Preservation Law prior to the enforcement of this Law, and the subsidies which were granted in accordance with the former part of Article 15 of the same Law prior to the enforcement of this Law, the provisions of Articles 7 to 10 inclusive, the latter part of Article 15, and Article 24 of that

Law shall continue to be in force. In this case, "the competent Ministers" in Article 9 paragraph 2 of that same Law shall read "the National Commission for Protection of Cultural Properties."

3. With regard to the punishment of acts committed prior to the enforcement of this Law, the provisions of the National Treasures Preservation Law, excepting Articles 6 and 23 shall continue to be in force.
4. Any person who owns, at the time of the enforcement of this Law, any national treasure designated under Article 1 of the National Treasures Preservation Law, shall report to the Commission stating particulars prescribed by the Regulations of the Commission, within three (3) months from the time of the enforcement of this Law.
5. When the report mentioned in the preceding paragraph has been filed, the Commission shall issue to the owner concerned a certificate of designation of important cultural property prescribed in Article 28 of this Law.
6. Any person who, in contravention of the provision of paragraph 4, has failed to report or has filed a false report shall be liable to a non-criminal fine not exceeding five thousand (5,000) yen.
7. The head of the Ministry of Agency having control, at the time of the enforcement of this Law, over any national treasure designated under Article 1 of the National Treasures Preservation Law shall, within three (3) months from the time of the enforcement of this Law, notify the Commission in writing, stating particulars prescribed by the Regulations of the Commission; however, this shall not apply if otherwise provided for by the Regulations of the Commission.
8. When the notification has been made according to the preceding paragraph, the Commission shall issue to the head of the Ministry or Agency concerned a certificate of designation of important cultural property prescribed in Article 28 of this Law.

**Article 116.** With respect to the objects classified under the provision of Article 2 paragraph 1 of the Law concerning the Preservation of Important Objects of Art, etc. up to the time of the enforcement of this Law, the old Law shall continue to be in force for the time being. In this case, the affairs concerning the operation of that Law shall be conducted by the Commissioner of the Agency for Cultural Affairs, and "the national treasures" occurring therein shall read "the important cultural properties under the provisions of the Law for the Protection of Cultural Properties," "the competent Minister" reading "the Commissioner of the Agency for Cultural Affairs" and "designate the same objects as national treasures in accordance with Article 1 of the National Treasures Preservation Law" reading "the preceding Article."

2. The Council for the Protection of Cultural Properties shall, in response to the consultation instituted by the Commissioner of the Agency for Cultural Affairs, undertake for the time being investigation and deliberation respecting the permission of exportation under Article 1 of the Law concerning the Preservation of Important Objects of Art, etc., and matters concerning the annulment of recognition under Article 2 of the same Law, and other important matters concerning the preservation of important objects of art, etc., and shall submit to the said Commissioner such proposals as may be deemed necessary with reference to these matters.
3. With respect to the operation of the Law concerning the Preservation of Important Object of Art, etc., the provisions of Article 103 of the present Law shall for the time being apply *mutatis mutandis*.

**Article 117.** The designation of historic sites, places of scenic beauty and/or natural monuments made prior to the enforcement of this Law, in accordance with the provision of Article 1 paragraph 1 of the Law for the Preservation of Historic Sites, Places of Scenic Beauty and Natural Monuments (excepting the cases where the designation has been annulled) shall be regarded as the designation made in accordance with the provision of Article 69 paragraph 1 of this Law, the provisional designation made in accordance with the provision of Article 1 paragraph 2 of the said old Law (excepting the cases where the designation has been annulled) shall be regarded as the provisional designation made in accordance with the provision of Article 70 paragraph 1 of this Law, and the permission given in accordance with the provision of Article 3 of the said old Law shall be regarded as the permission given in accordance with the provision of Article 80 paragraph 1 of this Law.

2. With respect to the orders issued or the dispositions made prior to the enforcement of this Law, in accordance with the provision of Article 4 paragraph 1 of the Law for the Preservation of Historic Sites, Places of Scenic Beauty and Natural Monuments, the provision of Article 4 of the said Law and of Article 4 of the Ordinance for the Enforcement of the said Law shall continue to be in force. In this case, "the Minister of Education" occurring in Article 4 of the said Ordinance shall read "the National Commission for Protection of Cultural Properties."
3. As to the punishment for acts committed prior to the enforcement of this Law, the Law for the Preservation of Historic Sites, Places of Scenic Beauty and Natural Monuments shall continue to be in force.

(Appointment of the First Members)

**Article 118.** As to the appointment of the first members of the Commission, only in the case where the Diet stands prorogued or where the House of Representatives stands dissolved, an ex post facto approval of the both Houses of the Diet at the first session convened thereafter shall suffice notwithstanding the provision of Article 9 paragraph 1.

2. The Minister of Education shall, when he/she is unable to obtain the ex post facto approval of the both Houses under the provision of the preceding paragraph, remove such members from their office.

(Convocation of the First Meeting of the Commission)

**Article 119.** The First meeting of the Commission under this Law shall be convened by the Minister of Education, notwithstanding the provision of Article 14.

(Term of Office of the First Members)

**Article 120.** The term of office of the Commission members appointed first in accordance with this Law, other than the Chairperson and a member who is to act for him/her, shall be one year for one member and two years for the other two.

2. The term of office of such members under the application of the provision of the preceding paragraph shall be decided by lot.

(Partial Amendment of the National Organization Law)

**Article 121.** The National Government Organization Law shall be partially amended as follows:  
(Omitted.)

(Partial Amendment of the Ministry of Education Establishment Law)

**Article 122.** The Ministry of Education Establishment Law shall be partially amended as follows:  
(Omitted.)

(Partial Amendment of the Law concerning the Fixed Number of Personnel of Government Organs)

**Article 123.** The law concerning the Fixed Number of Personnel of Government Organs shall be partially amended as follows:  
(Omitted.)

(Former National Museums)

**Article 124.** Unless otherwise provided for by Laws (including orders thereunder) the former National Museums and the personnel thereof (excepting the Research Institutes of Art and personnel thereof) shall be the National Museums and the personnel thereof under this Law and the Research Institutes of Art attached to the former National Museums and the personnel thereof shall be the Research Institutes and the personnel thereof under this Law, and shall retain their respective identities.

2. The Tokyo National Research Institute of Cultural Properties under this Law shall be able to use the name of "Research Institute of Art," with respect to the researches and studies equivalent to those managed by the Research Institutes of Art attached to the former National Museums.

(Partial Amendment of the Law concerning Compensation for Public Service Personnel in the Special Government Service)

Article 125. The Law concerning Compensation for Public Service Personnel in the Special Government Service shall be partially amended as follows:

(Omitted.)

(Partial Amendment of the Lost Property Law)

Article 126. The Lost Property Law shall be partially amended as follows:

(Omitted.)

(Partial Amendment of the National Property Law)

Article 127. The National Property Law shall be partially amended as follows:

(Omitted.)

(Partial Amendment of the Outdoor Advertisement Law)

Article 128. The Outdoor Advertisement Law (Law No. 189 of 1949) shall be partially amended as follows:

(Omitted.)

(Partial Amendment of the Board of Education Law)

Article 129. The Board of Education Law (Law No. 170 of 1948) shall be partially amended as follows:

(Omitted.)

(Partial Amendment of the Net Fortune Tax Law)

Article 130. The Net Fortune Tax Law (Law No. 174 of 1950) shall be partially amended as follows:

(Omitted.)

#### Supplementary Provisions

(Law No. 318, December 24, 1951)

(Extract)

1. The Law shall come into force as from the day of its promulgation. However, the revised provisions of Articles 20, 22, 23 and Article 124 paragraph 2 as well as the provision of paragraph 3 of the Supplementary Provisions shall come into force as from April 1, 1952.
2. With regard to the application of the penal provisions to the acts committed prior to the enforcement of this Law, the provisions of Article 34 of the Law for the Protection of Cultural Properties before the amendment shall continue to be in force.

#### Supplementary Provisions

(Law No. 272, July 31, 1952)

(Extract)

(Date of Enforcement)

1. This Law shall come into force as from August 1, 1952. The provision of paragraph 3 of the Supplementary Provisions, however, shall come into force as from the day of its promulgation.



(Transitional Provisions concerning Personnel of Branch Office of Tokyo National Museum)

2. Those who are the personnel of the branch office of the Tokyo National Museum at the time of the enforcement of this Law shall be the personnel of the Nara National Museum under the same conditions of service unless an official announcement of appointment is otherwise issued.

#### Supplementary Provisions

(Law No. 194, August 10, 1953)  
(Extract)

1. This Law shall come into force as from the day of its promulgation.

#### Supplementary Provisions

(Law No. 213, August 15, 1953)  
(Extract)

1. This Law shall come into force as from September 1, 1953.  
(Omitted hereinafter.)
2. The permission, approval and other dispositions or application, report and other proceedings made under the provisions of former laws and orders prior to the enforcement of this Law shall be deemed as the dispositions or proceedings made under the corresponding provisions respectively after the revision.
3. The organs or the personnel established under the provisions of the former laws and orders at the time of enforcement of this Law shall be deemed as established under the corresponding provisions respectively after the revision.

#### Supplementary Provisions

(Law No. 131, May 29, 1954)  
(Extract)

1. This Law shall come into force as from July 1, 1954.
2. The provisional designation of a historic site, place of scenic beauty and/or natural monument made prior to the enforcement of this Law shall, notwithstanding the provision of Article 71 paragraph 2 of the Law for the Protection of Cultural Properties after the revision under this Law (hereinafter referred to as "the new Law") become null and void, when the designation has been made under the provision of Article 69 paragraph 1 of the new Law or when no designation under the same provision has been made of the same property within three years of the day of enforcement of this Law.
3. Any person dissatisfied with such disposition as the permission or rejection for the alteration of the existing state, etc. made within six (6) months before the enforcement of this Law under the provision of Article 43 paragraph 1 or Article 80 paragraph 1 of the former Law for the Protection of Cultural Properties prior to the revision under this Law or with the restriction, prohibition or order issued to particular persons under the provision of Article 45 paragraph 1 or Article 81 paragraph 1 of the same former Law may place a protest before the Commission within thirty (30) days of the day of enforcement of this Law. In this case, the provisions of Article 85-2 paragraphs 2 and 3 and Articles 85-3 to 85-9 inclusive shall apply *mutatis mutandis*.
4. With regard to the application of penal provisions for the acts conducted before the enforcement of this Law the precedent shall be followed.
5. The Cabinet Order concerning the Designation, etc. of Bodies for the Conduct of Custody of the Historic Site, Place of Scenic Beauty and/or Natural Monument (Cabinet Order 289 of 1953) shall be deleted.

6. The local public body or any other body designated under Article 1 paragraph 1 of the Cabinet Order concerning the Designation, etc. of Bodies to take Custody of the Former Historic Site, Place of Scenic Beauty and/or National Monument, and the body who is a juridical person and has been recognized under the provision of paragraph 2 of the Supplementary Provisions to the same Order as a local public body or any other body designated under the provision of Article 1 paragraph 1 of the same Order shall be deemed as a local public body or any other juridical person designated under the provision of Article 71-2 paragraph 1 or Article 95 paragraph 1.
7. The body which is provided for in the preceding paragraph but is not a juridical person may, notwithstanding the provision of Article 71-2, Article 95 or Article 95-3 of the new Law, be charged during one year of the day of enforcement of this Law with the conduct of custody and restoration provided for in Article 71-2 paragraph 1, Article 95 paragraph 1 or Article 95-3 paragraph 1 of the new Law. In this case the provisions concerning a juridical person designated under the provision of Article 71-2 paragraph 1 or Article 95 paragraph 1 of the new Law shall apply *mutatis mutandis*.

**Supplementary Provisions**

(Law No. 148, June 12, 1956)  
(Extract)

1. This Law shall come into force as from the day of the enforcement (September 1, 1956) of the Law concerning Partial Revision of the Local Autonomy Law (Law No. 147 of 1956).

**Supplementary Provisions**

(Law No. 163, June 30, 1956)  
(Extract)

(Date of Enforcement)

1. This Law shall come into force as from October 1, 1956. (Omitted hereinafter.)

**Supplementary Provisions**

(Law No. 86, April 25, 1958)  
(Extract)

1. This Law shall come into force (Omitted.) as from the day of its promulgation.

**Supplementary Provisions**

(Law No. 148, April 20, 1959)  
(Extract)

(Date of Enforcement)

1. This Law shall come into force as from the day of the enforcement (January 1, 1960) of the National Tax Collection Law (Law No. 147 of 1959).

### Supplementary Provisions

(Law No. 111, June 2, 1961)  
(Extract)

(Date of Enforcement)

1. This Law shall come into force as from the day of its promulgation and applicable as from April 1, 1951.

### Supplementary Provisions

(Law No. 140, May 16, 1962)  
(Extract)

1. This Law shall come into force as from October 1, 1962.
2. The provisions revised by this Law shall apply to such matters as taken place prior to the enforcement of this Law, unless otherwise provided for by these Supplementary Provisions; however, the effect taken under the provisions provided for prior to the revision by this Law shall be retained.
3. With regard to the lawsuits pending at the time of the enforcement of this Law the precedent shall be followed, notwithstanding the provisions revised by this Law which prescribes that the lawsuits in question shall not be instituted.
4. With regard to the jurisdiction over the lawsuits pending at the time of the enforcement of this Law, the precedent shall be followed notwithstanding the provisions revised by this Law which makes the jurisdiction concerned an exclusive jurisdiction.
5. With regard to the period of institution of a lawsuit for the disposition or the decision for with the period of a lawsuit is in progress at the time of the enforcement of this Law according to the provisions provided for prior to the revision under this Law, the precedent shall be followed; however, this shall apply exclusively to the case where the period of institution of a lawsuit under the provisions revised by this Law is shorter than that of institution of a lawsuit under the provisions provided for prior to the revision by this Law.
6. The period of institution of the lawsuit of parties for the disposition or the decision made prior to the enforcement of this Law, which is to be decided according to the revision by this Law, shall be counted as from the day of the enforcement of this Law.
7. With regard to the lawsuit for revocation of the disposition or the decision pending at the time of the enforcement of this law, the precedent shall be followed notwithstanding the provision revised by this Law that one of the parties related to the law concerned shall be a defendant; however the court concerned may permit by its decision to change the lawsuit in question into the lawsuit of parties.
8. In case of the proviso to the preceding paragraph, the provisions of the latter part of Article 18 and Article 21 paragraphs 2 to 5 inclusive of the Administrative Litigation Law shall apply *mutatis mutandis*.

### Supplementary Provisions

(Law No. 161, September 15, 1962)  
(Extract)

1. This Law shall come into force as from October 1, 1962.
2. The provisions revised by this Law shall apply, unless otherwise provided for by these Supplementary Provisions, to the dispositions made by the administrative agency prior to the enforcement of this Law, the forbearance of the administrative agency as to the application made prior to the enforcement of this Law and other matters taken place prior to the enforcement of this Law; however the effect taken under the provisions provided for prior to the revision by this Law shall be retained.

3. With regard to the petitions, the requests for examination, the protests, or other appeals of dissatisfaction (hereinafter referred to as "the petitions, etc.") filed prior to the enforcement of this Law, the precedent shall be followed even after the enforcement of this Law. With regard to the petitions, etc. of those who are dissatisfied with the judgements, decisions or other dispositions (hereinafter referred to as "the judgements, etc.") on the petitions, etc. formed prior to the enforcement of this Law, or the judgements, etc. which are to be given after the enforcement of this Law on the petitions, etc. filed before the enforcement of this Law, the same shall apply.
4. The petitions, etc. provided for in the preceding paragraph, relating to the dispositions against which appeals of dissatisfaction may be instituted according to the Administrative Appeal Law after the enforcement of this Law, shall concerning the application of laws other than that Law, be deemed as the appeals of dissatisfaction instituted under the Administrative Appeal Law.
5. With regard to the judgement, etc. on the requests for examination, the protests or other appeals of dissatisfaction to be formed after the enforcement of this Law according to the provision of paragraph 3, no appeal of dissatisfaction can be instituted under the Administrative Appeal Law.
6. With regard to the dispositions which were made by the administrative agency prior to the enforcement of this Law and against which the petitions, etc. could be formed according to the provisions provided for prior to the revision of this Law and of which the period for institution was not decided, the period during which appeals of dissatisfaction can be instituted shall be counted as from the day of the enforcement of this Law.
8. With regard to the application of the penal provisions to such actions as conducted prior to the enforcement of this Law, the precedent shall be followed.
9. Other than those provided for in the preceding eight paragraph, transitional measures necessary for the enforcement of this Law shall be decided by the Cabinet Order.
10. In case where this Law and the Law for Adjustment of Laws concerned in Compliance with the Enforcement of the Law concerning Legal Procedure for Administrative Cases (Law No. 140 of 1952) have revised provisions relating to one and the same Law, the last one shall be revised first by this Law and then revised by the Law for Adjustment of Laws concerned in Compliance with the Enforcement of the Law concerning Legal Procedure for Administrative Cases.

### Supplementary Provisions

(Law No. 36, March 31, 1965)  
(Extract)

(Date of Enforcement)

**Article 1.** This Law shall come into force as from April 1, 1965. (Hereinafter omitted.)

(Principle in Transitional Measures in Compliance with Partial Amendment of Other Laws and Orders)

**Article 5.** The provisions of the laws and orders after the revision under the provisions of Chapter II shall, unless otherwise provided for, apply to the income tax after that for 1965 or to the corporation tax for a business year of juridical persons provided for in the provisions of such laws and orders which terminates after the day of the enforcement, and with regard to the income tax before that for 1964 or the corporation tax for a business year of the said juridical persons which terminated before the day of the enforcement, the precedent shall be followed.

(Commitment to Cabinet Order)

**Article 15.** Other than those provided for in the Article 1 to the preceding Article inclusive of the Supplementary Provisions, transitional measures necessary for the enforcement of this Law shall be decided by the Cabinet Order.

### Supplementary Provisions

(Law No. 99, June 15, 1968)

(Extract)

(Date of Enforcement)

1. This Law shall come into force as from the day of its promulgation; however the provisions of Chapter XIII shall come into force as from August 1, 1968.

(Transitional Provisions)

2. Those who are the personnel of the Cultural Affairs Bureau of the Ministry of Education, the Secretariat of the National Commission for Protection of Cultural Properties, the Institutions under the jurisdiction of the Ministry of Education (excluding those which shall become corresponding organs under the jurisdiction of the Agency for Cultural Affairs) or the auxiliary organs to the National Commission for Protection of Cultural Properties (excluding the Council of Experts on Cultural Properties) shall be the corresponding personnel of the Agency for Cultural Affairs with equivalent conditions of service, unless otherwise orders be issued.
3. The permission, approval, designation and other dispositions or the notification and other proceedings which have been made or issued at the time of enforcement of this Law by the National Commission for Protection of Cultural Properties or by the Minister of Education in accordance with the provisions of the former Laws prior to the revision by this Law, such as the Law for the Protection of Cultural Properties, the Copyright Law, the Law concerning Intermediary Services with regard to the Copyright, the Law concerning Special Provisions of the Copyright Law in Consequence of the Enforcement of the Universal Copyright Convention, the Law regulating Possession of Swords and Firearms, or the National Theater Law shall be regarded as the dispositions and proceedings made or issued by the Minister of Education or the Commissioner of the Agency for Cultural Affairs in accordance with the corresponding provisions of the Laws revised by this Law.
4. The applications, report or other proceedings which have filed at the time of the enforcement of this Law by the National Commission for Protection of Cultural Properties or the Minister of Education in accordance with the provisions of the former Laws prior to the revision by this Law, such as the Law for the Protection of Cultural Properties, the Copyright Law, the Law concerning Intermediary Services with regard to the Copyright, the Law concerning Special Provisions of the Copyright Law in Consequence of the Enforcement of the Universal Copyright Convention, the Law regulating Possession of Swords and Firearms, or the National Theater Law shall be regarded as the proceedings taken by the Minister of Education or the Commissioner of the Agency for Cultural Affairs in accordance with the corresponding provisions of the Laws revised by this Law.
5. The Regulations of the National Commission for Protection of Cultural Properties which are in force at the time of the enforcement of this Law shall have the force as the Ministry of Education Ordinance.

### Supplementary Provisions

(Law No. 88, May 31, 1971)

(Extract)

(Date of Enforcement)

Article 1. This Law shall come into force as from July 1, 1971.

(Omitted hereinafter.)

### Supplementary Provisions

(Law No. 96, June 1, 1971)

(Extract)

(Date of Enforcement, etc.)

1. This Law shall come into force as from the day of its promulgation.  
(Omitted hereinafter.)

(Transitional Measures)

16. The application of the penal provisions to the acts committed prior to the enforcement of this Law (With regard to the provisions prescribed under each item of paragraph 1 of the Supplementary Provisions, each of the said provisions) shall be same as heretofore.

### Supplementary Provisions

(Law No. 52, June 3, 1972)

(Extract)

(Date of Enforcement, etc.)

**Article 1.** This Law shall come into force as from the day provided for by the Cabinet Order within a period not exceeding thirty (30) days from the day of its promulgation.

(Omitted hereinafter.)

(The same Law came into force as from the first of July, 1972, by the Cabinet Order No. 235 of June, 1972.)

### Supplementary Provisions

(Law No. 49, July 1, 1975)

(Date of Enforcement)

1. This Law shall come into force three (3) months after its promulgation.

(Special Provisions regarding the Order for Suspension, etc. in Case of Discovery of Remains)

2. With regard to the application of the provisions of Article 57-5 of the Law for the Protection of Cultural Properties revised by this Law (hereinafter referred to as "the new Law") for the period of five years from the day of its enforcement, "three (3) months" in the proviso to paragraph 2 of the same Article shall read "six (6) months," and "six (6) months" in the proviso to paragraph 5 of the same Article shall read "nine (9) months." In this case the dispositions under paragraph 2 of the same Article which have been made prior to the day five (5) years after the day of its enforcement shall follow the precedent under the same Article given before the said day even after the said day.

(Transitional Measures)

3. With regard to the important intangible cultural property designated under the provision of Article 56-3 paragraph 1 of the Law for the Protection of Cultural Properties before amendment under this Law (hereinafter referred to as "the former Law") at the time of the enforcement of this Law, if the Minister of Education deems it necessary to recognize holding bodies under Article 56-3 paragraph 2 of the new Law instead of the holders who have been recognized under Article 56-3 paragraph 2 of the former Law, he/she shall annul the recognition of all the holders made under the provision of Article 56-3 paragraph 2 of the former Law within the period of one year after the enforcement of this Law and newly recognize the holding

bodies under the provision of Article 56-3 paragraph 2 of the new Law. In this case the provisions of Article 56-3 paragraph 3 and Article 56-4 paragraph 3 of the new Law shall apply *mutatis mutandis*.

4. With regard to the application of the provisions of the new Law, the important material folk-culture which has been designated under the provision of Article 56-10 paragraph 1 of the former Law at the time of the enforcement of this Law shall be regarded, as the important tangible folk-cultural property designated under the provision of Article 56-10 paragraph 1 of the new Law. In this case, the certificate of designation of the important material folk-culture issued under the provision of Article 28 paragraph 3 of the former Law applying *mutatis mutandis* under Article 56-10 paragraph 2 of the former Law shall be regarded as the certificate of designation of the important tangible folk-cultural property issued under the provision of Article 28 paragraph 3 of the new Law applying *mutatis mutandis* under Article 56-10 paragraph 2 of the new Law.
5. With regard to the excavation reported prior to the enforcement of this Law under the provision of Article 57-2 paragraph 1 of the former Law, the precedent under Article 57-2 of the former Law shall be followed notwithstanding the provisions of Article 57-2 and Article 57-3 of the new Law.
6. In case of the application of the provision of Article 57-3 of the new Law to the State organs, etc. provided for in Article 57-3 paragraph 1 of the new Law which have formulated the plan of operation under the same paragraph prior to the enforcement of this Law (excluding those which have been reported under the provision of Article 57-2 paragraph 1 of the former Law concerning the execution of such plan of operation), "when the said State organs, etc. formulate the plan of operation related to the said excavation, they shall inform in advance" shall read "the said State organs, etc. shall after the enforcement of this Law inform without delay."
7. As to those which were reported as recognizable to be remains prior to the enforcement of this Law under the provision of Article 84 paragraph 1 of the former Law, the provisions of Article 84 of the former Law shall continue to be in force notwithstanding the provisions of Article 57-5 of the new Law (in case of the State organs, etc. provided for in Article 57-3 paragraph 1 of the new Law which cannot be taken as the head of the Ministry or Agency Provided for in Article 87 of the former Law, Article 57-6 of the new Law).
8. As to those which were notified prior to the enforcement of this Law as recognizable to be remains under the provision of Article 90 paragraph 1 item (8) of the former Law by the head of the Ministry or Agency provided for in Article 87 of the former Law, the provision of Article 90 paragraph 3 of the former Law applicable to the notice given under Article 90 paragraph 1 item (8) of the former Law shall continue to be in force notwithstanding the provision of Article 57-6 of the new Law.
9. The application of the penal provisions to the acts committed prior to the enforcement of this Law shall be same as heretofore.
10. Other than those provided for in the preceding seven paragraphs, transitional measures necessary for the enforcement of this Law shall be determined by the Cabinet Order.

(Partial Amendments to Relevant Laws)

11. The Ministry of Education Establishment Law (Law No. 146 of 1949) shall be partially amended as follows:  
(Omitted.)
12. The Outdoor Advertisement Law (Law No. 189 of 1949) shall be partially amended as follows:  
(Omitted.)
13. The Building Standard Law (Law No. 201 of 1950) shall be partially amended as follows:  
(Omitted.)
14. The Local Tax Law (Law No. 226 of 1950) shall be partially amended as follows:  
(Omitted.)
15. The City Planning Law (Law No. 100 of 1968) shall be partially amended as follows:  
(Omitted.)

**Supplementary Provisions**

(Law No. 78, December 2, 1983)

(Extract)

1. This Law (excepting Article 1) shall come into force as from July 1, 1984.

**Supplementary Provisions**

(Law No. 89, November 12, 1993)

(Extract)

(Date of Enforcement)

**Article 1.** This Law shall come into force as from the day of the promulgation (October 1, 1994) of the Administrative Procedures Law (Law No. 88 of 1993).

(Transitional Provisions Concerning Non-profit Dispositions into which Inquiries, etc. are Held)

**Article 2.** If, before the enforcement of this Law, there is a request by law for an inquiry or the like for which procedures should be implemented corresponding to the procedures for public hearings or to the procedures for granting opportunities to express opinions to deliberative councils and other parliamentary organs as stipulated by the Article 13 of the Administrative Procedures Law, with regard to non-profit disposition procedures related to the said request for an inquiry or the like, precedents under the former Law shall be followed notwithstanding the relevant provisions of the new Law.

(Transitional Provisions Concerning Penal Provisions)

**Article 13.** Precedents under the former Law shall be followed concerning the application of penal provisions to acts committed prior to the enforcement of this Law.

(Transitional Provisions for Arrangement of Stipulations Concerning Public Hearings)

**Article 14.** Prior to the enforcement of this Law, any audiences, inquiries or public hearings (excluding those related to non-profit dispositions) held according to law, as well as the procedures therefor, shall be regarded to have been conducted in accordance with the corresponding provision of the Laws revised by this Law.

(Cabinet Order Mandate)

**Article 15.** Other than those provided for in Supplementary Provision Article 2 through the preceding Article, transitional measures necessary for the enforcement of related laws shall be determined by Cabinet Order.

**Supplementary Provisions**

(Law No. 49, June 29, 1994)

(Extract)

(Date of Enforcement)

1. Among the Chapters of this Law, the stipulations of Chapter 1 and of the following paragraph shall come into force [ellipsis] as from the day of the promulgation (April 1, 1995) of the revised stipulations of Volume 2 Chapter 12 of the Local Government Act (Law No. 67 of 1947) among the Law Revising Part of the Local Government Act (Law No. 48 of 1994).



### Supplementary Provisions

(Law No. 97, November 11, 1994)

(Extract)

(Date of Enforcement)

Article 1. This Law shall come into force as from the day of its promulgation. (Omitted hereinafter.)

(Transitional Provisions Accompanying Partial Revision of the Law for the Protection of Cultural Properties)

Article 4. Prior to revision according to the stipulations of Article 4, offers for transfer under the stipulations of Article 46 paragraph 1 of the Law for the Protection of Cultural Properties (including cases where the same Law's Article 56-14 apply *mutatis mutandis*) as well as applications for approval under the stipulations of the proviso Article 46 paragraph 1 of the Law for the Protection of Cultural Properties (including cases where the same Law's Article 56-14 apply *mutatis mutandis*), which were made prior to enforcement of the stipulations of Article 4, shall follow precedents under the former Law, notwithstanding the stipulations of the Law for the Protection of Cultural Properties after revision according to the stipulations of Article 4.

(Transitional Provisions Concerning Penal Provisions)

Article 20. Concerning the application of penal provisions to acts committed prior to the enforcement of this Law as well as in cases where precedents under the former Law shall be followed concerning the application of penal provisions under [ellipsis] the stipulations of the Supplementary Provisions [ellipsis] Article 4 [ellipsis], to acts committed after the enforcement of the stipulations of Article 4 [ellipsis], the precedents under the former Law shall be followed.

(Cabinet Order Madate)

Article 21. Other than those provided for in Supplementary Provision Article 2 through the preceding Article, transitional measures necessary for the enforcement of this Law (including transitional measures concerning penal provisions) shall be determined by Cabinet Order.

### Supplementary Provisions

(Law No. 66, June 12, 1996)

(Extract)

(Date of Enforcement)

1. This law shall come into force as from the day provided for by the Cabinet Order within a period not exceeding nine (9) months from the day of its promulgation.

(Transitional Measures Concerning Notifications on Public Viewing of Important Cultural Properties, etc.)

2. At the time this Law comes into force, persons who have received or who have applied for permission under the stipulations of Article 53 paragraph 1 of the Law for the Protection of Important Cultural Properties prior to revision (hereinafter referred to as "the former Law"), and who are establishers of a public viewing approved institution stipulated in the proviso of Article 53 paragraph 1 of the Law for the Protection of Important Cultural Properties after revision (hereinafter referred to as "the new Law"), and who hold exhibitions and/or other events at said public viewing approved institution, shall be regarded as having made notification according to the stipulations of paragraph 2 of the same Article.

3. Before this Law comes into force, State organs or local public bodies, other than the Commissioner of the Agency for Cultural Affairs, which have given notice under the stipulations of the proviso of Article 53 paragraph 1 of the former Law, and who hold exhibitions and/or other events at public viewing approved

institutions stipulated in the proviso of Article 53 paragraph 1 of the new Law, shall be regarded as having made notification according to the stipulations of paragraph 2 of the same Article.

4. State organs or local public bodies, other than the Commissioner of the Agency for Cultural Affairs, which hold exhibitions and/or other events at a public viewing advance notification exempted institution under the stipulations of the proviso of Article 56-15 paragraph 1 of the new Law, or, among establishers of a public viewing advance notification exempted institution which hold these at said public viewing advance notification exempted institution, those which gave notice under the stipulations of Article 56-15 paragraph 1 of the former Law shall be regarded as having given notice under the stipulations of the proviso of Article 56-15 paragraph 1 of the new Law.

(Transitional Provisions Concerning Penal Provisions)

5. Precedents under the former Law shall be followed concerning the application of penal provisions to acts committed prior to the enforcement of this Law.

(Deliberations)

6. If ten (10) years have passed since the enforcement of this Law, the Japanese government shall consider the Law's implementation status, the status of cultural properties to be protected under this Law, etc., and, adding deliberations concerning systems related to the registration of tangible cultural properties, shall take necessary measures based on the results thereof.



**NATURAL PARKS LAW  
(EXCERPT)**

Promulgated on June 1, 1957

Law No.161

ENVIRONMENT AGENCY  
GOVERNMENT OF JAPAN



# NATURAL PARKS LAW (EXCERPT)

Law No.161 of 1957

Amended by Law No.140 and No.161 of 1962, No.13,

No.61 and No.140 of 1970, No.88 of 1971, and

No.52 and No.85 of 1972, and No.73 of 1973, and No.87 of 1978

Chapter	I	General Provisions (Articles 1~3)
Chapter	II	National Parks and Quasi-national Parks
	Section 1	(Articles 4~9) Delection
	Section 2	Designation (Articles 10~11)
	Section 3	Natural Park Scheme and Natural Park Work (Articles 12~6-2)
	Section 4	Protection and Utilization (Articles 17~24)
	Section 5	Expenses (Articles 25~31)
	Section 6	Miscellaneous Provisions (Articles 32~40-2)
Chapter	III	Prefectural Natural Parks (Articles 41~48)
Chapter	IV	Penal Provisions (Articles 49~54)
		Supplementary Provisions

## CHAPTER I GENERAL PROVISIONS

(Purpose)

Article 1

This Law shall aim at the protection of the places of scenic beauty and also, through the promoted utilization thereof, at the contribution to the health, recreation and culture of the people.

(Definitions)

Article 2

In this Law, the terms mentioned in the following items shall be understood respectively as laid down in the items concerned:

(1) Natural Parks shall mean National Parks, Quasi-national Parks and Prefectural Natural Parks.

(2) National Parks shall mean the places of greatest natural scenic beauty [including natural scenic beauty of sea areas (hereinafter referred to as "natural scenic beauty")], worthy of the name of the model scenic beauties of our country, designated by the Director General of the Environment Agency in accordance with the provision of Article 10 paragraph 1.

(3) Quasi-national Parks shall mean the places of great natural scenic beauty next to the National Parks, designated by the Director General of the Environment Agency in accordance with the provision of Article 10 paragraph 2.

(4) Prefectural Natural Parks shall mean the places of great natural scenic beauty designated by the prefectures in accordance with the provision of Article 41.

(5) Park Schemes shall mean the planning concerning the regulation or facilities for the protection or utilization of the National Parks or Quasi-national Parks.

(6) Park Works shall mean the works executed on the basis of the Park Scheme pertaining to the facilities, prescribed by the Cabinet Order, for the protection or utilization of National Parks or Quasi-national Parks.

(Responsibility of the State etc.)

Article 2-2

In accordance with the basic intent of Article 2 of the Nature Conservation Law (Law No. 85 of June 1972), the State, Local Public Bodies, Park Workers and Visitors of the natural parks shall make effort respectively to protect the natural scenic beauty and promote appropriate utilization.

(Respect for Property Rights and Adjustment with Public Interests)

Article 3

At the time of the application of this Law, except the provision of Article 3 of the Nature Conservation Law, the proprietary

rights, mining rights and other property rights shall be respected and also the adjustment between the land development and other public interests shall be taken into consideration.

## CHAPTER II NATIONAL PARKS AND QUASI-NATIONAL PARKS

### Section 1 (Articles 4 ~ 9) Deletion

#### Section 2 Designation

(Designation)

##### Article 10

1. The National Parks shall be designated, with specification of their boundaries, by the Director General of the Environment Agency after seeking the opinions of the Council on Nature Conservation (hereinafter referred to as "Council").
2. The Quasi-national Parks shall be designated, with specification of their boundaries, by the Director General of the Environment Agency, on the request of the prefecture concerned, after seeking the opinions of the Council.
3. In the case of the designation of the National Park or Quasi-national Park by the Director General of the Environment Agency, the fact and the area thereof shall be announced in the official gazette.
4. The designation of the National Park or Quasi-national Park shall take effect on the public announcement under the preceding paragraph.

#### Section 3 Natural Park Scheme and Natural Park Work

(Decision upon Natural Park Scheme and Natural Park Work)

##### Article 12

1. The Park Scheme and Park Work concerning the National Park shall be decided upon by the Director General of the Environment Agency after seeking the opinions of the Council.
2. Of the Park Scheme concerning the Quasi-national Park, the planning concerning the regulation for protection and the planning concerning the facilities for utilization, both relative to the developed area and the facilities prescribed by the Cabinet Order, shall be decided upon by the Director General of the Environment Agency on the request of the prefectures concerned after seeking the opinions of the Council, and the other plans shall be decided upon by the governors of the prefectures concerned.
3. The Park Work concerning the Quasi-national Park shall be decided upon by the governors of the prefectures concerned.
4. The Director General of the Environment Agency or the governor of the prefecture, when he has decided upon the Park Scheme or Park Work, shall announce the outline of the fact.

(Execution of Park Work of National Park)

##### Article 14

1. The Park Work concerning the National Park shall be executed by the State.
2. Local public bodies and other bodies prescribed under the Cabinet Order (hereinafter referred to as "the public bodies") may execute a part of the Park Work concerning the National Park upon obtaining approval from the Director General of the Environment Agency.
3. Those other than the State and public bodies may execute a part of the Park Work concerning the National Park upon obtaining authorization from the Director General of the Environment Agency.

(Execution of Park Work under Approval or Authorization)

##### Article 16

As to the procedures of the approval or authorization under the provisions of the preceding two articles and the execution of the Park Work with the same approval or authorization, the necessary matters shall be prescribed by the Cabinet Order.

(Maintenance of Cleanliness)

##### Article 16-2

The Government and Local Public Bodies shall, when deemed necessary, cooperate with the personnel responsible for the administration of the roads, picnic grounds, camping grounds, sky slopes, swimming areas, and other public use sites located in National and Quasi-national Parks in the maintenance of the cleanliness of such facilities.

#### Section 4 Protection and Utilization

(Special Area)

##### Article 17

1. The Director General of the Environment Agency may, for the purpose of preserving scenic beauty of the National Park or Quasi-national Park, designate the Special Area within its boundary (excluding sea areas) in accordance with the Park Scheme.
2. The provisions of Article 10 paragraphs 3 and 4 shall be applied correspondingly to the designation of the Special Area and dissolution of its designation, and to the alteration of its boundary.
3. Within the Special Area (with the exception of the Specially Protective District; hereinafter the same in this article), the work coming under any of the following items shall not be carried out without the permission from the Director General of the Environment Agency in case of the National Park and that from the governor of the prefecture in case of the Quasi-national Park; provided that the work, that has already been under way at the time of the designation of the Special Area concerned or the expansion of its boundary, or the work carried out for the emergency measure shall

be excepted from the rule:

- (1) Erection, rebuilding or extension of structures;
  - (2) Felling of trees and bamboos;
  - (3) Mining of minerals or gathering of soils and stones;
  - (4) Acts or works causing the increase or decrease of the water level or quantity of water of rivers, lakes, etc;
  - (4)-2 Discharging polluted or waste water through the sewage disposal facilities into the lakes, marshes or moist grassland designated by the Director General of the Environment Agency or within a distance of one kilometer from there discharging the same through the sewage disposal facilities into the water running into the designated lakes, etc.
  - (5) Putting up or setting up of advertisements or those similar to them, or showing of advertisements or those similar to them on the structures and the like;
  - (6) Reclamation of the surface of water or land reclamation by drainage;
  - (7) Clearing of land or other changing of the feature of land;
  - (8) Gathering of alpine plants or plants similar to them, which are designated by the Director General of the Environment Agency;
  - (9) Alteration of the colours of roofs, surface of walls, fence and walls, bridges, steel towers, water-pipes or those similar to them.
4. One, who has already started the work mentioned in any of the items of the preceding paragraph within the Special Area at the time of the designation of the Special Area concerned or the expansion of its boundary, shall notify the fact to the governor of the prefecture within 3 months counting from the day of the designation of it or expansion of its boundary.
5. One, who has already started the work mentioned in any of the items of paragraph 3 within the Special Area as the necessary emergency measure for the exceptional disaster, shall notify the fact to the governor of the prefecture within 3 months counting from the day of the work carried out.
6. One, who intends to plant trees and bamboos or pasture cattle within the Special Area, shall previously notify the fact to the governor of the prefecture.
7. To the works mentioned in any of the following items, the provisions of the preceding 4 paragraph shall not be applied:
- (1) The work carried out as the execution of the Park Works;
  - (2) Ordinary administrative work, simple work or other, that are prescribed by the Ordinance of the Prime Minister's Office.

(Special Protection Area)

Article 18

1. The Director General of the Environment Agency, when he deems it specially necessary for the preservation of the spectacular sights of the National Park or Quasi-national Park, may designate

the Special Protection Area within the Special Area in accordance with the Park Scheme.

2. The provisions of Article 10 paragraphs 3 and 4 shall be applied accordingly to the designation of the Special Protection Area and dissolution of the designation thereof, and to the alteration of the boundary thereof.

3. Within the Special Protection Area the following works shall not be carried out without the permission from the Director General of the Environment Agency in the case of the National Park and without that from the governor of the prefecture in the case of the Quasi-national Park; provided that the work has already been under way at the time of the designation of the Special Protection Area concerned or the expansion of the boundary thereof, or the work carried out as the necessary emergency measure for the exceptional disaster shall be excepted from the rule.

- (1) Work mentioned in any of the items of paragraph 3 of the preceding article;
- (2) Planting of trees and bamboos;
- (3) Pasturing of cattle;
- (4) Accumulation or storage of things in the open;
- (5) Setting fire or making fire;
- (6) Gathering of plants or fallen leaves, or fallen branches;
- (7) Catching of animals or gathering of eggs of animals;
- (8) Riding a horse or driving a car into the area other than road or plaza.

4. One, who has already started the work mentioned in any of the items of the preceding paragraph within the Special Protection Area at the time of the designation of the Special Protection Area concerned or the expansion thereof, shall notify the fact to the governor of the prefecture within 3 months counting from the day of the designation of it or expansion of its boundary.

5. One, who has carried out the work mentioned in any of the items of paragraph 3 within the Special Protection Area as the necessary emergency measure for the exceptional disaster, shall notify the fact to the governor of the prefecture within 14 days counting from the day of the same work carried out.

6. To the works or acts mentioned in the following items, the provisions of the preceding 3 paragraphs shall not be applied.

- (1) The work carried out as the execution of the Park Works;
- (2) Ordinary administrative work, insignificant work or other works that are prescribed by Ordinance of the Prime Minister's Office.



(Conditions)

Article 19

To the permissions under Article 17 paragraph 3 and paragraph 3 of the preceding article, conditions may be attached within the limits necessary for the protection of the scenic beauty or spectacular sight of the National Park or Quasi-national Park.

(Ordinary Area)

Article 20

1. Those intending to undertake any of the activities mentioned below in areas of National or Quasi-national Parks other than Special Areas or Marine Park Areas (hereinafter referred to as "Ordinary Areas") must notify the sort of act, the place, the means, the pre-arranged date, and others stipulated by ordinance of the Prime Minister's office to the prefectural governor of such intent before undertaking the activity. This shall not apply, however, to activities mentioned in items (1), (3), (5) and (6) which are necessary for fishery operations such as setting up fishing gear.

(1) Erection, rebuilding or extension of structures, whose scale are beyond the standards prescribed by the Ordinance of the Prime Minister's Office (including rebuilding or extension in the case that the scale thereof is to be beyond the standards prescribed by the Ordinance of the Prime Minister's Office after the completion of the rebuilding or extension concerned);

(2) Causing the increase or decrease of the water-levels or quantities of the rivers or lakes within the same Special Area;

(3) Putting up or setting up of advertisements or those similar to them or showing of advertisements or those similar to them on the structures;

(4) Reclamation of the sea or land reclamation by drainage;

(5) Mining of minerals or gathering of soil and stones within one kilometer of the Marine Park Area;

(6) Changing the feature of the seabed within one kilometer of the Marine Park Area.

2. The Director General of the Environment Agency and the governor of the prefecture, when the former in the case of National Parks and the latter in the case of Quasi-national Parks deem it necessary for the protection of the landscapes of the parks concerned, may give orders, to the one who is going to do or has done the work mentioned in any of the items of the preceding paragraph in the Ordinary Area, to prohibit or restrict such work or to take necessary measure, within the limits necessary for the protection of the landscapes thereof.

3. As to one who has made the notification under paragraph 1, the measure under the preceding paragraph may be taken exclusively within 30 days counting from the day of the same notification made.

4. The Director General of the Environment Agency or the

governor of the prefecture, when, with the notification made under paragraph 1, the on-the-spot survey is required or when there is any other rational reason against the measure under paragraph 2 to be made within the period of time under the preceding paragraph, may prolong the period of time under the preceding paragraph during the period of existence of such reason. In this case, one, who has made the notification under paragraph 1, shall be notified of the fact and reason why the period of time is prolonged.

5. To the works mentioned in the following items, the provisions of paragraphs 1 and 2 shall not be applied.

(1) The work carried out for the execution of the Park Works;

(2) Ordinary administrative works, insignificant works or other works which are prescribed by the Ordinance of the Prime Minister's Office;

(3) Works which have already started at the time of the designations of National Parks, Quasi-national Parks or Marine Park Areas or the expansion of the boundaries thereof;

(4) Works carried out as the emergency measures necessary for exceptional disasters.

(Order for Restoration to Original State, etc.)

Article 21

The Director General of the Environment Agency in regard to the National Parks or the governor of the prefecture in regard to the Quasi-national Parks, when he deems it necessary for the protection of the respective parks concerned, may give orders to those who have violated the provision of Article 17 paragraph 3 or Article 18 paragraph 3, the conditions attached to the permission under the provision of Article 19 or the measure in accordance with the provision of paragraph 2 of the preceding article, for the restoration to the original state or, in the case of the remarkable difficulty in the restoration to the original state, for the necessary measures to be taken as the substitutes therefor, both within the limits necessary for the protection thereof.

(Developed Area)

Article 23

1. For the purpose of consolidating in groups the facilities for the utilization of the National Park or Quasi-national Park, the Director General of the Environment Agency shall designate the Developed Area within its boundary in accordance with the Park Scheme.

2. The provisions of Article 10 paragraphs 3 and 4 shall be applied correspondingly to the designation and dissolution of the designation of the Developed Area and the alteration of its boundary.

(Regulation for Utilization)

Article 24

1. Within the Special Area of the National and Quasi-national

Parks, Marine Park Areas or Developed Area, no one shall perform the acts mentioned in the following items:

- (1) Dumping refuse and other filth or waste or leaving them as they are in such manners as give remarkably unpleasant feelings to those utilizing the National Park or Quasi-national Park concerned;
  - (2) Letting remarkably offensive odors exhale, sending out disturbing noises with loud speakers, radios, etc., occupying waywardly observation points, pavillions, etc., touting in such manners as cause one to feel sickening, or else causing annoyance to those utilizing the National Park or Quasi-national Park concerned.
2. The competent personnel of the State or of the prefecture, when any one is found performing the act mentioned in item 2 of the preceding article within the Special Area or Developed Area, may give instructions to stop the act.
  3. The personnel provided for in the preceding paragraph shall carry identification papers with them and present them at the request of interested party.

#### CHAPTER IV PENAL PROVISIONS

##### Article 49

Any one, who has violated the order under the provision of Article 21, shall be punished with a penal servitude of not more than 1 year or a fine of not more than 200,000 yen.

##### Article 50

Any one, who comes under any of the following items, shall be punished with a penal servitude of not more than 6 months or a fine of not more than 100,000 yen:

- (1) One who has violated the provision of Article 17 paragraph 1 or Article 18 paragraph 3 or Article 18-2 paragraph 3.
- (2) One who has violated the conditions attached to the permission in accordance with the provision of Article 19.

##### Article 51

Any one, who has violated the measure taken under the provision of Article 20 paragraph 2, shall be punished with a fine of not more than 100,000 yen.

##### Article 52

Any one, who comes under any of the following items, shall be punished with a fine of not more than 50,000 yen:

- (1) One who does not make the notification under the provision of Article 20 paragraph 1 or has made false notification;
- (2) One who has violated the provision of Article 20 paragraph 5;
- (3) One who does not make the reporting under Article 21 paragraph 1 or has made false reporting;
- (4) One who has denied, prevented or evaded the entering

inspection or entering survey under the provision of Article 22 paragraph 2;

(5) One who has performed, without permission, the acts or works mentioned in Article 24 paragraph 1 item 1 within the Special Area, Marine Park Area or Developed Area of the National Park or Quasi-national Park;

(6) One who has performed, without permission, the acts mentioned in paragraph 1 item 2 of the same article without obedience to the direction of the competent personnel under the provision of Article 24 paragraph 2 within the Special Area, Marine Park Area or Developed Area of the National Park or Quasi-national Park;

(7) One who, violating the provision of Article 32 paragraph 5, has denied or prevented the entry or setting up of land marks or other works or acts under the provision of paragraph 1 of the same article.



**Nikko Municipal Ordinance Concerning Townscape (Excerpt)**

(March 22, 1985, Nikko Municipal Ordinance Number 1)  
(Amended on March 19, 1998)



# Nikko Municipal Ordinance Concerning Townscape

(March 22, 1985, Nikko Municipal Ordinance Number 1)

(Amended on March 19, 1998)

## Contents

### Chapter 1. General Provisions

Section 1. Purpose and Definitions (Article 1 and Article 2)

Section 2. Obligations of Mayor (Articles 3 - 6)

Section 3. Obligations of Citizens, Corporations and Experts (Articles 7 - 9)

Chapter 2. Townscape Formation Zones (Articles 10 - 15)

Chapter 3. Citizens' Organization for Townscape Formation (Articles 16 -18)

Chapter 4. Financial Supports etc. (Articles 19 -21)

Chapter 5. Nikko City Townscape Council (Article 22 and Article 23)

Chapter 6. Miscellaneous Provisions (Articles 24 - 28) (omitted)

Supplementary Provisions (omitted)

## Chapter 1. General Provisions

### Section 1. Purpose and Definitions

#### (Purpose)

Article 1. The purpose of this ordinance is to preserve, cultivate and produce townscape unique to Nikko and thereby to make Nikko a more attractive, familiar and proud city for citizens of Nikko by establishing necessary provisions for the maintenance of scenic beauty and sound formation of townscape founded upon historical backgrounds and local individuality of Nikko.

#### (Definitions)

Article 2. The following words and terms have the following meanings for the purpose of this ordinance, unless the context indicates otherwise:

- (1) formation of townscape. "Formation of townscape" means to preserve, cultivate and create townscape unique to Nikko;
- (2) buildings. "Buildings" means buildings defined in Article 2 item (1) of the Building Standard Law (Law No. 201 of 1950) and other structures specified in the enforcement regulations;
- (3) corporation. "Corporations" means those who undertake construction of buildings.
- (4) experts. "Experts" means those who are professionally engaged in design or construction of buildings.

Section 2. Obligation of Mayor

**(Basic Obligation of Mayor)**

Article 3. The mayor shall plan and enforce basic, comprehensive measures to accomplish the purpose of this ordinance.

2. The mayor, when he/she intends to plan or enforce the measures pursuant to the provision of the preceding paragraph, shall make every effort to reflect the opinions of citizens, corporations and experts.

**(Basic Plan)**

Article 4. The mayor shall make the Basic Townscape Formation Plan which manifests the basic direction to be followed with regard to the sound formation of townscape.

**(Role as a Leader)**

Article 5. The mayor, when he/she newly constructs, maintains or modifies public facilities such as roads, parks etc. or intends to undertake public works such as river projects etc., shall not only coordinate them with the Basic Townscape Formation Plan but also make every effort to play the role of a leader in the sound formation of townscape.

**(Enlightenment)**

Article 6. The mayor shall take necessary measures to enhance the awareness of citizens, corporations and experts with regard to the sound formation of townscape.

Section 3. Obligations of Citizens, Corporations and Experts

**(Obligations of Citizens, Corporations and Experts)**

Article 7. Citizens, corporations and experts, shall make every effort to contribute to the sound formation of townscape from their standpoints by enhancing their own awareness with regard to the sound formation of townscape.

**(Obligations to Cooperate)**

Article 8. Citizens, corporations and experts

2. Citizens, corporations and experts shall cooperate with each other in order to contribute to the sound formation of townscape.

**(Obligations to Pay Consideration to the Sound Formation of Townscape)**

Article 9. Citizens, corporations and experts shall give careful consideration to the sound formation of townscape when they intend to newly construct, remodel or enlarge buildings or

to repair or change the exterior of the buildings or to change it either in design or in color or when they intend to change the land configuration.

## **Chapter 2. Townscape Formation Zones**

### **(Designation of Townscape Formation Zones)**

Article 10. The mayor shall designate areas which he/she deems essential to the sound formation of townscape as Townscape Formation Zones.

2. Areas listed below shall be designated as Townscape Formation Zones:

- (1) areas where townscape unique to Nikko is formed along the roads or rivers;
- (2) areas where traditional buildings and other structures as a unit are forming townscape unique to Nikko;
- (3) areas where residences and commercial facilities as a unit are forming townscape unique to Nikko;
- (4) areas to be improved for the sound formation of townscape;
- (5) other areas which the mayor deems essential to the sound formation of townscape.

3. The mayor, when he/she intends to designate Townscape Formation Zones, shall take measures to inform the public of the intention such as public announcement, public review and explanation meetings, and request for the opinions of citizens etc.

4. The mayor, when he/she has designated Townscape Formation Zones, shall make public announcement of the fact.

5. The provisions of paragraph 3 to the preceding paragraph shall also apply *mutatis mutandis* to alteration of Townscape Formation Zones.

### **(Townscape Formation Standards)**

Article 11. The mayor, when he/she has designated Townscape Formation Zones under the provision of paragraph 1 of the preceding article, shall set the standards for the sound formation of townscape of each area (hereinafter referred to as "Townscape Formation Standards").

2. Townscape Formation Standards shall set standards as regards necessary matters selected from those listed below:

- (1) size and location of buildings in the premises;
- (2) color and design of buildings;
- (3) exterior form of buildings;
- (4) land configuration;
- (5) appearance of trees or bamboo;
- (6) any other item the mayor deems necessary to the sound formation of townscape.



3. The mayor, when he/she has set the Townscape Formation Standards, shall make public announcement of the fact.

4. The provisions of the preceding paragraph shall apply *mutatis mutandis* to alteration of the Townscape Formation Standards.

**(Actions which Require Advance Notifications)**

Article 12. A person who intends to conduct any of the actions listed below within a Townscape Formation Zone shall submit an advance notification of the content of the action to the mayor in accordance with the procedures prescribed in the enforcement regulations.

(1) Actions to newly construct, remodel, enlarge, relocate or remove buildings or to repair the exterior of buildings or change it in design on a large scale or change it in color on a large scale;

(2) Actions to change the land configuration or to fell trees or bamboo, which are specified in the enforcement regulations;

(3) Any other actions the mayor deems it necessary to restrict which are specified in the enforcement regulations.

2. Notwithstanding the provision of the preceding paragraph, the actions, which are specified in the enforcement regulations, such as actions for day-to-day management or actions of insignificant impact do not require advance notifications.

**(Observations of Townscape Formation Standards)**

Article 13. A person who intends to conduct any of the actions listed in paragraph 1 of Article 12 shall make every effort to observe the Townscape Formation Standards.

**(Advice or Instruction Based on Townscape Formation Standards)**

Article 14. The mayor, when he/she has received the notification, submitted under the provision of paragraph 1 of the preceding article, of the action which he/she deems does not conform to the Townscape Formation Standards, may advise or instruct the person who submitted the notification to take necessary measures.

2. The mayor may consult the Nikko City Townscape Council when he/she gives advice or instruction under the provision of the preceding paragraph.

**(Advice or Instruction Regarding Open Space)**

Article 15. The mayor, when he/she finds that an open space in a Townscape Formation Zone disturbs the townscape of the area in question, may advise or instruct the person who owns or administrates the open space to manage or utilize the open space in consideration of the sound

formation of townscape.

2. The provision of paragraph 2 of the preceding article shall apply *mutatis mutandis* when the mayor gives advice or instruction under the provision of the preceding paragraph.

### Chapter 3. Citizens' Organizations for Townscape Formation

#### **(Designation of Citizens' Organizations for Townscape Formation)**

Article 16. The mayor may designate groups of citizens organized for the purpose of contributing to the sound formation of townscape as Citizens' Organizations for Townscape Formation, when they satisfy the conditions listed below:

- (1) the activities of the group should be conducted only in the land, buildings and other structures which members of the group own, manage and use;
- (2) the activities of the group should not unduly obstruct the exercise of the property right;
- (3) the activities of the group should be approved by the majority of residents in the relevant area;
- (4) other conditions which are specified in the enforcement regulations should be also satisfied.

#### **(Application of Designation of Citizens' Organizations for Townscape Formation)**

Article 17. A group of citizens which intends to be designated as a Citizens' Organization for Townscape Formation shall apply in accordance with the procedures prescribed in the enforcement regulations.

#### **(Cancellation of Designation of Citizens' Organizations for Townscape Formation)**

Article 18. The mayor, when he/she recognizes the fact that a group designated as a Citizens' Organization for Townscape Formation under the provision of Article 16 has not conformed to items of the same article any longer or the group does not suit the purpose of the designation for any other reasons, shall cancel the designation of the group as a Citizens' Organization for Townscape Formation.

### Chapter 4. Financial Supports etc.

#### **(Financial Supports Concerning Townscape Formation Zones)**

Article 19. The mayor may financially support the person who he/she acknowledges conducts actions necessary for the sound formation of townscape in a Townscape Formation Zone by granting or loaning part of the cost to the person.

**(Financial Supports to Citizens' Organization for Townscape Formation)**

Article 20. The mayor may give technical support to Citizens' Organizations for Townscape Formation or support them financially by granting them the subsidy to cover part of the cost necessary for their activities.

**(Measures Concerning Buildings Including Financial Supports)**

Article 21. The mayor may take adequate measures concerning the management, repair, landscaping or restoration of the buildings or other structures which he/she acknowledges especially necessary for the sound formation of townscape. Otherwise, the mayor may give technical support to the owners of such buildings or other structures or support them financially by granting them the subsidy to cover part of the cost necessary for their activities.

**Chapter 5. Nikko City Townscape Council**

**(Establishment of Nikko City Townscape Council)**

Article 22. The mayor shall have the Nikko City Townscape Council (hereinafter referred to as the Council).

2. The Council shall, when consulted by the mayor, investigate and deliberate on basic matters or important matters concerning the sound formation of townscape.

**(Organization and Operation)**

Article 23. Necessary matters concerning organization and operation of the Council are specified in the enforcement regulations.

**Chapter 6. Miscellaneous Provisions**

Articles 24-28. (omitted)

Supplementary Provisions (omitted)

**The Preservation Management Plan for the Nikko Sannai Historic Site  
(Excerpt)**



The Preservation Management Plan for the Nikko Sannai Historic Site (Excerpt)

	Zone A	Zone B	Zone C	Zone D	Zone E
Characteristics of the zone	Historically significant buildings designated as National Treasures and Important Cultural Properties and shrine forests are located in this zone.	Buildings and open space located in this zone are significant as the stage for religious activities.	Facilities for presentation of cultural assets or facilities for repair of cultural assets are located in this zone together with residences and utilities including car parking.	This zone consists of forests which form the principal part of the natural landscape in the Sannai area.	This zone consists of roads and streets, mainly under the management of the local government of Nikko City..
Policy of preservation of the zone	No alteration to the existing state is permitted, as a rule.	Religious activities should be coordinated with the value of the Historic Site.	The management of the Historic Site should be coordinated with the daily lives of residents.	No alteration to the existing state is permitted, as a rule.	Due consideration should be paid to the value of the overall Historic Site.
Policy of response to the needs for development such as actions to newly construct, remodel, enlarge or remove buildings and other structures, to change the land configuration and to fell trees or bamboo.	No alteration to the existing state is permitted, as a rule.  Actions listed below are permitted only when they have no impact on the value of the Historic Site: <ul style="list-style-type: none"> <li>· actions for the management of the shrines and temples,</li> <li>· actions for the public interests,</li> <li>· actions for the management of the Historic Site,</li> <li>· actions for academic purposes.</li> </ul>	Only actions necessary for the management of the shrines and temples or the public interests are permitted, as a rule.  Actions listed below are permitted only when they have no impact on the value of the Historic Site: <ul style="list-style-type: none"> <li>· actions for the management of the Historic Site,</li> <li>· actions for academic purposes,</li> <li>· actions to change the land configuration or felling of trees and bamboo associated with the conservation repair work of the precincts or front approaches.</li> </ul>	Only actions which have no impact upon preservation of the value of the Historic Site are permitted, as a rule.  Actions listed below are permitted only when they are necessary for the management of the shrines and temples or for the public interests: <ul style="list-style-type: none"> <li>· actions to newly construct, remodel or enlarge buildings.</li> </ul>	No alteration to the existing state is permitted, as a rule.  Actions listed below are permitted only when they have no impact on the value of the Historic Site: <ul style="list-style-type: none"> <li>· actions necessary for the management of the shrines and temples or for the public interests,</li> <li>· actions to fell trees or bamboo.</li> </ul>	No alteration to the existing state is permitted, as a rule.  Actions listed below are permitted only when they have no impact on the value of the Historic Site: <ul style="list-style-type: none"> <li>· actions to improve the existing roads,</li> <li>· actions for preservation or repair of stone walls.</li> </ul>
Requirement for excavation for investigation	Excavations are to be conducted when it is judged necessary before alteration to the existing state. Necessary archeological excavations are to be conducted.			Excavation is to be conducted when necessary.	Excavations are to be conducted when it is judged necessary before alteration to the existing state. Necessary archeological excavations are to be conducted.
Policy of construction of support facilities	No alteration to the existing state is permitted, as a rule.	Preservation should be coordinated with the management of the shrines and temples, as a rule.	Protection and utilization of the Historic Site should be coordinated, as a rule.	No alteration to the existing state is permitted, as a rule. Adequate measures for forest management should be taken.	No alteration to the existing state is permitted, as a rule. Adequate measures should be taken for the improvement of front approaches to the shrines and temples.
Requirement for landscape conservation	Due consideration should be paid to landscape conservation in terms of the value of the Historic Site.			Due consideration should be paid to the conservation of the natural environment in terms of the value of the Historic Site.	Due consideration should be paid to landscape conservation in terms of the value of the Historic Site.
Procedure of application for permission	1. Advanced consultation with the Nikko Municipal Board of Education (and other relevant organizations) 2. Submission of 3 copies of application forms for the permission of alteration to the existing state to the organization with permitting authority. (No permission is required for day-to-day management or in case of emergency.)				
Organizations with permitting authority	The Agency for Cultural Affairs (and the Tochigi Prefectural Board of Education for matters entrusted concerning the management of the Special Protection Area of Nikko National Park etc.)				



# Map indicating the extent of Nikko Sannai Historic Site

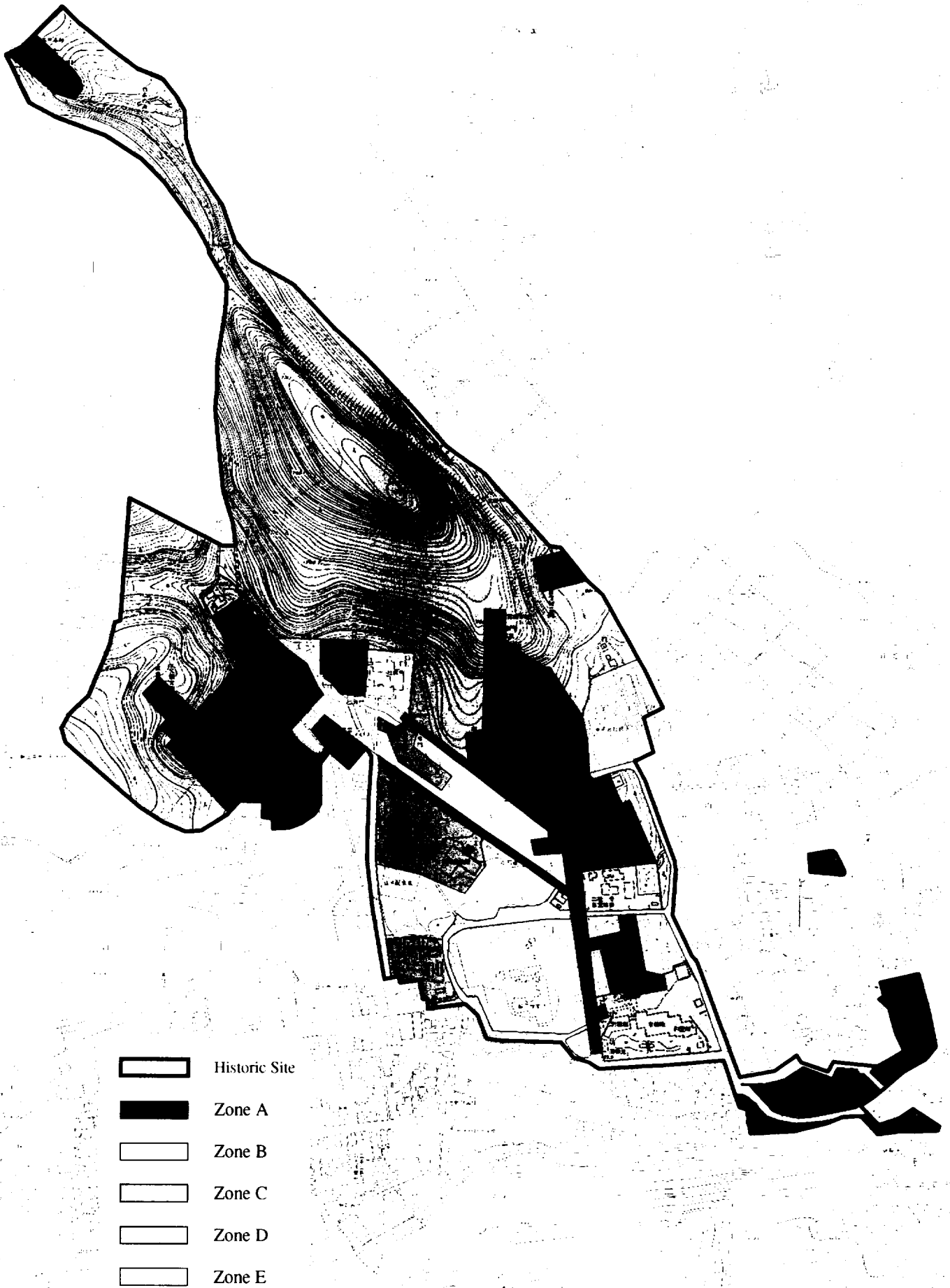



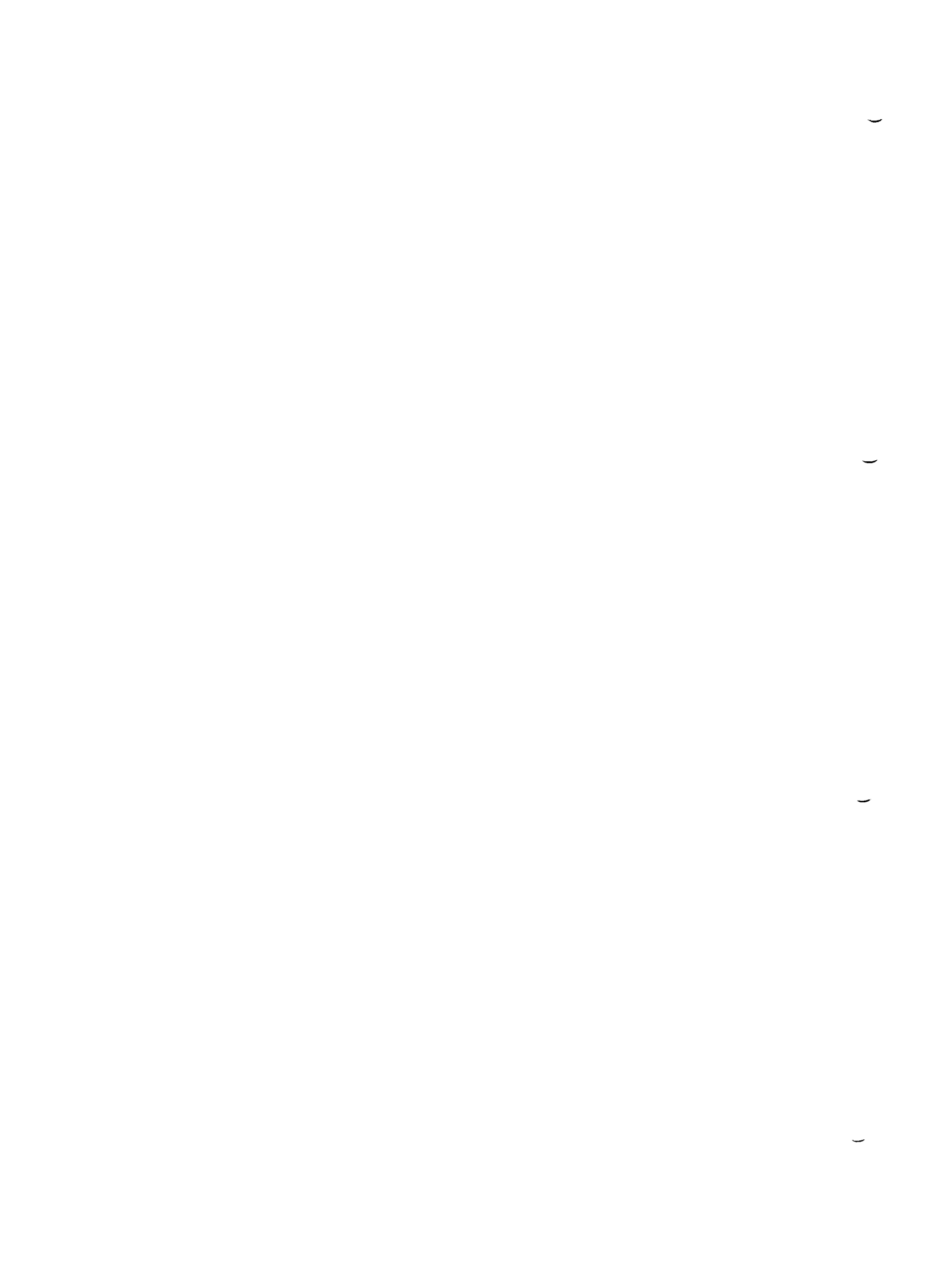

The Management Plan for Nikko National Park\*  
Nikko District (Summary)

November 1996

Nature Conservation Bureau  
Environment Agency, Government of Japan  
and  
North-Kanto Regional National Parks and Wildlife Office

※ This document is a provisional translation prepared for the nomination of Shrines and Temples of Nikko for inscription on the World Heritage List.



## Guidelines of Management in the Nikko Management Area

### (1) Guidelines of Management

Management measures shall be taken in the Nikko management area\* in accordance with the guidelines listed below:

- ① Conservation of the historical landscape produced by the shrines and temples of Nikko and the natural landscape surrounding them.
- ② Enhancement of the amenities of residential areas and the scenic beauty along roads and trails.
- ③ Co-existence with wildlife.

### (2) Control of Actions Which Require Permission or Notification

Actions regulated in the Special Areas of Nikko National Park under the Natural Parks Law shall be further controlled in the Nikko management area in accordance with the guidelines listed below in addition to generally imposed restrictions in the Special Areas or the Special Protection Area of national parks.

Actions regulated in the Ordinary Area of Nikko National Park under the Natural Parks Law shall be further controlled in the Nikko management area in accordance with the guidelines listed below (except for those pertaining to scales of buildings) in addition to generally imposed restrictions in the Ordinary Area of national parks. (Additional guidelines for the construction of buildings in the Ordinary Area is given in Annex Table 1.)

#### ① Additional guidelines for the construction of buildings

##### i) Sannai area

- Buildings should be designed in consideration of the historical landscape around the shrines and temples of Nikko.
- The roof should be slanted as in gabled roofs or hipped roofs, and should be finished, when possible, in the Japanese style.

##### ii) Rest of the management area

- The roof should be slanted as in gabled roofs or hipped roofs. As a rule, the roof gradient should be between 2/10 and 5/10; the color of roofs should be coordinated based on a color palette consisting of brown or gray with low intensity.
- The color of the exterior should be coordinated based on a color palette consisting of cream, beige, brown or gray with low intensity.
- Buildings should be set back as far from the national roads as possible. Due consideration should be paid to the conservation of trees planted along the national roads; trees or other plants should be planted to mitigate the visual impacts when necessary.

#### ② Additional guidelines for the construction of automobile roads

##### i) Sannai area

- Due consideration should be paid to the conservation of the historical landscape and the safety of

---

\* See the attached map for the extent of the total management area and the extent of the Sannai area.

pedestrians.

- Roads and guardrails should be coordinated with historical stone structures such as stone-bedded streets and stone pillars in the district of special significance for the historical landscape, unless it impairs traffic safety.
- Vegetation stripped in the process of construction work should be compensated, as a rule, by planting in-kind vegetation on the site.
- Retaining walls should be finished in consideration of existing stone walls in the district of special significance for the historical landscape. In the rest of the Sannai area, retaining walls visible from frequently used spots should be finished, as a rule, with naturally produced stone or imitation stone.
- Surplus soil produced as a result of construction work should be dealt with adequately in a location with no impact in terms of visual aspects of the national park.

ii) Rest of the management area

- Cutting of trees or alteration to the existing landform should be minimized in consideration of the conservation of natural environment and habitats for wildlife. Trees or other plants should be planted to mitigate visual impacts when necessary.
  - Guardrails visible from frequently used spots should be colored brown or gray -- and rendered lusterless, for instance with zinc plating -- unless it impairs traffic safety.
  - Metal parts of fences or bridges visible from frequently used spots should be colored brown or gray and rendered lusterless, for instance with zinc plating.
  - Vegetation stripped in the process of construction work should be compensated, as a rule, by planting in-kind vegetation on the site.
  - Pavement of the roads that have come out of use as a result of construction of new roads should be removed and instead vegetation of the same kind as grows naturally in the area should be planted.
  - Retaining walls visible from frequently used spots should be finished, as a rule, with wood, naturally produced stone or their imitations.
  - Surplus soil produced as a result of construction work should be dealt with adequately in a location with no impact in terms of visual aspects of the national park.
- ③ Additional guidelines for the construction of telephone poles, electric light poles etc.
- In the Sannai area, telephone poles etc. should be designed in consideration of the historical landscape; electricity wires or telephone lines should be put underground or behind buildings.
  - The color of the pole should be coordinated based on brown.
  - The number of telephone poles etc. should be minimized.
  - No advertisements or notices should be placed on telephone poles etc.
- ④ Additional guidelines for the construction related to sand erosion control etc.
- Due consideration should be paid to the protection of scenic beauty and wildlife; dams or other facilities should be incrustated with wood or naturally produced stone and equipped with fishways when necessary.
- ⑤ Additional guidelines for the installation of vending machines

- Vending machines are permitted to be installed only by the side of buildings. No vending machines are permitted to be installed independently along the roads.
- The color of the vending machine should be coordinated with that of the adjoining building.
- Adequate measures should be taken for disposal of empty cans.

⑥ Additional guidelines for the installation of advertisements etc.

i) Sannai area

- Advertisements should be designed in consideration of the historical landscape.
- The number of advertisements should be minimized.
- As a rule, the materials of advertisement equipment should be chosen from natural materials such as wood and naturally produced stone.
- The color of advertisement equipment should be coordinated on black, brown or natural colors of wood or stone. The color of words should be black or white, as a rule.
- The content of advertisement should be strictly limited to the permitted subject. No accessory advertisement such as names of sponsors is permitted.
- When lighting equipment is installed, advertisements should be lit by remote lighting equipment such as white spotlight.
- Adequate measures for management should be taken to repair or remove damaged advertisements or to keep advertisements clean.

ii) Rest of the management plan area

- The number of advertisements should be minimized.
- As a rule, the materials of advertisement equipment should be chosen from natural materials such as wood and naturally produced stone.
- The color of advertisement equipment should be coordinated on black, brown or natural colors of wood or stone.
- The content of advertisement should be strictly limited to the permitted subject. No accessory advertisement such as names of sponsors is permitted.
- When lighting equipment is installed, advertisements should be lit by remote lighting equipment such as white spotlight.
- Adequate measures for management should be taken to repair or remove damaged advertisements or to keep advertisements clean.

⑦ Additional guidelines for the protection of animals and plants (omitted).

(3) Park Works

Park Works prescribed in Article 2 item (6) of the Natural Parks Law shall be conducted in the Nikko management area, as a rule, in accordance with the guidelines listed below in addition with ordinary guidelines for Park Works.

① Additional guidelines for the construction of automobile roads executed as part of Park Works

- Due consideration should be paid to the preservation of habitats of wildlife and the protection of vistas and scenic beauty along the road.
- Guardrails should be colored brown or gray -- and rendered lusterless, for instance with zinc plating -- unless it impairs traffic safety.
- Metal parts of fences or bridges should be colored brown or gray and rendered lusterless, for instance with zinc plating.
- Vegetation stripped in the process of construction work should be compensated, as a rule, by planting in-kind vegetation on the site.
- Pavement of the roads that have come out of use as a result of construction of new roads should be removed and instead vegetation of the same kind as grows naturally in the area should be planted.
- Retaining walls should be finished, as a rule, with wood, naturally produced stone or their imitations.
- Surplus soil produced as a result of construction work should be dealt with adequately in a location with no impact in terms of visual aspects of the national park.

② Additional guidelines for the construction of walking trails executed as part of Park Works.

- Due consideration should be paid to securing the safety and amenity of walking trails. At the same time, walking trails should be designed to lead visitors to deeper understanding of history and nature.
- Adequate signs should be installed in order to keep visitors on the right course.
- In the Sannai area, signs should be designed in consideration of traditional stone signposts.
- Adequate measures should be taken to secure vistas for walking trails intended as viewpoints unless they impair the scenic beauty or the natural environment.
- Installation of dustbins should not be permitted without adequate management including planned collection of dust. Dustbins should be designed and installed in consideration of impacts upon scenic beauty and wildlife.

③ Additional guidelines for the construction of accommodations executed as part of Park Works.

- In the Sannai area, buildings for accommodation should be designed in the traditional Japanese style in consideration of the shrines and temples of Nikko.
- The height of newly constructed buildings should be 13 m or less. No multi-storied buildings with four stories or more should be newly constructed.
- The roof should be slanted as in gabled roofs or hipped roofs. As a rule, the roof gradient should be between 2/10 and 5/10.
- The color of roofs should be coordinated based on a color palette consisting of brown or gray with low intensity and chosen so as not to break the chromatic continuity with other buildings.
- The color of the exterior should be coordinated based on a color palette consisting of cream, beige, brown or gray with low intensity.
- Buildings should be set back as far from the roads as possible. Trees or other plants should be planted to mitigate the visual impacts.

- The number of advertisements should be minimized. The installation of advertisements should be limited to the premises of the accommodation facilities. When advertisements are installed on walls of the accommodation facilities, they should be on the lower side of the wall. In addition, the provisions of Chapter 2, 2, (1), ⑥ concerning the materials, colors etc. should be also observed.

Annex Table 1. Additional guidelines for the construction of buildings in the Ordinary Area

Structure of buildings	Building height limit	25 m
	Building coverage limit	30 % *
	Minimum set back distance	5 m from the boundary of the building lot*; 20 m from the street*
	Visual impact	Buildings shall not have significant impact upon views from major viewpoints.
Design of buildings	Color	The roof and exterior shall be colored in accordance with the surrounding nature.
	Form	No roof that is conspicuously discordant with the surrounding nature shall be chosen.
Green open space	Conservation	The existing trees in the remnant lot shall be preserved on the site, as a rule.
	Vegetation recovery	The remnant lot shall be planted with trees.
	Minimum open space coverage	40 %*

Notes: asterisked items of the guidelines shall not apply to Land Use Districts designated under the City Planning Law.



(Map indicating the extent of the Sannai area in the Nikko management area.)

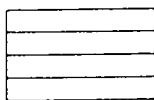
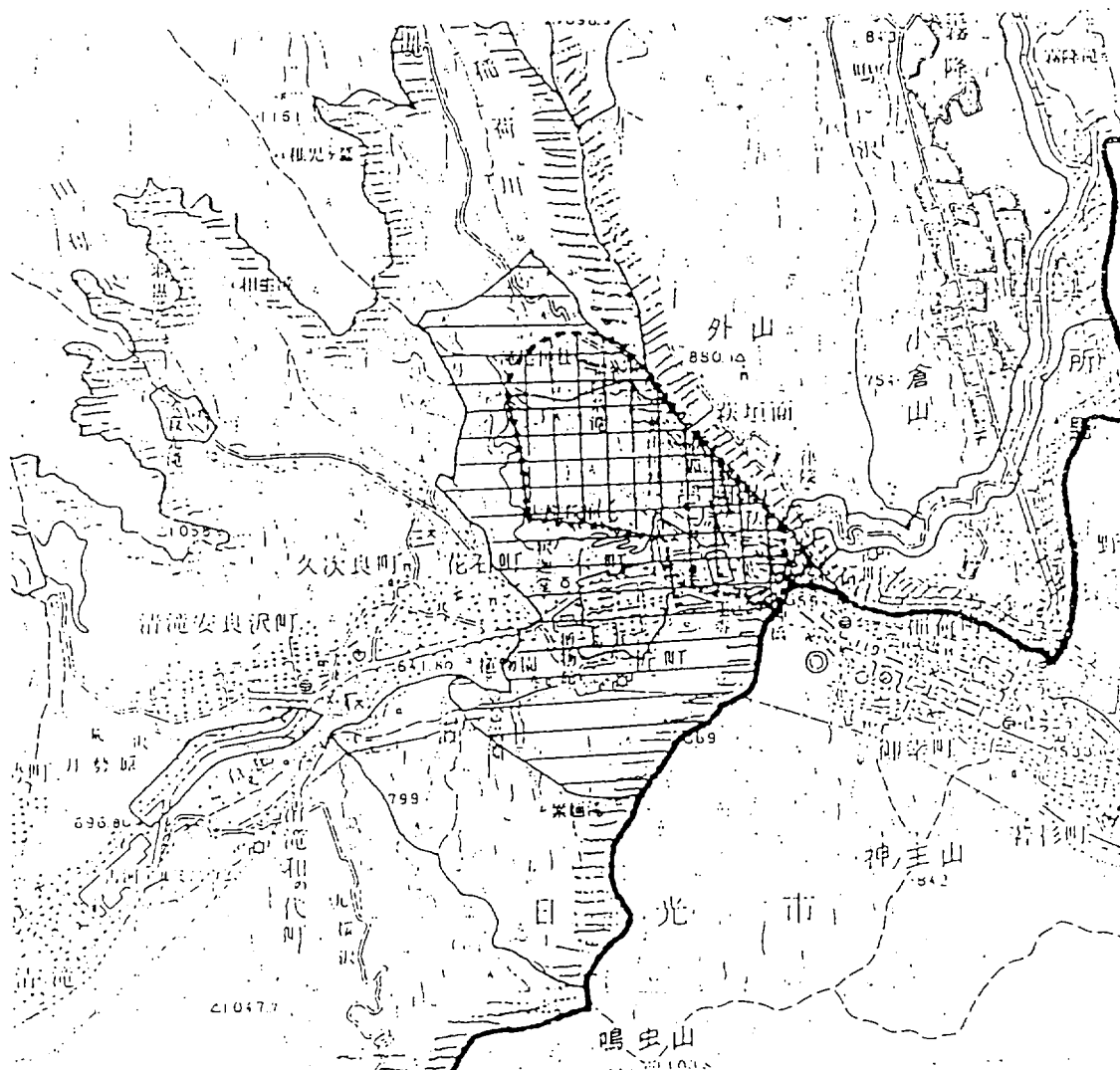

Sannai area



District of special significance for the historical landscape

## Nikko (Japan)

No 913

### Identification

*Nomination* Shrines and Temples of Nikko

*Location* Tochigi Prefecture

*State Party* Japan

*Date* 30 June 1998

### Justification by State Party

Each building included in the nominated property represents outstanding artistic value as a masterpiece created by some of the earliest architectural geniuses in Japan. **Criterion i**

The two mausoleums included in the nominated property - Tōshōgū and the Taiyū-in Reibyō - embody complete forms of the architectural style known as Gonzen-zukuri, the most advanced style of religious architecture in Japan at that time. Indeed, this style had great influence upon the architects of shrine buildings and mausolea in succeeding generations. The buildings vividly illustrate the collective ingenuity and creativity of the architects involved in the production of this architectural landscape; the extent of decoration introduced here had never been thus far in the history of Japan and buildings were arranged and coloured deliberately and effectively to produce an impression of integration. At the same time, they best represent the Japanese architectural style of Shinto shrines and Buddhist temples in the Edo period, the style characterized by mausolea. In particular, the buildings of Tōshōgū are an important, eloquent source of abundant information on this early architectural style used in Japan. The nominated property illustrates a significant stage in the history of architecture in Japan. **Criterion iv**

At the same time, the nominated property, including the surrounding setting as well as the group of religious buildings, is a typical example of traditionally observed religious space in Japan, directly associated with Shintoist attitudes toward nature, ie the Japanese indigenous religious belief, in which specific mountains or forests are deified as subjects of reverence.

In addition, Nikko is still an active religious place where rituals and other traditional events are so frequently held as to be a living tradition rooted in the daily lives of people at their spiritual level. **Criterion vi**

### Category of Property

In terms of the categories of cultural property set out in Article 1 of the World Heritage Convention, the Nikko shrines and temples are a *group* of buildings in a natural setting laid out by man to form a *site*, with the value of a *cultural and associative landscape*, as described in paragraph 39 of the *Operational Guidelines for the Implementation of the World Heritage Convention* (1998).

### History and Description

#### History

The cultural property proposed for inscription is linked to a cult that goes back to the end of the 8th century, when a Buddhist monk, Shodo, erected the first buildings on the slopes of the Nikko, which had been worshipped as a sacred mountain since time immemorial. Certain buildings in the Futarasan-jinja and Rinnō-ji groups belong to this period.

At the end of the 12th century, the Kamakura Shogunate established itself in the region of Kanto. This enabled Nikko to strengthen its position further as a major sacred site in Kanto, not only because of its mountainous situation but also because of its religious edifices. However, the site was more or less abandoned owing to the upheavals of the Muromachi period, in the 16th century.

The temples were rehabilitated at the beginning of the 17th century. Nikko was chosen as the site for the Tōshōgū, a sanctuary composed of several buildings erected to house the mausoleum of Tokugawa Ieyasu, the founder of the Tokugawa Shogunate. This regime was in power for over 250 years in the history of Japan. Since this period, Nikko has played a very important role as a symbol of national sovereignty, not only in the eyes of local authorities but also those of leaders of neighbouring countries who sent their emissaries to pay tribute to Ieyasu, a deified personage.

In 1871, the Meiji government decided to divide the site and its religious buildings, which came under one religious authority, into three groups entrusted to three separate religious organizations: Futarasan-jinja and Tōshōgū for the Shinto cult, and Rinnō-ji for Buddhism. This reorganization entailed moving and restoring certain buildings. The sacred and prestigious character of the site made it possible to guarantee the preservation of Nikko which was placed under legal protection as of 1897, a measure subsequently reinforced on several occasions.

#### Description

- The Futarasan-jinja

Devoted to the three divinities of Mount Nantai, it forms a complex of buildings, 23 of which are listed as Important Cultural Properties under the Law Protecting Cultural Properties. Most of them were restored or built in the 17th century, following old traditions, and they exerted a general influence in the layout of shrines throughout Japan.

Among the most remarkable buildings, mention should be made of the Honden and the Haiden, the heart of the shrine, the Betsugū Takino-o-jinja Honden, with a construction plan dating back to the year 825, and the Shin-yosha, the oldest example of an architectural style which was to inspire the first construction phases of the Tōshōgū.

The Shinkyô is also part of the Futarasan-jinja. This sacred bridge, straddling the river Daiya, appears to belong to the Muromachi period. Its present configuration, a vermilion lacquer bridge resting on massive stone pillars, goes back to 1636. The roadway of the Shinkyô was swept away by a disastrous flood in 1902, but it was faithfully restored in 1904 and is undergoing major restoration work which is expected to finish in the year 2001.

- The Tôshôgu

This shrine, founded in the first half of the 17th century, comprises a large number of buildings, including 37 which are listed as Important Cultural Properties, the others being listed as National Treasures.

A suite of three sacred chambers is a perfect illustration of the H-shaped architectural layout known as Gongenzukuri, in which the Honden, the principal chamber, is linked to the Haiden, the oratory, by a stone-paved corridor called the Ishinoma.

The Shômen Karamon and the Haimen Karamon, a masterpiece of craftsmanship and decoration, is inspired by a foreign style, hence the common name of "Chinese door."

The Yômeimon, erected in 1636, is probably the most well known example of the architectural style of Nikko. It is covered in a profusion and infinite variety of decoration.

The Tôzai Sukibe, also dating to 1636, is a wall about 160m long, surrounding the Honden, Ishinoma, and Haiden group.

The Tôzai Kairo, a corridor 220m long, with a southern section formed of 25 sculpted panels, surrounds three sides of the same Honden, Ishinoma, and Haiden group.

- The Rinnô-ji

The origin of this Buddhist temple goes back to the 8th century, and it has always remained a place of worship. Major constructions were added at the beginning of the Edo period, especially in 1653 for the mausoleum of the third shogun, Tokugawa Iemitsu. It is composed of many buildings, including 37 listed as Important Cultural Properties.

The group, in the Gongenzukuri shape and style and composed of the Taiyû-in Reibyô Honden, Ainoma, and Haiden, is listed as a National Treasure. It is a pure masterpiece of architecture and decoration.

- The site

Thanks to centuries of landscaping, the temples and shrines blend harmoniously in their natural setting. The buildings are arranged on the mountain slopes in such a way as to create different visual effects. The perception of the views and scale of the edifices is conditioned by the carefully studied proportion of the stairs, the supporting walls, and the walls enclosing the area. The result is a striking impression of harmony and contemplation.

Thousands of Japanese cedars were planted during the Tôshôgu construction period in the early 17th century. They are at present at the peak of their growth. This cryptomeria forest provides an exceptional natural bower for the shrines and temples, adding considerably to the beauty and sacred character of the site.

## Management and protection

### *Legal status*

The buildings inscribed as National Treasures (9) or as Important Cultural Properties (94) by virtue of Article 27 of the Convention on the Protection of Cultural Heritage come under legal protection as well as strict management and conservation measures.

In view of its value as natural heritage, the entire site falls under different protection systems. Some of them were introduced a long time ago, as far back as the 17th century through statutory measures, and before that time through customary arrangements. Special schemes cover the various areas, sometimes in a concomitant manner. In addition to the 1950 Law on the Protection of Cultural Properties, which protects both the buildings and the area around them, mention should also be made of the Law on Forests, the Law on Rivers, the Law on Sand Control, the 1957 Law on Natural Parks (which identifies four categories with their own level of protection), as well as the different municipal directives on the specially assigned areas. Together, they form a comprehensive set of protective measures, and serve as the foundation for a carefully developed management plan.

### *Management*

The perimeter round the site proposed for inscription on the World Heritage List corresponds to the boundaries of the property owned by the monks in charge of its daily management. It is controlled by special regulations which, depending on the specific areas, are combined with the different protective measures mentioned above. The perimeter has an irregular shape, mainly due to the narrow excrescence in the south-east, near the sacred bridge (Shinkyô). A tiny separate plot of land, on which a very old religious building stands, has also been added to the perimeter. The reasoning behind the definition of the perimeter is based on the religious character of the site as well as a concern for clarity in the everyday management tasks carried out by the religious authorities.

The buffer zone also contains several areas which come under specific protection plans. Its demarcation follows the ridges of the hills surrounding the historic site, except in the south-west, where it follows the boundaries of cadastral plots of land and areas protected by the Law on Natural Parks.

The preservation of the entire site, including the buffer zone, is subject to a precise definition of responsibilities, from the religious authorities in charge of the everyday management and regular maintenance of the site to the National Bureau of Cultural Affairs responsible for the general supervision and financing of the most expensive operations, based on a plan covering several years. At intermediate levels, special responsibilities are carried out by the Nikko City Council in the areas of town planning, traffic and control of the buffer zone, and by the Tochigi Prefecture in the areas of education and public awareness, particularly the handling of tourists.

A large number of visitors frequent the shrines and temples of Nikko. In 1996, out of a total of about 1.7 million visitors, 550,000 were students on educational trips and 20,000 were foreign tourists. Strict measures are being applied, especially with regard to the parking of cars and coaches. Given the large crowds on national public holidays or at the beginning of autumn, the religious

authorities take action to control the flow of visitors; these measures can even go as far as fixing quotas in order to preserve not only the physical integrity of the buildings and the natural site but also the sacred character of the place.

## **Conservation and Authenticity**

### *Conservation History*

The conservation of the Nikko shrines and temples is the outcome of a respect for age-old traditions of conservation and restoration as well as the preservation of religious practices linked to a site considered as sacred.

A methodical approach was adopted at a very early stage. A remarkable manuscript written in 1753 contains many comments on the works undertaken during the 17th century, which the monks concerned recorded in writing. The very precise descriptions of the architectural structures and the decorative works contained in this manuscript make it a very precious reference work, which is frequently consulted even now. The manuscript, for example, sets out the traditional directions for the use of colours, with accurate references to the pigments and their place of origin.

This practice of keeping meticulous records has been respected up to the present time.

The Decree of 1871 relating to the separation of the Shinto and Buddhist cults was adopted under the Meiji Restoration. In Nikko, two Shinto shrines and a Buddhist temple were entrusted to three distinct religious organizations. Within this framework, a few buildings, fortunately few in number, were demolished, transformed, or moved elsewhere. These breaches to the integrity of the historic site came to an end with the setting up in 1879 of the Association for the Conservation of the Shrines and Temples of Nikko, called Hokokai, which is still active today, and by the adoption in 1897 of a Law on the Preservation of Shrines and Temples.

### *Authenticity*

There is no doubt that this historic site has suffered from difficulties over the centuries. Buildings were burnt down or damaged by falling trees or earthquakes. Each time, the damaged building was restored faithfully, following rigorously the original plans and techniques, using the original materials whenever possible, and keeping detailed documents about these operations.

This fidelity to the initial model and the significance of the religious buildings reveals a determination to respect their authenticity. In general, the management of the site aims at preserving the rich harmony of the cultural landscape which unites natural features and buildings.

### *Risk prevention*

Right from the start, preventive measures and emergency plans were adopted to cope with the dangers of fires and earthquakes. This has always been a constant preoccupation. In the course of this century, in particular, every new prevention technique has been adopted immediately. Thus, a sophisticated system of water jets, fed by huge underground reservoirs, was installed in the fifties. The latest teledetection techniques have been incorporated unobtrusively to monitor any sign of possible danger from a central observatory.

The forest of cryptomeria is also controlled regularly and the trees are strengthened to prevent them from falling over the buildings.

### *Training*

General maintenance and restoration projects are looked upon as a "school of application" enabling artists and craftsmen to teach themselves. High-level proficiency courses are organized in Nikko, in the form of residential seminars lasting several months, for about fifteen craftsmen selected from all over the country. The most frequently practised specializations are the ones using decorative techniques (colours, lacquers, and varnishes) which have received the highest degree of application in Nikko. These training programmes are supervised by Master Hokusai Yoshihara, one of the two most famous artists in this discipline who are recognized as Living Cultural Treasures.

## **Evaluation**

### *Action by ICOMOS*

An ICOMOS expert commission visited Nikko in December 1998.

### *Qualities*

The Nikko shrines and temples form a group of religious buildings, in an outstanding natural setting, testifying to a centuries-old tradition. It has been a sacred place for centuries, and it still continues to be a centre of religious practice. The site also evokes the glorious chapters of Japanese history, especially those relating to the symbolic figure of the great Shogun, Tokugawa Ieyasu.

### *Comparative analysis*

The unusual character of the Nikko shrines and temples is due to a combination of very strong values: a long tradition of worship, a very high level of artistic achievement, a striking alliance between architecture and the development of a natural setting, and a repository of national memories. Other sites can reflect one or another of these values, but it is this particular combination which makes Nikko such an outstanding cultural property.

### *ICOMOS recommendations for future action*

- Despite protective measures and a management system of the historic site which are exemplary in many respects, three suggestions can be put forward:
- With respect to Tōshōgu, the documents supporting the request for inscription should fill in the lack of information on two buildings: on the one hand, the Kyozo, with its revolving library containing thousands of volumes of sutras, some of which date back to the early 17th century, and on the other, the Honkido, well known for its Weeping Dragon, a remarkable ceiling painting. These two buildings come under the responsibility of the Association for the Conservation of the Shrines and Temples of Nikko.
- Signs should be improved so as to be in line with the cultural importance of the site. The signs should be made in more unobtrusive materials and have clearer graphics for the directions (in one or more foreign languages) and the information panels should be better positioned. The provisions of the Management

Plan for the Nikko National Park, adopted in 1996, point the way.

- Controlling the buffer zone requires special attention for two reasons. First, the south-west border does not follow the ridge-line and crosses an area which could give in to pressure from real-estate promoters. Secondly, the capacity to handle the growing numbers of visitors will continue to be a permanent challenge.

### **Brief Description**

The Nikko shrines and temples, together with their natural surroundings, have for centuries been a sacred site and the home of architectural and decorative masterpieces. They are closely associated with the history of the Tokugawa Shoguns.

### **Recommendation**

That this property be inscribed on the World Heritage List on the basis of *criteria i, iv, and vi*:



*Criterion i* The Nikko shrines and temples are a reflection of architectural and artistic genius; this aspect is reinforced by the harmonious integration of the buildings in a forest and a natural site laid out by man.

*Criterion iv* Nikko is a perfect illustration of the architectural style of the Edo period as applied to Shinto shrines and Buddhist temples. The Gongenzukuri style of the two mausoleums, the Tōshōgū and the Taiyū-in Reibyō, reached the peak of its expression in Nikko, and was later to exert a decisive influence. The ingenuity and creativity of its architects and decorators are revealed in an outstanding and distinguished manner.





*Criterion vi* The Nikko shrines and temples, together with their environment, are an outstanding example of a traditional Japanese religious centre, associated with the Shinto perception of the relationship of man with nature, in which mountains and forests have a sacred meaning and are objects of veneration, in a religious practice that is still very much alive today.

ICOMOS, September 1999

MAP INDICATING THE NOMINATED PROPERTY AND THE SURROUNDING NATURAL AND BUILT ENVIRONMENT

	Nominated property	50.8ha
	Buffer zone*	373.2ha
	(Total)	424.0ha)

\*not including the nominated property

- 1 Group of buildings
-  A Futarasan-jinja
  -  B Tōshōgū
  -  C Rinnō-ji
- 2 Site (cultural landscape) 

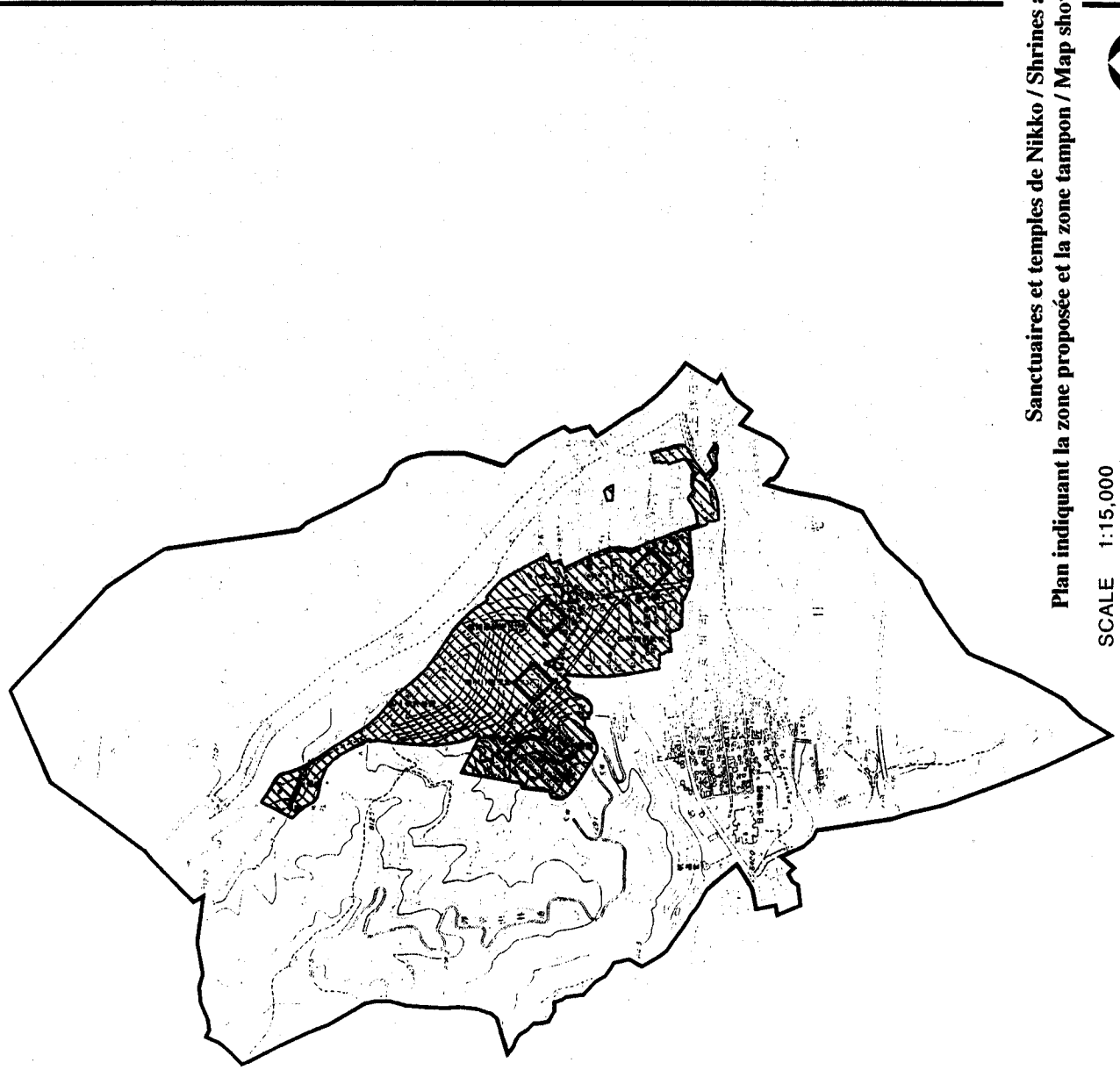

Sanctuaires et temples de Nikko / Shrines and Temples of Nikko :  
 Plan indiquant la zone proposée et la zone tampon / Map showing nominated property and buffer zone

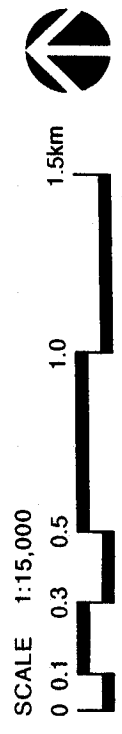

## Nikko (Japon)

No 913

### Identification

<i>Bien proposé</i>	Sanctuaires et temples de Nikko
<i>Lieu</i>	Préfecture de Tochigi
<i>Etat Partie</i>	Japon
<i>Date</i>	30 juin 1998

### Justification émanant de l'Etat Partie

Les sanctuaires et temples de Nikko ont une valeur artistique exceptionnelle et représentent autant de chef d'œuvres dus au génie des premiers architectes japonais.

#### Critère i

Les deux mausolées inclus dans la proposition d'inscription – le Tōshōgū et le Taiyū-in Reibyō – sont une illustration parfaite du style architectural connu comme "Gongen-zukuri", forme la plus aboutie de l'architecture religieuse de l'époque. Ce style devait exercer une grande influence sur les bâtisseurs de sanctuaires et de mausolées des générations suivantes. Ces édifices démontrent l'ingéniosité et la créativité des architectes qui ont réalisé ce paysage architectural ; la décoration exubérante introduite ici était inconnue jusque là dans l'histoire du Japon et les édifices étaient disposés et colorés à dessein et avec efficacité pour s'intégrer parfaitement dans le paysage. Ils offrent aussi une parfaite représentation du style architectural de la période Edo appliqué aux sanctuaires shintoïstes et aux temples bouddhistes, style qui se caractérise par ses mausolées. Les bâtiments du Tōshōgū en particulier constituent une source d'information importante et éloquente sur cet ancien style architectural japonais. Le bien proposé pour inscription illustre une étape significative de l'histoire de l'architecture au Japon.

#### Critère iv

Les édifices religieux et leur environnement qui composent cette proposition d'inscription constituent un exemple typique d'espace religieux traditionnel japonais, directement associé à la perception shintoïste des rapports avec la nature, où les montagnes et les forêts ont une charge religieuse et sont objets de vénération.

Nikko est d'ailleurs un lieu de culte toujours en activité, où se déroulent souvent des manifestations traditionnelles bien vivantes dans l'esprit et la vie quotidienne du peuple.

#### Critère vi

### Catégorie de bien

En termes de catégories de biens culturels, telles qu'elles sont définies à l'article premier de la Convention du patrimoine mondial de 1972, les sanctuaires et temples de Nikko constituent un *ensemble* qui s'inscrit dans un cadre naturel aménagé par l'homme pour former un *site* ayant valeur de *paysage culturel associatif* comme décrit au paragraphe 39 des *Orientations devant guider la mise en œuvre de la Convention du patrimoine mondial* (1998).

### Histoire et description

#### Histoire

Le bien culturel proposé à l'inscription a une destination liée au culte qui remonte à la fin du VIII<sup>e</sup> siècle, quand un moine bouddhiste, Shōdō, érigea les premiers édifices au flanc de la montagne de Nikko, laquelle était vénérée comme montagne sacrée depuis les temps les plus anciens. Certains édifices des deux ensembles Futarasan-jinja et Rinnō-ji remontent à cette période.

A la fin du XII<sup>e</sup> siècle, le shogunat Kamakura s'établit dans la région du Kanto. Nikko s'affirma davantage encore, tant par son site montagneux que par les édifices religieux, comme un lieu sacré majeur du Kanto. Mais les troubles de la période Muromachi, au XVI<sup>e</sup> siècle, entraînèrent un relatif délaissement du site.

Au début du XVII<sup>e</sup> siècle, il fut procédé à une réhabilitation des temples. Nikko fut choisi comme site pour la construction du Tōshōgū, un sanctuaire avec plusieurs édifices destiné à accueillir le mausolée de Tokugawa Ieyasu, le fondateur du shogunat Tokugawa. Ce régime devait exercer le pouvoir durant plus de 250 ans de l'histoire japonaise. Depuis cette époque, Nikko a rempli un rôle politique très important en symbolisant la souveraineté nationale, aussi bien aux yeux des autorités locales qu'à l'égard des dirigeants des pays voisins, dont les émissaires venaient rendre hommage à Ieyasu, personnage déifié.

En 1871, le gouvernement Meiji décida de répartir le site et les édifices religieux qui relevaient d'une seule entité religieuse, en trois ensembles, confiés à trois organisations religieuses distinctes : Futarasan-jinja et Tōshōgū au culte shintoïste, et Rinnō-ji au culte bouddhiste. Cette réorganisation entraîna le déplacement et la restauration de certains édifices. Le caractère sacré et prestigieux du site permit de garantir la sauvegarde de Nikko qui, dès 1897, fut placé sous une protection légale renforcée ensuite à plusieurs reprises.

#### Description

- Le Futarasan-jinja

Consacré à trois divinités du mont Nantai, il forme un ensemble d'édifices dont 23 sont inscrits comme "Biens culturels importants" selon la Loi de protection

des biens culturels. La plupart ont été restaurés ou construits au XVIIIe siècle, selon les traditions anciennes, exerçant une influence générale à travers le Japon dans l'aménagement des sanctuaires.

Parmi les édifices les plus remarquables, il faut citer le Honden et le Haiden, coeur du sanctuaire, le Bestugû Takino-o-jinja Honden, dont le plan de construction remonterait à l'an 825, et le Shin-yosha, le plus ancien témoignage du style architectural qui allait inspirer les premières phases de construction du Tôshôgû.

Le Sinkyô relève aussi du Futarasan-jinja. Ce pont sacré enjambe la rivière Daiya et daterait de la période Muromachi. C'est en 1636 qu'il a reçu sa configuration actuelle : un pont de bois laqué au vermillon, reposant sur des piliers de pierre massifs. Le tablier du Sinkyô a été emporté par une inondation catastrophique, en 1902 ; il a été restauré à l'identique en 1904 et fait l'objet d'une restauration importante dont le terme est prévu en l'an 2001.

- Le Tôshôgû

Ce sanctuaire, fondé dans la première moitié du XVIIIe siècle, comporte un grand nombre d'édifices, dont 37 sont inscrits comme "Biens culturels importants", tandis que les édifices suivants sont inscrits comme "Trésors nationaux".

Un ensemble de trois chambres sacrées illustre parfaitement le dispositif architectural en forme de H dénommé "Gongen-zukuri" dans lequel le Honden, chambre principale, est reliée au Haiden, oratoire, par un corridor pavé de pierres, appelé Ishinoma.

Le Shômen Karamon et le Haimen Karamon, chef d'œuvre d'artisanat et de décoration, inspiré d'un style étranger qui lui a donné le nom courant de "porte chinoise".

Le Yômeimon, érigé en 1636, probablement l'œuvre architecturale la plus connue de Nikko, est un édifice chargé d'une décoration d'une infinie variété.

Le Tôzai Sukibê est un mur de quelque 160m, datant aussi de 1636, qui entoure l'ensemble Honden, Ishinoma et Haiden.

Le Tôzai Kairô, corridor de 220m, dont la partie sud est formée de 25 panneaux sculptés, entoure sur trois côtés le même ensemble Honden, Ishinoma et Haiden.

- Le Rinnô-ji

Ce temple bouddhiste, dont les origines remontent au VIIIe siècle, est resté en permanence un lieu de culte. Des constructions importantes ont été ajoutées au début de la période Edo, notamment en 1653, pour aménager le mausolée du troisième shogun Togukawa Iemitsu. Il comporte de nombreux édifices, dont 37 sont inscrits comme "Biens culturels importants"

L'ensemble de forme et de style "Gongen-zukuri" formé par le Taiyû-in Reibyô Honden, Ainoma et Haiden est inscrit comme "Trésor national". Il

constitue un pur chef d'œuvre d'architecture et de décoration.

- Le site

Un aménagement paysager séculaire a produit une insertion remarquable des temples et sanctuaires dans le cadre naturel. Au flanc des pentes montagneuses, les édifices sont disposés de manière à ménager divers effets visuels. La perception des perspectives et de l'échelle des constructions est conditionnée par les proportions étudiées des escaliers, des murs de soutènement et des parois qui cloisonnent l'espace. Il s'en dégage une impression saisissante d'harmonie et de recueillement.

Au moment de l'aménagement du Tôshôgû, au début du XVIIIe siècle, des milliers de cèdres ont été plantés. Ils ont aujourd'hui atteint leur plein développement. Cette forêt de cryptomeria offre un écrin naturel extraordinaire pour les sanctuaires et les temples, contribuant, de manière déterminante, à la beauté et au caractère sacré du site.

## Gestion et protection

### *Statut juridique*

Les édifices inscrits comme "Trésors nationaux" (9) ou comme "Biens culturels importants" (94) en vertu de l'article 27 de la Loi de protection des biens culturels font l'objet d'une protection juridique et de mesures de gestion et de conservation strictes

L'ensemble du site, en particulier dans ses valeurs de patrimoine naturel, comporte diverses zones de protection. Certaines sont fixées depuis très longtemps : depuis le XVIIIe siècle, dans des mesures réglementaires et, antérieurement, dans des dispositions coutumières. Des régimes spécialisés couvrent ces diverses zones, parfois de manière concomitante : outre la Loi de protection des biens culturels de 1950, qui protège à la fois les édifices et le périmètre dans lequel ils sont situés, il convient de mentionner la Loi sur les forêts, la Loi sur les rivières, la Loi sur le contrôle des sables, la Loi sur les parcs naturels de 1957 (laquelle distingue 4 catégories avec un niveau de protection spécifique), ainsi que diverses prescriptions municipales qui portent sur des zones d'affectation spéciale. Le tout forme un arsenal de mesures de protection complet, fondement d'un plan de gestion très élaboré.

### *Gestion*

Le périmètre du site proposé à l'inscription sur la Liste du Patrimoine mondial correspond aux limites des propriétés foncières des moines en charge de la gestion journalière. Il fait l'objet d'une réglementation particulière, qui se combine, suivant les zones, avec les diverses mesures de protection mentionnées plus haut. Sa forme est irrégulière, notamment par l'excroissance étroite du sud-est autour du pont sacré (Skinkyô). Un minuscule terrain séparé sur lequel s'élève un très ancien édifice religieux est ajouté au périmètre. La logique de définition du périmètre



relève du caractère religieux du site ainsi que du souci de clarté dans les responsabilités de gestion courante, précisément assumées par les autorités religieuses.

La zone tampon, elle aussi, comprend diverses aires relevant de plans de protection spécifiques. Sa délimitation suit les lignes de crête des collines entourant le site historique, sauf au sud-ouest, où elle suit les limites de parcelles cadastrales et de zones protégées par la Loi sur les parcs naturels.

La sauvegarde de l'ensemble du site et de la zone tampon fait l'objet d'une définition précise des responsabilités, depuis les autorités religieuses, chargées de la gestion courante et de l'entretien régulier, jusqu'au Bureau national des affaires culturelles qui assure une supervision générale et le financement des opérations les plus onéreuses selon une planification pluriannuelle. Aux niveaux intermédiaires, des responsabilités particulières sont assumées par la Municipalité de Nikko, en matière d'urbanisme, de circulation et de contrôle sur la zone tampon, et par la Préfecture de Tochigi, en matière d'éducation et de sensibilisation du public, avec notamment le contrôle des flux touristiques.

De nombreux visiteurs fréquentent les sanctuaires et temples de Nikko. En 1996, sur un total de quelque 1,7 millions de visiteurs, 550.000 étaient des étudiants en voyage scolaire et 20.000 des visiteurs étrangers. Des mesures strictes sont d'application, notamment pour le stationnement des voitures et des autocars. Compte tenu de la grande affluence enregistrée lors de jours fériés nationaux ou au début de l'automne, les autorités religieuses prennent des mesures d'encadrement des visiteurs qui peuvent aller jusqu'au contingentement, dans le souci de préserver non seulement l'intégrité physique des édifices et du site naturel, mais aussi le caractère sacré des lieux.

## **Conservation et authenticité**

### *Historique de la conservation*

La conservation des sanctuaires et temples de Nikko s'inscrit dans un contexte de respect des traditions séculaires de conservation et de restauration ainsi que de maintien des pratiques religieuses liées à un site considéré comme sacré.

Très tôt, une approche méthodique est adoptée. C'est ainsi qu'un remarquable manuscrit, daté de 1753, contient de nombreux commentaires sur les travaux du XVII<sup>e</sup> siècle que les moines ont consignés par écrit. Des indications très précises y sont données, en rapport avec les structures architecturales et les travaux de décoration, pour former un document de référence très précieux régulièrement consulté de nos jours. Ce manuscrit indique, par exemple, les prescriptions traditionnelles pour les couleurs, avec références précises sur les pigments et leur lieu de provenance.

Cette pratique de tenue minutieuse des archives a été respectée jusqu'à nos jours.

Sous la Restauration Meiji fut adopté le Décret de 1871 relatif à séparation des cultes shintoïste et bouddhiste. A Nikko, deux sanctuaires shintoïstes et un temple bouddhiste furent confiés à trois organisations religieuses distinctes. Dans ce cadre, quelques édifices, en nombre heureusement limité, furent supprimés, transformés ou déplacés. Un terme fut mis à ces atteintes à l'intégrité du site historique par la constitution, en 1879, d'une "Association pour la conservation des sanctuaires et des temples de Nikko", appelée Hokokai, encore active aujourd'hui et par l'adoption, en 1897, d'une Loi pour la préservation des sanctuaires et des temples.

### *Authenticité*

Au cours des siècles, le site historique a certes connu bien des vicissitudes. Des édifices ont été incendiés ou endommagés par des chutes d'arbre ou des tremblements de terre. Chaque fois, il a été procédé à une restauration à l'identique, dans le respect strict des plans et des techniques d'origine, en utilisant le plus possible les matériaux d'origine et en gardant une documentation détaillée sur ces opérations.

Cette fidélité au modèle initial et à la signification même des édifices religieux témoignent d'une exigence véritable de respect de leur authenticité. De manière plus générale, la gestion du site vise à maintenir dans toute sa richesse l'harmonie du paysage culturel qui allie les éléments naturels et les édifices construits.

### *Prévention des risques*

Depuis les origines, des mesures préventives et des plans d'intervention d'urgence ont été adoptés pour faire face aux dangers d'incendie ou de tremblement de terre. Cette préoccupation est restée constante. Au cours de ce siècle, en particulier, toute nouvelle technique de prévention a rapidement été adoptée. Ainsi, un système perfectionné de jets d'eau, alimentés par de vastes citernes souterraines, a été installé dans les années cinquante. Les techniques les plus récentes de télédétection, intégrées avec grande discrétion, permettent de contrôler, depuis un observatoire central, tout signe suspect.

La forêt de cryptomeria fait aussi l'objet d'examen de contrôle régulier et de mesures de consolidation des arbres pour prévenir leur chute sur les édifices.

### *Formation*

La maintenance générale et les travaux de restauration sont considérés comme une "école d'application" permettant à des artistes et à des artisans de se former. Des cours de perfectionnement de haut niveau sont organisés à Nikko, sous forme de séminaires résidentiels de plusieurs mois, accueillant une quinzaine d'artisans sélectionnés à travers tout le pays. Les spécialités les plus pratiquées portent sur les techniques de décoration qui ont reçu à Nikko le plus haut degré d'application : couleurs, laques, vernis. Ces programmes de formation sont placés sous la haute supervision du Maître Hokusai Yoshihara, un des deux artistes reconnus, dans cette discipline, comme "Trésors culturels vivants".

## Evaluation

### *Action de l'ICOMOS*

Une mission d'expertise de l'ICOMOS a visité Nikko en décembre 1998.

### *Caractéristiques*

Les sanctuaires et temples de Nikko forment un ensemble d'édifices religieux, témoins d'une tradition séculaire, dans un cadre naturel exceptionnel. Depuis des siècles, il constitue un lieu sacré et, aujourd'hui encore, connaît une pratique religieuse régulière. Le site évoque aussi des heures glorieuses de l'histoire du Japon, en particulier autour de la figure emblématique du grand shogun Tokugawa Ieyasu.

### *Analyse comparative*

Le caractère singulier des sanctuaires et temples de Nikko tient à la conjonction de valeurs très fortes : une longue tradition culturelle, un très haut niveau de réalisation artistique, une alliance saisissante entre l'architecture et l'aménagement du cadre naturel, un lieu de mémoire national. D'autres sites peuvent refléter telle ou telle de ces valeurs, mais cette conjonction fait de Nikko un "bien culturel" exceptionnel.

### *Recommandations de l'ICOMOS pour des actions futures*

Malgré une protection et une gestion du site historique à bien des égards exemplaires, trois suggestions sont à formuler :

Concernant le Tōshōgū, la documentation présentée à l'appui de la demande d'inscription devrait combler l'absence d'informations relatives à deux édifices : d'une part, le Kyōzō, avec sa bibliothèque tournante comprenant des milliers de volumes de soutras, dont certains datent du début du XVII<sup>e</sup> siècle ; d'autre part, le Honkidō, bien connu pour son "Dragon pleureur", dessin remarquable peint au plafond. Ces deux édifices sont placés sous la garde de l'Association pour la conservation des sanctuaires et temples de Nikko.

La signalisation mérite des soins plus attentifs pour être à la hauteur de l'importance culturelle du site. Cela, tant dans le choix de matériaux plus discrets que dans le graphisme des indications, l'emploi de l'une ou l'autre langue étrangère et la localisation des panneaux d'information. Les prescriptions du "Plan de gestion du Parc National de Nikko" adopté en 1996 indiquent la voie à suivre.

Le contrôle de la zone tampon demande une attention particulière : d'une part, la limite sud-ouest ne suit pas une ligne de crête et traverse une zone susceptible de connaître des pressions immobilières ; d'autre part, la maîtrise des flux croissants de visiteurs restera un défi permanent.

## Brève description

Les sanctuaires et temples de Nikko et le cadre naturel qui les entoure constituent, depuis des siècles, un lieu sacré où se sont élevés des chefs d'œuvre d'architecture et de décoration artistique. Ils sont étroitement liés à la mémoire des shoguns Tokugawa.

## Recommandation

Que ce bien soit inscrit sur la Liste du patrimoine mondial sur base des *critères i, iv et vi* :



**Critère i** : les sanctuaires et temples de Nikko portent la marque du génie architectural et artistique ; ce caractère est renforcé par la parfaite intégration des édifices dans une forêt et un site naturel aménagés par l'homme.

**Critère iv** : Nikko offre une parfaite représentation du style architectural de la période Edo appliqué aux sanctuaires shintoïstes et aux temples bouddhistes. Le style "Gongen-zukuri" des deux mausolées, le Tōshōgū et le Taiyū-in Reibyō, connaît à Nikko son illustration la plus aboutie, qui allait exercer dans la suite une influence déterminante. L'ingéniosité et la créativité des architectes et des artistes décorateurs s'y révèlent d'une manière singulière et éminente.



**Critère vi** : les sanctuaires et temples de Nikko et leur environnement évoquent un espace religieux traditionnel japonais, associé à la perception shintoïste des rapports avec la nature, où les montagnes et les forêts ont une charge sacrée et sont objets de vénération, dans une pratique religieuse encore vivante aujourd'hui.

ICOMOS, septembre 1999

MAP INDICATING THE NOMINATED PROPERTY AND THE SURROUNDING NATURAL AND BUILT ENVIRONMENT

	Nominated property	50.8ha
	Buffer zone*	373.2ha
	(Total)	424.0ha)

\*not including the nominated property

- 1 Group of buildings
-  A Futarasan-jinja
  -  B Tôshôgû
  -  C Rinnô-ji
- 2 Site (cultural landscape) 

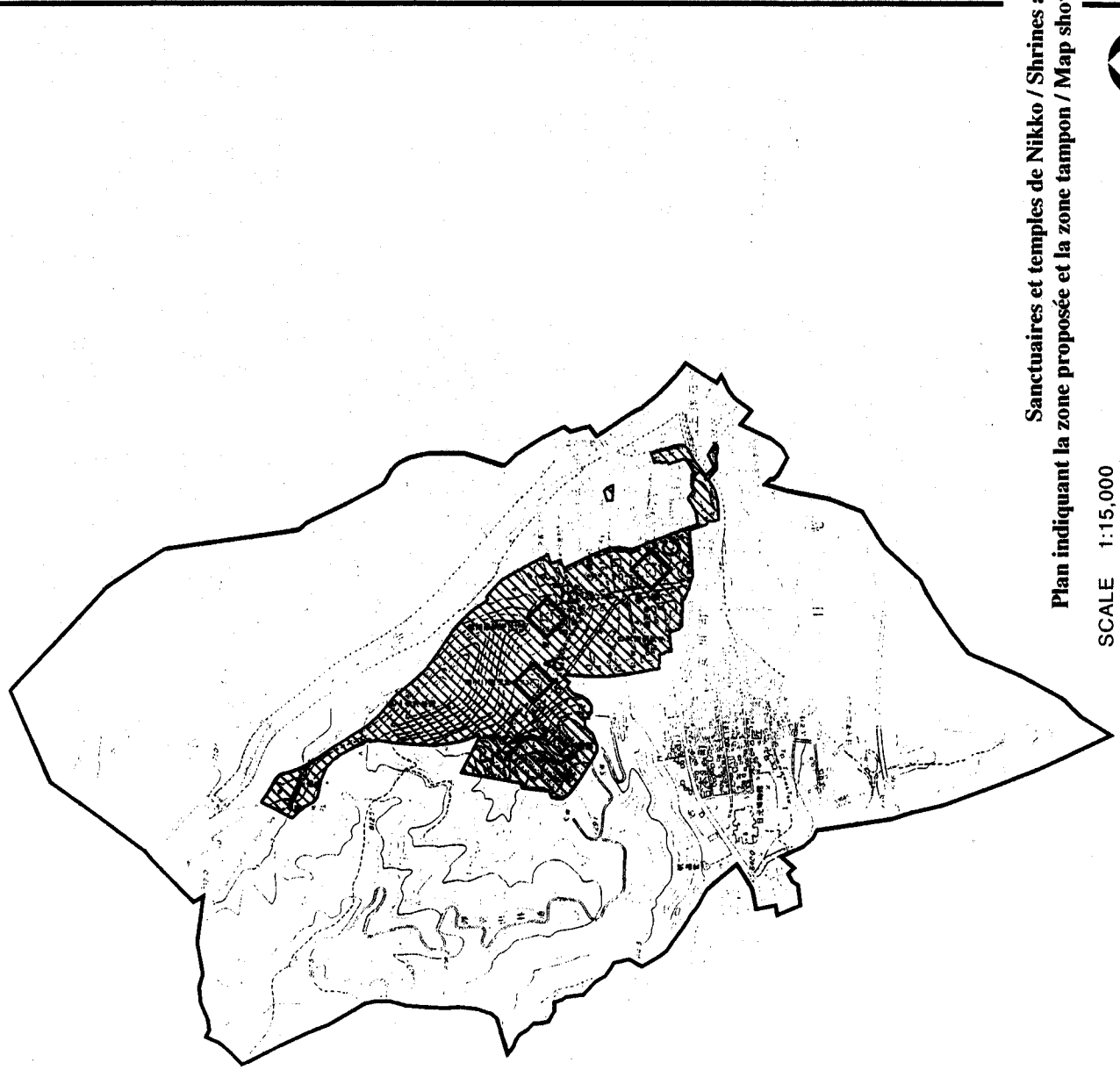

Sanctuaires et temples de Nikko / Shrines and Temples of Nikko :

Plan indiquant la zone proposée et la zone tampon / Map showing nominated property and buffer zone

