



# Guyana

Updated version, August 2006.

## Principles and general objectives of education

Education is considered a right for all and is accessible to all Guyanese children from the age of 3 years and 9 months to the age of 16, although education is compulsory up to the age of 14. Education is “one of the engines of growth and holistic development” and “one of the most important social mechanisms for the acculturation and socialization of the nation’s young people along lines that are desirable socially and economically” (Ministry of Education and Cultural Development, 1995, p. 7). Education also seeks to: prepare children for life in a rapidly changing social milieu, and in an environment that is envisioned as heavily influenced by scientific and technological developments; and inculcate in the young “knowledge, skills, discipline, values, adaptability and the capacity to think critically and act creatively in the interest of their personal growth and development as well as that of their society and nation” (*ibid.*, p. 10).

Education seeks to enable children to:

- acquire knowledge, skills and values necessary for a full and satisfying adult life;
- cherish love for their country;
- develop their potential to the fullest;
- cultivate tolerance and respect for cultural and religious differences among people;
- adhere to principles of democracy, justice, peace and accountability;
- develop a spirit of self-reliance and resilience;
- bring to bear creative and innovative approaches to problem solving;
- harbour a commitment to the care and protection of the environment;
- live productive lives in a rapidly changing technological age.

## Current educational priorities and concerns

Guyana’s economy depends heavily on sugar, rice and bauxite exports. The 1970s witnessed a prolonged and serious economic decline in the country which was triggered by a complex of factors, including the socialist policies of the government, state ownership of key sectors of the economy which in many instances resulted in poor management, an increase in oil prices world wide and a fall in the prices of key



exports. The flight of skilled professionals over more than two decades left the country depleted of the quality of human resources needed for its development.

During this period, ideological conflicts and racial tensions have exacerbated the situation. While animosities between the Guyanese of East Indian origin and those of African descent remain a cause for concern, increasing attention is being given to the nine Amerindian tribes (the original inhabitants of Guyana) who have been marginalized on the fringes of society. Constituting about 6% of the population, they live mainly in the hinterland regions of Guyana where educational provisions are limited and poor compared with the rest of the country.

Guyana's economic, social and political problems have had a marked effect on its education system at all levels. The low level of financing of education has contributed to a deterioration in the condition of all schools, many of which do not have running water, electricity, adequate and sanitary toilet facilities, or adequate supplies of teaching/learning resources. Only one quarter of the primary school textbook requirement is met (World Bank, 1993). Attendance levels are low. The attendance rate nationally is given at 68% with the level falling as low as 50% in certain regions (*ibid.*). High rates of teacher migration to other Caribbean territories where working conditions and salaries are better have left the secondary system poorly staffed with many untrained and unqualified teachers. The academic achievement of the children has suffered. The Caribbean Examinations Council Secondary Education Certificate (CXCSEC) examination is taken by less than 20% of the age cohort. Despite widespread private tuition (called extra lessons), in 1992 only about 10% of the students who sat English language passed, and 18% passed mathematics. Amongst sixteen Caribbean countries, Guyana's performance at the CXCSEC overall is the poorest. Critical areas of weakness in the secondary curriculum are English, mathematics and the sciences—especially physics.

The impact of this is also felt at the tertiary level, where the University of Guyana has difficulty recruiting students for the science- and mathematics-based disciplines (faculties of natural sciences and technology). The University has also suffered from the effects of the country's economic crisis. Inadequate financing and poor salaries have made it impossible to attract sufficient numbers of highly qualified staff, given that their earnings would be one-fifteenth of what they could earn in similar jobs in other parts of the Caribbean (Craig, 1993). Poor maintenance of the physical plant, lack of essential equipment and laboratories, inadequate classroom facilities and library materials have also for many years plagued the university.

The country began to stem its economic decline in the late 1980s. Diversification in the economy has led to dramatic increases in revenue from industries which have attracted foreign capital, for example, timber, gold and diamond mining. Increases in the country's annual growth rate, a drop in inflation have been spearheaded by stabilization and adjustment programmes with the International Monetary Fund and the World Bank. The new government that came to power in 1992 has capitalized on these gains and put more emphasis on the social sector. Despite this, the country's per capita income remains among the lowest of the countries in the Western hemisphere and it has one the largest national debts in the Caribbean region.



In an effort to improve the efficiency and effectiveness with which the Ministry of Education could deliver education outside Georgetown, the capital, in 1985 the management of the education system was decentralized by transferring to Regional Democratic Councils and their Regional Education Departments (REDs) some of the authority which had formerly resided in the Central Ministry. The country was divided into ten regions with a total of eleven REDs. This included Georgetown as a separate department, even though it is located in Region IV. The main objectives of decentralization are:

- to promote the involvement of communities in the management of education;
- to enable the Ministry of Education through the REDs to respond more rapidly to the needs of the community (Paul *et al.*, 1991).

With regard to the nursery level, 72 headteachers of nursery schools were trained between 1987 and 1990. A one-year part-time programme (1990-91) was organized for the training of field officers who were selected from the headteachers who had been trained. The field officers are responsible for supervising nursery schools and providing feedback to the Ministry of Education and the training college on all aspects of the nursery programme.

In 1991/92 the Faculty of Education at the University of Guyana introduced a Bachelor's degree programme specializing in nursery education. The programme offers different options depending on whether the candidate wishes to focus—administration, supervision or classroom teaching. The classroom teaching option is of five years duration on a part-time basis for secondary school graduates who meet the university's entrance requirements, while the other options are for four years (part-time) for trained teachers with at least two years of experience. The first cohort graduated in 1995.

The Primary Education Improvement Project (PEIP), funded by the Inter-American Development Bank, was introduced in 1990. Its overall objective is to improve the quality of primary education. To this end, it focuses on three major areas where significant deficiencies were found to be impeding the effectiveness of primary education: (a) professional qualification and skills training of teachers; (b) availability of textbooks and other curriculum materials; and (c) physical facilities in the school.

As part of its human resources development strategy, the PEIP has provided in-service training for teachers designed to give them basic pedagogical skills and increase their competence to use more effective teaching methods. The major part of the loan has been used to improve the physical conditions of primary schools, either through rehabilitation or through construction of new buildings. Teaching materials, equipment and furniture needed to support educational activities have also been provided.

Introduced in 1988 to stem the decline in performance at the CXCSEC, the National Fourth-Form Achievement Test (NFFAT) was taken by students at the end of Form IV in general secondary schools. The examination was designed to: (a) identify strengths and weaknesses in student performance; and (b) provide data to facilitate selection of subjects for the CXCSEC examination. The untimely setting of



examination papers, poor administration of the examination itself, inadequate funding and negative attitudes towards the examination have plagued NFFAT since its inception. The late publication of results also militated against the achievement of the second objective. However, research has shown that NFFAT is a reasonably good predictor of performance at the CXCSEC examination (Kellman *et al.*, 1995).

The primary objective of the Secondary School Reform Programme (SSRP) is to improve the quality, relevance, equity and efficiency of secondary education in Guyana. More specifically, the project seeks to: (i) develop measures to improve the quality and efficiency of lower secondary education and test them in a limited number of schools to gain acceptance before extending the reform to the rest of the system; (ii) improve the school environment by supporting rehabilitation and repair of schools; and (iii) enhance the ability of national and regional institutions to design, plan for, and implement sustainable education reforms. The project has three components:

#### *Education Programme Quality*

This component is designed to: introduce decentralized, cost-effective, sustainable, integrated, school-based quality improvements; and develop, test and implement new and more relevant multi-level common curricula at the secondary level (Grades VII-IX) in four core subjects: language arts, mathematics, science and social studies. Technological subject matters will be included in the science curriculum. Also included in this component are:

- increased availability of textbooks and other instructional materials and equipment;
- in-service teacher training for delivering the curriculum effectively and efficiently;
- training of and support to principals in effective school management, including educational leadership and community mobilization.

#### *School Environment*

The SSRP supports: building rehabilitation and renovation; extension; construction of multi-purpose laboratories; acquisition of furniture; and emergency repair works at non-pilot secondary schools.

#### *National and Regional Institutional Strengthening*

The project also supports a number of interventions designed to improve the general performance of the education system. These are:

- the development and implementation of new budgeting guidelines;
- the development and implementation of strategies to improve the overall effectiveness of education administration;



- support for a nationwide physical facility survey of secondary schools;
- support for the continuation of the school mapping exercise;
- support for a Social Awareness Campaign designed to inform the public about the objectives, benefits and progress of the SSRP.

An Organization Capacity Assessment done at the end of the second phase of the Primary Education Improvement Project (PEIP), informed the MOE of the need for reformation to increase its effectiveness. Some of the recommendations made in this Capacity Assessment, became the reference point for the present Public Sector reforms within the MOE that are being financed and managed by an IDB funded project, the Basic Education, Access and Management Support (BEAMS). The main objective of these reforms is for the MOE to become a more cohesive and more effective entity, with a high level of accountability. The restructuring of Central Ministry's Organizational Structure, the re-organizing of Central Ministry's Personnel Section; the method of recruitment of teachers and Ministry's staff; the effective decentralization of the Georgetown Education District from Central Ministry, are some areas being addressed under these reforms.

Finally, in its most recent Strategic Plan of 2003-2007 the Ministry reiterated its intention to actively involve the community in education delivery and management. The process for the amendment of the Education Act will further support this plan since school governance by boards and the decentralization of education management to regional stakeholders are two major issues to be addressed.

## Laws and other basic regulations concerning education

The **Constitution** does not enshrine a right to education, but Article 27 confers on "every citizen [...] the right to free education from nursery to university as well as at non-formal places where opportunities are provided for education and training." Article 28 promises every young person the right, *inter alia*, to ideological, social, cultural and vocational development. The Parliament may, by law, provide for the enforcement of these in a court or tribunal "only where and to the extent to which (Parliament by law so) provides [...] and not otherwise" (Article 39, Constitution of the Cooperative Republic of Guyana, Constitutional Amendment Act No. 1, 1988).

The Constitution provides for a system of State controlled and directed system of education. Children are protected from compulsory religious education and citizens are conferred "freedom of conscience and religious beliefs and observance." The Constitution also permits the imposition of restrictions by the State on teachers rights to freedom of expression and freedom of association, providing that the restrictions are required for the proper performance of their functions and are "reasonably justifiable in a democratic society".

The Education Act makes provision for the appointment of attendance officers in order to enforce compulsory attendance. Magistrates are given powers to deal with offences connected to the non-attendance of school age children. The Act also



provides for a National Council for Education to advise and make recommendations to the Minister of Education on matters relating to all levels of education.

The **Secondary School (Admission) Regulations** state that no person shall be admitted to a secondary school unless he/she has attained the specified score and has been allocated a place or a free place. However, the Ministry of Education may permit a governing body to admit a student to a secondary school even though he/she did not qualify to take the examination on account of his/her age (i.e. being over 11 years of age).

The **President's College Act** of 1990 established a College managed by a Board of Governors with the aim of providing “a place of education, learning and research of a standard required and expected of a secondary school of the highest standard and to promote the advancement of knowledge and the diffusion and extension of arts, sciences and technology”. Students are admitted into this College on the basis of their performance at the Secondary School Entrance Examination.

The **Education Act** was enacted in 1876 and was amended in 1949, 1961, 1972, 1975 and 1976. Many changes have been made in the education system without regard to the legal presumptions governing education and, as a result, many of the existing enactments are outdated and irrelevant. Private schools in Guyana have only been encouraged since the 1990s and they are not given any assistance by the State (Anthony, 1993). A process has begun for a new Education Act to ensure that the education service provided is more relevant to Guyana's present needs. Some areas to be amended address the following:: effective decentralization of education to the regional level; restructuring education management to allow Central Ministry to be a strictly policy-making entity with more responsibility for monitoring and evaluation, and less of an implementer of education policies; and re-defining the roles and functions of Central Ministry officials

## **Administration and management of the education system**

Guyana gained its independence from the United Kingdom in 1966, and now has a parliamentary government headed by an Executive President. Ministers are chosen by the President from the leading political figures in Parliament, but also include an unspecified number of non-elected ministers generally recruited from the professional and public service. Ministers of Education at various times have been appointed from amongst the ranks of government members of Parliament. Some have been non-elected technocrats. The **Ministry of Education** (formerly the Ministry of Education and Cultural Development—MOECD) has overall responsibility for the functioning of the education system.

The Ministry of Education was restructured in 1989, as a result of re-assignment and the addition of responsibilities. Child and family welfare, for example, was put under the aegis of this Ministry, while culture formed part of the Ministry of Culture and Social Development for which the Vice-President and Deputy Prime Minister had overall responsibility (Paul *et al.*, 1991). The Ministry was reorganized again in 1991, and the Department of Culture once again was put under the aegis of the Ministry of Education, which has been renamed the Ministry of



Education and Cultural Development. The Child and Family Welfare Division went to the Ministry of Labour, Human Services and Social Security.

The **Permanent Secretary** (PS) of the MOECD has overall responsibility for the management of the education system which includes the formulation, co-ordination and implementation of plans. The PS is assisted by two deputy permanent secretaries, one education planning officer and one field auditor. The Deputy Permanent Secretary (Administration) supervises all personnel matters, general administration services and security. The Deputy Permanent Secretary (Finance) oversees all matters related to finance, materials, distribution, stock control, transport, buildings and maintenance. The education planning officer heads the Planning Unit and is responsible for education plans, research and evaluation. The field auditor heads the Internal Audit Section and ensures that accounting systems are in place.

The Chief Education Officer (CEO) has overall responsibility for professional matters throughout the system. The CEO is assisted by three deputy chief education officers (DCEOs). The DCEO (Development) is responsible for the Cyril Potter College of Education and the National Centre for Educational Resource Development. The DCEO (Administration) oversees management of the school system, and supervises the assistant chief education officers responsible for nursery, primary and secondary schools. The DECO (Technical) is in charge of pre-vocational, vocational and technical education. Within the MOECD, there is also an Inspectorate headed by an assistant chief education officer who is accountable to the CEO.

Guyana is divided into eleven administrative regions (and education districts), including Georgetown, the capital, which is administered separately. At the regional level, education is the responsibility of the **Regional Democratic Councils** and their chairpersons, who supervise regional education officers (REDOs) and teachers. These regional officers come within the political supervision of the **Minister of Regional Development** who, through his Permanent Secretary and Secretariat, controls the budget, maintenance and construction. The MOECD remains responsible for overall educational policies and co-ordinates, monitors and evaluates the provision of educational services in the regions. The Ministry also remains responsible for examinations, curriculum, teacher training, educational planning and macro-level research. The staff of the regions include the regional education officers, education officers, education supervisors and school welfare officers.

Some of the statutory powers of the CEO (e.g. to open or close schools, grant leave of absence to teachers) have been delegated to the REDOs. Monthly meetings of all REDOs and senior professional officers of the Ministry allow for the dissemination of information and for reporting and feedback.

While REDOs have responsibility for all educational activities in their regions, education officers and supervisors have more specialized responsibility at the nursery, primary or secondary levels. The Ministry also has officers who specialize in specific levels. In particular, separate assistant chief education officers have overall responsibility, respectively, for nursery, primary and secondary schools across the regions.



**Subject Committees** have been established in each region for development work on each subject area. Subject committees are made up of experienced teachers from clusters of schools. They focus on the appropriateness of subject objectives, content, teaching strategies, materials and evaluation procedures. Members are expected to share the findings of the Committee with their school colleagues and Regional Subject Committees group representatives of the various subject committees within each region. Representatives of Regional Subject Committees form National Subject Committees for most subject areas. The National Subject Committee feeds information to the Ministry and makes recommendations on the curriculum.

The **Inspectorate** is responsible for analyzing and reporting on the reasons for success or failure of the programmes and activities implemented within the education system. The team is, therefore, concerned with both formative and summative evaluation, and with recommendations for appropriate remedial action. An important aspect of the work of the Inspectorate is the evaluation of students' performance at the various levels of the school system in relation to regional and national norms. The Inspectorate has subject specialists for each of the core curricular areas—language arts, mathematics, science and social studies—as well as specialists in school organization and management.

The **National Centre for Educational Resource Development** (NCERD) is an arm of the Ministry which is concerned with the developmental aspects of the work of the MOECD. It has a Director who is responsible for the overall co-ordination of the following units: the Curriculum Development Unit, the Test Development Unit, the Learning Resource Centre, the Broadcast to Schools Unit, and the Materials Production Unit.

The Curriculum Development Unit has responsibility for the development of curriculum guide for teachers in primary schools and in Grades VII-IX of secondary schools. Under specially-funded projects, the unit has also developed school textbooks for use at the primary and secondary levels. The Test Development Unit prepares tests such as: the Secondary School Entrance Examination (SSEE) which is taken by children at the age of 11+; the Secondary School Proficiency Examination (SSPE), Parts 1 and 2, which is taken by students in Forms III and IV, respectively, in community high schools; and the National Fourth-Form Achievement Test (NFFAT) which is taken by students in Grade X (or Form IV) to determine their suitability to sit the Caribbean Examinations Council (CXC), Secondary Education Certificate examination. The Learning Resource Centre prepares teaching/learning resource materials for schools using multimedia and loans materials and equipment (e.g. science equipment, overhead projectors, tape recorders, etc.) to schools for specialized periods. The Broadcast to Schools Unit prepares exemplary lessons on various topics—in areas such as mathematics, social studies, science and music—which are aired on national radio in the early afternoon. Teachers are given guidance on the necessary preparation of the pupils for the broadcast and on the needed follow-up. The availability of printing facilities makes it possible for the Materials Production Unit to undertake printing jobs for the MOECD. The grouping of these units into one centre permits collaboration and integration of effort and activities.

On-the-job training is provided through work-study attachments in public and private firms. The apprenticeship scheme is run by the Board of Industrial Training



which comes under the **Ministry of Labour**. The **Ministry of Public Service** organizes overall training in the public service, and administers the Government of Guyana Awards Scheme for undergraduate and short courses. The **National Data Management Authority** processes examination results.

## Structure and organization of the education system

### Guyana: structure of the education system

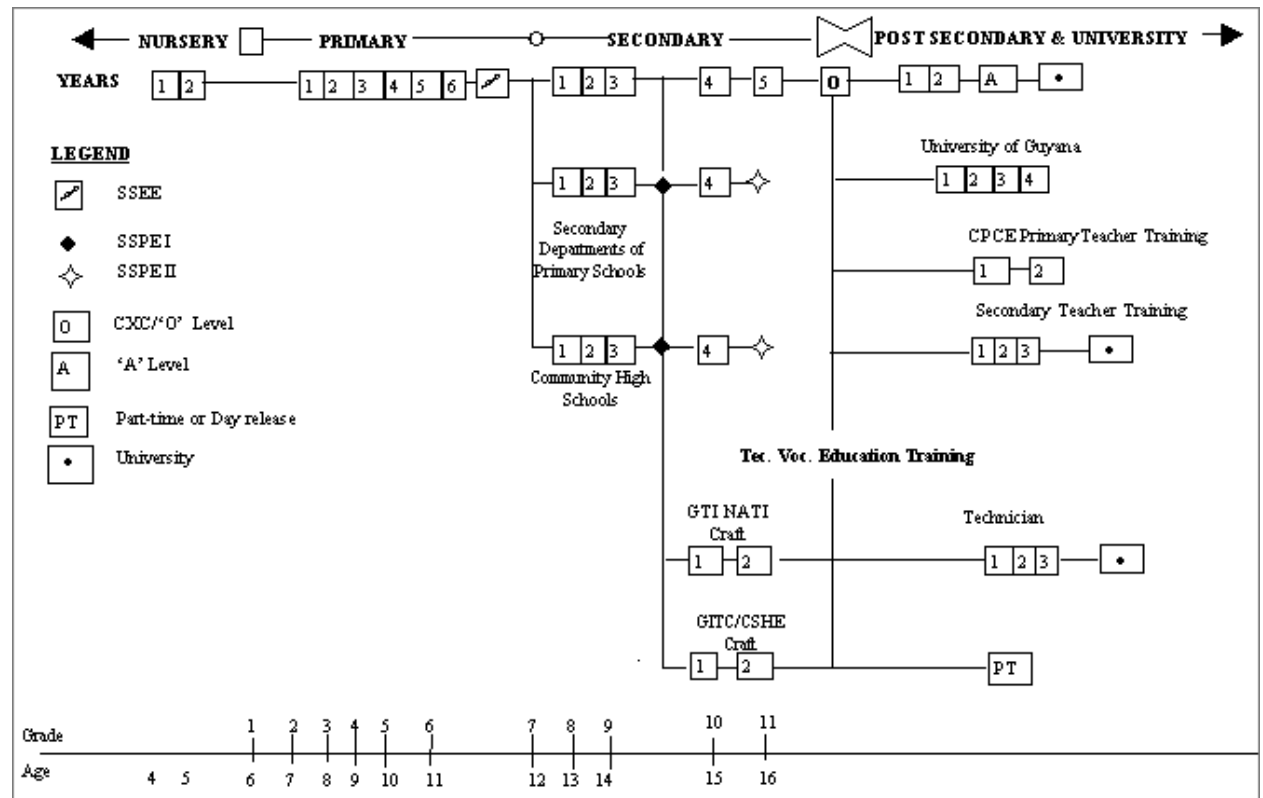

Guyana's education system comprises the following educational levels: nursery, primary, secondary, technical and vocational education, teacher training and university. Special schools cater to students who are: physically and mentally handicapped; slow learners; delinquents or in especially difficult circumstances. Continuing education is provided by the Adult Education Association and the Institute of Adult and Continuing Education—an arm of the University of Guyana—which was recently renamed the Institute of Distance and Continuing Education.

### Pre-school education

Nursery (pre-school) education is available to children from the age of 3 years and 6 months. Attendance is not compulsory. Pupils spend two years at nursery school. First-year pupils are designated as 'Level 1' and those in the second year 'Level 2'. The programme is delivered in nursery schools or in primary schools with nursery classes.



## Primary education

Children are admitted to primary school at the minimum age of 5 years and 9 months. Primary education is compulsory. The programme lasts six years and at the age of 11+ the pupils sit the Secondary School Entrance Examination (SSEE). Pupils are awarded places in secondary schools depending on their performance in the SSEE. Those with the highest scores are awarded places at President's College, while those with lower performances are placed in community high schools or in the secondary departments of primary schools. Community high schools offer a four-year programme oriented towards the acquisition of pre-vocational skills. Primary schools with secondary departments offer a four-year programme that is similar to that offered by community high schools. The ages of the students range from 11 to 14 years.

## Secondary education

Students who pass the SSEE are admitted into general secondary schools, offering a five-year programme that prepares students to sit the Caribbean Examinations Council (CXC), Secondary Education Certificate and/or the General Certificate of Education, Ordinary-level (GCE O-level) examinations. While the programme in these schools is largely academic in orientation, students are also prepared to take the CXC in a wide range of technical/vocational subjects. Students who gain at least five passes with high grades in the CXC/GCE examinations can proceed to Form VI in designated senior secondary schools, and at the end of the two-year programme students sit the GCE Advanced-level examinations.

Technical education and vocational training at the post-secondary level are offered in three technical institutes, an industrial training centre, the Carnegie School of Home Economics and the Craft Production and Design Division. These institutions train students above the age of 16 in a wide range of technical and vocational areas. Most courses are of two years' duration leading to a technical certificate, a technician diploma or a certificate of proficiency.

The University of Guyana offers four-year Bachelor's degree courses, one-year post-graduate diploma programmes and two-year Master's degree programmes. Undergraduate studies leading to the award of certificates and diplomas are offered in a variety of fields, including public administration, education, social work, accountancy, etc. The average contact hours per course is four hours a week. On average, a student carries a total of four courses per semester, giving an average study time of sixteen hours per week.

The school year consists of thirty-nine weeks at all levels.

## The financing of education

The education system is primarily financed by the central government. Private schools that have opened up since the early 1990s are self-financing. At the University of Guyana cost recovery measures have been introduced, thereby making it compulsory for students to pay tuition fees.



The government input into the financing of schools is about 95%; some schools, however, must more or less depend on the contribution from the community and the private sector. In lieu of financial assistance, the community assists schools by donating land, supplying construction materials, electrical and plumbing fittings. The extent of such contributions is evident in the case of the elite secondary school—the Presidents College. This school, which was built in the mid-1980s, received donations of materials in excess of G\$600,000 and financial contributions of over G\$4 million (Paul *et al.*, 1986).

Non-governmental organizations (NGOs) such as the Lions Club and Rotary assist the education system in various ways. For example, the Lions Club partially financed a school for children with special needs which was built in Region VI in 1993-95 on a land donated by the New Building Society. In addition, Parent-Teacher Associations organize fairs, sales and give monetary contributions to schools, although the total contribution is often not disclosed to the Ministry of Education, for fear that budgetary allocation of the school will be reduced.

Another important source of financing for general secondary schools, in particular, are the Old Students Associations (OSA). These consist of former students of the school, many of whom live abroad and organize ‘chapters’ in cities such as New York and Toronto. OSAs provide gifts and equipment to schools. Some even provide the funds necessary to supplement teachers’ salaries or to hire security guards for the school premises. Government agencies and public corporations also serve as ‘adoption agencies’ for selected schools. They contribute to self-financing activities of the adopted school by, for example, sponsoring a fund raising event and paying for advertisements.

It is not possible to ascertain precisely the percentage of the schools’ budget which is met by finances from the sources described, since school principals do not always report the totality of funds raised by their schools. The Ministry of Education exercises strict control over the use of funds generated directly by the school. Records have to be kept and prior approval has to be sought from the Ministry before schools can use the funds generated for any purpose.

The Government of Guyana remains committed to “being responsible for meeting the cost of education up to age 16” (MOECD, 1995, p. 7), but at the same time wants to involve the community and community organizations—including NGOs—in the maintenance of the infrastructure of schools and the provision of resources, *inter alia*. There are plans to increase primary education’s share of the budget as well as to rationalize the budget of secondary education “by eliminating major expenditures that are of secondary importance” (*ibid.*, p. 22).

Whilst the government finances schools that cater to children with special needs who reside in the city and its environs, the trend is to support the approach of the Community Based Rehabilitation Programme which puts the onus on the local communities to provide services for children with special needs particularly in the rural and hinterland areas.

While the present government does not support the payment of fees at the secondary level, it actively encourages the establishment of private schools so as to



encourage cost sharing of educational provision. Funds for training in technical/vocational areas may well be provided in the future from a tax on employers. Legislation is being introduced in this regard.

The University of Guyana is expected to continue raising some of its funds through the cost recovery scheme now in place. Within this scheme, the government provides student loans which are repayable over a fifteen-year period following completion of studies. The scheme meets about 60% of the cost of running the university. The institution is also expected to raise funds through the marketing of consultancy services of the staff and generate income through the development of a business arm of the university. To mark the thirtieth anniversary of the University in 1993, a fund-raising drive was held to start an Endowment Fund. This was accomplished through the efforts of the University's Office of Resource Mobilization and Planning with the assistance of the Canadian Executive Service Organization (Vice-Chancellor, University of Guyana, 1993).

In its thrust to improve the quality of primary education, the Government of Guyana has relied heavily on the Inter-American Development Bank (IDB) to fund its Primary Education Improvement Project (PEIP). The IDB has provided 90% of the funds. The United Nations Development Programme (UNDP) provided 90% of the funds for the development of textbooks for use in the lower forms of secondary schools. A grant from the European Union for the Sector Programme (Education) has been used mainly in a ten-month programme for the upgrading of primary school teachers in the hinterland regions of Guyana to a point where they can pursue professional preparation at the College of Education. In the second phase of this project, funds were used for the preparation of distance teaching materials. In 1996-97, a World Bank loan of approximately G\$63 million financed the Secondary School Reform Programme (SSRP), which is designed to improve the quality, relevance, equity and efficiency of secondary education.

## **The educational process**

### **Pre-primary education**

Among its objectives, the Guyana Nursery Education Programme emphasizes the need to: encourage self-initiated activities through educational experiences based on the continuing analysis of each child's mode of learning; develop in children self-confidence and a healthy self-concept through the promotion of their mental and physical health; and provide a learning environment which will challenge and support exploration and problem-solving and promote creativity.

The nursery programme emphasizes freedom of expression through language, music, art, drama, and dance. The average size of nursery classes is between 16 and 25 children. Because of the shortness of their attention span, they are taught in 15-20 minute sessions, either as one large group or in smaller groups. Nursery schools usually operate between 9:00 and 12:00, so that the sessions last only half day. There are no formal examinations at the nursery level. Continuous school-based assessment is done to ascertain the readiness of the children for more advanced tasks. Check lists,



anecdotal records and cumulative record cards are the evaluative instruments used at the nursery level (Rodrigues, 1994).

This curriculum of Early Childhood Education spans the two years of pre-primary (nursery) and the first two years of primary education. It was introduced to lay the foundation for early literacy and numeracy through its child-centred approach to pre-reading, pre-writing and the teaching of life skills. This reform is currently being implemented through BEAMS. The innovations introduced under BEAMS include: a balanced approach between the whole word and phonic methods to the teaching of reading; and the teaching of mathematics using the Interactive Radio Instruction Programme (IRI), an activity-oriented approach, intended to encourage a change in the role of the teacher from repository of knowledge to facilitator of learning.

These innovations stimulated changes in other key areas such as teacher training and the acquisition of teaching/learning materials. As a result, BEAMS also focuses on the inclusion of these strategies in the curriculum of the Teacher Training College, the Cyril Potter College of Education (CPCE), the revision of the main textbooks and the acquisition of complementary text books/materials for the pre-primary and primary levels.

**Number of nursery classes by level and size**

Level classes	Class size and number of children per class						Total No.
	Children	Children	Children	Children	Children	Children	
	1-10	11-15	16-20	21-25	26-30	31+	
1	56	97	325	250	44	16	788
2	35	89	251	287	79	16	757
Total	91	186	576	537	123	32	1,545

## Primary education

The main objectives of primary education are:

- to provide each pupil with basic communication skills;
- to develop basic numeracy and computation skills;
- to help each pupil to think and solve problems;
- to provide pupils with experiences that make them aware of beauty in the environment and to encourage them to express their ideas and feelings through a variety of creative activities;
- to enhance child's psycho-motor development;



- to help pupils to interact with others in socially accepted ways;
- to help each pupil develop a feeling of self-worth and self-reliance;
- to develop in each pupil a feeling of patriotism.

The curriculum consists of the following subjects: language arts, reading, mathematics, social studies science, health education, art and craft, music and singing, and physical education. The core compulsory areas are: language arts/reading, mathematics, social studies and science.

Language arts/reading and mathematics are treated as the primary areas which are taught daily five thirty-minute periods each week. Science and social studies are each given at least two periods each week. Music is taught formally only in schools where there is a specialist teacher with the necessary skills and where a piano or some other musical instrument is available. The primary school day lasts approximately five hours excluding lunch break. The Life skills, Health and Family Life Education, Guidance and Citizen curriculum is being included in the curricula of grades 1-9 (the primary level and the first three years in the secondary level). Its aim is to provide teachers with an integrated and consistent approach to the application of value education. Student should learn critical life skills that are necessary for applying values, become independent thinkers, and active, participating responsible citizens. This curriculum aims to serve two main purposes: to encourage students to i) inculcate essential life skills including the making of wise choices; and ii) acquire the values that will allow them to live peaceable in the pluralist, multicultural Guyanese society. The main themes of this curriculum are education, family, health, human rights, and human sexuality that will be taught from Grades 7 to 9. It is also being taught at the primary level.

Pupils are assessed informally on their sense of responsibility, courtesy and thoughtfulness, on their ability to work independently, with speed and cheerfulness. Their hygiene, regularity of attendance at school, punctuality and their homework are also assessed. At the end of primary education, pupils sit the Secondary School Entrance Examination (SSEE) for placement in one of the types of secondary schools. Pupils with the highest scores are offered places at the President's College, a residential school which provides a wide range of academic and extra-curricular programmes. Those with lower performances are placed in community high schools or in the secondary departments of primary schools. The ratio of trained teachers to pupils is on average 1:48. When untrained teachers are included, the average teacher-pupil ratio is 1:25 (MOECD Education Planning Unit 1996).

Primary schools in the rural and hinterland areas tend to have classes with 30 pupils or less. In the capital city, Georgetown, however, most of the classes have between 41 and 55 pupils, with some classes exceeding 66 pupils.

Under BEAMS, the MOE is piloting a Continuous Assessment Programme at grades 2, 4 and 6, which allows teachers to identify weaknesses and strengths and make appropriate interventions. The pupils' performances are recorded at the three stages and it is proposed that this will be used instead of the SSEE for entrance to secondary schools.

### Size and number of primary classes (1994/95)

	Size and number of classes									
Size	1-10	11-20	21-30	31-35	36-40	41-45	46-55	56-65	66+	Total
Total	667	393	495	376	369	321	331	81	70	3,103

### Repeaters by grade (1994/95)

Pupils repeating in the same grade						
Prep. A	Prep. B	Std. I	Std. II	Std. III	Std. IV	Total
1,358	498	614	444	331	895	4,140

## Secondary education

Secondary education is offered in general secondary schools, community high schools (CHSs) and secondary departments of primary schools. Its main purpose is to provide students with opportunities to acquire the skills and attitudes that would equip them for beneficial employment and/or entry into tertiary level institutions.

The four-year programme offered in CHSs and the secondary departments of primary schools is oriented towards the acquisition of pre-vocational skills. The students study the compulsory academic subjects—English, mathematics, social studies and science—in addition to health education, physical education, music and drama, in cases where there are teachers with the necessary qualifications. Approximately 60% of the schools timetable is devoted to the academic subjects in the first three years of secondary schooling. Technical subjects are also taught, such as agriculture, home economics, art and craft, industrial arts and business education. The choice of technical areas depends on the resources available to the school. About 40% of the school's timetable is devoted to these subjects in the first three years of study. Students then sit the Secondary School Proficiency Examination (SSPE), Part 1. Those with the highest grades are then transferred to a general secondary school, where they pursue a more academic curriculum. The other students remain in CHSs or in the secondary department of the primary school and spend their fourth year specializing in the pre-vocational area for which they have shown some aptitude. In this final year about 60% of the timetable is devoted to the pre-vocational area. The SSPE, Part 2, is taken at the end of the fourth year. However, some 60% of the students in CHSs are reported to drop-out of school at the end of the third year (Williams, 1993).

General secondary schools offer a five-year programme which is largely academic. In the first three years all students have to study English, mathematics, social studies and/or science, with more teaching periods being given to English and mathematics. A period is forty-minute long. Health education, music and drama are also taught in these schools, as well as some pre-vocational skills in home economics and agricultural science. The availability of the necessary equipment, tools and teachers with the appropriate training determines which skills are taught in particular schools.



At the end of the third year the students choose the subjects that they wish to study for the Caribbean Examinations Council (CXC), Secondary Education Certificate and the General Certificate of Education, Ordinary level (GCE O-level) examinations. Students have a wide range of subjects from which to choose, depending on the availability of a teacher qualified to teach the subject in their school.

The average ratio of trained teachers to students is 1:42, while the average ratio of trained and untrained teachers to students is 1:22.

In its drive to achieve Universal Secondary Education (USE), the MOE is striving to increase access to quality secondary education by: 1) eliminating the unequal three tiered system and 2) restructuring the curriculum to include other subjects that will provide secondary school leavers with requisite skills for the world of work and/or higher education. These reforms are being piloted through three main donor-funded projects: the Secondary School Reform Project (SSRP), Guyana Education Access Project (GEAP), and the Basic Competency Certificate Programme (BCCP).

The MOE, in its ESP 2003-2007 and Secondary Policy Paper declared its intention to:

- Eliminate the three-tiered system by converting CHS and Primary Tops to General Secondary Schools (the achievement of USE).
- Improve physical facilities and increase the number of secondary schools.
- Develop a unified curriculum for all secondary schools for Grades Seven to Nine.
- Up-grade through training the human resource available in all levels, particularly the CHS' and the Primary Tops.
- Increase the number of qualified teachers in the secondary system.
- Increase the financial resources for non-salaried expenditure.
- Reform the curriculum to include alternative learning paths.
- Improve the organization and management of schools.
- Increase community participation in school management.

Through the Secondary School Reform Programme (SSRP) which concluded in 2004, and the Guyana Education Access Project (GEAP) that was completed in 2003, the Ministry began to address all of the above except the increase of financial resources for non-salaried expenditure which is being tackled by another project—the Basic Competency Certificate Programme (BCCP).





According to the draft document, the rationale of the BCCP is as follows: “In order to have a cadre of skilled personnel at the engineer, technician and craftsman levels available to the nation, it is necessary to provide basic training at the secondary level. The BCCP at grade 10 is intended to satisfy this need. This initiative will provide an opportunity for more secondary school students to pursue technically oriented careers, thereby alleviating the shortage of skilled persons. The certificate will facilitate, employment, access to CSEC and post-secondary institutions, and also serve as an entry requirement for apprenticeship training. To enable students to decide on their subjects of specialization for the BCCP, they will be exposed to a general introductory programme in Agricultural Science, Visual Arts, Home Economics, Industrial arts and Vocational Guidance and Counseling from Grade 7 to Grade 9.” The duration of the programme shall be for one academic year. Students who complete the programme by the end of the academic year will be certificated. The programme may be extended for an additional term to accommodate those students who did not satisfy the minimum requirements for certification. Student wishing to remain in the secondary school system may spend an additional one to two years to pursue CSEC.

<b>Articulation in the Secondary System (Grade 10)</b>						
<b>Compulsory Core Areas</b>						
BCCP	Practical Option Areas: Agricultural Science, Visual Arts, Home Economics, Industrial Technology	Work study/ Work attachment	English Language	Mathematics	Intgrated Science	Social Studies Including Health and Family Life Education and Citizenship Skills
CSEC related study areas:	Agricultural Science, Visual arts, Home Economics, Industrial Technology	Grade 10 Work Study/Work attachment	English A	Mathematics	Integrated Science	Social Studies History Economics

<b>Options following Grade 10</b>
<p><b>BCCP student graduates and continues in the secondary system</b> CXC year 1 or 2 in Mathematics/ English/Industrial technology/Home Economics/Visual Arts/Social Studies/Integrated Science or any available subject for which they show aptitude. Year of entry dependent on attainment grade at the end of BCCP.</p>
<p>BCCP student graduates and exits Secondary System at the end of grade 10. Technical Institute or equivalent Craft level course</p>
<p><b>BCCP student graduates and exists Secondary System at the end of grade 10.</b> Entry to Post Secondary Institution, apprenticeship training and/or employment</p>
<p><b>CSEC student continues in the secondary system</b> Continues into year 2 dependent on year 1 attainment.</p>



Subject Groups Form 4 BCCP						
Practical Skills  (300 hrs)	Work Attachment  (140 hrs)	Study/Work	English Language  (120 hrs)	Mathematics  (120 hrs)	Integrated Science  (90 hrs)	Social Studies including HKLE and Citizenship  (120 hrs)
Technology and basic skills covering 'key' practical, problem solving and creative thinking areas.	<p>Awareness of opportunities in employment, education and training.</p> <p><b>TERM 1</b> Visits and presentations by members of the local business community. Three work-related visits (15 academic hours) given to business/manufacturers.</p> <p><b>TERM 2</b> Job shadowing- a total of 25 hours</p> <p><b>TERM 3</b> Work attachment or school based project a total of 100 academic hours (4 weeks)</p>	Literacy Skills based on areas of concern highlighted in the CXC report papers and MOE experience integrated with the specific practical options	Numeracy Skills based on areas of concern highlighted in the CXC report papers and MOE experience integrated with the specific practical options	Integrated Science based on essential cross curricula areas of general "science" based study integrated with the specific practical options. Referenced to the CARICOM science technology guidelines.	Focus on student interpersonal skills and awareness of their position or stake in society, as a support to and integrated with the Work Study/Work Attachment programme and the Specific practical options	

Source: The Basic Competency Certificate Programme Draft.

## Assessing learning achievement nationwide

In their final year of primary school, pupils sit the Secondary School Entrance Examination (SSEE). This is really a selection device for determining which pupils will gain entry to the more prestigious general secondary schools. Pupils are examined in English, science, mathematics and social studies. The tests are largely multiple choice with some essay questions. Of the pupils who sit the SSEE in a given year, approximately one-third are selected for the general secondary schools (more girls than boys).

The Secondary School Proficiency Examination (SSPE) is administered in two parts to students who pursue the community high school programme. Part 1 is taken at the end of the third year (Form III) and Part 2 in the final year (Form IV). The Education Planning Unit of the MOECD (1995) reports that in 1993, 2,917 and 2,712 students passed the SSPE Parts 1 and 2, respectively. This represents a pass rate of 79% and 88% for Parts 1 and 2, respectively. This examination is held in low esteem in the society and particularly amongst employers.



The National Fourth-Form Achievement Test (NFFAT) was introduced in 1988 as a compulsory examination to be taken by Form IV students in general secondary schools. This examination replaced the usual end-of-year examinations constructed and administered by individual schools. The main purpose of NFFAT was to identify those students who were likely to do well in the CXCSEC at the end of the fifth year of secondary schooling. The expectation was that if only the students identified by NFFAT were allowed to sit the CXC examinations, the overall performance of students at these examinations would improve, in comparison with their peers in other Caribbean territories.

NFFAT, however, encountered a number of problems, largely due to lack of adequate funding, poor management and administration of the examination and tardiness in finalizing the results. It did not have the impact on performance at the CXC examinations as expected. The name of the examination has since been changed to the 'Pre-CXC examination. It is no longer managed by the National Centre for Educational Resource Development, but has become the responsibility of individual schools.

The Caribbean Examinations Council Secondary Education Certificate (CXCSEC) examinations are taken at the end of Form V in general secondary schools. The examinations are also taken by private candidates. By offering three schemes of examinations—basic, general and technical proficiency—CXC caters to a wide range of abilities and interests. The general proficiency is more demanding than the basic proficiency scheme and is intended to provide a foundation for advanced study. The technical proficiency scheme is intended for those candidates who require a school programme with a greater practical orientation.

The CXCSEC is awarded in five grades, but only grades I and II are normally regarded as pass. Some subjects have a school-based assessment (SBA) component. This involves the teacher's evaluation of coursework assignments, projects and practicals set over a period of about two years prior to the final examination. The SBA component is worth between 20% and 40% of the final mark.

The performance of Guyana's secondary school students at the CXCSEC is very poor compared to their peers in other Caribbean territories. Of 16 or 17 countries that enter students annually for the examination in the various subjects, in most cases Guyana ranks last or next to last. The following tables present typical results.

**A comparison of the performance in CXC English A (general proficiency level, grades I and II) of candidates from selected Caribbean countries (1994-96)**

Territory	1994			1995			1996		
	No. Entered	No. Passed	% pass	No. Entered	No. Passed	% pass	No. Entered	No. Passed	% pass
Barbados	2,390	1,398	58.50	2,419	1,233	50.98	2,333	1,406	60.26
Belize	973	378	38.95	1,064	405	38.07	1,083	551	50.88
Guyana	4,636	663	14.31	5,003	580	11.63	5,123	1,000	19.52
Jamaica	15,592	5,553	35.62	16,104	4,465	27.72	16,173	5,626	34.78
Trinidad & Tobago	19,889	7,902	39.73	19,482	7,145	36.68	19,483	9,200	47.22

**A comparison of the performance in CXC Mathematics (general proficiency level, grades I and II) of candidates from selected Caribbean countries (1994-96)**

Territory	1994			1995			1996		
	No. Entered	No. Passed	% pass	No. Entered	No. Passed	% pass	No. Entered	No. Passed	% pass
Barbados	1,586	791	49.87	1,660	803	48.83	1,605	787	49.03
Belize	802	313	39.02	864	401	35.99	842	304	36.11
Guyana	4,052	633	15.62	4,141	795	19.20	4,313	719	16.67
Jamaica	14,654	3,458	23.60	14,917	4,176	28.00	15,026	3,643	24.25
Trinidad & Tobago	17,666	5,602	31.71	17,658	6,108	34.59	17,511	6,144	35.09

Source: Compiled from tables in: (a) Report on Administration of the 1994 Examinations, December 1994, CXC Headquarters;

(b) Report on Administration of the 1995 Examinations, December 1995, CXC Headquarters;

(c) Report on Administration of the 1996 Examinations, December 1996, CXC Headquarters.

## Higher education

Technical education and vocational training at the post-secondary level are offered in three technical institutes, an industrial training centre, the Carnegie School of Home Economics and the Craft Production and Design Division. These institutions train students above the age of 16. Non-tertiary post-secondary institutions are managed by boards appointed by the Government except for the Labour college which is governed by a board nominated by the Trades Union Congress.

Teacher training programmes are offered by the National Centre for Educational Resource Development (NCERD), the Cyril Potter College of Education (CPCE) and the University of Guyana (UG). NCERD focuses on in-service teacher training with special emphasis on the acquisition of resource materials.

The CPCE has its main complex at Turkeyen, near to the university. It also has two centres in Regions VI and X. It offers a two-year in-service training programme for nursery and primary school teachers and a three-year pre-service training programme for secondary school teachers. There is also a two-year pre-service programme for primary school teachers.

Guyana has one university which is headed by a Chancellor with the Principal and the Vice-Chancellor as the academic and executive heads. The Chancellor is the chairman of the University Council, the governing body of the institution which is appointed by the government. The Academic Board regulates and superintends the education and discipline of students of the University. Other important officers are the registrar who undertakes all matters pertaining to the registration of students, the bursar and the deans of the faculties. There is no mechanism external to the university for evaluating its performance. The university has formal procedures for assessing its staff members and its financial management is audited each year by officers from the office of the Auditor General.

The University is regulated by the University of Guyana Act that governs the registration and regulation of higher education in general. There are however laws and statutes concerning particular professions such as medicine, pharmacy and engineering which have implications for higher education. A national system of accreditation is being defined.

The University offers four-year Bachelor's degree courses, one-year post-graduate diploma programmes and two-year Master's degree programmes in education, literature, history, geography, and natural sciences. It also offers post-graduate diplomas in education, international relations, development studies and translation. Undergraduate studies leading to the award of certificates and diplomas are offered in a variety of fields, including public administration, education, social work, accountancy, etc. The average contact hours per course is four hours a week. On average, a student carries a total of four courses per semester, giving an average study time of sixteen hours per week.

### **Enrolment at the Cyril Potter College of Education (1990-93)**

<b>Programme</b>	<b>1990</b>	<b>1991</b>	<b>1992</b>	<b>1993</b>
Foundation	99	45	121	82
Nursery	73	55	58	100
Primary	212	199	267	395
Secondary	69	45	72	75
Tech./Voc.	100	74	70	41
<b>Total</b>	<b>553</b>	<b>418</b>	<b>588</b>	<b>723</b>

*Source:* Education Planning Unit, MOECD, 1995.

### Enrolment at the University of Guyana 1990-93

	1990	1991	1992	1993
Total	2,281	2,540	2,972	3,297

Source: Office of the Vice-Chancellor, 1993.

### Teaching staff and number of students enrolled in post-secondary and higher education institutions in 1994-95

Institution		Students			Staff		
		M	F	T	M	F	T
Guyana Industrial Training Centre		228	25	253	13	2	15
Carnegie School of	Full-time courses	5	144	149	2	12	14
Home Economics	Short-term courses	18	1,668	1,686			
# Government Technical Institute		1,382	515	1,897	80	37	117
New Amsterdam Technical Institute		494	226	720	33	13	46
* Cyril Potter College of Education		129	799	928	17	36	53
+University of Guyana		1,468	1,907	3,375	257	112	369

# Includes all full time students in Years I and II and part-time students in Years I-IV.

\* Enrolment at centres in Georgetown, Linden and New Amsterdam.

+ New and Continuing students as well as full time students at the Institute of Adult and Continuing Education.

Also includes full and part-time staff.

(Source: Compiled from data in the Education Planning Unit, MOECD, 1996).

## Special education

The problem of obtaining accurate information on the number of children in the society who need special education is exacerbated by the fact that many parents today still feel ashamed. They hide away their children who are physically or mentally handicapped, often in an attempt to shield them from an insensitive public. The society has such low regard for the handicapped that even in public buildings no provision is made for the wheelchair user or the blind. Because of its policy to provide universal primary education, the government has become involved in the provision of special education in the following ways.



Since 1976, special education teachers have been trained at the Mico College in Jamaica with specialization in education for the deaf and the hearing-impaired, mental retardation, physically handicapped, and education of the blind. The University of Guyana also offered a Certificate in Special Education during the 1980s.

Students enrolled in special education institutions follow curricula that provide for primary through secondary programmes. Five of these schools are located in the capital city and its environs.

- the David Rose School for Handicapped Children caters to the needs of predominantly deaf/hearing-impaired and mentally challenged students aged 4-25;
- the Ptolemy Reid Rehabilitation Centre deals with children who are physically handicapped;
- the St. Barnabas Special School offers a programme to help children diagnosed as having learning disabilities.
- the Sophia Special School provides training for students aged 10-18 who are socially deprived and emotionally disadvantaged;
- the Grove School for Children with Special Needs is located in Region V. It caters to students aged 6-18 who are mentally and physically handicapped;
- the Lions School for Children with Special Needs is the newest addition to the provisions for special needs. It is located in Region VI and was funded by the Lions Club and the Futures Fund, with the land for the building being donated by the New Building Society;
- the New Amsterdam Special School in Region VI is similar to the Grove School;
- the Linden Handicapped Centre in Region X caters to the needs of children with physical disabilities.

Special education schools follow the primary school curriculum as far as possible, but have a practical orientation designed to give the students skills in light handicrafts. The Sophia Special School provides training in vocational areas alongside the development of skills in literacy and numeracy.

The government has received assistance from interest groups in the society that are concerned with children with special needs. The support has come mainly in the provision of new buildings or in the renovation of existing ones.

### Student enrolment in special education institutions in the public system (1990-96)

Institution	1990	1991	1992	1993	1994	1995	1996
David Rose School	147	151	143	143	119	122	121
Ptolemy Reid Rehab. Centre	31	33	31	32	33	33	31
St. Barnabas Special School	Not available	192*	Not available				
Sophia Special School	135	154	144	162	142	174	227
Grove School	24	20	24	27	36	44	44
Lions School	Not applicable	30					
New Amsterdam Special School	12	12	19	22	22	21	25
Linden Handicapped Centre	Not available	22*	Not available				
St. Roses	21	18	18	17	17	17	14

Source: \* Education Planning Unit, MOECD, 1996. Other information supplied by Principals of the schools, June 1997.

### Staffing in special education institutions (1994-95)

SCHOOL	No. of teachers		No. of trained teachers to pupils		Ratio of trained teachers to pupils	Ratio of teachers to pupils
	M	F	M	F		
David Rose School	3	14	2	3	1:21	1:6
Ptolemy Reid Rehab. Centre	1	2	1	1	1:14	1:9
St. Barnabas Special School	4	9	2	8	1:19	1:15
Sophia Special School	2	11	1	8	1:16	1:11
Grove School	1	5	1	1	1:15	1:5
*Lions School		4		3	1:10	1:7
New Amsterdam Special School	3	1	2	0	1:11	1:6
Linden Handicapped Centre	0	3	0	0	-	1:7
St. Roses'	1	3	1	2	1:5	1:4

Source: Education Planning Unit, MOECD, 1996; *Stabroek News*, June 1995, p. 15.





## Private education

The Church played an important role in education in Guyana up to 1976 when the State assumed control of all schools in the country, and the influence of the Church was removed. Private education was not consistent with the egalitarian ideals of the government of the day.

Since the 1990s, the government has made efforts at harnessing the support of the community in sharing the costs of providing education, but the response so far has been limited. Three private schools have been established and recognized by the Ministry of Education. They are gradually being recognized in the society as offering a better quality of education than that offered in the public system.

Mae's school began in 1992 and enrolled children aged 2-3 in a play group, those between 3 years 9 months and 5 years 9 months in a nursery/kindergarten and those between 5 years 9 months and 11 years 9 months in the primary school. The maximum number of children per teacher is 25 (primary), 16 (nursery) and 10 (play group).

The school follows the curriculum of the public primary school except that it is enhanced by the teaching of Spanish and dance, music, physical education and games and use of computers, all of which are absent for the most part in public schools. Children who did not attend the nursery division are required to take an entrance test to gain admission into the primary division.

In September 1997, the school opened a secondary division which offers a core curriculum in Forms I-III consisting of: mathematics, English language, English literature, art, information technology, integrated science, physical education and games, Spanish and social studies. After the students are streamed in Form IV, they will be able to study physics, chemistry, biology, history, geography, principles of business, principles of accounting, economics and technical drawing (Mae's School Prospectus, 1997-2000). Fees from the play group to the secondary division range from G\$15,000 to G\$55,000 per term.

The New Guyana School was opened in 1994 with a nursery and a primary division. Its curriculum is guided by that in the public system, except that it puts more emphasis on religious education. Fifteen minutes per day are spent studying Christianity. The materials the school uses are in fact from the Pensacola Christian College in the United States of America. Every child is given a book for each subject. Spanish, art and music are taught and a phonics approach to the teaching of reading is used. Much emphasis is put on homework. The school opened a secondary division in September 1997. Its curriculum is similar to that of the Mae's school, except for its special attention to religious education .

The School of the Nations opened in September 1996. It follows the curriculum as outlined by the Ministry of Education, but puts more emphasis on the methodology of teaching. On-going assessment is an important part of the curricula and cumulative school records are kept. Pupils in the final year of primary education do not have to take the Secondary School Entrance Examination (SSEE) if they wish

to continue their studies in the secondary division of this school. Admission into this division is dependent on the results of continuous assessment. The school also offers art, music, physical education as well as moral education (this additional offerings are, perhaps, because the school is run by members of the Bahai faith). In the secondary division, a course on peace studies/life skills is offered. Periodic performances in the creative arts give students opportunities to develop talents in these areas.

The May Rodrigues Vocational Training Centre provides training in vocational skills for girls aged 14-18 who dropped out of school for various reasons.

In general, there are three noticeable trends. First, private schools are attracting the better qualified teachers from the public system with the result that an already ailing public system is being further depleted of its scarce human resources, including school principals. Second, private schools are excelling at the SSEE, putting out the top students. They seem to be offering a better quality of education, not only on account of their broader and more balanced curriculum, but also because of their physical conditions, supply of textbooks and smaller classes. Third, the high fees that these institutions charge (while they allow some amount of cost sharing of education with the government) effectively debar the poor, yet academically talented, from benefitting from a quality of education not available in the public system. This, in the final analysis, will make the realization of the goal of equality of educational opportunity all the more elusive. Furthermore, it has to be borne in mind that the entrance tests administered by these schools have the effect of raising their academic level of entry. This gives them an added advantage over the public system which remains saddled with the task of educating children with learning disabilities, special needs and other difficulties.

Systems need to be put in place for the monitoring of private schools to ensure that their goals are consistent with the national educational goals.

### Enrolment in private schools

INSTITUTION		1992	1993	1994	1995	1996
Mae's Under-12 Primary	School declined to provide information					
School of Nations						281
New Guyana School	Nursery & Prep A					121
	Primary			68	61	62
May Rodrigues Vocational Training Centre		65	55	72	54	66

Source: Principals of the institutions, June 1997.

### Level of training of teaching staff in private schools

SCHOOL	GRADUATE		QUALIFIED		UNQUALIFIED
	Trained	Untrained	Trained	Untrained	
Mae's Under-12			19	1	1
School of Nations	3	1	3	2	-
New Guyana School - Primary			5		
May Rodrigues Voc Tr. Centre			3		5

Source: Principals of the institutions, June 1997.

### Means of instruction, equipment and infrastructure

Although a number of nursery schools have been built with community resources, many still remain 'bottom house' schools. This means that they are held underneath houses set on concrete or wooden pillars where they are ill protected from the elements and toilet facilities and water supply are, invariably, inadequate. On the whole, nursery schools have adequate supplies of instructional materials since these are largely supplied by the parents.

Building new primary schools and rehabilitating existing ones has been a major thrust of the Ministry of Education in recent years. While one finds in certain areas in Guyana huge primary school buildings with a handful of pupils, the few in the city which are perceived as 'the best schools' tend to be grossly overcrowded, thereby putting strain on the amenities. Toilet facilities are very poor, likewise the supply of water. Many schools still do not have electricity and even the schools in the city and the towns that have electrical supply are frequently without the service on account of the problems that the country has had for over thirty years with an unreliable electricity generation system. Inevitably, this puts limitations on the use of technology in schools. Computers are usually found in private primary schools which can afford elaborate backup systems, such as small power generation plants.

Although the Ministry of Education provides free textbooks to primary schools, they are not given out in sufficient quantities to allow each pupil a personal copy that he/she could take home to do homework. The books are kept in the schools. These books, however, are quite standard and lack the variety that one would find in a typical British primary school classroom.

The infrastructure of the general secondary schools is far better than that at the primary level. Often this is because of their Old Students Associations or Parent-Teacher Associations which are more well-to-do and, therefore, afford to finance the maintenance of the infrastructure. In one of the top general secondary schools, the Old Students Association has raised millions of dollars to restore the school building. Book rental schemes in these schools, coupled with the fact that parents purchase many of the school texts needed, ensure a sufficient supply of textbooks and other instructional materials. This is not the situation, however, in community high schools



and in the secondary departments of primary schools where there is a dearth of textbooks and other instructional materials. Many of the community high schools have been vandalized and materials and equipment for their industrial arts and other technical/vocational areas have either been damaged beyond repair or stolen.

At the tertiary level, improvement in infrastructure has been made possible by loans from international funding agencies, such as the Inter-American Development Bank in the case of the University of Guyana. Maintenance of the infrastructure continues to be a problem due to lack of funds for capital expenditure.

Over the years there has been much improvement in the infrastructure of the College of Education, with a number of new buildings being put up on the campus, including computer facilities. The university also has a Computer Centre, but without sufficient computers to meet the needs of the university community. The University Library is unable to maintain a good stock of current journals due to insufficient foreign exchange to purchase these materials. This weakness has put limitations on the development of higher degree programmes, with the result that the University remains unable to offer doctoral degree programmes.

## **Adult and non-formal education**

Two institutions have the major responsibility for non-formal education in Guyana: the Institute of Adult and Continuing Education—recently renamed the Institute of Distance and Continuing Education, IDCE—and the Adult Education Association (AEA). The latter offers a wide range of evening classes to meet various needs, including literacy classes for adults. Recently, this institution has begun to offer classes for out-of-school youth and adults who wish to take CXCSEC examinations in various subjects. The AEA also works with community groups in order to address the literacy problem in their midst.

The IDCE is an arm of the University of Guyana, with the director of the institution enjoying a status comparable to that of a university dean. The institution offers a Diploma in Occupational Health and Safety which is awarded by the University. This programme attracts a small number of persons. In 1995, for example, there were only five graduates. The IDCE also offers a pre-university English course via distance education, as well as one in mathematics. The Institute has a teleconference facility provided by the Commonwealth of Learning which links its Georgetown Centre with three other centres in the country. Through this facility, in 1994 educators in Guyana were able to participate in a three-month training programme in textbooks production, sponsored by the University of the West Indies and the UNESCO International Institute of Educational Planning in Paris (IIEP).

IDCE also offers courses in conjunction with groups in the community. It is involved in training for special needs through its association with the Community Based Rehabilitation Programme which was described earlier. It collaborates with the National Association of Secretaries in the offering of a two-year programme leading to the award of a diploma. The Institute also works in collaboration with the Bahais who, in 1996, introduced a literacy project called *On the Wings of Words*. This project was inspired by the results of the Functional Literacy Survey of Out-of-School



Youth (Jennings *et al.*, 1995). It targets the age group 10-16 and provides a literacy programme for these youngsters which develops their skills in reading and their creative expression, at the same time as imbuing them all with a sense of morality through instruction in the teaching of various faiths such as Hindu, Muslim, Christianity and Bahai.

The UNDP Human Development Report (1995) gives Guyana's adult literacy rate at 97.5%. While this may represent the percentage of the population that has benefited from primary schooling, problems such as irregularity of attendance and drop-out rates have led to the accuracy of the official adult literacy rate being seriously questioned. This is especially so because employers and the society at large have frequently expressed alarm at the number of children leaving secondary school who seem barely literate and numerate. The functional literacy survey of out-of-school youth aged 14-25 revealed that 89% were achieving at a moderate to low level of functional literacy, with only 11% achieving at a high level of functional literacy. An analysis of the achievement of a sample of secondary school students on the same functional literacy test, revealed that almost 20% achieved at a high level of functional literacy. Jennings (1997) has estimated that the basic literacy rate in Guyana is in the lower 70s while the functional literacy rate is in the upper 40s to lower 50s. This suggests that over 25% of the population is illiterate and of these perhaps about 22% are absolute illiterates (i.e. cannot read or write). Jennings, however, acknowledges that further research is needed to verify these estimates.

#### **Range and functional literacy ability of out-of-school youth (OSY) (aged 14-25) and secondary school students (SSS) aged 14+**

FL level	OSY		SSS	
	No.	%	No.	%
HIGH	355	11.0	30	19.6
MODERATE	1,952	60.6	101	66.0
LOW	916	28.4	22	14.4
TOTAL	3,223	100	153	100

Source: Jennings *et al.*, 1995, and Jennings, 1997.

As a result of the functional literacy survey, a National Functional Literacy Committee has been established. Among its goals are:

- to elaborate and promote a national literacy programme which encompasses all literacy-related work of government, non-government and private sector institutions and individuals;
- to develop, adapt and disseminate literacy training materials throughout Guyana;
- to ensure that by the end of the primary stage all students would have at least achieved functional literacy.



## Teaching staff

The Cyril Potter College of Education (CPCE) offers several teacher training programmes:

### *Nursery Programme*

This can either be done on a pre-service basis on the main college compound in Georgetown or on a in-service basis in the regions. The in-service programme is also offered in Georgetown. The programme is of two years' duration.

### *Primary Programme*

This follows a pattern of delivery similar to that for nursery education. The two-year programme is designed for primary school teachers who are generalists (i.e. they should be able to teach all the areas that make up the primary school curriculum).

### *Secondary Programme*

This programme is of three years' duration and can be done on a pre- or in-service basis. Two options are offered: pre-vocational (home economics, agriculture, industrial arts) and academic (language arts, mathematics, social studies, science, art and music).

Persons with a trained teacher's certificate from CPCE, and at least two years' experience post-certification, are eligible for admission into the certificate in education programme in the faculty of education, University of Guyana. Here they can specialize in nursery, primary or secondary education. Options in the latter are offered in mathematics, science, social studies, English, Spanish, home economics and agricultural science. These specializations are offered in the Bachelor of Education (B.Ed.) programme; admission is dependent on successful completion of the two-year certificate in education course. The B.Ed. requires a further two years to complete.

The full four-year programme on a part-time basis which culminates in the award of the B.Ed. offers candidates a solid grounding in the foundations of education. This includes courses in the philosophy of education, issues related to education and development in developing countries, the psychology of learning and teaching, curriculum theory and development, classroom testing and measurement and research methods.

The nursery education programme gives candidates a thorough grounding in the nursery school curriculum, the history and philosophy of early childhood education, the social background of the nursery school child, school/parent and community interaction and creative arts for the nursery school. The programme also includes courses in administration for those who have responsibility for the management of nursery schools.



The primary education programme provides opportunities for candidates to focus either on classroom teaching or administration. Courses are offered in the teaching of language arts, social studies, science and mathematics at the primary level, as well as educational technology, sociological theory and fundamentals of school administration.

In the secondary education programme a number of the content courses in the area of specialization (e.g. English, mathematics) are the same as those offered to candidates for Bachelor of Arts or Science degrees in other faculties. In the faculty of education, the candidates are given courses which deal more with the methodology and practice of teaching. All the programmes have a practicum that involves the assessment of the candidate teaching in the classroom or performing the function of an administrator or supervisor. In addition, in all the programmes the candidates are required to undertake a research study. This either takes the form of the development and implementation of some curriculum materials, or an investigation into a significant problem in education in Guyana.

The Diploma in Education (Dip. Ed.) is a two-year in-service programme designed to prepare candidates with a first degree (B.A., B.Sc., B.Ed.) to teach in the upper levels of the secondary school, especially at the sixth-form level. Specializations are offered in administration and the subject areas (mainly social studies, science, mathematics and English).

The B.Ed. in nursery education is a relatively new offering, as the first graduates of this programme entered the system in 1995. These persons are usually the heads of nursery schools or they have responsibility for supervising nursery school teachers at the regional level.

Persons with a trained teacher certificate specializing in primary education are qualified to teach in primary schools. Those with degrees in primary education are either heads of schools or function in some senior capacity (e.g. deputy head or senior master/mistress). Because of the severe shortage of teachers in Guyana, it is common practice to find a teacher at a higher level of education than that for which he/she has been trained. It is not unusual, therefore, to find persons who have been trained to teach at the primary level actually teaching in the lower forms of secondary schools. The secondary programme at CPCE prepares the teacher to teach in the lower forms of secondary schools, but many can be found teaching in the upper forms because there are very few Dip. Ed. graduates who remain in teaching, because the salary and working conditions are so unattractive. Many of the teachers trained in Guyana find jobs in the islands in the Caribbean where they can earn much better salaries. There are schools in St. Lucia, for example, that are staffed almost wholly by Guyanese teachers. The places left by teachers who have migrated have been filled by untrained and unqualified teachers. Whereas the expectation is that a teacher should have passed some subjects at the CXCSEC examination, in many rural schools, in particular, one finds teachers whose level of education has not gone beyond the community high school or the secondary department of the primary school.

## Teachers in school types by level of training (1990-93)

		1990		1991		1992		1993	
		No.	%	No.	%	No.	%	No.	%
<b>NURSERY</b>	: untrained	617	54	807	56	924	60	829	59
	:Trained non-graduate	501	44	614	43	595	39	541	38
	: Graduate	31	3	15	1	15	1	46	3
	TOTAL	1,149		1,436		1,534		1,416	
<b>PRIMARY</b>	untrained	1,285	34	1,530	42	1,651	45	1,542	45
	:Trained non-graduate	2,089	55	2,037	56	1,928	53	1,835	53
	:Graduate	440	12	75	2	63	2	76	2
	TOTAL	3,814		3,642		3,642		3,453	
<b>COMMUNITY HIGH SCHOOLS</b>	:untrained	176	39	226	41	247	47	237	42
	:Trained non-graduate	210	47	288	52	247	47	281	50
	:Graduate	63	14	36	7	35	7	47	8
	TOTAL	449		550		529		565	
<b>GENERAL SECONDARY</b>	untrained	435	37	560	41	503	39	497	39
	Trained non-graduate	532	45	605	44	617	48	628	50
	:Graduate	208	18	197	14	172	13	138	11
	TOTAL	1,175		1,362		1,292		1,263	

Source: Education Planning Unit, MOECD, 1995.



### Teachers in school types by level of training 1994-95

	GRADUATE				QUALIFIED				Unqualified	Total			
	Trained		Untrained		Trained		#Untrained			M	F	T	
	M	F	M	F	M	F	M	F					
Nursery	-	-	-	10	570	1	304	11	733	22	1,613	1,635	
*Primary	17	37	-	-	416	1,405	66	298	227	1,176	726	2,916	3,642
Community High School	5	9	1	1	81	116	14	27	35	130	136	283	419
General Secondary	13	24	6	7	265	370	56	65	190	257	530	723	1,253

Source: Education Planning Unit, MOECD, 1996. (\*) Includes secondary departments.

# These are teachers who have the requirements for entering the College of Education, i.e. a minimum of four GCE O-Levels or four CXC subjects at general proficiency levels 1, 2, 3 or basic proficiency grade 1.

Certain trends are apparent from the tables above:

- (1) Nursery and primary schools have the largest percentage of untrained teachers and the smallest percentage of graduates. Note, however, that graduates of the B.Ed. (Primary Education) programme have clearly begun to filter into the system in 1994-95. Data for 1996 should reflect a similar trend for graduates of the B.Ed (Nursery Education) programme.
- (2) General secondary schools attract the largest number of graduate teachers but even here their numbers seem to be in decline.
- (3) The teaching profession is made up largely of persons with the trained teachers certificate from the CPCE. These are in the majority even in the general secondary schools where students are being prepared for CXCSEC. Ideally, these students should be taught by graduates with the diploma in education.
- (4) The largest percentage of unqualified teachers (i.e. those who do not have the qualifications necessary for entering the Teacher College) are to be found in nursery (46%), primary schools (39%) and community high schools (39%). It is also alarming that 36% of the teachers in general secondary schools (which are regarded as the top schools in the country) are unqualified.
- (5) Teaching is dominated by women, who far outnumber men in all school types.

In-service training of teachers has largely been the responsibility of the National Centre for Educational Resource Development (NCERD) which was established as an arm of the Ministry of Education in 1988. Included in the aims of the Centre are:

- to develop processes designed to improve teaching methodologies and administration in the education sector;
- to introduce new or different teaching strategies and technological innovations, where feasible, into the learning environment;
- to provide continuous in-service training for teacher educators and supervisors, and plan the annual activities of in-service teacher education.



Between 1988 and 1991, NCERD held annual workshops for all primary and community high school teachers throughout the country. This involved a team of persons from the Centre travelling around the country to hold the workshops at selected central sites. These workshops targeted the principals of the schools, with the understanding that on return to their schools they would in turn train their own teachers in the new ideas and methodologies learnt. Training workshops were also held in the specialist subject areas but these tended to be on an *ad hoc* basis. Training programmes include areas such as principles of teaching, curriculum planning and development, the reinforcement of language and mathematical skills across the curriculum.

Since 1991, the workshops have continued although not on such a regular basis. The general pattern is for selected teachers to attend workshops on the NCERD location in Georgetown and then for these teachers in turn to return to their schools and pass on what they have learnt to their colleagues. The current thrust is on training teachers to develop reading skills with a view to addressing the problem in literacy discussed earlier.

### Salary scale (per month)

Below G\$ 12,000.00	
G\$ 12,000.00 -	G\$ 14,999.00
G\$ 15,000.00 -	G\$ 19,999.00
G\$ 20,000.00 -	G\$ 29,999.00
G\$ 30,000.00 -	G\$ 35,000.00
over G\$ 35,000.00	

Source: Education Planning Unit, MOECD, 1995.

As can be seen from the table above, teachers' salaries in Guyana are very low, ranging from below G\$12,000 for unqualified teachers to over G\$35,000 paid to principals of certain schools. At an exchange rate of G\$144 to US\$1, a principal of a school earns about US\$250 per month. The fact that many teachers leave the country to take up jobs in schools in the Caribbean islands is not surprising, as in those countries they can earn about US\$1,500 per month.

Working conditions are poor and benefits are few. For example, teachers are not given any assistance with housing, although homes and rentals are very costly in Guyana, especially in the capital city and towns. Teachers are given monetary incentives for teaching in schools in the hinterland. Although they are normally provided with accommodation, the conditions are so rough that most teachers shy away from working in those areas. The main disincentives are: the isolation of the area; difficulties with transportation and getting water, especially in the dry season; and the high cost of purchasing food items.

The creation of the post-senior assistant master/mistress—and its addition to that of senior master/mistress—has widened the scope for promotion in the system. Apart from principals and deputy principals, there are also headships of departments



to which teachers can aspire. Studying for degrees and diplomas and participating in professional development courses increases the teachers' prospects for promotion. In-service training is also important, and heads of schools are expected to organize staff development programmes with the support of NCERD staff, if necessary. Well-managed staff development programmes can serve as important sources of professional support during employment. Educational projects which are funded by international agencies usually have a component for the professional development of staff. This is normally done through training abroad.

The faculty of education offers a Bachelor's degree programme in primary and nursery administration which is especially suited for the training of heads of nursery and primary schools. The Diploma in educational administration is especially suited for secondary school principals and heads of departments.

The Master's in education programme—which includes specialization in the management of education and in curriculum development, curriculum change and evaluation—is especially suited for the training of senior officers in the Ministry of Education and senior school administrators. Options are also available for persons in senior positions with responsibilities in measurement and evaluation, guidance and counselling and language teaching in Creole contexts.

## **Educational research and information**

Most research on education is undertaken at the University of Guyana, where it is part of the contractual agreement of full-time staff to conduct research that promotes the development of their subject specialization. As there are 212 full-time staff members at the University, theoretically this is the number that should be involved in research. However, not all staff members are productive and they complain frequently about the constraints on research, such as the lack of funding, inadequate facilities, materials and equipment. From time to time some funds are made available for research by funding agencies such as the UNDP, but these are limited and not sustained.

Research on education is also done in the Education Planning Unit at the MOECD, but this is largely in the area of compiling education statistics. Interestingly, the Unit used to be known as the Research and Planning Unit, but lack of resources (human and financial) for research over the years has led to the change of name.

At the faculty of education, University of Guyana, the main fields of research are: educational administration, measurement and evaluation, curriculum development and change, language and literacy. A few studies at the master's degree level have also been accomplished in the areas of science, social studies, geography and mathematics.

These research studies have mainly been of use to the researchers themselves, many of whom hold senior positions in the Ministry of Education or education institutions. Because of their highly academic orientation, the findings have not been disseminated, since the researchers do not take the trouble to re-write the work in a language which would make it more accessible to the public, and particularly to policy makers. These studies have to be consulted in libraries. The faculty of



education attempted to address this problem by producing the journal *Education and research in the Caribbean* (ERICA) through which some of the research done was disseminated. However, the journal suffers from a lack of funds.

A policy study commissioned by the MOECD—*Functional literacy survey of out-of-school youth*—has been given much publicity in the media and the information has obviously been used by a wide cross-section of the population. This is evidenced by the number of persons/groups that have become involved in literacy projects.

On the whole, one would say that, judging by the limited resources allocations, educational research is not regarded as priority in Guyana and its importance is recognized by few individuals, institutions and organizations. It is still, in many respects, viewed as a luxury which a developing country can ill support from local resources. One consequence of this, however, is that when international funding agencies such as the World Bank require justification for investing in education, the research evidence on which such justification invariably is founded is lacking. Such 'research' is usually then carried out by foreign consultants who spend very brief periods in the country and end up with reports and recommendations that lack an internal understanding of the situation and the cultural differences in the country.

Another problem in research relates to the accuracy of statistical information on the education system, because of the apparent absence of 'checks and balances' at the source of the information in schools, colleges, etc. Some of the institutions visited by the author while collecting data for this report had their enrolment and other data written in pencil in a school exercise book, and nobody had taken the trouble to collate the data for years. In fact, a frequent complaint heard from the Ministry of Education is that it has a wealth of data about schools that needs analysis. NCERD, for example, has masses of data on school examinations which have not been analyzed. The situation may be changing because the Examinations Division of the Ministry of Education and the Curriculum Development and Implementation Unit at NCERD did an analysis of the 1996 CXC general proficiency results for secondary schools in Guyana. It is expected that this will be an annual undertaking. There is, however, little attempt to disseminate the information to the public.

Apart from the relative lack of dissemination of the findings of research, other bottlenecks to research include: the scarcity of trained researchers; the perception of educational research as an ancillary activity; and the inadequacies of support services, such as libraries and local bookshops. Access to Internet services, which was made available to consumers in Guyana in 1997, may help to make international information in education research more readily available. However, the services are costly and beyond the resources of the typical university researcher or those employed in the Ministry of Education.



## References

- Anthony, K.D. *Summary indicating main findings of research and report on aspects of the level framework of education in the commonwealth Caribbean*. Georgetown, CARICOM Secretariat, 1993.
- Bernard, D. et al. *National report on higher education in the Republic of Guyana*. UNAMAZ/UNESCO, Georgetown, September 2002.
- Bernard, M. Innovations in Science teaching in Caribbean schools with special reference to school based assessment. *Journal of Education and Development in the Caribbean*.
- Craig, D. R. Society, economy and the university. The case of Guyana. *ACU Bulletin of Current documentation*. London, Association of Commonwealth Universities, 1993.
- Craig, D. R. *The University of Guyana: A development plan*. Georgetown, 1993.
- Caribbean Examinations Council. *CXC and the candidate*. Bridgetown, CXC Head Office, 1991.
- Jennings, Z.; Kellman, W.; Clarke, C.; Joseph, V. *Functional literacy survey of out-of-school youth*. Georgetown, University of Guyana, 1995.
- Jennings, Z. *The education system in Guyana*. Document prepared for the International Bureau of Education. Georgetown, Education and Development Services, October 1997.
- Jennings, Z. *Nipped in the bud: young Guyanese adults and their functional literacy*. Georgetown, Education and Development Services.
- Kellman, W.; Bernard, M.; McKenzie, J. The predictive validity and usefulness of NFFAT. *Education and research in the Caribbean*, vol. 1, no. 2, 1995, p. 122-26.
- Ministry of Education. *National Report of Guyana*. International Conference on Education, 47<sup>th</sup> session, Geneva, 2004.
- Ministry of Education and Cultural Development. *Education policy and five-year development plan for Guyana*. Georgetown, 1995.
- O'Toole, B. One response to the challenge of special education in the 1990s. *International journal of special education*, vol. 4, no. 2, 1989, p. 129-140.
- Paul, U.M.; Hamilton, E.M.; Williams, R.A. Participation of local communities in the financing of education in Guyana. *Prospects*, vol. XV, no. 3, 1986, p. 377-87.



Paul, U.M.; Bernard, M.; Dash, R.; Hamilton, E. Guyana. In: Bray, M. ed. *Ministries of Education in Small States: case studies of organization and management*. London, Commonwealth Secretariat, 1991.

Planning Unit. *Digest of educational statistics of Guyana in 1994-1995*. Georgetown, Ministry of Education and Cultural Development, 1996.

United Nations Development Programme (UNDP). *Human development report*. New York, Oxford University Press, 1995.

Williams, E. *Secondary education and change in the community high school programme*. Paper presented at Senior Officers Retreat, Ministry of Education and Cultural Development, Guyana, May 5-7, 1993.

World Bank. *Caribbean region: access, quality and efficiency in education*. Washington D.C., The World Bank, 1993.

## Web resources

Ministry of Education: <http://www.sdn.org.gy/minedu/> [In English. Last checked: October 2007.]

For updated links, consult the Web page of the International Bureau of Education of UNESCO: <http://www.ibe.unesco.org/links.htm>