



Cyprus

Updated version, April 2007.

For more detailed and updated information consult: <http://www.eurydice.org>

Principles and general objectives of education

The general aim of education in Cyprus is the development of free and democratic citizens, with fully developed personalities, mentally and morally refined, healthy, active and creative, who will contribute with their work and their activities to the social, scientific, economic and cultural progress of the country and to the promotion of the co-operation, mutual understanding, respect and love among individuals and peoples for the prevalence of freedom, justice and peace.

Education helps the new generation to: assimilate the spiritual and other achievements, as well as the fruitful elements of the past; capitalize on all the possibilities of the present; and proceed to new achievements in all sectors of social activity.

The objectives of education are: the fulfillment of the island's social, economic, cultural and other needs; the provision of specialized education, after a common general education, for both vertical and horizontal mobility; the preparation of young people for a profession and lifelong education; the strengthening of Cyprus as an independent State; the promotion of equal educational opportunities; and the promotion of friendship and co-operation between the various communities of the country.

Current educational priorities and concerns

In general, the rating of education in Cyprus, both in quantity and in quality, is comparable to that of more developed countries. This development has progressed under the influence of the internationally accepted principle that education is not only a basic human right, but also a significant productive investment in humanity. Furthermore, there has been more demand for pre-primary, secondary and tertiary education, due to an increase in the number of students. The only exception is primary education, where the number of pupils decreased by 0.5% due to the decrease in the number of births for that age bracket. An important development in the education sector has been the establishment of the University of Cyprus on the basis of Law 144 of July 1989, with which the completion of the education system has been achieved.

The priorities for education in Cyprus are: promoting respect for the dignity and uniqueness of each individual and for the opinion of the majority; encouraging cooperation, responsibility, participation in decision-making, and equality of opportunity in all aspects of school life; upgrading the quality of education; combating intolerance and xenophobia; preparing pupils for the world of work; choosing and training the teachers and administrators of the system efficiently; re-organizing and updating the education system; developing activities for lifelong



learning; developing research and technology; and comparing, relating and accrediting vocational and academic qualifications.

In recent years, educational innovations mainly focus on content, teaching materials and methods of evaluation, and were intended to make the education system more effective, flexible and dynamic. More specifically, the principles of the educational process are: the free flow of students from one level of education to the next (with the exception of tertiary education); the creation of comprehensive schools to cater to all the pupils coming from an area, irrespective of abilities and aptitudes; co-education; the horizontal transfer of students from one course to another; and the emphasis on general education as a means of providing a common culture, maintaining the coherence of society, and offering the basic skills, knowledge and understanding required for specialization.

The Five-year Development Plan 1994-1998 addressed several problems and gave special attention to the expansion of pre-primary education, with the gradual entrance of children over 3 years of age and the entrance of all children aged 4½-5½. It also focused on the qualitative development of the public sector. Proper measures were taken to ensure that pre-primary education would be mainly offered by the state, and support to such services by the communities. Nevertheless, the government maintained its inspection, regulating and monitoring roles, and offered services and incentives where the private and community sectors, especially in rural areas, were lacking.

In addition, the Plan provided a common legislative framework for the institutions (i.e. staff qualifications, work schedule, content of services) and introduced a coordinating committee for the definition of a common policy at the pre-primary level. It promoted a system by which boarding fees are imposed on a common basis according to income criteria and parameters established by the government's social policy. It created multigrade classes where the number of children is not sufficient to form peer-groups according to age, as in rural communities. Finally, it transferred the operation of government day-care centres from the Welfare Services to the communities. The Five-year Plan also focused on the qualitative improvement of primary education.

The unification of primary education with the gymnasium was established on a systematic basis, so that a system of nine-year basic education could be developed, providing the students with the necessary qualifications to continue their education or become productive members of society. Under these circumstances, a unified curriculum was applied, teaching materials were produced, and teaching staff were trained accordingly. The division of primary education into lower and upper cycles has been phased out.

The Ministry of Education and Culture is proceeding into the twenty-first century in a context that is offering an opportunity for important innovations in education. Such innovations are expected to provide solutions to mentioned problems and to upgrade education, in general. The basic goals are:

- To offer flexible, multifaceted programmes, which combine general education enriched, to a certain extent, with elements of technology education to satisfy



the needs of contemporary citizens, offering to them the opportunity for lifelong education, through the development of the necessary intellectual skills (critical analysis, ability of data management and use) and in a way of limiting their “mechanization” and generally the encouragement for the acquisition of new knowledge.

- To offer equal educational opportunities to everybody, according to ability, in such a way that exception and prohibition will be non-existent. Moreover, the needs of children with special needs and functional illiteracy are faced effectively.
- To modernize education in order to successfully respond to international challenges affecting drastically its content, such as the creation of the society of information, the upheaval of knowledge, the progress in technology and science, and the globalization of economy.
- To serve to the general goals of the country, such as the accession to the European Union (E.U.), the upgrading of its role, as an international and peripheral educational centre and a centre of information, and the needs in the job market.

The accession of Cyprus to the E.U. in May 2004 creates multiple implications for the education system and for primary education in particular. The Department of Primary Education is called to respond to, and fully adopt the, obligations deriving from the full accession of Cyprus to the E.U. The process of embracing the European Directives, policies and principles is complicated and engages multiple authorities, services, organizations and associations from various fields.

Primary education has been going through important transformations in recent years, especially because of socio-cultural changes that have been taking place. Many children from foreign countries have been enrolling in primary schools in Cyprus over the last few years, calling for a dynamic response from the Ministry of Education and Culture. Consequently, the Department of Primary Education has taken up the responsibility of facilitating and supporting children with different cultural identities to manage their smooth integration and adjustment into a creative environment. Within the context of providing an intercultural education, the Ministry offers special educational programmes to both Cypriot children who return to Cyprus after living abroad and children of foreigners whose parents work in the country. Moreover, the Ministry has published special books for teaching the Greek language as a second or foreign language to these students. Additional supporting periods are furthermore allowed to teachers for supporting students with literacy and learning problems and for effectively teaching Greek as a second language. Special emphasis is also given to the in-service training of the teaching staff so as to enable teachers to deal effectively with the specialized needs of these students.

In April 2004, the Council of Ministers approved the free and compulsory pre-primary education scheme for children aged 4 years and 8 months to 5 years and 8 months. This reform is basically driven by social and educational purposes, since it responds to the need for ensuring the children’s safety and for enabling parents to balance family and work responsibilities. Additionally, the reform contributes



significantly to the upgrading of the quality of primary education, since children are inducted in the educational environment early; therefore the foundations for an all-round education and personality are strengthened.

Laws and other basic regulations concerning education

Public primary and secondary education are both free and compulsory. The law concerning compulsory education was introduced in 1962, but in practice primary education has been universal since 1945. According to **Law 12/1965**, pre-primary, primary, secondary, and some sections of post-secondary education are under the authority of the Ministry of Education. According to the **Education Acts on Elementary Education**, primary school means a state school financed and administered by the government, which provides six years of compulsory education to children from 5 years and 8 months of age.

According to the **47/79 Law on Special Education**, the government has undertaken responsibility for the education of children with special needs between the ages of 5 and 18 years. This Law has been replaced by the **Law 113 of 1999** on Education and Training of Children with Special Needs (age group 3-18 years), the **Regulations 185 of 2001** regarding the mechanisms for early detection of children with special needs, and the **Regulations 186 of 2001** regarding education and training of children with special needs which support the application of the Law.

The University of Cyprus was set up by **Law 144** of July 1989. The law which concerns the establishment of the Cyprus University of Technology was approved on 18 December 2003.

Private schools operate according to the **Private Schools Laws** of 1971. The establishment and operation of private tertiary-level institutions are regulated by the **Laws 67(I)/1996** and **221(I)/2004**, which also concern the establishment of the Council for Educational Evaluation and Accreditation (SEKAP).

During the Five-year Development Plan, the full implementation of the **1/87 Act** have been promoted, setting the basis for the sound development of private tertiary institutions by means of their registration with the Ministry of Education, their educational evaluation and accreditation, as well as their inspection by the Ministry of Education and Culture.

Almost all aspects of primary education are covered by the **Regulations 223 of 1997** concerning the functioning of public primary schools.

According to the new **legislation of 1 September 2004**, children aged 4 years and 8 months to 5 years and 8 months are obliged to attend either public or private kindergartens that are registered and approved by the Ministry of Education and Culture.

The **Law 109 (1)** of 29 July 2005 regulates the establishment, operation and control of private universities.

Administration and management of the education system

Educational administration is centralized. Pre-primary, primary, secondary and some sections of post-secondary education are, according to Law 12/1965, under the authority of the **Ministry of Education and Culture**, the highest authority in educational policy-making being the Council of Ministers. The Ministry is responsible for the administration of education, the enforcement of education laws and, in cooperation with the Office of the Attorney General, the preparation of education bills. The bills are tabled for debate and approval by the House of Representatives.

Curricula for pre-primary, primary, secondary general, technical schools and the Pedagogical Academy are prescribed by the Ministry of Education and developed on the basis of suggestions made by teachers, inspectors and school boards. Post-secondary technical and vocational curricula are drawn by the relevant Ministry on the advice of the **Board of Governors** or **Specialist Committees**. The curricula for private schools of all levels are developed according to the needs of various sectors of the wider public. Established in 1972, the **Pedagogical Institute** under the Ministry of Education is responsible for pre-service and in-service teacher training, educational research and evaluation, educational documentation, and curriculum development. Its Curriculum Development Unit produces textbooks for primary and secondary schools.

Appointments, secondments, transfers, promotions and discipline of the teaching personnel and the inspectorate are the responsibility of the **Education Service Commission**, a five-member body appointed by the President of the Republic for a period of six years.

The construction of school buildings is under the responsibility of the **Technical Services** (a section of the Ministry of Education), while their maintenance and equipment are the responsibility of **School Boards** under the supervision of the Technical Services. In urban areas these Boards are appointed by the Council of Ministers, while in rural areas since 1979 they are elected by the communities. Each year the School Boards submit their budget for the next school year to the Ministry of Education for approval. At the end of each school year, they submit a detailed financial statement to the Ministry of Education which is audited by the State Auditors.

The **Cyprus Council for the Recognition of Higher Education Qualifications (KYSATS)** is an independent body in charge of the recognition of qualifications awarded by higher education institutions. The **Council for Educational Evaluation and Accreditation (SEKAP)** is another independent body that advises the Ministry on issues concerning the establishment, monitoring and operation of private tertiary-level education institutions. The **Advisory Committee of Tertiary Education** deals with matters concerning the establishment of public and private institutions, registration of new programmes of study and tertiary-level education policies. The **Secondary Technical and Vocational Education Advisory Board** deals with issues concerning technical and vocational education.

Besides the Ministry of Education and Culture, three other Ministries, namely the **Ministry of Labour and Social Insurance**, the **Ministry of Agriculture and**

Natural Resources and the **Ministry of Health**, play a role in education by administering some vocational and post-secondary institutions pertinent to their functions, such as the Higher Technical Institute, the Hotel and Catering Institute, the Forestry College, the School of Nursing and the Mediterranean Institute of Management.

Overall planning is done by the **Planning Bureau**, an independent authority of the Republic. Similar planning is done by all the Ministries which offer post-secondary, specialized education. Their development policies, however, are first submitted to the Planning Bureau, which then forwards them to the Council of Ministers together with its comments.

The Ministry of Education is advised on its policies by the **Education Council**, a widely representative body consisting of representatives of the Planning Bureau, the Director General of the Ministry of Labour and Social Insurance, representatives of the Church, the parliamentary Committee of Education, parents' associations, teachers' unions, and seven persons well-known for their keen interest in educational matters.

Primary and lower secondary education is compulsory up to the age of 15; public primary and secondary education are free. Since 2004/05, one year of pre-primary education is also free and compulsory in public establishments.

Structure and organization of the education system

Cyprus: structure of the education system

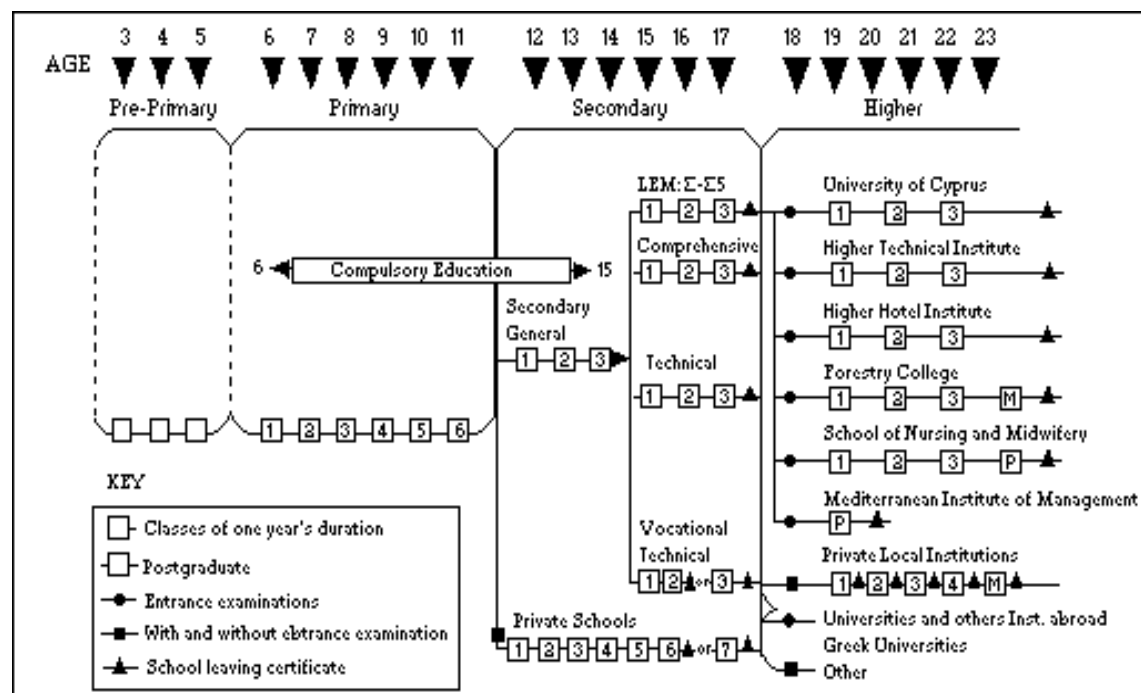

Note: LEM: Stands for Lyseums of Optional Subjects



Pre-school education

Starting from 2004/05, pre-primary education is compulsory for children aged 4 years and 8 months to 5 years and 8 months. Younger children aged 3 years to 4 years and 8 months may enroll in public kindergartens on a fee-paying basis provided that there are vacant places.

Primary education

Primary education provides a six-year course to children from the age of 5 years and 8 months. Primary education is free and compulsory. The six-year course is divided into six grades. Schools use the same curriculum, but the teachers are allowed to adapt it to the needs of the local economic and cultural environment. At the end of Grade VI, pupils receive a certificate. No written examinations are given at any level.

Secondary education

Public general secondary education extends over six years and is divided into two cycles: the lower or *gymnasio* (age group 12–15) and the upper or *lykeio* (age group 15–18). After the compulsory lower secondary education cycle, students usually enter the comprehensive upper secondary school (*Eniaio Lykeio*), a new type of lyceum implemented since 2000/01 phasing out the LEM (*Lykeio* of Specialized Studies), or technical and vocational schools (theoretical or practical streams, both lasting three years). Students who pass the final examination at the end of secondary education are awarded a school-leaving certificate, granting access to tertiary and higher education.

Tertiary and higher education institutions include the University of Cyprus, the Open University (which in September 2006 started to offer two programmes), the Cyprus University of Technology (starting to operate in 2007), public tertiary-level institutions offering professionally-oriented programmes (technical engineering, forestry, hotel and catering, nursing), and a number of private higher education institutions. Programmes lasting one to three years lead to the award of a certificate (one-year course), a diploma (two-year course) or a higher diploma (three-year course). The University of Cyprus offers undergraduate programmes in a variety of fields. A Bachelor's degree requires four years of study. Full-time master's degree programmes normally require one to two years of study. The University of Cyprus also offers postgraduate programmes leading to a doctoral degree after three to eight years of study, including research training.

The school year consists of approximately 180 working days; classes are held from 10 September until 31 May. The academic year consists of thirty weeks, divided into two semesters (September-January and January-May).

The financing of education

Public education is mainly financed by the government directly or through local authorities or school boards, while private education is supported by individuals and private organizations. In the case of private foreign language schools, they are assisted by overseas authorities and organizations. The University of Cyprus is financed by the state.

Public and community pre-primary education is supervised and financed by the government. Private kindergartens are run on a profit basis by individuals who must be qualified in child care.

The government provides the means for the public primary schools and awards annual grants to local authorities to undertake their responsibilities. In the public sector, financing covers every educational need, including the free provision of textbooks. In the case of general secondary education, financial provisions are the responsibility of the government either directly or through the School Boards (by awarding grants to them). Financing of technical and vocational secondary schools is also the direct responsibility of the government. Public tertiary institutions are financed in various ways as they come under various ministries but essentially all their costs are covered by the public budget. Funds for public universities are provided by the Ministry of Education and Culture through the approval of their budget proposals which are examined and approved by the Ministry of Finance, the Council of Ministers and the House of Representatives. Tuition fees represent a major source of funding for the private institutions. Nominally the University of Cyprus charges fees but the amount of grants awarded by the state is so extensive that no student pays any fees except in very extreme cases (e.g. failure in academic achievement).

As far as public, non-formal education is concerned, fees are charged for some of the classes; they are paid into the State revenue. The Government covers the expenditure, which normally exceeds revenue. In addition, it offers a number of scholarships to outstanding pupils (10% of enrolment in the case of foreign languages) at the twenty-eight State Institutes of Further Education.

In 1996, the cost of education in both public and private sectors was CP289.9 million or 7% of the gross national product (GNP). The cost for the public sector was CP192.5 million or 4.6% of the GNP. In 1993, this overall cost was CP210.1 million or 6.3% of the GNP, and the public cost was CP139.1 or 4.3% of the GNP. In 1999 public expenditure on education as part of the GDP and the national budget was estimated at 5.7% and 15.3% respectively (6.4% and 14.6% respectively in 2002).

The lack of adequate financial resources that are necessary to implement the policies of the Ministry of Education and the desirable innovations is an important obstacle to the continuous improvement of the quality of education. Although open education for all is among the top priorities of the government, this is to some extent inadequately financed, especially during times that cost-cutting measures are enforced.

The educational process

In order to develop the curriculum, the Ministry cooperates with teachers' unions, parents' associations and the Pedagogical Institute.

The new curriculum places emphasis on: (i) respect for the dignity and uniqueness of each individual by individualizing instruction; (ii) respect for the opinion of the majority; (iii) creation of opportunities for democratic participation in the decision-making process concerning education; (iv) encouragement of cooperation and responsibility; and (v) equality of opportunity in all aspects of social life.

In the new curriculum, the teacher has ceased to be the dominant figure in the classroom, but rather, has become the organizer of educational activities in cooperation with the pupils. The emphasis is not on whole-class teaching but on a variety of group and individual activities. Independent study, experimentation and the development of creative skills are promoted.

Indeed, children are encouraged to participate in all aspects of school life. It is believed that through this participation, responsibility, self-esteem, self-dependence and creativity are developed, and real learning is achieved. In order to pursue this objective, committees and work-groups are formed at the classroom level; at the school level, a pupils' council has been formed. The new curriculum makes extensive reference to the affective domain, underlining the importance of values, interests and attitudes for the developing personality of the child.

Teachers are encouraged to avoid compartmentalizing subjects and to integrate their activities, concentrating on the facts that are of real interest to the children, rather than on certain topics prescribed by textbooks or syllabi.

The steady decrease of the pupil/teacher ratio and the construction of new school rooms have enabled teachers to further individualize instruction and to offer more opportunities in remedial teaching. Evaluation consists of the child's self-evaluation and evaluation by the teacher on a systematic basis.

Since there is no 'fixed' or 'stable' curriculum that will always suit every school, teachers are encouraged to modify and adjust the curriculum according to their environment and to the particular needs of the children. Furthermore, departmental committees consisting of members of the Inspectorate, representatives of the Pedagogical Institute and the teachers' unions deal with the continuous development of the curriculum.

Unifying the services of the curricula development units, upgrading the Pedagogical Institute and strengthening the educational psychology unit are considered important measures for the qualitative improvement of education. There have also been efforts to ensure that there is cooperation between the curricula development units and the related work at the Pedagogical Institute, in order to avoid the duplication of production. In addition, strengthening the staff of the education psychology unit is considered an essential prerequisite in the quest of coping with problems of functional illiteracy, children with special needs, etc.



Pre-primary education

The aims of pre-primary education are: to help children to adapt themselves to the broader school environment and to become an integral part of society; and to secure, preserve and promote the all-round development of the child to the highest possible level, according to his/her level of maturity. Balance is sought among the psychomotor, affective and cognitive aspects, with special emphasis on affective and social education.

State kindergarten schools cater for approximately 64% of preschoolers of middle or low-income families. Admission criteria are based on yearly income and family status (working, single-parent or refugee families). Private kindergarten schools cater for children not accommodated in the government sector. In 2003, the gross enrolment ratio was estimated at 60%

Pre-primary education is considered as part of primary education; therefore, a considerable part of it falls under the same law and regulations as those governing primary education, excepting specific regulations governing the operation of community kindergartens and those of the private sector.

Public kindergartens are established by the Ministry of Education in collaboration with parents' associations and local authorities. The Ministry of Education appoints the teaching staff and subsidizes the equipment while parents' associations or local authorities have responsibility for the facilities and basic equipment. Community kindergartens are non-profit organizations that operate only in cases where the public kindergarten classes available do not meet the needs of all the children in the community. They are established and run by parents' associations or local authorities and are registered by the Ministry of Education. Private kindergartens are established and operated by individuals with the approval of the Ministry of Education. The different categories of pre-school establishments develop their educational programmes according to the officially approved curriculum.

The curriculum is characterized as child-centered and problem solving-centered. This means that the attainment of objectives is sought through the encouragement of active participation in the learning process through problem-solving activities, experimentation and investigation in order to activate the critical and creative thought process. The daily programme of each kindergarten is a smooth succession of periods, but the order and duration of the activities is not fixed. The curriculum and timetable of each kindergarten is determined by the teacher, who must consider the needs, abilities and interests of the children, as well as the need for achieving balance between structure and freedom through a variety of challenging activities. The main parts of programme are the following:

- Free, low structured activities (80 minutes): a free choice of a variety of social, cooperative and creative activities such as art, role playing, experimenting, observation, basic reading, writing and mathematics.
- Group Activity A': (40 minutes) language, science, mathematics, health education, environment education, social education, and religion.
- Group Activity B': (40-80 minutes): story telling, theatre, music and movement, puppet shows, games, and poetry.



- Outdoor activities (40 minutes): physical educations, games, work in the garden, environmental observation.
- Quiet activities (40 minutes) in the final part of the school day: language, mathematics, individual or group work, which are structured and aim at developing necessary skills to facilitate the transition to the primary school.

In between these activities there are periods for tidying, washing, breakfast, snack and free playing (40 minutes). Integrated curricula rather than thematic approaches are widely used in most kindergartens.

As mentioned, starting from 2004/05 one year of pre-primary education in public establishments is free and compulsory for children aged 4 years and 8 months to 5 years and 8 months. According to national estimates, in 2003/04 there were 391 kindergartens (public, community and private) with 15,366 children and 878 teachers.

Primary education

Primary education is free and compulsory. The main evaluation procedure adopted is the continuous one. No written examination is given at any level. At the end of Grade VI, pupils receive a school-leaving certificate. All pupils proceed to secondary school without examinations. All schools are co-educational.

The all-day schools have been introduced to help improve the quality of education. In September 1999, the implementation of this new programme began in eight pilot schools; one year later, it was implemented in 24 schools (110 schools in 2003/04). Although the morning timetable remained uninfluenced, the afternoon programme included additional curriculum activities such as creative work in art, dancing, sports and computer studies. It also includes time for pupils to complete their homework and to receive individual help if necessary.

Schools operate in every town or village where there are more than 15 children. Area schools serve neighbouring communities with less than 15 pupils. Every school has its own school committee. In urban areas they are appointed by the government, while in rural areas they are elected by the communities. The six-year primary education is offered: in one-teacher schools (with a maximum pupil population of 25); two-teacher schools (with a pupil population of 26-50); three-, four- or five-teacher schools in which the maximum number of pupils per teacher is less than 34. Most of the large schools in urban centres are divided into two cycles: Cycle A (Grades I-III) and Cycle B (Grades IV-VI).

In urban areas and in large rural schools, single-grade classes have been adopted, while in small communities multigrade classes have been established. Schools with less than 24 pupils have one teacher and those with 26 to 50 pupils have two teachers. Teachers are allocated in such a way that in no case will any one teacher have responsibility for more than 34 pupils. In 2000/01, the gross enrolment rate for the primary level was estimated at 97%.

Schools use the same curriculum, but teachers are allowed to adapt it to the needs of the local economic and cultural environment. All subjects of public primary

schools are compulsory. The time allocated to each subject area is differentiated according to the type of school (one-teacher, two-teacher, etc., and schools of the lower cycle). The typical weekly lesson timetables in 2001 and 2004 (schools with six or more teachers) are shown below:

Primary education: weekly lesson timetable (2001)

Subject	Number of weekly periods in each grade					
	I	II	III	IV	V	VI
Greek language	13	13	14	13	10	10
Mathematics	5	5	6	6	6	6
Social studies	5	5	6	6	6	6
Science	–	–	2	2	2	2
Physical education	2	2	2	2	2	2
Art education	2	2	2	2	2	2
Music	2	2	2	2	2	2
Foreign language (English)	–	–	–	2	2	2
Home economics/Design and technology	2	2	–	–	2	2
Free activities	–	–	–	–	1	1
Total weekly periods	31	31	34	35	35	35

Source: Ministry of Education and Culture, 2001. Each teaching period lasts 40 minutes. Social studies in Grades I–II include science, geography, history and religious education; in Grades III–VI, social studies include history, geography and religious education, all taught separately.

Primary education: weekly lesson timetable (2004)

Subject	Number of weekly periods in each grade					
	I	II	III	IV	V	VI
Modern Greek language	14	14	14	13	10	10
Mathematics	7	7	7	6	6	6
Religious education	2	2	2	2	2	2
History	–	–	2	2	2	2
Geography	–	–	2	2	2	2
'Environmental studies'	3	3	–	–	–	–
Science	1	1	2	2	2	2
Physical education	2	2	2	2	2	2
Art education	2	2	2	2	2	2
Music	2	2	2	2	2	2
Foreign language (English)	–	–	–	2	2	2
Home economics/Design and technology	2	2	–	–	2	2
Free activities	–	–	–	–	1	1
Total weekly periods	35	35	35	35	35	35

Source: Ministry of Education and Culture, 2004. Each teaching period lasts 40 minutes.

The assessment of pupils is based on overall class participation, oral and written tests and the results of work done at school and at home. Although there is no standardized test to assess pupils' achievement, there is a descriptive assessment of pupils which allows teachers to provide pupils and their parents with information on the results of each pupil's efforts at school and abilities in each subject. At the end of each school

year pupils of Grades I through V are awarded a progress certificate; almost all primary school pupils automatically move to the next class. Sixth-year pupils receive a leaving certificate. A pupil must repeat a class only when the teacher, the respective school inspector, the child's parents and the educational psychologist agree that repeating a class is in the best interest of the child.

In 2003/04, according to national statistics there were 347 public and 25 private primary schools with 58,420 and 3,298 pupils respectively. In the same school year, 3,820 teachers served in public primary schools and 334 in the private ones.

Secondary education

The philosophy underlying public secondary education is two-fold: (i) the dissemination of knowledge with emphasis on general education and a gradual transition to specialization in order to prepare students for an academic, professional or business career; (ii) the development of a sound, morally refined personality in order to provide society with competent, democratic and law-abiding citizens.

Public general secondary education extends over six years. It is divided into two cycles: the lower, or *gymnasion*; and the upper or *lykeion*. In the first three-year cycle all pupils follow a uniform common course and all subjects are compulsory. The *gymnasion* offers general education and serves as an observation period, giving pupils enough time to form an opinion about themselves and their interests, and giving parents and teachers opportunities of further appraising the aptitudes and abilities of the children and advising them accordingly. The weekly timetable (2001 and 2004) is shown below:

Lower secondary education (gymnasium): weekly lesson timetable (2001)

Subject	Number of weekly periods in each form		
	I	II	III
Religious education	2	2	2
Modern Greek language	6	5	5
Greek language and literature	3	4	4
Mathematics	4	4	4
History	3	2	2
Civics	–	–	0.5
Vocational counselling	–	–	0.5
Geography	1	1	1
Physics (*)	3	4	4
English language	4	4	4
French language	–	–	2
Physical education	3	3	3
Art education	2	2	1
Music education	2	2	1
Home economics/Design & technology	3	3	2
Total weekly periods	36	36	36

Source: Ministry of Education and Culture, 2001. Each teaching period lasts 45 minutes. (*) Includes botany and zoology in Form I; physics, chemistry and human biology in Form II; and physics, chemistry and biology in Form III.

Lower secondary education (gymnasium): weekly lesson timetable (2004)

Subject	Number of weekly periods in each form		
	I	II	III
Religious education	2	2	2
Modern Greek language	5	5	5
Classical Greek	3	3.5	3.5
Mathematics	4	3	4
History	3	2	2
Civics	–	–	0.5
Vocational counselling	–	–	0.5
Geography	1	2	–
Physics	–	2	2
Chemistry	–	1	1
Natural studies	2	–	–
Biology	–	–	2
English language	3	3	3.5
French language	2	2	2
Physical education	3	3	3
Art education	2	2	1
Music education	2	2	1
Home economics	1.5	1	1
Design & technology	1.5	1	1
Computer studies	2	2	2
First aid	–	0.5	–
Total weekly periods	37	37	37

Source: Ministry of Education and Culture, 2004. Each teaching period lasts 45 minutes.

A significant development, introduced since September 1990, is the teaching of design and technology in gymnasia. This was brought about by adjusting the aims, the teaching methodology and the contents of the existing traditional subject of craftwork in schools. Programmes have been monitored and revised so as to bring the subject into line with the needs of modern society.

According to national statistics, in 2003/04 there were 68 public gymnasia in the government-controlled areas. These schools provided educational services to 28,854 students out of the total number of 52,221 students enrolled in secondary education.

Nearly all of the pupils having successfully completed Form III continue their studies in the higher cycle, either at general secondary or technical and vocational school. This has resulted in a tremendous increase in the range of pupils' aptitudes and consequently in the need for a broad differentiation of syllabi, methods of teaching, teaching materials as well as a redefinition of the role of the teacher. Indeed, in recent years secondary education follows a more flexible and diverse orientation, catering to individual inclinations, aptitudes and interests. Attendance is compulsory for the successful completion of graduation requirements. The content of education, in-service training of teachers and the general quality of education have assumed an importance greater than ever before. Within the framework of the efforts of the Department of Secondary Education to prepare pupils for life, computer science has



been introduced in all *lykeia*. Computer science is a compulsory subject in the first year of all the *lykeia* combinations.

Until the end of the 1990s, the second three-year secondary education cycle was offered in either the *Lykeion* of Optional Subjects (LEM) or in technical and vocational schools. At the LEM, introduced in 1981, there were three categories of subjects: core, compulsory subjects; specialization subjects; and supplementary subjects. Although the pupils were free, in principle, to choose any of the optional subjects, in practice there were five main combinations of subjects which include related groups of optional subjects (i.e. classical studies; physics and mathematics; economics; skills for office professions; and foreign languages and modern Greek).

In 2000/01 the comprehensive upper secondary school (*Eniaio Lykeio*), a new type of lyceum, replaced the LEM. This new institution is characterized by focusing on general education, including technological and economy education. The students have the flexibility to form their own timetable according to their interests and inclinations. In this they are assisted by the teachers of career guidance and counselling and the Committee for the assessment of the students' options. The A form is, for the students, the form of observation, guidance and orientation. In this form the students have the opportunity to take decisions about what they will do in the following forms and how they will form their future getting ready for higher studies or the world of work. In the B and C forms the students attend common core lessons which are considered indispensable. At the same time they have the opportunity to select those lessons of orientation which will help them in their preparation for their future career and those subjects of interest or enrichment which will satisfy or enhance their special interests and inclinations.

In the A form all the subjects are common core ones, which means that they are compulsory: this form gives to all the students the chance to acquire a general rich core of knowledge and a rich social and emotional background. In the B form students are obliged to attend 19 periods of common core subjects and compulsory foreign languages. In addition they must select three or four stream subjects (4 periods per week) and two or no subjects of special interest or/and enrichment of two periods per week. This option is made from lists of subjects which are offered to the students and which note likely restrictions or preconditions that the students must consider. In the C form students are obliged to attend 17 periods of common core subjects and compulsory foreign languages. In addition they are required to select four optional stream subjects (4 weekly periods) and one subject of special interest or enrichment of two periods per week. This option is made from lists of subjects which are offered to the pupils and which note likely restrictions or preconditions that the pupils must consider.

In 2003/04 the number of students attending 39 *lykeia* reached 23,367 and those attending five evening schools reached 839.

Some 20% of the total student population attends public secondary technical and vocational education (STVE). It is offered to students who have graduated from the gymnasium at the age of 15. A proposal for the reform, restructuring and modernization of the content and structure of secondary technical and vocational education (STVE) has been approved by the Council of Ministers and it is being



implemented as from September 2001. According to the new revised curriculum, STVE is offered in two streams, the theoretical and the practical. The duration of studies is three years in both cases. During their third year, the students of the practical stream spend a day per week working in industry and follow a practical training programme. The students of the Hotel and Catering specialty follow a special programme of practical training, which is being implemented in cooperation with the Human Resource Development Authority, the Cyprus Hotel Association and the employees' organized agencies. The first year of studies is common for the cluster in each stream. Students select a specialty offered in the cluster of their choice in the second year of their studies. STVE leaving certificates are equivalent to those of the lyceum and school leavers from technical schools can compete for places in tertiary education with lyceum graduates.

In addition, the Evening Technical School has been operating on the premises of the 'A' Technical School in Nicosia since September 1999. The study programmes offered at the Evening Technical School are equivalent to the STVE programmes, which are offered in the morning. The material taught for each cluster and specialty is the same as the material taught for the cluster/specialty of the morning classes, adapted, however, to the particular characteristics of the students who attend evening classes. The duration of studies ranges from 1 to 4 years, depending on the educational background of the students. Attendance is free and it leads to the acquisition of a leaving certificate, which is equivalent to that obtained from public six-year technical schools.

Assessing learning achievement nationwide

The introduction of a system that will set national education levels and the establishment of assessment infrastructure constitute an essential priority for the education system within the range of aims for continuous qualitative improvement of its services. The evaluation of the national education levels at set intervals will be the main source of feedback on the degree of the effectiveness the education system, and, in the long run, will contribute to the modernization and the operational improvement of the syllabi, beneficially influencing the work conducted in the classroom.

Higher education

As mentioned, tertiary and higher education institutions include the University of Cyprus, the Open University (which started to offer two programmes in September 2006), the Cyprus University of Technology (starting to operate in 2007), seven public tertiary-level institutions offering professionally-oriented programmes (technical engineering, forestry, hotel and catering, nursing), and a number of private higher education institutions. Programmes lasting one to three years lead to the award of a certificate (one-year course), a diploma (two-year course) or a higher diploma (three-year course). The University of Cyprus offers undergraduate programmes in a variety of fields. A Bachelor's degree requires four years of study. Full-time master's degree programmes normally require one to two years of study. The University of Cyprus also offers postgraduate programmes leading to a doctoral degree after three to eight years of study, including research training.



About 60% of all secondary school graduates continue their studies beyond secondary education. Of these, about 34% attend higher education institutions in Cyprus and the remaining 26% attend higher education institutions abroad. In the academic year 1994/95, there were 9,067 Cypriot students at tertiary institutions abroad distributed by country as follows: Greece, 39.9%; United Kingdom, 27.4%; United States of America, 20.2%; Germany, 2.6%; other countries, 9.9%. Foreign students in Cyprus mainly come from countries of the British Commonwealth and the Middle East. The distribution of students at tertiary education institutions is: 36.4% in public institutions and 63.6% in private institutions. In 1994/95, there were six public and twenty-one private higher education institutions in Cyprus, with a total of 7,765 students, including 1,434 (or 18.5%) overseas students.

The University of Cyprus was set up by Law No. 144 of 1989 and started to operate in September 1992. During its fourth year of operation the total number of students was 1,810. The University reached its full operational level in 1998. Since 1992, new departments have been established, and new legislation enhanced the smooth operation of the University. Furthermore, significant steps were taken towards the construction of the University campus.

Admission to the University is based on entrance examinations that are organized by the Ministry of Education. Successful students are eligible to enter either the University or Greek universities. The University is academically autonomous. The duration of studies is normally four years at the undergraduate level. The length of the academic year is thirty weeks, divided into two semesters (September-January and January-May). The languages of instruction are Greek and Turkish. The evaluation system is based on coursework, projects, and final exams for each semester. Students are expected to complete their programme of studies in eight semesters. Public universities are autonomous in their academic affairs, the management and control of the administrative and financial resources and of their property, as well as the elections or promotions of the academic and administrative staff.

The University of Cyprus is a public corporate body and its funds and resources consist mainly of grants from the government and donations, gifts and private grants (provided that the acceptance of these shall safeguard the independence of the University). The minimum qualifications for a lecturer of the University of Cyprus are a doctoral degree awarded by a recognized University and evidence of competence in university teaching and research.

Public tertiary-level education institutions function under the supervision of various Ministries and award their own diplomas. These institutions include:

- The Cyprus Forestry College, under the Ministry of Agriculture and Natural Resources, which offers a two-year diploma course, a six-month post-diploma course, and a short training course in Forestry.
- The Higher Technical Institute (H.T.I.), under the Ministry of Labour and Social Insurance, which offers courses in civil engineering, electrical engineering, mechanical engineering, marine engineering, and computer studies. The Institute also offers medical equipment courses lasting ten months. It is a Regional Training Centre and has been designated as a WHO



collaborating Centre for Training and Research in Management, Maintenance and Repair of Hospital and Medical Equipment. A full-time, one-year foundation course is offered when an adequate number of applicants satisfying the entrance requirements is reached. Its objective is to prepare students for entry to the first year of the diploma courses.

- The Higher Hotel Institute, under the Ministry of Labour and Social Insurance, which offers: a three-year higher diploma programme in hotel and catering (specialization in food and beverage and room division); a three-year higher diploma programme in culinary arts; a one-year certificate programme in front office; and a one-year certificate programme in housekeeping.
- The School of Nursing of the Ministry of Health offers basic courses lasting three years and three months in general nursing and psychiatric nursing (registered nurses), and a one-year post-diploma course in nursing administration, midwifery, intensive care and other specialized fields.
- The Mediterranean Institute of Management, under the Ministry of Labour and Social Insurance offers a post-graduate management diploma programme lasting eleven months which is repeated annually between September and July. The programme offers the possibility for specialization in general management, production management and marketing management.
- The Public Health Inspectors School functions under the Ministry of Health, and trains public health inspectors. Its medium of instruction is the English language. The school offers a three-year course which leads to the award of the Diploma of Public Health Inspector.
- The Tourist Guides School, under the Cyprus Tourism Organization, offers a one-year course which leads to the award of the Diploma of Tourist Guide. The language of instruction is Greek.
- The Cyprus Police Academy, under the Ministry of Justice and Public Order, offers a three-year course which leads to the award of the Diploma of Probationary Policeman. The language of instruction is Greek.

In addition, in 2004 there were at least 23 private tertiary-level education schools, colleges and institutes registered with the Ministry of Education and Culture and offering a wide range of programmes in a variety of specialties. The Council for Educational Evaluation and Accreditation (SEKAP) has the overall responsibility for organizing and overseeing the evaluation and accreditation process of programmes offered by private tertiary-level education institutions.

Special education

The government policy is to encourage and support the integration of children with special needs into the education system and provide them with the opportunity to grow and learn together with their peers. As from September 2001, the Ministry of Education and Culture has put into effect the Law and Regulations regarding children



with special needs. The Department of Primary Education has launched various programmes to meet the educational and other needs of primary school children during the school year 2003/04. More specifically, nine special schools catered for 427 pupils with serious needs, whereas individualized help was provided for 2,562 children attending mainstreamed primary classrooms and special units functioned in ordinary schools for 194 children with moderate needs. The needs of these children are satisfied by well-qualified teachers of various specialties (teachers for intellectual, emotional and other problems, the deaf, the blind, special gymnastics, music therapy, work therapy, speech therapy, educational psychology, audiology and physiotherapy).

At the lyceum and the gymnasium levels, special committees are currently actively seeking to identify issues facing special education providers, so that the latter group can develop solutions to turn these issues into learning opportunities in classroom practices. At the gymnasium level, special classes are gradually being provided based on each student's medical, psychological, speech, hearing and educational history. Attempts are also being made so that each student's instructional programme is evaluated in consultation with his/her parents. Based on the results of such evaluation, the student may attend a regular classroom with an itinerant teacher or resource teacher in a resource or special room in the school. All these students are entitled to the individualized instruction they need.

Private education

Private schools operate according to the Private School Laws of 1971. The establishment and operation of private tertiary-level institutions are regulated by the Laws 67(I)/1996 and 221(I)/2004, which also concern the establishment of the Council for Educational Evaluation and Accreditation (SEKAP). The Law 109(I) of 2005 regulates the establishment, operation and control of private universities.

Private nursery schools are run on a profit basis by individuals who must be qualified in child care. Both community and private nursery schools come under the jurisdiction of the Ministry of Education. They also come under the jurisdiction of the Ministry of Labour and Social Insurance. Private primary schools are mainly run by various religious groups on a non-profit basis. They are liable to supervision and inspection by the Ministry of Education. Private secondary schools are mainly directed towards commercial vocational orientation. As in the case of public schools, the courses offered extend over six years and the emphasis during the first three years is on general education. These schools are supported by fees paid by parents. Private foreign language schools are run on a non-profit basis by various religious groups and give more emphasis to languages and general academic education. Their courses extend over six or seven years. The languages of instruction are English, French, Italian or Arabic. A number of private tertiary institutions offer one- to four-year courses in various fields of study (e.g. secretarial studies, business administration, electrical, civil and mechanical engineering, hotel and catering, banking, accountancy and computer studies).



Means of instruction, equipment and infrastructure

During the last twenty years, a considerable number of new textbooks have been published by the Ministry to facilitate the implementation of the curriculum in the domains of Greek language and literature (including the works of Cypriot writers), classical Greek, mathematics, science, social studies, English as a foreign language, Greek-Turkish as foreign languages (including the first in a series of textbooks for ESP), philosophy, economics, computer science, music, art, primary and pre-primary education. In most cases, textbooks were prepared by practicing teachers under the guidance of departmental committees consisting of members of the inspectorate, representatives of the Pedagogical Institute and the Teachers' Union.

The main purpose of the Technical Education Curriculum Development Unit is to publish technical and vocational education textbooks. These books are written by teams of technical school teachers who are assisted for this purpose for three days a week. As there is a great shortage of suitable technical textbooks in Greek, the unit has been extremely busy for the past few years. Among the areas covered are: electricity, electrical installations, electronics, machine shop engineering, technical drawing, materials, welding, car mechanics, building and woodwork. In 1995, eight new textbooks were published. In addition, fifteen previous editions were republished and fifteen revised editions were also published, while another twenty textbooks are to be published shortly. Altogether, sixty textbooks have been published.

A primary concern of the government is to integrate new technologies in the field of education, aiming at the early prevention of the development of digital illiteracy. The Ministry of Education has already taken measures towards this direction by training teachers to incorporate new technologies in teaching-learning methods and by installing computers in schools. Having already initiated the innovation of installing computers and printers in primary schools, the Ministry of Education intends to have an average of one computer per four students. Additionally, the Ministry plans to introduce Information Technology in pre-primary schools as well. As a result, a set of one computer and one printer will be installed in every kindergarten classroom. The main objective of this reform is to familiarize children with information technology early on and to provide the necessary means to the teachers to use technology in the teaching/learning process. Given that the installed computers will have access to the Internet as well, two basic educational aims are expected to be furthermore achieved, i.e. the promotion of communication skills and the acknowledgement of other countries' ethics in the context of intercultural education.

Adult and non-formal education

Public non-formal education includes evening and afternoon classes offering instruction in subjects in which there is demand for more intensive tuition than is normally offered by formal education (e.g. foreign languages, computer science, and university entrance examinations). Non-formal education helps early school leavers and/or drop-outs to supplement their education or to increase their professional skills. It also helps secondary school graduates enter the world of work, and people already in the job market to advance their professional knowledge. In addition, it gives adults



opportunities to pursue interests which will enable them to develop their personalities and enhance their contribution to the social, cultural and economic life of the community.

Adult Education Centres have been operating since 1960 in rural areas and since 1974 in urban areas. Today, these centres exist all over Cyprus and offer opportunities for lifelong learning to thousands of individuals aged 15+. Participants have the opportunity to attend to courses of varied and diversified fields and be instructed by qualified teachers. In 2003/04, 18,677 adults attended 1,391 classes where 462 teachers offered their services.

Evening schools offer full-time general education that leads to the acquisition of a school leaving certificate, and can be considered as “second chance schools”. They operate from around mid-September to the end of May from around 5 to 9 p.m. in the premises of public schools. Those attending must be aged 18+, but an opportunity to attend such schools is also given to individuals who are 15 and have to work for a living or are housewives.

Private tertiary-level institutions offer a wide range of programmes of study which are tailored specifically for adults since classes are conducted in the evening. Programmes include business studies, engineering, social sciences, languages, education, hotel and tourism, administration, management, graphic design, computer science, among others.

The afternoon/evening classes of technical schools are flexibly organized to accommodate working individuals who may wish to attend either short modular courses that lead to the acquisition of a certificate or longer programmes that may lead to the acquisition of a certificate that is equivalent to the school leaving certificate of technical schools as far the technical component is concerned. Both the starting qualifications required and the methods used vary depending on the programme to be followed by the trainees.

Educational staff employed in non-formal education do not usually differ from those employed in formal education. In the case of educational institutions under the Ministry of Education, educational staff include individuals dividing their time between formal and non-formal education, or individuals seconded by the Ministry from formal to non-formal educational institutions. This is greatly facilitated by the fact that such classes usually function within the premises of formal day schools. The institutions which do not come under the Ministry of Education employ their own personnel.

In addition to the programmes run by the government, there are programmes run by companies themselves. The aim of these is to satisfy the short- or long-term needs of the company. If no public financial support is requested, each company can make its own arrangements regarding the educational programme it wishes to offer. There is no government intervention in such a case. If, however, a company requests a subsidy from the Human Resource Development Authority, then it must submit the proposed programme to the Authority for approval.



Teaching staff

Pre-service teacher training is offered by the Cyprus Pedagogical Institute. Most primary school teachers are graduates of a three-year study programme and hold a teacher's certificate; moreover, they usually complete a two-year probationary period before receiving permanent appointment. A secondary school teacher is required to have a university degree in the subject to be taught, and to attend a pre-service training course at the Pedagogical Institute, leading to a certificate of pre-service training. Prior to permanent appointment, a teacher may serve as a substitute for short- or long-term needs and maintain a temporary status.

In-service training of primary, general secondary and technical secondary school teachers is the task of the Pedagogical Institute. The Ministry of Education and Culture gives great importance to the high-quality training and development of teachers, a critical factor for the quality of education and the status of the profession. Primary school teachers receive an all-round pre-service education, as well as in-service training throughout their careers. The Pedagogical Institute, in cooperation with the Inspectorate, is responsible for the training provided to teachers and thus prepares a number of suitable seminars each year. Nevertheless, attending these seminars is not mandatory and therefore depends on the willingness of each teacher and not to the needs of the school. Head teachers receive in-service training for one year after they are promoted to be able to respond to the needs of their more demanding position.

The content of teacher training is revised over time to accommodate the new issues that arise in the educational field and to adequately equip teachers to respond to these new challenges. The quality of education offered is vastly affected by technological developments that influence the curriculum, the teaching and the learning methods used. Inevitably, developments in information technology have considerable implications for the training and retraining of teachers, who are now obliged to receive in-service education in using information technology in the classroom. Given the attempt made to introduce information technology in schools, such training is essential to familiarize teachers with the new environment.

Teachers also receive training on intercultural education, through seminars and conferences, to respond to the changing socio-cultural environment and be able to transmit the values of tolerance, respect, understanding and equality to their students. Other training seminars prepared by the Pedagogical Institute in response to the new challenges faced by primary education include seminars on emotional education, the European dimension of education, teaching English, information technology in education, teaching Greek as a second language as well as on a variety of other subjects.

The guidance and supervision of teachers is conducted by the inspectors, who are responsible for the guidance, supervision and evaluation of the teachers' work. The role of the inspectorate has evolved towards that of advisor and animator. The emphasis is on guidance and staff development through individual advice and seminars (at both regional and school levels) on methodology, subject matter, textbooks, teaching aids, etc. The inspectors frequently visit schools and classes. They also organize and conduct seminars at which a variety of educational problems

relating to the theory and practice of teaching are discussed. At these seminars, teachers may report their findings from an experimental approach or method which they have followed in the classroom or from a study they have made. In special subjects (such as music, home economics, physical education, art and foreign languages) as well as in pre-primary and adult education, guidance and support to teachers are given by groups of teachers specially trained in their respective domains. Guidance is also provided through handouts prepared by members of the inspectorate and departmental committees. There is no shortage of instructional personnel at any level or type of education in Cyprus. In fact, there is a large surplus of qualified secondary school teachers in all specializations.

Pre-service training of teachers for the different levels of education

Level of education	Type of training Institute	Admission requirements	Structure of studies	Qualifications-diplomas awarded
Lower general secondary education	Pedagogical Institute of Cyprus	All teachers with at least a Bachelor's degree appointed on probationary bases for 2 years	Length of studies: 2 days per week for 32 weeks during working time. The course comprises: general methodology, special subject methodology, psychology of the adolescent and educational research. Each participant has to complete a project or research paper at the end of the course	certificate of completion of in-service training
Upper general secondary education	same as above	same as above	same as above	same as above
Technical and vocational secondary education	same as above	same as above	same as above	same as above



Educational research and information

Most educational research in Cyprus is carried out by the Pedagogical Institute. The current priorities for educational research are those relating to students' achievement in the various disciplines, teacher education and evaluation, curricula and general education parameters.

The Research and Evaluation Department of the Pedagogical Institute provides assistance to the staff of the Institute who, besides their teaching duties, engage themselves in educational research. Their choice of topics for research depends on the needs presented by the Ministry of Education and Culture, as well as on their own interests. The research projects which have been undertaken by the staff of the Pedagogical Institute during the last two years are either comparative (i.e. the Reading Literacy Study in co-operation with the International Association for the Evaluation of Educational Achievement) or investigative projects (i.e. Microconcepts in mechanics; The effectiveness of the role of the department head in schools of secondary education; The impact of home economics on pupil nutrition during school breaks; Investigation of levels of physical fitness among Grade VI pupils in primary schools; The games kindergarten children mostly favour; and Factors affecting pupil achievement, among many others).

The object of the research projects is to provide information to the educational authorities in the area of educational planning and decision-making and to the Pedagogical Institute regarding the organization, improvement and assessment of in-service training seminars. It provides assistance to secondary and technical school teachers on probation, secondary deputy heads, and those who undertake research projects. It equally provides assistance on research methodology to educators who intend to improve their academic qualifications and engage themselves in educational research.

References

EURYDICE. *Focus on the structure of higher education in Europe 2006/07. National trends in the Bologna process*. EURYDICE, European Unit, Brussels, March 2007.

EURYDICE/CEDEFOP/ETF. *Structures of education, vocational training and adult education systems in Europe. Cyprus 2003/04*. Information provided by the EURYDICE Unit, Ministry of Education and Culture.

Ministry of Education and Culture. *Development of education 1994-1996. National report of Cyprus*. International Conference on Education, 45th session, Geneva, 1996.

Ministry of Education and Culture. *Development of education. National report of Cyprus*. International Conference on Education, 46th session, Geneva, 2001.

Ministry of Education and Culture. *National report of Cyprus*. International Conference on Education, 47th session, Geneva, 2004.



Web resources

Ministry of Education and Culture: <http://www.moec.gov.cy/> [In Greek. Last checked: April 2007.]

Cyprus Pedagogical Institute: <http://www.pi.ac.cy/> [In Greek. Last checked: April 2007.]

Education Service Commission: <http://www.eey.gov.cy/> [In Greek. Last checked: April 2007.]

EURYBASE, the information database on education systems in Europe: <http://www.eurydice.org/> [In several languages.]

For updated links, consult the Web page of the International Bureau of Education of UNESCO: <http://www.ibe.unesco.org/links.htm>