

# Integrated Watershed Management - Ecohydrology & Phytotechnology - - Manual -

# Integrated Watershed Management - Ecohydrology & Phytotechnology -

- Manual -



---

## UNITED NATIONS ENVIRONMENT PROGRAMME

*DIVISION OF TECHNOLOGY, INDUSTRY AND ECONOMICS - INTERNATIONAL ENVIRONMENTAL TECHNOLOGY CENTRE*

**Osaka Office**  
2-110 Ryokuchi koen, Tsurumi-ku,  
Osaka 538-0036 Japan  
Tel: +81-6-6915-4581  
Fax: +81-6-6915-0304

**Shiga Office**  
1091 Oroshimo-cho, Kusatsu City,  
Shiga 525-0001 Japan  
Tel: +81-77-568-4581  
Fax: +81-77-568-4587

---

Email: [ietc@unep.or.jp](mailto:ietc@unep.or.jp)  
URL: <http://www.unep.or.jp>

---

## UNEP's Copyright

Copyright 2004 UNEP

This publication may be reproduced in whole or in part and in any form for educational or non-profit purposes without special permission from the copyright holder, provided acknowledgement of the source is made. UNEP would appreciate receiving a copy of any publication that uses this publication as a source.

No use of this publication may be made for resale or for any other commercial purpose whatsoever without prior permission in writing from UNEP.

First edition 2004

The designations employed and the presentation of the material in this publication do not imply the expression of any opinion whatsoever on the part of the United Nations Environment Programme concerning the legal status of any country, territory, city or area or of its authorities, or concerning delimitation of its frontiers or boundaries. Moreover, the views expressed do not necessarily represent the decision or the stated policy of the United Nations Environment Programme, nor does citing of trade names or commercial processes constitute endorsement.

## UNITED NATIONS PUBLICATION

This publication is printed on paper made from 100 per cent recycled material.

The photographs on the front cover page are (top to bottom): 1. Willows - used for water quality improvement and bioenergy production (Photo: Nyga); 2. Engineering device for purifying water using aquatic macrophytes - City of Rostov on Don, Russia (photo: Santiago-Fandino); 3. Pillica River floodplain, part of a UNESCO/UNEP Demonstration Project (photo: Wagner-Lotkowska); 4. The Earth from space (photo: NASA).

The scheme on the back cover page is modified from Zalewski (2002). International Journal of Ecohydrology and Hydrobiology, vol. 2, no 1-4. Proceedings of the final Conference of the First Phase of the IHP-V Project 2.3/2.4 on Ecohydrology "The application of Ecohydrology to Water Resources Development and Management". Venice, Italy 16-18 September 2001.

Design: Kamil Zakrzewski  
Typesetting: Przemyslaw Nyga

Editors:  
**Maciej Zalewski**  
(ICE-PAS)  
**Iwona Wagner-Lotkowska**  
(CEHS-UL)

Assistant Editor:  
**Richard D. Roberts**  
(UNEP-GEMS/Water)

Coordination & Supervision:  
**Vicente Santiago-Fandino**  
(UNEP-IETC)  
**Philippe Pypaert**  
(UNESCO-ROSTE)



UNEP

The United Nations Environment Programme  
International Environmental Technology Centre  
2-110 Ryokuchi Koen, Tsurumi-ku, Osaka 538-0036  
1091 Oroshimo-cho, Kusatsu-City, Shiga 525-0001, Japan



UNESCO Regional Bureau for Science in Europe  
Palazzo Zorzi, Castello 4930  
30122 Venice, Italy



UNESCO International Hydrological Programme  
Division of Water Sciences  
1, rue Miollis 75732 Paris Cedex 15, France



Centre for Ecohydrological Studies  
University of Lodz  
12/16 Banacha Str., 90-237 Lodz, Poland



International Centre for Ecology  
Polish Academy of Sciences  
Warsaw, Dziekanow Lesny, 1 Konopnickiej Str.  
05-092 Lomianki, Poland

## ■ ACKNOWLEDGMENTS

The Manual is one of the results of the ongoing co-operation between the United Nations Environment Programme - Division of Technology, Industry and Economics - International Environmental Technology Centre (UNEP-DTIE-IETC) and the United Nations Educational, Scientific, and Cultural Organization - International Hydrological Programme (UNESCO-IHP), represented by the Regional Bureau for Science in Europe (UNESCO-ROSTE). A printed version has been separately produced by UNESCO IHP (ISBN: 92-9220-011-9, ISBN: 83-908410-8-8).

The Manual has been produced with the assistance and advice of the members of the Scientific Advisory Committee (SAC) of the Ecohydrology Initiative of UNESCO-IHP and in some cases with their direct participation.

The manual contains results of the first joint UNEP-IETC/UNESCO-IHP Ecohydrology & Phytotechnology Demonstration Project „Application of Ecohydrology and Phytotechnology for Water Resources Management and Sustainable Development”, on the Pilica River catchment in the Republic of Poland. This was developed and implemented by the International Centre for Ecology, Polish Academy of Sciences (ICE-PAS) and Centre for Ecohydrological Studies, University of Lodz (CEHS UL).

This publication contains results of research supported by grants: European Commission projects: EC-EVK1-2001-00182 - acronym TOXIC; EC-EVK2-2002-00546 - acronym MIDI-CHIP; EVK1 -CT-2001-00094 - acronym FAME; Polish Committee of Scientific Research grants: 6 PO4F 065 19, 3 PO4G 057 22, 6 PO4F 067 19, 6 PO4G 112 20.

The following experts contributed to the production of this manual:

- Chapter 1: M. Zalewski, I. Wagner-Lotkowska
- Chapter 2: M. Zalewski (A), V. Santiago-Fandino (B), I. Wagner-Lotkowska (A, B, C)
- Chapter 3: I. Wagner-Lotkowska (A, C, D, G), A. Magnuszewski (A, C), Z. Kaczmarek (B), A. Trojanowska (D), K. Krauze (E), M. Lapinska (F), K. Izydorczyk, A. Wojtal & P. Frankiewicz (H), L. Chicharo (I)
- Chapter 4: R. Kucharski, A. Sas-Nowosielska, M. Kuperberg (C), K. Krauze (B), J. Bocian (A)
- Chapter 5: A. Zdanowicz (A), K. Krauze (B), I. Wagner-Lotkowska, J. Markowska & J. Markowski (C)
- Chapter 6: M. Lapinska (A, B), A. Trojanowska (C), M. Zalewski (B)
- Chapter 7: A. Trojanowska (A), A. Bednarek (B), K. Izydorczyk (C), J. Mankiewicz, T. Jurczak, B. Romanowska-Duda, M. Tarczynska (D), A. Wojtal (E), P. Frankiewicz (F)
- Chapter 8: A. Chicharo (A, B), L. Chicharo (C)
- Chapter 9: R. Kucharski, A. Sas-Nowosielska & M. Kuperberg (A), L. Ryszkowski, A. Kedziora (B, C)
- Chapter 10: K. Krauze (B), I. Wagner-Lotkowska, E. Kiedrzynska, B. Sumorok (C), J. Bocian (A)
- Chapter 11: M. Lapinska (A, C), K. Krauze (B), Z. Kaczkowski (D)
- Chapter 12: I. Wagner-Lotkowska, K. Izydorczyk, T. Jurczak & M. Tarczynska (A), P. Frankiewicz (B), S. E. Jorgensen (C, D)
- Chapter 13: L. Chicharo
- Chapter 14: A. T. Calcagno (A), Z. Kaczmarek (B)

Special thanks to Boguslawa Brewinska-Zaras and Marta Rogalewicz for their help in preparing the final version of the manual.

## ■ PREFACE

The World Summit on Sustainable Development (WSSD) held in Johannesburg, South Africa in 2002 and the 3rd World Water Forum held in Kyoto, Japan in 2003 highlighted the importance of the UN Millennium Declaration and the Millennium Development Goals. Both events emphasized the importance of elaborating strong science to support sustainable development policy.

Further, the International Council for Scientific Unions (ICSU) declared that in the twenty-first century science „must become more problem-focused and apply an interdisciplinary approach to sustainable development issues in order for science to become more policy relevant“. Likewise, the UN World Commission for Sustainable Development (CSD), besides supporting the development and application of sound science towards sustainable development, also underscored the importance of developing and transferring environmentally sound technologies.

As the twenty-first century begins, it has been recognized that successfully managing water resources is an essential component of achieving sustainable development. However, due to the anthropogenic modification of the hydrological cycle by deforestation, urbanization and irrigation, water resources have been overexploited, degraded and wasted, resulting in higher risks to human health, economic and social development as well as to the functioning of ecosystems and the preservation of the environment.

In light of this scenario, there is a need to develop a novel, environmental management approach within the context of Integrated Watershed Management (IWM). This is where ecohydrology as well as the application of Environmentally Sound Technologies (ESTs) such as phytotechnology constitute a new dimension.

The concept of ecohydrology and its scientific foundations were developed by UNESCO-IHP over the past few decades. The integration of the two components - hydrology and ecology - by means of regulating hydrological, biotic and landscape interactions and processes, has contributed to improving ecosystems' resistance to stress. The concept of phytotechnology, developed by the UNEP-International Environmental Technology Center, encompasses a variety of environmental approaches and technologies based on the ecosystem services that plants provide. The use of phytotechnologies, together with the development of ecohydrology, can help prevent, control and even reverse the degradation of water resources.

Considering the complementarities of ecohydrology and phytotechnology and, taking into account the calls for an interdisciplinary approach by the WSSD, the 3rd WWF and the ICSU, UNESCO-IHP, UNESCO-Regional Bureau for Science in Europe (ROSTE) and UNEP-IETC merged their efforts through a number of projects and activities, including the present publication. The „Manual for Integrated Watershed Management“ follows on the „Guidelines for the Integrated Management of the Watershed“, published in 2002 by the same agencies, in which the general philosophy of ecohydrology and phytotechnology was put together for the first time, providing the reader an understanding of the concepts and their application to the integrated management of watersheds.

Due to the great interest generated by the Guidelines, and in order to provide practitioners with practical information about how to implement the concepts and approaches considered within ecohydrology and phytotechnology, the Scientific Advisory Committee of Ecohydrology IHP-VI and UNEP-IETC decided to produce the present publication. The manual has been designed to improve decision makers' identifica-

tion capabilities and understanding of mechanisms used to solve problems related to water resource degradation within watersheds. It is also expected that a larger audience would benefit from the present publication (i.e., technical experts, scientists, NGOs and others interested in water resource management.)

Bearing in mind once again that one of the major questions in achieving sustainable development is „whether scientific evidence can successfully overcome social, economic and political resistance“ (Kennedy, Science 2003), we sincerely hope that the new approaches of ecohydrology and phytotechnology, developed in IHP-V and VI and supported by UNEP-IETC, will generate positive socioeconomic benefits for those living in watersheds in addition to improving the water resources quality.

Steve Halls

Handwritten signature of Steve Halls in black ink, appearing as 'S. A. Halls'.

Director  
UNEP-IETC

Andras Szöllösi-Nagy

Handwritten signature of Andras Szöllösi-Nagy in black ink, appearing as 'ASN'.

Director  
Division of Water Sciences, UNESCO  
Secretary of the UNESCO IHP

## ■ TABLE OF CONTENTS

<b>Acknowledgments</b>	6
<b>Preface</b>	7
<b>Table of contents</b>	9
<b>PART ONE: INTRODUCTION</b>	
<b>1. About this Manual</b>	
1.A. What is the goal of this manual?	13
1.B. Why is this manual needed?	14
1.C. What is covered by this manual?	15
1.D. Who should use this manual?	16
<b>2. What are Ecohydrology &amp; Phytotechnology?</b>	
2.A. What is ecohydrology?	17
2.B. What is phytotechnology?	21
2.C. Application of ecohydrology and phytotechnology for water resources management and sustainable development. UNESCO/UNEP Demonstration Project	25
<b>3. Basic Concepts &amp; Definitions</b>	
3.A. Watershed	30
3.B. Climate	31
3.C. Hydrological cycle	32
3.D. Biogeochemical cycles	33
3.E. Landscape structure and vegetation cover	34
3.F. Streams and rivers	35
3.G. Lakes and reservoirs	36
3.H. Freshwater Biota	37
3.I. Estuarine and coastal areas	40
<b>PART TWO: SURVEYS &amp; ASSESSMENT: How to Assess &amp; Quantify Specific Issues in Watersheds</b>	
<b>4. LANDSCAPES: Defining Critical Areas in Watersheds</b>	
4.A. How urbanization and industries influence water quality	45
4.B. How to assess landscape impacts on water quality	49
4.C. How to assess soil contamination	56
<b>5. LAND-WATER INTERACTIONS: How to Assess their Effectiveness</b>	
5.A. Can ground water influence surface water quality	61
5.B. How to assess the efficiency of ecotones in nutrient removal	66
5.C. How to estimate effects of riparian areas and floodplains on water quality and quantity	71
<b>6. STREAMS &amp; RIVERS: Defining their Quality &amp; Absorbing Capacity</b>	
6.A. Bioassays - A tool to measure ecosystem quality	75
6.B. Fish communities - indicators of riverine degradation	79
6.C. Bacteria, fungi and microbial processes	90
<b>7. LAKES &amp; RESERVOIRS: Defining their Ecosystem Status</b>	
7.A. What happens to phosphorus in a water body: Sedimentation	97
7.B. What happens to nitrogen in a water body: Denitrification	101
7.C. How to assess phytoplankton biomass?	106
7.D. Why are cyanobacterial blooms harmful	110
7.E. Assessment of zooplankton communities	116
7.F. Assessment of fish communities	121



<b>8. ESTUARINE &amp; COASTAL AREAS: How &amp; What to Measure</b>	
8.A. Water Chemistry	124
8.B. Water Circulation	128
8.C. Structure of Biota	131
<b>PART THREE: MANAGEMENT: How to Prevent Degradation &amp; Restore Watersheds</b>	
<b>9. LANDSCAPE MANAGEMENT: Regulating Pollution Exports &amp; Hydrological Cycles</b>	
9.A. Phytoremediation of soils	139
9.B. How to manage water cycles in watersheds	144
9.C. Control of diffuse pollutant inputs to water bodies	150
<b>10. LAND-WATER INTERACTIONS: Reduction of Contamination Transport</b>	
10.A. Constructed wetlands: How to combine sewage treatment with phytotechnology	154
10.B. Ecotones: How to diminish nutrient transport from landscapes	158
10.C. Floodplains and natural wetlands: Reduction of nutrient transport	163
<b>11. MANAGEMENT OF STREAMS &amp; RIVERS: How to Enhance Absorbing Capacity against Human Impacts</b>	
11.A. Restoration of physical structure in a river	169
11.B. Restoration of vegetation: Increasing nutrient retention capacity and self-purification ability	175
11.C. Management of shoreline and riverbed structure: Increasing fish yields	180
11.D. Ecohydrological approach in pond aquaculture	184
<b>12. RESERVOIR &amp; LAKE MANAGEMENT: Improvement of Water Quality</b>	
12.A. Ecohydrological methods of algal bloom control	188
12.B. How to manage biotic structure in a reservoir	194
12.C. Harvesting macrophytes and macroalgae	197
12.D. Other methods of water quality improvement	199
<b>13. ESTUARINE &amp; COASTAL AREAS: How to prevent degradation and restore</b>	202
<b>14. OTHER ASPECTS OF WATERSHED MANAGEMENT</b>	
14.A. Socio-economic aspects of ecohydrology & phytotechnology applications in integrated watershed management (IWM)	209
14.B. Can global climate change affect management outcomes?	212
<b>APPENDIX</b>	
Appendix	219
Glossary of Terms	226
References	231
Contributing Authors	246



## PART ONE: INTRODUCTION



## ■ 1.A. What is the goal of this Manual

### ECOHYDROLOGY & PHYTOTECNOLOGY PROGRAMMES

The concept of ecohydrology and its scientific foundations were developed by International Hydrological Programme (IHP) of UNESCO. According to ecohydrology, through the manipulation of biota and hydrology interactions in a landscape, the possibility of augmenting ecosystems resilience to anthropogenic changes can be achieved.

Phytotechnology, on the other hand, as the use of vegetation and its natural services for environmental quality improvement, is being developed by the UNEP International Environmental Technology Centre (UNEP - IETC). This can complement ecohydrology through, for example, development of techniques of vegetation use to reducing erosion of shorelines, preserving and restoring soils and landscapes, controlling and preventing pollution, as well as restoring habitats.

### ECOHYDROLOGY & PHYTOTECNOLOGY GUIDELINES FOR IWM

The complementarities of ecohydrology and phytotechnology, together with the similar interests in water resources management of UNEP-IETC, UNESCO-IHP and UNESCO-Regional Bureau for Science in Europe (ROSTE), led to a joint project that produced the „Guidelines for the Integrated Management of the Watershed“. The Guidelines provided a strong scientific basis for the concepts of ecohydrology and phytotechnology as well as a theoretical background for their application in Integrated Watershed Management (IWM). They presented ecohydrological approach to understanding of processes regulating dynamics of water basins, as well as the mechanisms for increasing absorbing capacity of ecosystems against human impacts.

### THIS MANUAL

Being a continuation of the scientific background provided in the „Guidelines“, this publication does not present to a reader any detailed theoretical considerations about the mechanisms of the ecohydrological and phytotechnological processes. Discussion of the theoretical aspects of the concepts in this publication is limited to an essential minimum. The Manual complements the Guidelines and focuses on the methodology and practical aspects of implementing ecohydrological and phytotechnological concepts in watershed management.

Therefore, the objectives of this manual are to:

- ▶ provide examples of ecohydrology and phytotechnology in water resources management;
- ▶ assist decision makers, technical experts and scientists to manage watersheds and related water bodies; and
- ▶ facilitate and promote the better understanding of the opportunities that the application of ecohydrology and phytotechnology offer for this purpose.

### HOW TO USE THE GUIDELINES AND MANUAL

In order to benefit from both practical information presented in the Manual as well as the scientific background provided by the Guidelines, it is recommended to get familiar with both of the complementary publications.

Therefore, in the section named:

#### **MAKE SURE TO CHECK THESE RESOURCES:**

located at the end of each chapter, you will find references to corresponding chapters of the UNEP / UNESCO Guidelines for the Integrated Management of the Watershed - Phytotechnology and Ecohydrology.



UNESCO/UNEP  
*Guidelines for the Integrated Management  
 of the Watershed  
 Phytotechnology and Ecohydrology*  
 Freshwater Management Series No. 5  
 UNEP, 2002

## ■ 1.B. WHY IS THIS MANUAL NEEDED?

### FRESHWATER DEGRADATION IS MUCH MORE THAN JUST POLLUTION

At the beginning of the 21st century, the increasing human population has become a major factor in progressive environmental degradation on the global scale. Although the traditional perception of freshwater degradation has been usually linked to pollution, increasing human activities in a catchment have more profound effects on environmental quality. Most river basins in the world have been dramatically modified due to unsustainable development of agriculture, grazing, deforestation, and urbanization. These disturbances have been changing local and regional climates, hydrological cycles as well as evolutionary established biogeochemical cycles in a catchment. Therefore, it became evident that the degradation of river ecosystems has been of a two-dimensional nature (Box 1.1):

- ▶ first - pollution, which can be eliminated to a large extent by technologies;
- ▶ second - and much more complex, degradation of evolutionary established water and nutrient cycling.

### WHY DOES THE DEGRADATION OF ECOLOGICAL PROCESSES CAUSE RISK TO HUMANS?

Degradation of biological structures and ecological processes means a reduction in an ecosystem's

carrying capacity. As a consequence, with the present rate of society development and environmental degradation, it is expected that during the next 30 to 60 years, human imperatives may clash with the carrying capacity of the global environment (see Guideline, chapter I). Such a clash would be nothing less than catastrophic for humanity. Today changes of ecological processes at a catchment scale have become strongly manifested by the continuous decrease of water quality and the enhanced risks of floods and droughts in many regions of the world. It is evident that water is becoming scarcer for society in some developed and many developing countries. This results in a higher risk to not only human health, but also to economic and societal development. In this situation, development of an integrated approach to environmental management, based on the harmonization of technical and ecological measures, is necessary to achieve sustainable development. Integrating different branches of environmental science (such as, e.g., ecology and hydrology) can help provide an understanding of environmental changes as well the knowledge-base necessary to apply efficient measures to improve the quality and, at the same time, increase absorbing capacity of the environment for human impacts.

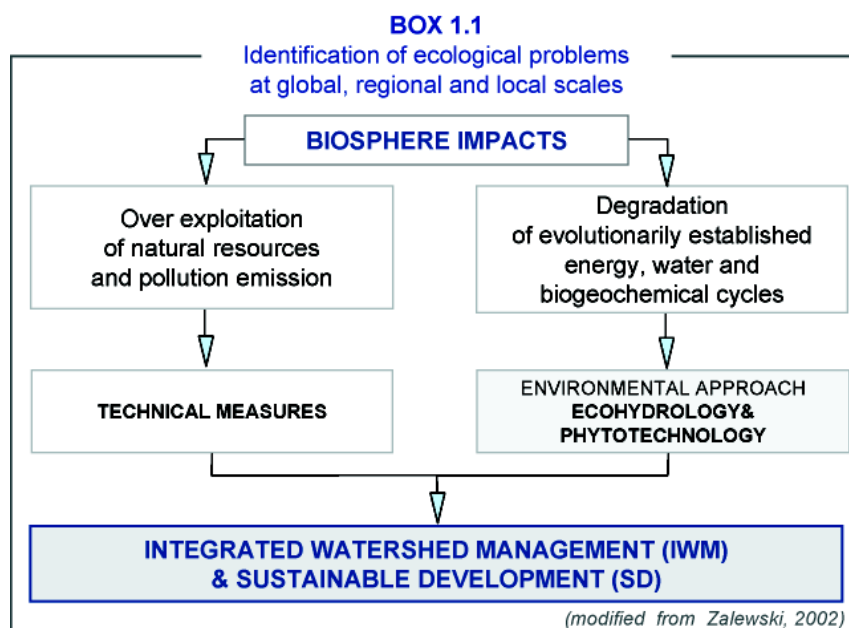

## 1.C. WHAT IS COVERED BY THIS MANUAL?

This manual provides a new approach based on application of across disciplines knowledge in holistic management of water resources. It encourages a reader to have a broader, interdisciplinary view on various aspects of IWM, with special emphasis on practical use of understanding relationships between hydrology and biota and their use in order to control environment quality.

According to the presented approach, for sustainable management of water resources quality and stabilization of hydrological cycle, it is necessary to harmonize technological and ecological measures. Ecological measures should be based on understanding of biota-water interplay in various scales of a catchment. Therefore, the manual has been organized hierarchically, in order to easily identify the necessary measures in the particular areas of a catchment, such as (Box 1.2):

- ▶ **LANDSCAPE**
- ▶ **LAND-WATER INTERFACE**
- ▶ **STREAMS & RIVERS**
- ▶ **LAKES & RESERVOIRS**
- ▶ **ESTUARINE & COASTAL AREAS**

The manual has been divided into the following major sections:

- ▶ **PART ONE: INTRODUCTION:** presents basic theory for ecohydrology and phytotechnology concepts and introduces basic definitions essential for understanding in order to apply ecohydrological and phytotechnological measures.
- ▶ **PART TWO: SURVEYS & ASSESSMENT:** presents an overview of methods for assessment of potential issues in watersheds, focusing a reader's attention on possible variations and interpretations of results from the point of view of ecohydrology and phytotechnology.
- ▶ **PART THREE: MANAGEMENT:** presents practical suggestions and recommendations for application of ecohydrology and phytotechnology in IWM.

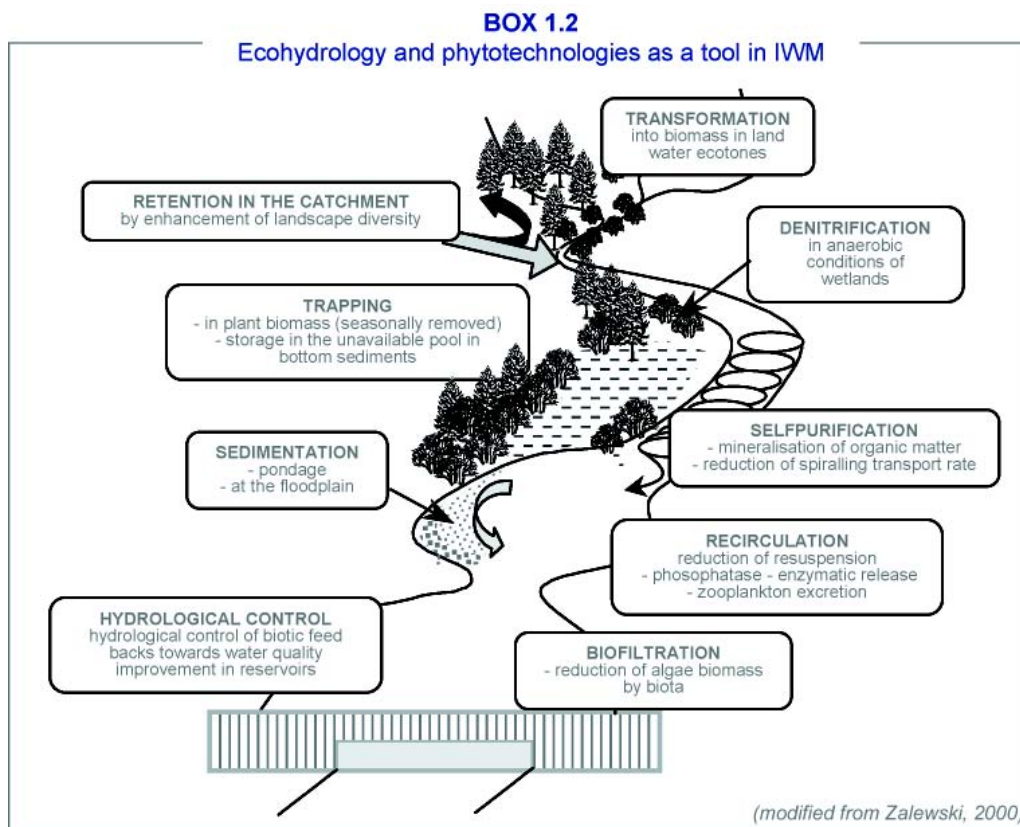

## ■ 1.D. WHO SHOULD USE THIS MANUAL?

Anyone who is involved in Integrated Watershed Management (IWM) should find this manual of interest. In particular, those who deal with **improvement** of degraded aquatic and terrestrial environments, as well as those interested in **sustainable management and maintaining** good quality water resources, will find this manual useful.

In the traditional approach to water resources management, hydrotechnical engineers have usually been the major target group. Although they still play a fundamental role as those who **eliminate threats**, such as for example, point sources of pollution, it has become obvious that to achieve high-quality results with environmental issues, the technical approach alone is not enough. This manual encourages and provides an understanding of the need for a **broader view** on catchment management. This involves the

application of new strategies that amplify the opportunities provided by an understanding of ecosystem properties in order to enhance their **carrying capacity** against increasing human impacts.

Successful implementation of any strategy in IWM depends on participation of various groups of people working and living in a catchment (Box 1.3). Therefore, we believe, that not only professionals with various expertise, but also a wide range of practitioners, politicians and the public will find the manual of interest. In particular, the manual has been dedicated to:

- ▶ environmental managers and technical experts;
- ▶ local and regional authorities, decision makers in government agencies and non-governmental organizations;
- ▶ coordinators and consultants; and
- ▶ landowners.

### BOX 1.3

#### Changing the stakeholder involvement in IWRM

*Stakeholder music festival with 2000 sicuris in front of the River Huasamayo*

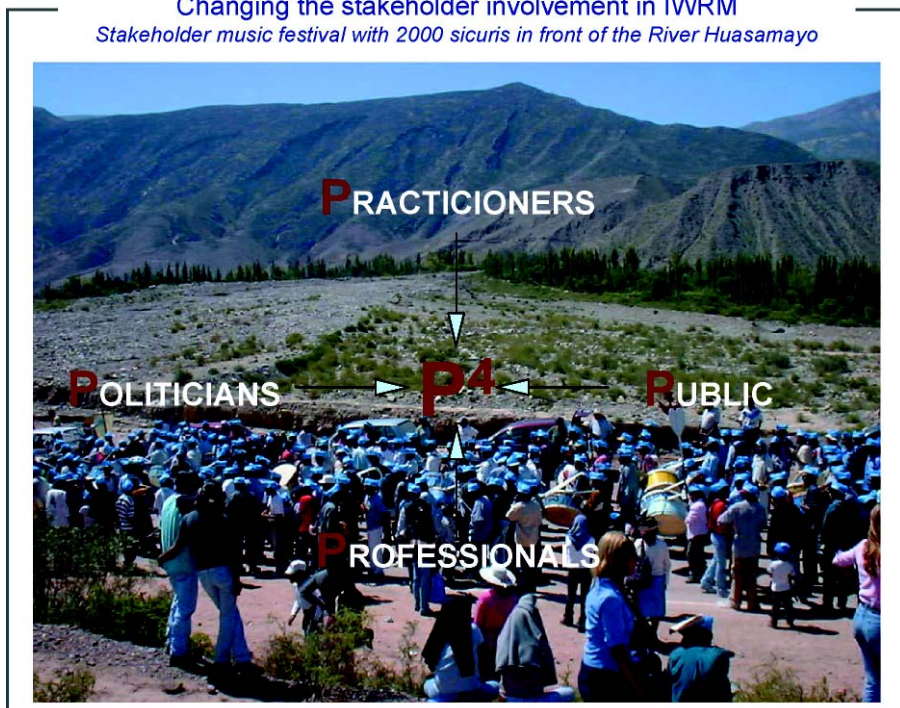

## ■ 2.A. WHAT IS ECOHYDROLOGY?

### INTEGRATION OF SCIENCES...

According to the strategy defined by ICSU, science in the 21st century should actively participate in creating a vision, strategy and implementation methodology essential to the support of sustainable development. The approach that accelerates the above actions should be based on the integration of various interdisciplinary and transdisciplinary fields of science. The developmental conditions required for comprehensive, integrative and interdisciplinary scientific research is „maturity“ of the empirical disciplines that participate in the integration process.

The progress that took place in ecological sciences in the last years of the 20th century, allowed for major advancements of knowledge. A level was attained that permitted an attempt to integrate ecological sciences with the more advanced scientific fields to great extend expresses by physics and mathematics hydrology. This integration created a platform for the development of a new discipline (Zalewski et al., 1997; Zalewski, 2000). Ecohydrology (EH), has been formulated and developed within the framework of UNESCO's International Hydrological Programme, IHP -V.

### DEFINING ECOHYDROLOGY...

The basis for the development and advancement of interdisciplinary science and related research should be the defining of a new scope and formulation of new key questions to be answered (Keyfitz, 1993). In the course of the genesis of ecohydrology, it was assumed that the questions should meet the two following fundamental conditions:

1. They should be related to the dynamics of two entities in such a way that the answer without consideration of one of the two components (both ways E <-> H) would be impossible. In other words, this question should enable the defining of relationships between hydrological and biological processes in order to obtain comprehensive empirical data at the same spatial and temporal scales.

2. The results of the empirical analysis should test the whole range of processes (from a molecular to catchment scale), should enable their spatial/temporal integration and should be convertible to large-scale management measures in order to enable further testing of the hypotheses.

Taking into account the above conditions, the key questions for ecohydrology have been defined based on an in-depth understanding of the interplay between biological and hydrological processes and the factors that regulate and shape them. The hypotheses have been defined in the form of the following questions:

**Hypothesis H1:** „The regulation of hydrological parameters in an ecosystem or catchment can be applied for controlling biological processes“.

**Hypothesis H2:** „The shaping of the biological structure of an ecosystem(s) in a catchment can be applied to regulating hydrological processes“.

**Hypothesis H3:** „Both types of regulation (H2 and H3) integrated at a catchment scale and in a synergistic way can be applied to the sustainable development of freshwater resources, measured as the improvement of water quality and quantity (providing of ecosystem services)“ (Zalewski, 2000). It should be stressed that according to the ecohydrology concept, the overall goal defined in the above hypotheses is the sustainable management of water resources. This should be focused on the enhancement of ecosystem carrying capacity against anthropogenic stresses.

### WHAT IS ECOHYDROLOGY?

Ecohydrology is a scientific concept applied to environmental problem-solving (Zalewski et al., 1997). It quantifies and explains the relationships between hydrological processes and biotic dynamics at a catchment scale.

The concept is based upon the assumption that **sustainable development of water resources is dependent on the ability to restore and maintain evolutionarily established processes of water and nutrient circulation and energy flows at the basin scale.**

This depends on an in-depth understanding of a whole range of processes involved that have a two-dimensional character:

- ▶ **temporal:** spanning a time frame from the past to the present with due consideration of future global change scenarios; and
- ▶ **spatial:** understanding the dynamic role of aquatic and terrestrial biota over a range of scales from the molecular- to the basin-scale.

Both dimensions should serve as a reference system for enhancing the buffering capacity of ecosystems against human impacts by using ecosystem properties as a management tool. This, in turn, depends on the development, dissemination, and implementation of interdisciplinary principles and knowledge based on recent advances in environmental science.

#### ECOHYDROLOGY KEY ASSUMPTIONS AND PRINCIPLES

Up to the time when the ecohydrology concept was defined, hydrologists considered aquatic biota mostly as an indicative system for monitoring while hydrobiologists considered hydrological processes as a disturbance factor.

The ecohydrology paradigm, which is based on functional relationships between hydrology and biota (Zalewski et al. 1997, Zalewski 2000; 2002), can be expressed in three key assumptions.

##### Key assumptions of EH

- ▶ **REGULATION** of hydrology by shaping biota and, vice versa, regulation of biota by altering hydrology.
- ▶ **INTEGRATION** - at the basin scale various types of regulations (E ↔ H) act in a synergistic way to improve and stabilize the quality of water resources.
- ▶ **HARMONIZATION** of ecohydrological measures with necessary hydrotechnical solutions (e.g., dams, sewage treatment plants, levees at urbanized areas, etc.)

Following these assumptions the concept of ecohydrology is based on three principles.

#### Principles

1. **FRAMEWORK** - Integration of the catchment, water and its biota into one entity, including:
  - ▶ **Scale** - the mesoscale cycle of water circulation within a basin is a template for the quantification of ecological processes;
  - ▶ **Dynamics** - water and temperature are the driving forces for both terrestrial and freshwater ecosystems;
  - ▶ **Hierarchy of factors** - abiotic (e.g., hydrological) processes are dominant in regulating ecosystem functioning. Biotic interactions may manifest themselves when abiotic factors are stable and predictable.
2. **TARGET** - Understanding evolutionarily established ecohydrological processes is crucial for a **proactive approach** to the sustainable management of freshwater resources. It assumes that it is not enough to simply protect ecosystems but, in the face of increasing global changes (such as increasing population, energy consumption, global climate change), it is necessary to **increase the carrying capacity of ecosystems, and their resistance and resilience, to absorb human-induced impacts.**
3. **METHODOLOGY** - ecohydrology uses ecosystem properties as a management tool. It is applied by using biota to control hydrological processes and, vice versa, by using hydrology to regulate biota. Scientific basis for the methodological aspect of using biota for water quality improvement has been seriously advanced by ecological engineering (e.g., Mitsch & Jorgensen, 2004).

#### Technical approach is not enough...

The importance of the effort to develop the ecohydrology approach increased with the publication of the paper by Meybeck (2003) in which he justifies the name of Anthropocene for the present era. Based on an in-depth analysis of published studies, he demonstrated that the modification of aquatic systems by human pressures (e.g., flood regulation, fragmentation, sedimentation imbalance, salinization, contamination, eutrophication, etc.) has increased to a level that no longer



can be considered as being controlled by only natural processes (climate, relief, vegetation, limnology), thus defining a new era that we have already entered.

The decline in water quality and biodiversity, observed at the global scale in both developed and developing countries, has provided evidence that the traditional „mechanistic“ approach focused on **elimination of threats**, such as point source pollution and flood control, is crucial but not sufficient. This is because purely technical control, without understanding and considering biotic dynamics, constitutes a more trial and error approach to water management than the implementation of a policy toward sustainable water use. While elements of this approach remain valid and viable, a technical solution alone is clearly insufficient for the sustainable use of the world's water resources. To guarantee the sustainability of freshwater resource use, it is necessary not only to reduce or eliminate the discharge of pollutants, but also to extend the number of potential tools to manage the degradation of ecological processes in landscapes. Such a more efficient approach must be based on an understanding of the temporal and spatial patterns of catchment scale water dynamics.

### ECOHYDROLOGY - CREATING OPPORTUNITIES

Human survival and the preservation of biodiversity on Earth are dependent on our ability to maintain the integrity of ecological processes. Therefore, one of the fundamental tenets for the sustainable development of water resources is the maintenance of a homeostatic equilibrium within an ecosystem.

At the present level of human impacts on ecosystems, it is necessary to **increase the opportunities** for ecosystems (Box 2.1). It can be achieved by increasing the absorbing capacity of ecosystems against human impacts that continue to increase. Ecohydrology as an approach provides tools to achieve this goal by defining new approaches to freshwater protection, restoration and management.

### ECOHYDROLOGY AS AN INTEGRATIVE APPROACH

The formulation of the ecohydrology concept defined in UNESCO IHP V was to a large extent a logical consequence of the progress of river ecology (Zalewski, 2000; Zalewski & Robarts, 2003). The awareness of a need for integration of hydrology and ecology appears in the hydrobiology and hydrology scientific papers of the 1970's (Zalewski et al., 1997). However, only in the 1990's did

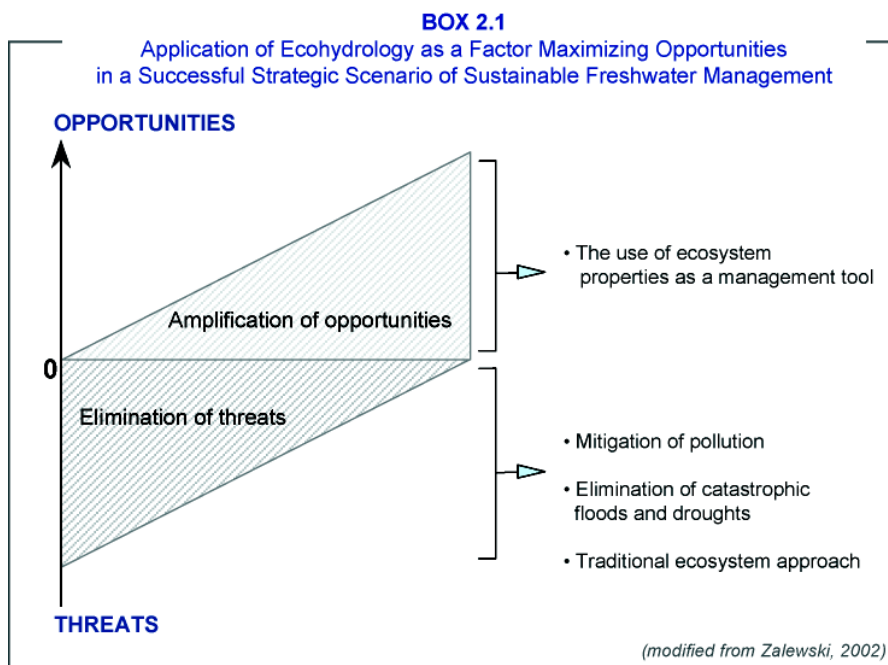

independent research directed to the interactions between the hydrosphere and biosphere become a subject of research for scientists in various fields. This created a basis for the holistic approach to understanding interactions between ecological and hydrological processes at a catchment scale and directed at the development of practical approaches for sustainable watershed management (Box 2.2). Among others, the broad scope of the research covered the following aspects:

- ▶ The relationship between vegetation, soil and water based on an understanding of the physiological properties of plants was presented by Baird & Wilby (1999).
- ▶ Considerable progress was made in understanding the role of vegetation in water cycling processes in a landscape through research by Rodriguez-Iturbe (2001) and that done within the IGBP BAHC programme (Vorosmarty, 2000).
- ▶ The multidimensional role of the buffering by ecotone zones between land and water have been well defined within the framework of the UNESCO MAB Programme (Naiman et al., 1989; Zalewski, Schiemer Thorpe, 1996, 2001; Gilbert et al., 1997).
- ▶ Application of ecological engineering, e.g., to the management of wetlands for water purification from excessive nutrient loads based on ecological theory and mathematical modelling, has been developed by Jorgensen & Mitsch (1996).
- ▶ Effect of hydrological regimes on vegetation succession of grasslands and swamps has been analysed by Witte & Runhar (2001).
- ▶ Reduction of nutrient loads to lowland reservoirs by enhancement of their retention in floodplains has been demonstrated by Wagner & Zalewski (2000).
- ▶ Control of eutrophication symptoms (elimination of toxic algal blooms through regulation of water levels for control of trophic cascades) has been evidenced by Zalewski et al. (1990, 2000).
- ▶ Some research has been undertaken on the control of water quality and dissolved oxygen content under ice cover during winter in dam reservoirs by regulation of the outlet (Timchenko et al., 2000).
- ▶ Regulation of the timing of water release on the Parana River (Porto Prima Vera Dam) in order to maintain fish migration, preserve biodiversity and fish production, has been investigated by Agostinho et al. (2001).
- ▶ Examination of the possibilities of managing coastal waters and diminishing their eutrophication using ecohydrology at a basin scale has been initiated by Wolanski et al. (2004).

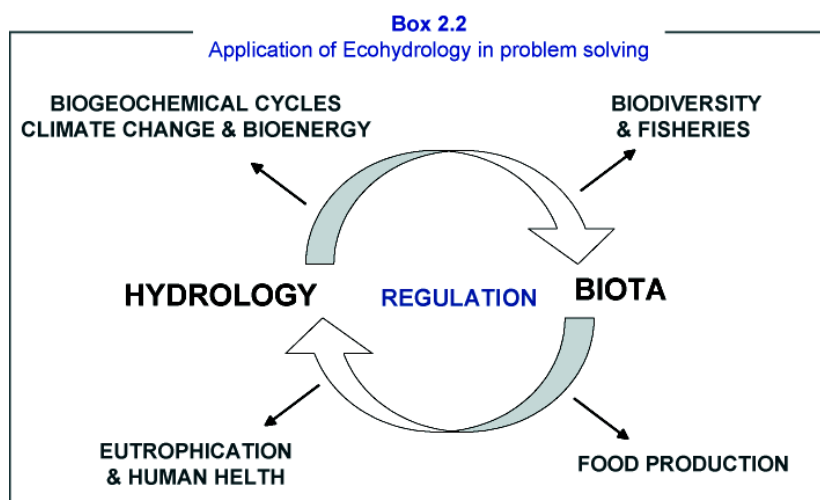

**MAKE SURE TO CHECK THESE RESOURCES:**

Guidelines: chapters 1, 2

## 2.B. WHAT IS PHYTOTECHNOLOGY?

### WHAT IS PHYTOTECHNOLOGY?

In general, the term **phytotechnology** describes the application of science and engineering to examine problems and provide solutions involving **plants**. The term itself is helpful in promoting a broader understanding of the importance of plants and their beneficial role within both societal and natural systems. A central component of this concept is the use of plants as **living environmentally sound technologies** (ESTs) that provide services in addressing environmental issues. In the context of this manual phytotechnologies are related to environmental problems and the provision of solutions within Integrated Watershed Management.

Phytotechnological applications employ **ecological engineering** (Mitsch & Jorgensen, 2004) principles and are considered to be ecotechnologies. Ecotechnologies are dependent on the self-regulating capabilities of ecosystems and nature. The focus on, and use of, biological species, communities, and ecosystems distinguishes ecotechnologies from more conventional engineering-technological approaches, which seldom consider integrative ecosystem-based approaches (UNEP, 2003).

### WHAT ARE THE ENVIRONMENTAL APPLICATIONS FOR PHYTOTECHNOLOGIES?

#### General categories for phytotechnological applications

Environmentally beneficial applications of phytotechnology can generally be divided into five categories (Box 2.3). The **integrated ecosystem management** component focuses on the use of phytotechnology to augment the capacity of natural systems to absorb impacts by serving as natural buffers. The **prevention** component is related to avoiding degradation effects originating from the release of pollutants into the environment or destruction of habitats (this also brings together the need to modify non-sustainable habits and behaviours of society). The **control** component mainly addresses the management of pollutants releases while rendering them harmless through natural processes. The **remediation and restoration** component considers methods and applications to bring back degraded ecosystems or the construction of artificial ones. **Monitoring and assessment** involves the use of bioindicators to follow up and assess conditions and changes in the environment due to natural and/or anthropogenic disturbances.

**BOX 2.3**

#### Environmentally beneficial applications of phytotechnology

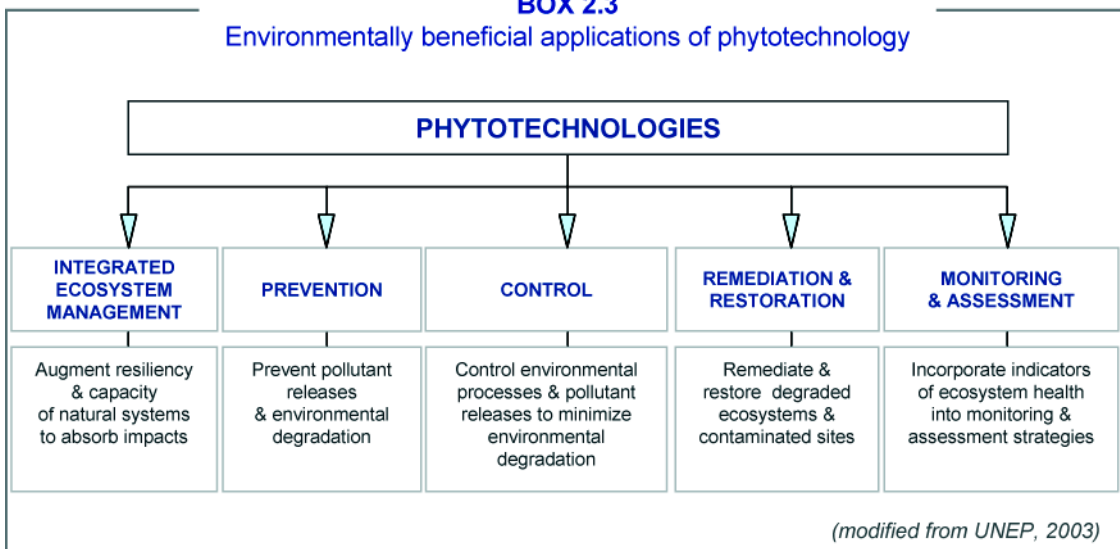

### Benefits of the applications of phytotechnologies

Their application may increase the functioning of ecological systems and hence the value of natural capital and natural services provided by ecosystems as a whole. The term „ecosystem services“ or „natural services“ refers to the conditions and processes through which natural ecosystems sustain and fulfill human life (Daily, 1977). These services are the result of complex natural cycles driven by solar energy, influencing the functioning of the biosphere in a number of different ways. Ecosystem services maintaining biodiversity and the production of ecosystem goods, such as food, timber, energy and natural fiber, as well as many pharmaceuticals, industrial products, and their precursors. The harvest and trade of these goods is based on „natural capital“ and hence are an important part of the global economy. In addition, ecological services include life support functions, such as protecting watersheds, reducing erosion, providing habitats for wild species, as well as the cleaning, recycling, and renewal of systems. Plants are a fundamental part of the world’s natural capital base due to the services they provide. The value of natural capital is increased by augmenting the capacity of ecological systems to function effectively. Some examples of the benefits of ecological services are:

- purification of air and water;
- mitigation of floods and droughts;
- detoxification and decomposition of wastes;
- generation and renewal of soil and soil fertility;
- translocation of nutrients;
- pest control;
- biomass production from simple elements through photosynthesis, and
- moderation of temperature, wind force and wave action.

### Examples of phytotechnological applications

Phytotechnology can be applied for solving several ecological problems by the direct use of plants for in situ (or „in place“) removal or degradation of contaminants or improving the physical structure of an ecosystem and hence it’s functioning. Phytotechnology covers a variety of low cost, so-

lar energy driven cleanup techniques. At some sites with low levels of environmental degradation they can be used in place of conventional technical solutions. In other cases, they can be applied together with them a final step towards refined environmental improvement. Some specific examples of phytotechnological applications include (UNEP, 2003):

- Reduction and management of problems related to **point and non-point sources of pollution** through the use of natural or constructed wetlands (usually coupled with conventional methods).
- Facilitating the **recovery of degraded ecosystems and soils**, such as brown fields or post industrial sites, or, for example, in the case of mine-tailing fields and dumping sites. Also they are widely used for aquatic and terrestrial ecotone recovery.
- **Sinks for carbon dioxide** to mitigate the impacts of climate change through reforestation and afforestation.
- Augmentation of the **environmental capacity of urban areas** to mitigate pollution impacts and moderate energy extremes. An example is the use of rooftop vegetation, or „green roofs“ to thermally insulate buildings as well as to avoid or reduce the formation of „heat islands“. They can also be used to increase land beautification and urban biodiversity.

### WHY IS PHYTO TECHNOLOGY USED IN IWM?

Specific applications of phytotechnologies in integrated watershed management are complementary to ecohydrology. The biota, hence plants, are key players in restoring water and biogeochemical cycles augmenting the carrying capacity, resilience and functionality of ecosystems (UNEP, 2003). In Box 2.4 the role of phytotechnology in IWM is presented in schematic form while in the following information some of the reasons behind their application are given:

- ▶ Plants form the first level of ecosystem structure (primary producers) and, therefore, control energy flow and nutrient cycling in landscapes. Control of vegetation structure

can be used for **transformation and retention of nutrients and pollutants**.

- ▶ Plant cover is one of the most dynamic and vulnerable components for the regulation of the water cycle in a watershed. It is fundamental to the evapotranspiration rate and, therefore, can help to **mitigate effects of floods and droughts**.
- ▶ Production of plant biomass provides **alternative sources of energy (bioenergy)**, resulting in reduction of CO<sub>2</sub> emissions from burning fossil fuels.
- ▶ Some **other benefits** from using plants include: production of materials for housing, food, forage medicine production and the creation of employment opportunities.

An understanding of the potential and the limitations of phytotechnologies would ensure success when they are applied. Insufficient knowledge and expertise regarding selection of species, distribution and disposition requirements, factors influencing plant growth, as well as public and regulatory acceptance of their use, will cause the use of this technological approach to fail. Each applica-

tion of phytotechnologies involves site-specific considerations and should be evaluated on a case-by-case basis. The developers and proponents of phytotechnological applications must be able to demonstrate environmental performance of the selected technique based on objectives and economic benefits and minimizing potential environmental and human health risks (the latter particularly in cases of phytoremediation applications that are undertaken to clean polluted sites).

The effectiveness in the short and long term of the application of phytotechnologies would also depend on having both broad-based and expert input into their development, adoption, maintenance and monitoring by those utilizing them. The involvement in some cases of local citizens will also ensure their performance and sustainability.

**Specific examples of phytotechnological applications in IWM**

The major goal of applying of phytotechnologies and ecohydrology in IWM is to improve water quality and quantity as well as to stabilize the hydrological cycle. To achieve this, applications of

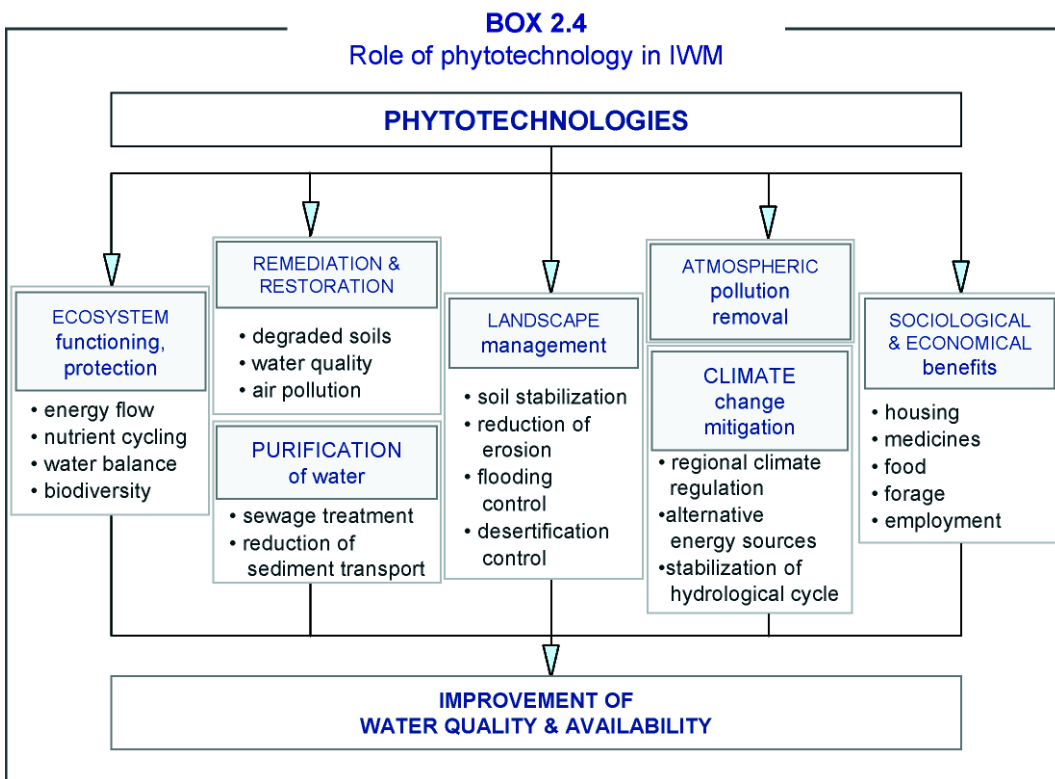

phytotechnologies should cover activities at all spatial levels in the watershed (see chapter 1.C), which include the landscape, land-water ecotone zones, freshwater bodies and estuaries. The most commonly used applications of phytotechnology for management of water resources include the following:

- **phytoremediation of soils** to reduce landscape pollution impacts on fresh waters (e.g., chapter 9.A);
- **vegetation cover management** (forestry and agriculture practices) in order to control the water cycle in landscapes and reduce nutrient leaching and erosion from a catchment (e.g., chapters 9.B, 9.C);
- **ecotone protection and rehabilitation** for reducing diffuse pollution from agricultural lands and others (e.g., chapters 10.B, 11.C);
- **water quality improvement** and eutrophication control through the use of **natural and constructed wetlands** and **floodplains** (e.g., chapters 10.A, 10 C);
- **enhancement of biodiversity** through the growth of aquatic vegetation (e.g., chapters 11.B, 12.C); and
- **production of alternative fuels** or bio-energy production to reduce oil and charcoal use as the main sources of energy mainly in rural areas (e.g., chapters 2.C).

### Socio-economic benefits of phytotechnological applications in IWM

Phytotechnologies are considered as low cost environmentally sound technologies and may provide high environmental efficiency at reduced costs. While applied together in some cases with conventional methods, they can provide socio-economic benefits on their own. For example:

- provision of **alternative sources of energy** (bioenergy), resulting in a decrease of per capita outflows of capital for fossil fuel use;
- **fertilizer** source for agriculture, forestry and bioenergetic plantations;
- production of material for **housing, food, forage and sources of medicine**;
- creation of **employment** opportunities for local residents;
- increase of the **quality of life through** rural development and more livable cities; and
- contribute to the **inflow of capital** resulting from the activities based on the quality of water and environment (e.g., tourism).

#### MAKE SURE TO CHECK THESE RESOURCES:

Guidelines: chapters 1, 4, 5

<http://www.unep.or.jp/ietc/Publications/Freshwater/FMS7/index.asp>

<http://www.unep.or.jp/ietc/Publications/Freshwater/FMS2/index.asp>

<http://www.rtdf.org/public/phyto/bib/default.cfm>

<http://www.itrcweb.org>

<http://www.ec.gc.ca/etad/default.asp?lang=En&n=510541DD-1>

## 2.C. APPLICATION OF ECOHYDROLOGY AND PHYTOTECHNOLOGY FOR WATER RESOURCES MANAGEMENT AND SUSTAINABLE DEVELOPMENT. UNESCO / UNEP DEMONSTRATION PROJECT

Demonstration projects aims at developing, validating and implementing ecohydrology and phytotechnology in integrated watershed management, and are joint UNESCO/UNEP initiatives. Based on the above concepts, demonstration projects endeavour to develop a cost-effective, comprehensive strategy, not only for improving water quality and quantity, but also for meeting local concerns in a given region.

The Pilica River Demonstration Project was designed to mitigate point and non-point sources of pollution entering a river, reduce the risk of toxic algal blooms appearing in a shallow reservoir and converting these threats into opportunities for the regional economy.



Fig. 2.1  
The Pilica River  
(photo: B. Sumorok)

### LOCATION OF THE DEMONSTRATION PROJECT

The Pilica River Demonstration Project is located

in central Poland. It is comprised of a **catchment - river - reservoir** system, including the Pilica Ri-

#### BOX 2.5

#### UNESCO / UNEP Demonstration Project on Ecohydrology and Phytotechnology - location of two demonstration areas in Poland

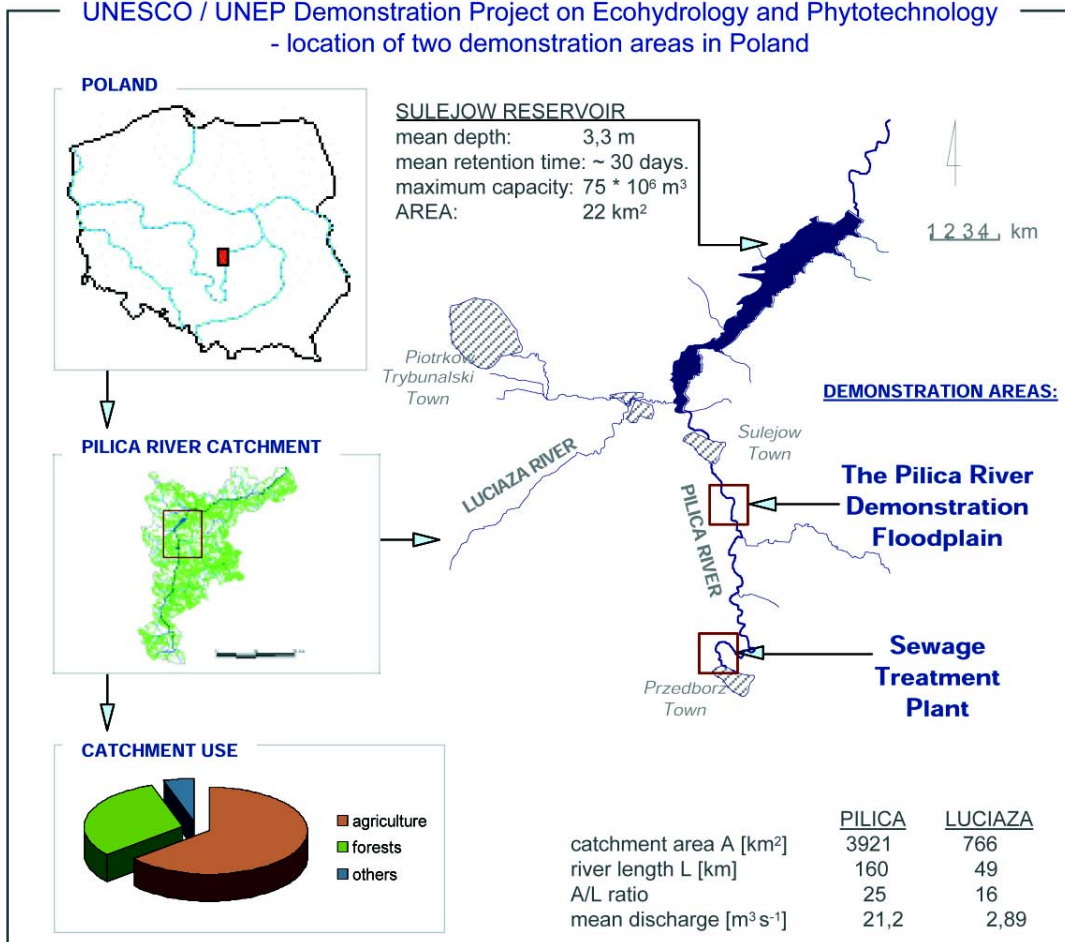

ver (Fig. 2.1) and a lowland reservoir located in its middle reach (the Sulejow Reservoir; Box 2.5). For nearly 30 years the main function of the reservoir has been to supply the City of Lodz (about 800 000 inhabitants) with drinking water. This purpose has lately been restricted because of water quality concerns. It serves now as an optional source of drinking water and recreational area for about 1 million people.

### KEY ISSUES

**Key issues** have been classified into ecological and socio-economic categories (Box 2.6).

<b>BOX 2.6</b> Key issues in the Pilica River catchment
<b>ECOLOGICAL ISSUES</b>
Non-point pollution sources of the river resulting from agricultural use of the catchment
- high nutrient loads transported by the river, especially during flood periods;
point sources of pollution severely impacting water quality of the river;
- unstable and outdated treatment technologies at the sewage treatment plants;
- exceeded chemical and biological standards in the sewage released to the river from the treatment plants;
- eutrophication and periodically increased bacterial numbers in a river;
toxic algal blooms in the reservoir;
- Eutrophication and toxic cyanobacterial blooms restricting use of the reservoir as a drinking water supply and recreational area;
<b>SOCIO-ECONOMIC ISSUES</b>
unemployment ratio over 20%
agriculture development limited by low soil quality
limitation of the development of tourism by low water quality of the Pilica River and the Sulejow Reservoir

### Ecological issues

The Pilica River catchment is a beautiful, picturesque area, with several landscape parks and preserved old forests, as well it has high cultural and historical values. The river itself - although over most of its length has an undisturbed character - it is, however, impacted by **point-sources of pollution** due to unstable and outdated sewage treatment technologies. These affect the chemical and physical components, bacteriology and biotic structure of the river. A large part of the pollution also comes from **non-point sources**, which is derived mostly from agriculture in the catchment (Box 2.5).

The pollution not only effects the quality of the river, but is transported to the Sulejow Reservoir located downstream. Large amounts of the inflowing sediment and nutrients are retained in the reservoir, resulting in eutrophication and the occurrence of **intensive cyanobacterial blooms** during summers. The maximum cyanobacterial biomass observed in 1995 reached 60 mg L<sup>-1</sup> (Tarczynska, 1998). Several studies revealed **cancerous and toxic effects** of the toxins produced in the reservoir by the cyanobacteria (*Microcystis aeruginosa*) (Mankiewicz, Tarczynska, Walter, Zalewski, 2003; see chapter 7.D).

### Socio-economic issues

The area is characterized by a high unemployment rate, locally reaching more than 20%. At the same time agriculture, considered traditionally to be the main income for a large part of the local population, has been limited by low soil quality in a competitive economy.

High value of the region's natural resources could make it a good area for future development of recreation, tourism and eco-tourism. However, there is a need to **improve the water quality** and reduce the occurrence of toxic algal blooms, which reduce the appeal of the area for potential investors and can restrict the development. Another opportunity is development of alternative agricultural production, e.g., **production of biomass**.



## GOAL OF THE PROJECT

The major goal of the project has been to validate application of ecohydrology and phytotechnology for **converting of nutrients** from point and non-point sources of pollution into **biomass and bioenergy**. This is not only to **improve the quality of the environment**, but also to provide additional alternatives for **development of the region and employment**.

## DEMONSTRATION AREAS

The project has been developed in the two demonstration areas (Box 2.5):

- ▶ **The sewage treatment plant in Przedborz Town** (4,000 inhabitants), where treated sewage from the plant has been disposed directly into the river, until now. According to the **phytotechnology approach**, establishment of a **constructed wetland together with a willow plantation** as the final step of treatment, could diminish the impact on the river. Additionally, the biomass produced in the wetland could be utilized as **bioenergy**, and cover part of the energetic needs of the treatment plant, reducing costs of it's maintenance.
- ▶ **Demonstration floodplain of the Pilica River**, where a method for **reduction nutrient loads transported by the river** down to the reservoir was to be developed and quantified. Nutrient retention can be enhanced by two groups of processes: physical ones (intensification of sedimentation by regulation of floodplain hydraulics) and biological ones (uptake of the dissolved fraction by **biomass** through the management of the natural floodplain vegetation communities and patches of planted willow).

## PROJECT IMPLEMENTATION

The implementation of the project has been developed through five parallel lines of action:

- ▶ **research** - providing scientific evidence of the hydrological and biological processes;
- ▶ **development and implementation of technologies** for applying ecohydrology and phytotechnology in the research areas;
- ▶ **Meetings** with local government, stakehol-

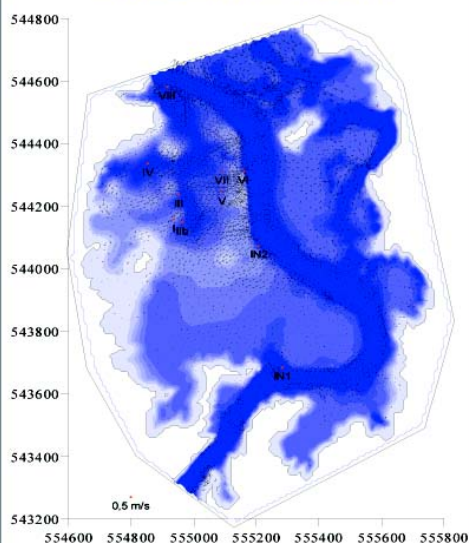

Fig. 2.2  
Sampling of mycorrhizal samples  
on the Pilica River demonstration floodplain  
(photo: I. Wagner-Lotkowska)

- ders and landowners, for dissemination of information and facilitation of implementation;
- ▶ **Training and education** - including primary and secondary schools in the region, national and international university students and young scientists;
- ▶ **Dissemination** of the information and experiences about the project at the national and international levels;

### BOX 2.7

#### Hydraulic model of the demonstration floodplain of the Pilica River



Example of the visualisation of the hydraulic model constructed for the Pilica River demonstration floodplain.

Co-operation with the Department of Hydraulics and Hydrology of Gdansk Technical University and Faculty of Geography and Regional Studies of University of Warsaw (Poland).

(Szydłowski, Magnuszewski,  
Wagner-Lotkowska, unpublished data)

## GENERAL RESULTS

The results of the first year of project implementation include the following:

- ▶ **Development of hydraulic models of the demonstration floodplain**, for optimization of sedimentation processes and nutrient and water retention (Box 2.7);
- ▶ Elaboration of recommendations for **vegetation management** in order to enhance the ability of the system to retain nutrients in biomass.
- ▶ **Elaboration of a draft management plan for a water treatment plant in Przedborz**, including recommendations for both technical upgrades and justifications for a phytotechnological application.
- ▶ **Elaboration of a management strategy for the use of biomass produced in the area.** Following the idea presented in the summary of the UNESCO/UNEP Guidelines (Box 2.8), the strategy should generate a positive socio-economic feedback based on the use and management of environmental resources. The potential for bioenergy production in the region has been estimated using various scenarios of energetic needs.
- ▶ **Increase of knowledge and awareness about ecohydrology and phytotechnology, their application in IWM and benefits for sustainable development in the region**, by training, education and dissemination. Several trained target groups includes local, regional and national authorities, NGOs, stakehol-



Fig. 2.3. Education for primary schools (photo: I. Wagner-Lotkowska)



Fig. 2.4. Extensive planting of willows on the Demonstration Floodplain (photo: I. Wagner-Lotkowska)

ders and landowners, which have been involved in implementation of the project during the latter stages. Another group of activities was aimed at researchers, young scientists, university teachers, students, youth and children, primary and secondary teachers. The outcomes and results of the project have been disseminated during a number of national and international meetings and conferences, by distribution of informative materials and a website written in both Polish and English.

## FUTURE PERSPECTIVES

The results of the first phase of the project implementation show the potential for the application of ecohydrology and phytotechnology measures in the Pilica Region, which has attracted the interest of local and regional authorities. Further development of the project is to be focused on the following aspects:

- ▶ **Continuation** of the tasks developed in the first phase of the project;
- ▶ Preparatory work for implementation of the achievements of the project's first phase at a **larger scale**;
- ▶ Elaboration of a strategy for biomass use for **solving other environmental problems** in cities in the region, such as conversion of polyolefin wastes into energy.

**BOX 2.8**

**Incorporation of socio-economic aspects into constructed wetland planning**

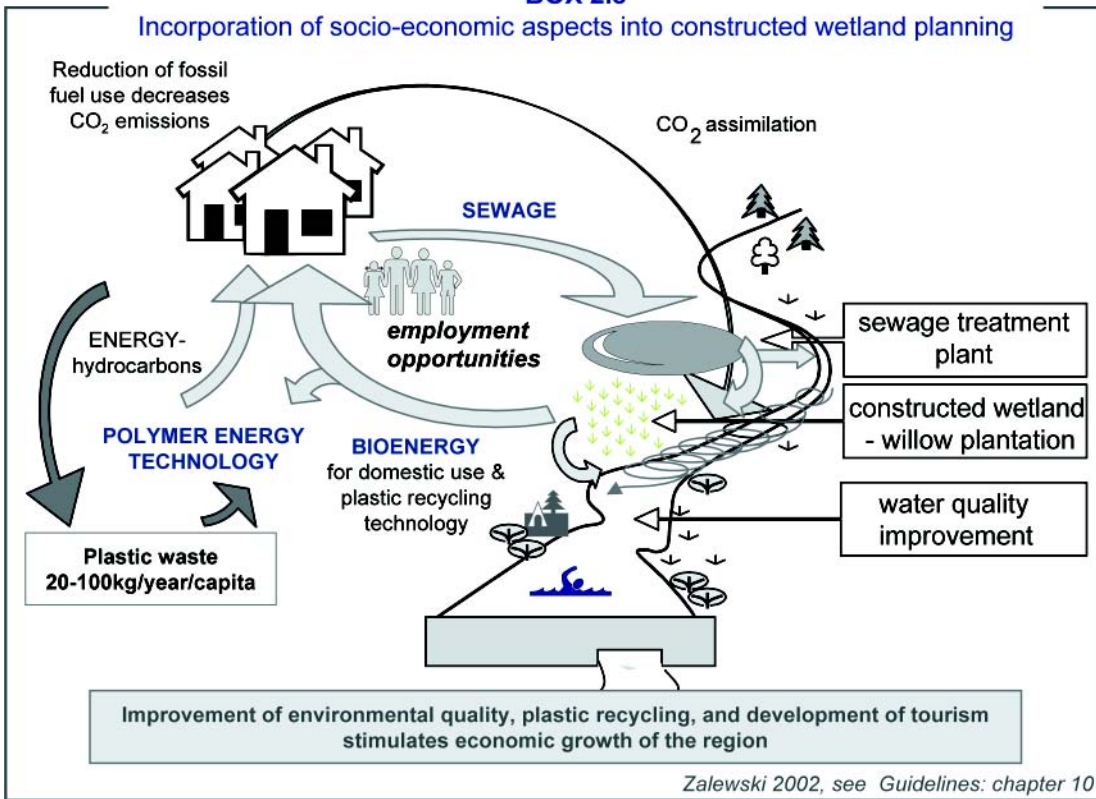

**MAKE SURE TO CHECK THESE RESOURCES:**

Guidelines: chapters 2, 7, 10  
[www.biol.uni.lodz.pl/demosite/pilica](http://www.biol.uni.lodz.pl/demosite/pilica)

### ■ 3.A. WATERSHED

#### WHAT IS A WATERSHED?

Rivers can be seen as veins of a leaf, extending all over a drainage basin up to their divides. When rain falls on a watershed it finally ends up in a river system. A river channel is the lowest point in the surrounding landscape. Its purpose is to convey excess water from a drainage basin, which will include the products of weathering and additional loads of solutes produced by man. This property makes a drainage basin an integrator and its operation is reflected in the quantity and quality of the river run-off.

**Drainage basin (catchment area)** is the area which supplies a river system, lake or reservoir with water. The whole area consists of **smaller sub-catchments** supplying tributaries of the main river and **direct catchments**, which drain straight into a lake or main river (Box 3.1).

The purpose of the river system is to drain catchment areas. Surplus water in the drainage area forms **river run-off**, which is conveyed by a river system. Products of weathering (sediments and solutes) as well as man-generated pollutants, are transported with the water.

#### WHERE ARE THE BOUNDARIES OF A WATERSHED?

The boundary line separating catchments is called a **drainage divide** or **watershed divide**.

A watershed divide is delineated on a topographic

map according to the relief of the landscape. This method helps to determine the **surface catchment**.

In many catchments the area which supplies a river system with groundwater is not coincident with the surface catchment. Ground water may flow from a distant area. In such a case a **groundwater catchment** should be delineated based on an analysis of the groundwater contour lines or piezometric surface.

#### WHY IS A WATERSHED A BASIC UNIT IN IWM?

A drainage basin is the primary unit for water and matter circulation, analysis and planning. In this unit mesoscale water circulation is created from a random and temporally uneven field of atmospheric precipitation. According to the first principle of ecohydrology, which defines the **framework for ecohydrological processes** in IWM, energy flow, water and matter circulation are integrated at a basin scale, as a major unit, and function as a single entity. The mesoscale cycle of water circulation within a basin regulates the coupling of terrestrial and aquatic ecosystems, provides a template for the quantification of ecological processes and creates the template for the application of **ecohydrology and phytotechnologies** in management practices.

**BOX 3.1**  
Surface catchment of a river

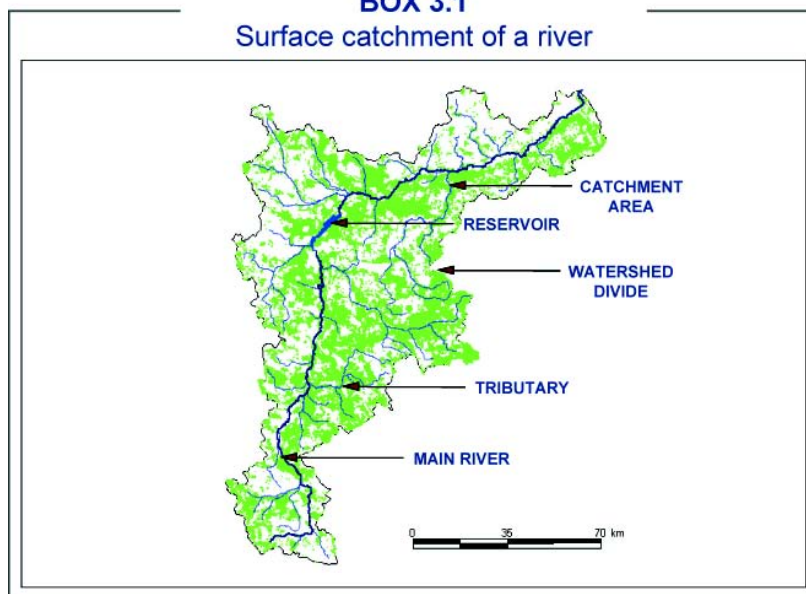

## ■ 3.B. CLIMATE

### WHAT IS CLIMATE?

- ▶ **Climate** is defined as the average of weather variables over relatively long periods of time.
- ▶ **Climate variability** is defined as the range of values that the climate can take over time in a given area.
- ▶ **Climate change** means an alteration of atmospheric processes attributed to human activity, in addition to natural climate variability.

### DOES CLIMATE CHANGE?

According to the most recent assessment of the Intergovernmental Panel on Climate Change (2001), the global surface temperature may increase by between 1,4°C and 5,8°C over the 21st Century as a result of human activities. Not only air **temperature**, but also **precipitation, evapotranspiration, wind speed** and **solar radiation**, are likely to be perturbed due to changes in the chemical composition of the atmosphere. Climate changes are likely to exaggerate **extreme weather fluctuations**.

### HOW DOES IT CHANGE?

The impacts of climate change on hydrology and ecology are usually assessed by defining scenarios for changes in climatic inputs to physical and biological processes. There is a growing demand for credible regional-scale climate scenarios, which are reliant on techniques to downscale from **Global Climate Models (GCMs)** - the principal tools for climate change research.

There is much uncertainty implicit in the choice of GCM, further complicated by the variety of downscaling methods. One of the major policy implications of climate change is that it may no longer be assumed that the future aquatic resources base will be similar to that of the present.

### HOW CAN CLIMATE CHANGE IMPACT ECOHYDROLOGICAL PROCESSES?

Global climate change is expected to affect directly both the **quantity** and **quality of water resources**.

It will affect particular elements of the hydrological cycle, changing river discharges, and hence also water retention times in reservoirs and water levels in lakes. It is predicted that the timing and intensity of **floods and droughts** will also change, which can have serious economic and sociological effects. Since water is the main medium responsible for the export of nutrients and pollutants from catchments, the above processes will alter **nutrient transport patterns** to fresh waters, and hence their physical and chemical parameters.

Due to predicted air **temperature increases**, water temperature and the number of ice-free days will also change. The rate of all physical, chemical and biological processes could be accelerated. Some **species may disappear** or the boundaries of their range could be shifted. All the above processes may seriously affect ecosystem functioning and structure, especially in the case of degraded ecosystems.

### ■ 3.C. HYDROLOGICAL CYCLE

#### WHAT IS THE HYDROLOGICAL CYCLE?

The hydrological cycle is a process of water circulation between the atmosphere, hydrosphere, and lithosphere (Box 3.2). It can be considered at two major scales:

- ▶ **global scale**, where the major elements are the oceans (97%), continents (0,02% as inland waters), and atmosphere (0,001%); and
- ▶ **basin scale (mesoscale)**, where the major elements are water fluxes between the atmosphere, biosphere and lithosphere. Mesoscale water circulation can be considered as the **template for the quantification of fundamental ecological processes**.

#### WHY IS AN UNDERSTANDING OF THE HYDROLOGICAL CYCLE IMPORTANT FOR IWM?

##### Water quantity...

Sustainable water management should take into account the natural water balance that determines the amount of water resources and their availability in time. Hydrological cycle dynamics regulate **the amount of water** in freshwater ecosystems and the **availability of water** in terrestrial ecosystems, which is potentially a limiting factor for primary productivity and hence vegetation development. Therefore, water is one of the major driving forces for ecological processes at

the catchment scale. On the other hand, biological processes can also regulate the hydrological cycle, especially at the mesoscale, by influencing evapotranspiration, evaporation, and the heat and water balances. Therefore, application of phytotechnologies (e.g., increase of water retention in a catchment by management of vegetation cover) can be a useful tool to regulate water circulation in a basin and, consequently, to increase the quantity of water.

From a socio-economic perspective, stabilization of the hydrological cycle by using ecohydrological and phytotechnological measures may reduce the risk of **floods and droughts**.

##### Water quality...

The hydrological cycle forms a template for biogeochemical cycles in a catchment and is linked with processes of **erosion** and **sedimentation**. Water is one of the most important driving forces for material circulation and the primary medium by which nutrients and pollutants flow within landscapes and into most terrestrial and water ecosystems. Therefore, without an accurate estimate of the hydrological cycle elements in a catchment, it is not possible to estimate biogeochemical cycles, the control of which is fundamental for the application of **ecohydrological and phytotechnological measures in IWM**.

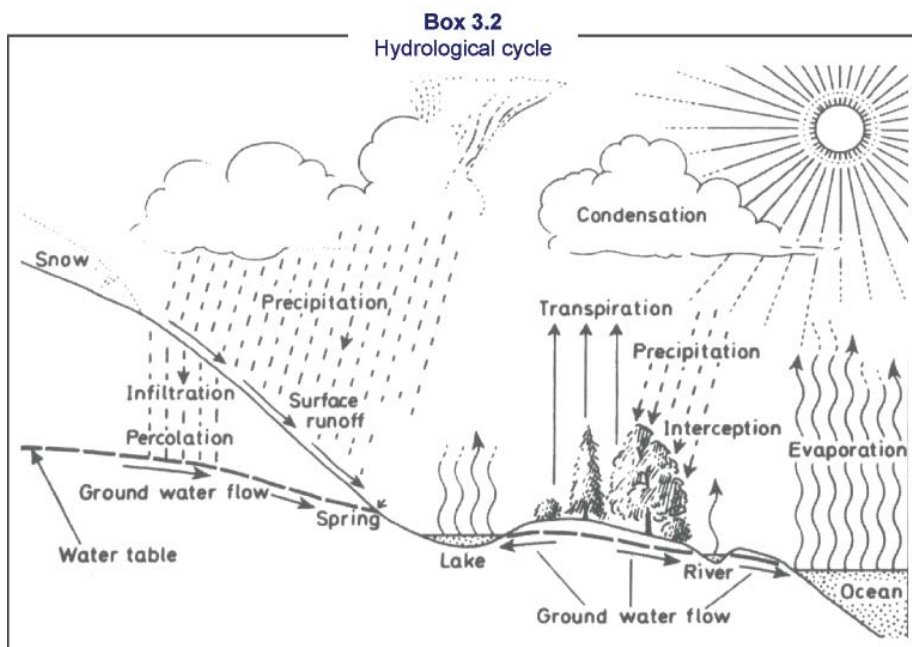

### 3.D. BIOGEOCHEMICAL CYCLES

#### WHAT ARE BIOGEOCHEMICAL CYCLES?

Biogeochemical cycles are the characteristic routes between **abiotic elements** of the environment and its **biotic components** through which **matter circulates**. Matter circulates as particular elements and occurs in the form of **continuously transformed organic and inorganic compounds**. Living organisms need 40 elements to sustain growth and reproduction. The most required **nutrients** include such elements as: carbon, phosphorus, nitrogen, oxygen and hydrogen, of which the last two are usually readily available in most environments.

#### HOW ARE NUTRIENTS TRANSFORMED?

Nutrient transformations in biogeochemical cycles are controlled by two groups of processes:

- ▶ **Abiotic** - geochemical cycles such as: precipitation, diffusion, dissociation and redox reactions.
- ▶ **Biotic** - resulting from the activity of live organisms such as: incorporation of inorganic and organic nutrients into the biomass of plants, grazers and predators or liberation of nutrients in microbiological decomposition.

All the above processes in both terrestrial and freshwater ecosystems are strongly controlled by **solar energy, water and temperature**. Solar energy is assimilated by plants and flows through trophic levels and back to decomposers. Water serves as a medium determi-

ning the «routes» of the nutrients in biogeochemical cycles (e.g., the rate of erosion and nutrient availability for vegetation). Temperature determines the rate of both abiotic and biotic process.

#### Degradation of biogeochemical cycles

Anthropogenic pressure results in degradation of landscapes (e.g., deforestation, unsustainable agriculture and urbanization) and the biotic structure of fresh waters (e.g., river regulation), and thus leads to modification of evolutionarily established biogeochemical cycles.

The above processes open nutrient cycles that results in their increased export from the landscape to fresh waters and diminish the ability of freshwater ecosystems to self-purify, while nutrient enrichment will lead to eutrophication.

#### Role of ecohydrology and phytotechnology

Proper functioning of biogeochemical cycles determines water quality. The main role of **phytotechnology** is to reverse the effect of their degradation by retention of nutrients in vegetation. **Ecohydrology** defines how to optimize the assimilation processes by use of hydrological processes, e.g., for precise distribution of vegetation in a catchment. Therefore, understanding the functioning and factors regulating biogeochemical cycles is fundamental for application of ecohydrology and phytotechnology in IWM.

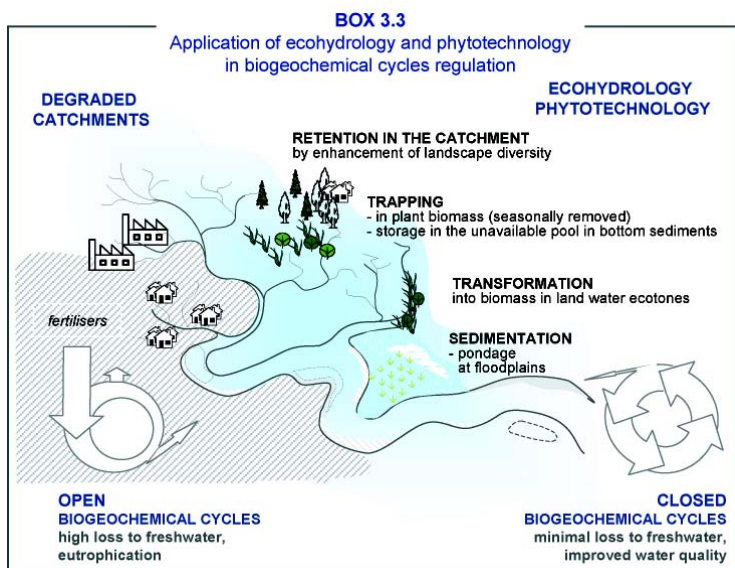

### ■ 3.E. LANDSCAPE STRUCTURE AND VEGETATION COVER

#### WHAT IS A LANDSCAPE?

A **landscape** is the total human environment including the geosphere, biosphere and technosphere. From an **ecological point of view**, it should be considered as a group of biotopes, which are the smallest spatial units of homogenous abiotic conditions (**physiotope**) with a related natural combination of **biota**.

This imposes the approach for **landscape analysis**, which requires a holistic and integrative approach focused on the entirety of biogeochemical processes, such as proposed in the concept of ecohydrology.

#### WHAT ARE LANDSCAPE FUNCTIONS?

- ▶ accumulation of material and dispersion of human - induced energy;
- ▶ receptacle of unsuitable wastes from populated areas and their rendering;
- ▶ filtration of energy, matter and organism flows;
- ▶ resource regeneration and recycling;
- ▶ provision of wildlife refuges; and
- ▶ support for regional settlement and recreation (Mander et al., 1995).

#### WHAT DECIDES LANDSCAPE STRUCTURE?

A landscape is a complex system of elements, which are **static** or **dynamic** in time and space.

- ▶ static elements include forms that are structural in character - **point, line and area elements** distributed homogeneously, heterogeneously or in a patchy way;
- ▶ dynamic elements consist **of biota** reflecting relationships between biotic and abiotic components.

#### UNBALANCED AND BALANCED LANDSCAPES

The **elements** in each class consist of primary or **natural**, and secondary, or **human-made or man-modified**, structures. The unsustainable interaction between these two groups may create an **unbalanced** situation leading to devaluation of landscape processes.

The effect of this interaction is degradation of landscape structure, its fragmentation or homogenization (depending on the land - use system).



Fig. 3.1  
Representation of a tropical Landscape,  
Bogor, Indonesia  
(photo: V. Santiago-Fandino)

Both situations may lead to:

- ▶ increased leak of toxic substances and nutrients to waters;
- ▶ decrease of water retention in river catchments;
- ▶ changes in solar radiation balance; and
- ▶ decline of biodiversity.

Freshwater ecosystems, which are located in land depressions, are good indicators of the quality of neighbouring terrestrial systems.

#### ECOHYDROLOGY & PHYTOTECNOLOGY IN LANDSCAPE MANAGEMENT

**Vegetation** is one of the most important factors **protecting landscapes** and, at the same time, the most sensitive element affected by man's activities. Its role is influenced by: the reduction of forests, changes in species composition and quantitative properties of vegetation cover, land drainage or irrigation, and the degradation of land - water ecotone zones.

Therefore, sustainable **landscape management**, as well as management of **ecotone zones** between a landscape and water, requires a better understanding and regulation of hydrology - biota interactions as proposed in the **ecohydrological** approach and put into practice through the application of **phytotechnologies** as one of major biotic tools.

The goal of sustainable management is to maintain the ecological functions of landscapes under increasing human aspirations and pressures.



### 3.F. STREAMS AND RIVERS

#### WHAT ARE THE STRUCTURAL COMPONENTS OF A RIVER ECOSYSTEM?

**Streams and rivers** are integrated flowing systems that create and maintain aquatic habitats within the structure of their flow as well as on and below their wetted boundaries.

Natural channel evolution is governed by climate, geology, topography, soil and vegetation conditions of a watercourse and watershed. The characteristic regime, or geomorphology, of a natural channel can be defined in terms of the maximum water level contained between its banks, channel width to depth ratio, occurrence of an active floodplain, meander pattern, slope, bed material and bank material.

Streams and rivers are thus open systems characterized by a high level of heterogeneity across a range of spatio-temporal scales (Ward, 1989). Four dimensions are recognized:

- ▶ longitudinal dimension: along the direction of flow from source to estuary;
- ▶ lateral dimension: the system composed of the main channel and floodplain;

- ▶ vertical dimension: the interactions between river water and groundwater in the surrounding area; and
- ▶ temporal dimension: processes such as succession and rejuvenation.

Longitudinally rivers are divided into three zones:

- headwaters;
- transfer; and
- deposition zones (Schumm, 1989).

Riverine habitats are organized hierarchically in a basin context (Frissell et al., 1986) and should be especially considered during restoration projects. The broad spatio-temporal scale of river ecosystems, especially their links and interactions with landscapes, determines the need to view and understand its processes in the larger scale and holistic context proposed, e.g., by ecohydrology concept.

The simplest way to estimate the size of a river is with the stream-order conception (Strahler, 1964). In this system, channels with no tributaries are numbered as order 1. Two channels of order 1 create a channel of order 2, etc.

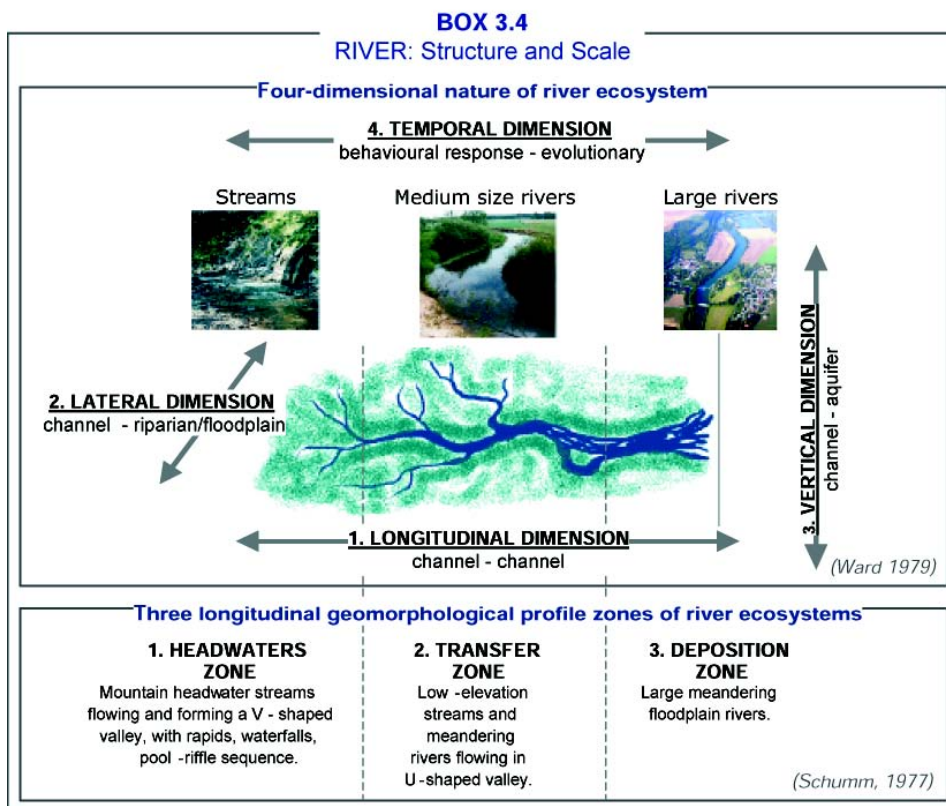

### ■ 3.G. LAKES AND RESERVOIRS

#### WHAT ARE THE DIFFERENCES AND SIMILARITIES BETWEEN LAKES AND RESERVOIRS?

A **lake** is a natural, standing, freshwater or saline water body found on the Earth's continental land masses (Table 3.1).

Man-made **reservoirs**, also called „artificial lakes“, are water bodies with different shapes and sizes that have been constructed by humans by damming a river.

Reservoirs that have been formed by diverting water from a river to an artificial basin are called **impoundments**.

#### FUNCTIONS OF LAKES AND RESERVOIRS

The functions of lakes and reservoirs usually includes:

- production of drinking water;
- fisheries and aquaculture; and
- recreation.

Additionally, reservoirs may also be used for:

- flood prevention;
- retention of storm waters; and
- production of electricity.

Some of the functions require maintaining high water quality.

#### MAN-MADE RESERVOIRS - MANAGEMENT ISSUES

Freshwater management strategies for dams have usually been focused on issues such as flood protection, drought relief, and energy generation. However, catchment degradation resulting in lowering of water quality in reservoirs has lately become an emerging problem. River damming intensifies sedimentation of particular matter and thus nutrient retention within a reservoir. Subsequent recirculation of the matter by the biota and increased productivity leads to so called „secondary pollution“. The worst of these impacts are blooms of cyanobacteria that may produce carcinogenic toxic substances.

#### WHY RESERVOIRS ARE SUSCEPTIBLE TO WATER QUALITY DEGRADATION?

Limnological characteristics of reservoirs make them especially susceptible to the processes of eutrophication. This is because of:

- the high ratio of catchment to reservoir area resulting in high nutrient input;
- high suspended matter sedimentation;
- increase of water retention time; and
- lack of a littoral zone as a consequence of water level changes.

**TABLE 3.1**  
General characteristics of lakes and reservoirs on a global scale

CHARACTERISTICS	LAKES	RESERVOIRS
<b>location</b>	especially abundant in glaciated areas	worldwide, often in areas with a scarcity of natural lakes
<b>shape</b>	generally circular	elongated and dendritic
<b>drainage: surface area</b>	ratio usually <10:1	ratio usually >10:1
<b>shoreline</b>	Stable (except for shallow lakes in semi-arid zones)	usually changing (artificially regulated water level)
<b>water level fluctuation</b>	generally small (except for shallow lakes in semi-arid zones)	can be high
<b>water flushing time</b>	long in deeper lakes	often short
<b>rate of sedimentation</b>	usually slow under natural conditions	often rapid
<b>nutrient loading</b>	variable	usually large
<b>ecosystem succession</b>	slow	often rapid
<b>flora and fauna</b>	relatively stable	variable
<b>water outlet</b>	at surface	variable
<b>water inflow</b>	typically from multiple, small tributaries	typically from large rivers

*modified from UNEP, 2000*

## 3.H. FRESHWATER BIOTA

### PHYTOPLANKTON

Freshwater phytoplankton is the algal component of plankton, which are free-living organisms within aquatic environments. Phytoplankton is represented by prokaryotic cyanobacteria and several groups of eukaryotic algae.

Phytoplanktonic organisms are autotrophs, i.e., they fix solar energy by photosynthesis using carbon dioxide, nutrients and trace metals. They comprise the major portion of primary producers in most fresh waters. Like plants on land, they provide basic food for higher trophic levels such as zooplankton and fish.

Nutrients are necessary for algal development, however, their surplus (especially phosphorus) due to catchment degradation, for example, may lead to formation of blooms that degrade water quality.

#### Cyanobacteria

- filaments or round 3-4  $\mu\text{m}$  diameter prokaryotic cells that can build large dense colonies, 100 to 500  $\mu\text{m}$  in diameter (Fig. 3.2);
- they often form seasonal blooms in late summer in temperate lakes, reservoirs, and seas.
- produce toxic compounds that pose a health hazard to people and animals;
- colonies are not easily ingested by aquatic fauna due to their large size;
- destabilization of a reservoir's hydrological characteristics may reduce cyanobacterial growth.

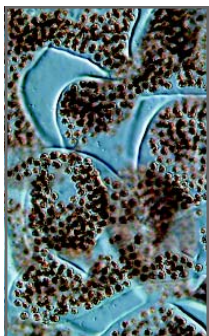

Fig. 3.2  
*Microcystis wesenbergi*  
(photo: P. Znachor)

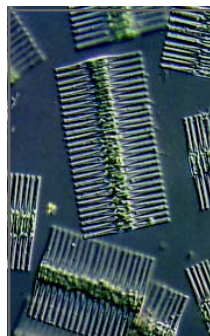

Fig. 3.3  
*Fragilaria crotonensis*  
(photo: P. Znachor)

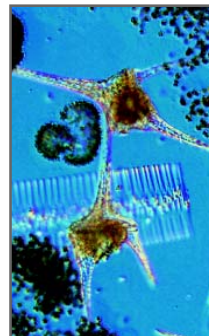

Fig. 3.4  
*Ceratium hirundinella*  
(photo: P. Znachor)

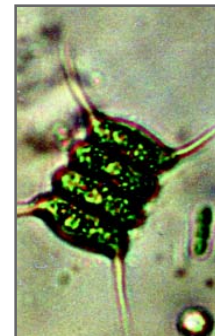

Fig. 3.5  
*Scenedesmus quadricauda*  
(photo: M. Tarczynska)

#### Diatoms

- the most morphologically varied group, including single-cell and colonial species (Fig. 3.3);
- the cells are covered with a cellular membrane hidden inside box-shaped silicate shell;
- unable to move actively, they may have a problem keeping suspended in the water column and that is why they prefer turbulent mixing conditions;
- The dominant group in spring-early summer and in autumn.

#### Phytoflagellates

- possess flagella, which enable migration through a water column;
- some taxa, especially dinoflagellates, cryptomonads and euglenoids, can be temporarily heterotrophic (Fig. 3.4);
- can dominate throughout the year, especially in winter (some dinoflagellates and cryptomonads), or early summer (chrysophyceae);
- may form blooms that sometimes can be toxic, e.g., *Peridinium* sp.

#### Green Algae

- characterized by their grassy green colour, they are among the main sources of food for filtering fauna (Fig. 3.5).
- high diversity of cell size and cellular organization (single cells, colonial and filamentous) and may be both motile and non-motile.
- in fresh water they are dominant, especially during the second half of summer-autumn. Sometimes they may reach bloom density.

## ZOOPLANKTON

Zooplankton occupy a key position in the food webs of lakes and reservoirs, transferring algal primary production to higher trophic levels. Filtering algae and suspended detritus, zooplankton strongly determine the amount and composition of organic matter in the water column.

### Rotatoria

- small organisms (body length <0,2 mm) characterised by different body forms (Fig. 3.6). Among them one can find planktonic, crawling or sedentary genera, while a few are parasites. Rotatoria occur in lakes of different trophic status. Most rotatorians have a carapax, a taxonomic feature;
- they feed on algae, bacteria and detritus while some forms are predatory, e.g., *Asplanchna* sp. (Fig. 3.7). They are characterized by sexual reproduction - they may be partenogenetic or may have separate sexes. In lakes of temperate regions, Rotatoria peak in early spring and/or during autumn.

### Cladocera

- they are the dominant mesoplankton (200 µm - 2 mm in length) in many lakes but are represented by only three genera in the sea (*Evadne* sp., *Podon* sp., *Penilia* sp.);
- herbivorous cladocerans are filter feeders and form the most studied group of zooplankton;
- especially the genus *Daphnia* spp (Fig. 3.8), which is characteristic of mesotrophic lakes;
- small species of Cladocera, like *Bosmina* sp. (Fig. 3.9), may control the microbial food web as top predators;
- very large predatory cladocerans (8-16 mm in length), like *Leptodora kindtii* (Fig. 3.10) or *Bythotrephes* sp., can significantly reduce zooplankton population biomass by 50-60% due to their intensive consumption rates;
- Cladocerans have simple life cycles with partenogenetic reproduction through most of the year with no larval stages. Neonates are morphologically similar to adults.

### Copepoda

- pelagic copepods belong to the two suborders Calanoida and Cyclopoida and occur both in the sea and in fresh waters. Most of the species are herbivorous (mainly Calanoida), although there are also some predatory and parasitic Copepoda.
- different dominance patterns are often observed along trophic gradients: calanoid copepods reach their highest biomass levels in oligotrophic lakes and cyclopoid copepods in eutrophic lakes.
- they are characterized by a complicated life cycle: obligate sexuality, larval nauplius stages and subadult copepodid stages.



Fig. 3.6  
*Keratella taurocephala*  
(photo: A. Wojtal)

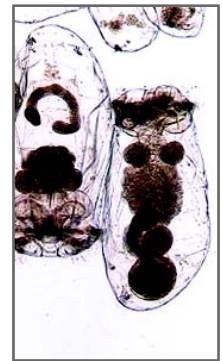

Fig. 3.7  
*Asplanchna* sp.  
(photo: A. Wojtal)

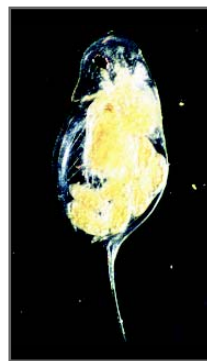

Fig. 3.8  
*Daphnia longispina*  
(photo: A. Wojtal)



Fig. 3.9  
*Bosmina coregoni*  
(photo: A. Wojtal)

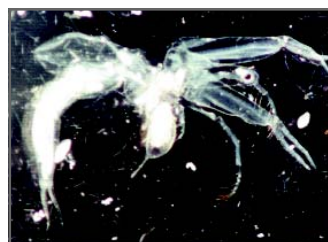

Fig. 3.10  
*Leptodora kindtii*  
(photo: A. Wojtal)

## FISH

Teleost fish are represented by about 20 000 species, which means that nearly half of all vertebrate species are fish. Fresh waters are inhabited by approximately 41% of all fish species (Wootton, 1990). Freshwater fish show multi-adaptations for living in highly variable habitats, utilizing all available food sources by means detritivory via herbivory to insectivory and piscivory (Box 3.2). Many are key major species in lakes and reservoirs, influencing their functioning and dynamics.

In many countries freshwater fish are of great importance as a source of food, but in recent years they also serve as a biomanipulation tool for improving water quality by changing the biotic structure of ecosystems. To achieve this goal, proper fish stock management based on a thorough knowledge of fish biology and ecology is required.

Depending on the position of a given fish species in the trophic structure of an ecosystem, it may play a positive or negative role in regulating water quality. Many piscivorous fish control zooplanktivorous fish reducing grazing pressure on zooplankton, thus can indirectly reduce algal blooms. On the other hand herbivorous fish by consumption



Fig. 3.11  
Pikeperch  
(photo: Z. Kaczkowski)

of macrophytes and algae return readily available nutrients (up to 90%) to water and intensify algal blooms.

To promote a strong and vital population of fish species favourable for lakes and reservoirs, one can utilize the inherent properties of the ecosystem, e.g., the dependence of spawning success of given fish species on the availability of spawning grounds, which in nature is highly influenced by the hydrological regime. Water level manipulation in a reservoir in order to regulate fish spawning success is a good example of an activity based on this principle (Zalewski et al., 1990).

**TABLE 3.2**  
Major trophic categories in fishes

<b>DETRITIVORES</b>	e.g., <i>Tilapia</i>
<b>SCAVENGERS</b>	e.g., <i>Anquilla</i>
<b>HERBIVORES</b>	Grazers (e.g., <i>Plecostomus</i> ) Browsers (e.g., <i>Ctenopharyngodon</i> ) Phytoplanktivores (e.g., <i>Tilapia</i> )
<b>CARNIVORES</b>	<b>Benthivores</b> Selecting relatively small prey (e.g., <i>Gasterosteus</i> ) Disturbing and then selecting prey (e.g., <i>Sufflamen</i> ) Picking up substrate and sorting prey (e.g., <i>Lethrinops</i> ) Grasping relatively large prey (e.g., <i>Balistes</i> ) <b>Zooplanktivores</b> Filter feeders (e.g., <i>Engraulis</i> ) <b>Particulate feeders</b> Aerial feeders (e.g., <i>Toxotes</i> ) <b>Piscivores</b> Ambush hunter (e.g., <i>Cottus</i> ) Lurers (e.g., <i>Lophius</i> ) Stalkers (e.g., <i>Esox</i> ) Chasers (e.g., <i>Salmo</i> ) Ectoparasites (e.g., <i>Exodon</i> )

modified from Wootton, 1990

### ■ 3.1. ESTUARINE AND COASTAL AREAS

#### WHAT ARE ESTUARIES AND COASTAL AREAS?

Estuaries are commonly defined as areas where rivers discharge into the sea. Based on Pritchard's (1967) definition, Day (1980, 1981) considered „an estuary as a partially enclosed coastal body of water which is either permanently or periodically open to the sea, and within which there is a measurable variation of salinity due to the mixture of sea water with fresh water derived from land drainage“. However, this „hydrological“ definition must include the more „biological“ approach suggested by Perillo (1995), that also considers estuaries as being responsible for „sustaining euryhaline biological species for either part or the whole of their life cycle“.

According to water circulation patterns, estuaries can be classified as salt wedge estuaries, partially mixed estuaries, well-mixed estuaries, and fjord - type estuaries (Box 3.5). Salt wedge estuaries occur when circulation is controlled by a river that pushes back the seawater. Partially mixed estuaries, usually deeper estuaries, have a tidal flow: salt water is mixed upward and fresh water is mixed downward. Well-mixed estuaries are frequently shallow, have strong tidal mixing and reduced river flow resulting in vertical homogeneous salinity. Fjord-type estuaries are deep and have moderately high river input and little tidal mixing. Estuaries are commonly subdivided into upper,

middle and lower areas. The upper estuary includes most of the freshwater section, although the effects of tides are still observable. It is an area where riparian vegetation is abundant. This vegetation constitutes a buffer zone, „controlling“ nutrient inputs into an estuary, thus representing a particularly important target for application of phytotechnology. The middle estuary is a transition area in terms of salinity (mainly brackish water) and vegetation. The lower estuary is characterized by a marine influence.

The coast is where land meets the sea. However, as in estuaries, land and ocean processes change this line over time and space, affecting the area considered as coastal.

#### WHY ARE ESTUARIES AND COASTAL AREAS IMPORTANT?

The dynamic nature of estuaries forms the basis of a very complex food chain based on high primary and secondary productivities

Estuaries are perceived as highly productive ecosystems because they are often nutrient rich and have multiple sources of organic carbon to sustain populations of bacteria and other, heterotrophs. These sources include riverine and waste inputs and autochthonous primary production by vascular plants, macroalgae, phytoplankton and benthic microalgae (Cloern, 1987).

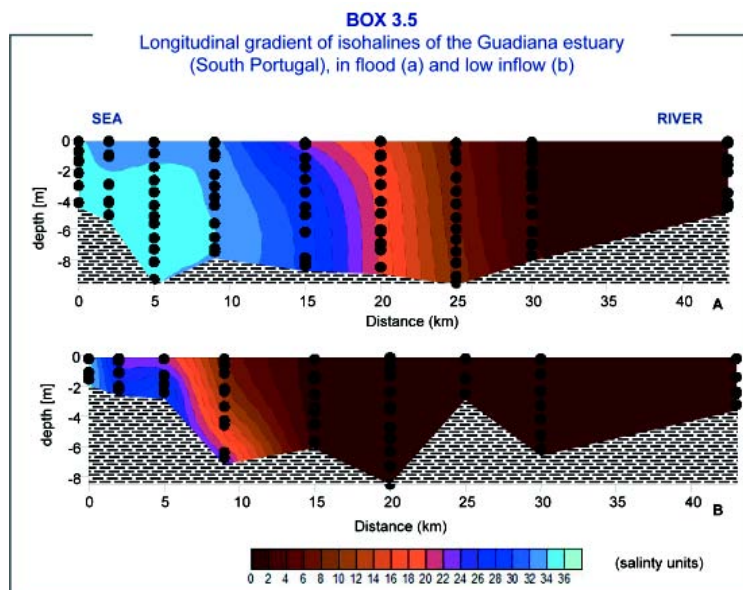

Sediments in the water column, of organic and inorganic origins, can be trapped in a strong upstream bottom flow and forced into the Maximum Turbidity Zone (MTZ). This occurrence affects the structure and functioning of the microbial community, may be limiting to photosynthesis (suspended particulate matter  $> 50 \text{ mg L}^{-1}$ ), contributes to the increase of heterotrophic processes and results in the degradation of organic material, what may lead to depletion of oxygen concentrations. In this zone the transition between freshwater and marine environments occurs. Phytoplankton and bacterioplankton transported down a river will experience salt stress. The freshwater microbial population will lyse and die in this zone.

The composition and spatial distribution of groups of organisms like phytoplankton, zooplankton and benthic invertebrates in estuaries are primarily regulated by salinity and only secondarily by habitat factors, such as sediment structure and depth. Due to their ability to osmotically regulate, fishes are less affected by salinity changes.

Estuaries are also important nursery areas for several invertebrate and fish species. Protection against predators and loss by outwelling currents increases success of larval development and recruitment. River discharge and the consequent river plume, associated with tides, export estuarine nutrients and organisms to coastal areas, enhancing coastal food web dynamics, supporting coastal fisheries and contributing to global ocean productivity.

The structure, broad range and biodiversity of coastal habitats provides a large number of ecological tools and services, such as storage and cycling of nutrients, filtration of pollutants from inland freshwater systems, and protection from erosion and storms. Coral reefs, mangroves, tidal wetlands, seagrasses, estuaries and a variety of other habitats, each provides its own distinct goods and services and faces different pressures. Human modification on shorelines changes currents and sediment loading, affecting coastlines and habitats in some areas.

### WHY ARE ESTUARIES AND COASTAL AREAS CONSIDERED SUSCEPTIBLE?

Many coastal areas are ecologically productive, biologically diverse and climatically and physically attractive and, therefore, are preferred places for the settlement of human populations. Thus, estuaries and coastal areas became the final receptacles of innumerable human and natural factors from land, riverine and oceanic origins.

In the last century, development of cities with millions of people on estuarine margins contributed to the massive destruction of vegetation cover and other habitats. Cumulatively, construction of river diversions (barrages, dams, etc) aimed to provide enough fresh water for human consumption and uses, affects water quality and quantity in estuaries and coastal areas. This human migration to the coast occurred both in developed and developing countries. The resulting stress has become apparent as populations increase, watersheds are deforested and fisheries are over exploited.

Considering the expected human population growth and the increasing need for food, water and space, pressure on estuaries and coastal areas will continue to rise. The consequences could be aggravated under predicted global changes and sea-level rise scenarios.

### WHAT FACTORS INFLUENCE ESTUARIES AND COASTAL AREAS?

Estuaries and coastal areas are affected by both continental and oceanic factors, from exogenous and endogenous origins. As noted above, continental (land and river) originating factors and processes (e.g., run-off, changes in riverine discharges, changes in agricultural practices, etc.) affect estuaries and coastal areas. Moreover, oceanographic factors and processes (e.g., longshore or upwelling currents) also influence water characteristics and affect coastal biological communities and sediment composition and distribution. Endogenous fluctuations in estuarine and coastal communities are expected, for example, as a result from seasonal reproductive cycles. Exogenous impacts caused by anthropogenic activities (e.g., water canalization, pollution, destruction of riparian and salt-marsh vegetation or construc-

tion of piers) influence water quality, quantity and circulation and modifies habitats, affecting the basic structure of species organization in estuarine and coastal ecosystems (Box 3.6).

**WHY DO WE NEED A STANDARDIZED MANUAL FOR ECOHYDROLOGICAL AND PHYTOLOGICAL APPLICATIONS IN ESTUARIES AND COASTAL ZONES?**

Implementation and development of mitigation and restoration techniques based on ecohydrology and phytotechnologies can provide an adequate basis for the integrated and sustainable development and management of estuaries and coastal areas. These concepts use intrinsic characteristics and processes of ecosystems to solve ecological problems. This is accomplished by increasing the natural response of a system and, by doing that,

increasing the capacity to absorb impacts and their consequences.

However, application of these management techniques needs an in-depth knowledge of a system's functioning and the technical skills to make interventions as precisely as possible. In estuaries and coastal areas the complexity of processes and factors involved adds an extra difficulty to the application of these techniques. Basic to the general application of ecohydrological and phytotechnological solutions to estuaries and coastal areas is the need for harmonization of sampling methods, sample processing and analysis of information, as proposed in this manual. This will allow comparisons and exchange of ecohydrological and phytotechnological successful solutions between different estuaries and coastal areas.

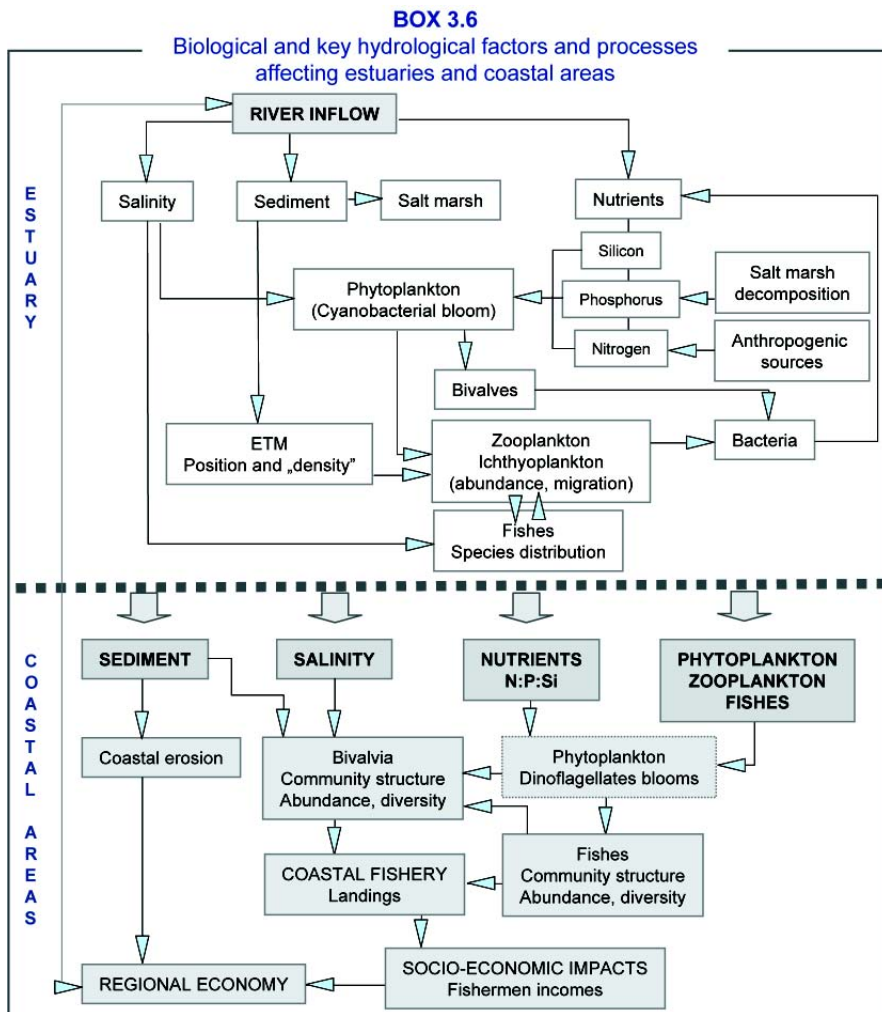





## PART TWO: SURVEYS & ASSESSMENTS



## 4.A HOW URBANIZATION AND INDUSTRIES INFLUENCE WATER QUALITY

Quantification of pollution is necessary for evaluation of environment quality and elaboration of a successful strategy for water quality improvement. Reduction of threats resulting from pollution is always the first step to implement ecological measures in IWM.

The objective of this chapter is to:

- ▶ introduce possible treats resulting from the impacts of urbanization, industrialization and agriculture;
- ▶ give a review of the assessment procedures for point and non-point pollution and identification of „hotspots“ in a catchment.

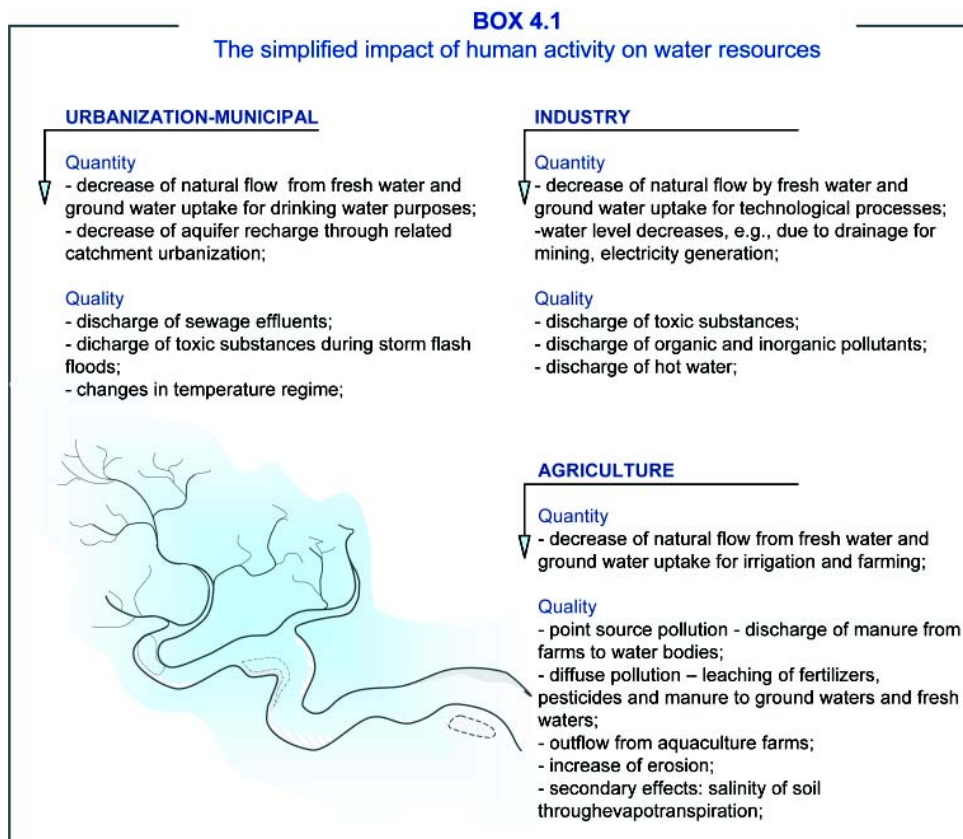

Fig. 4.1  
Urban sprawl often creates poverty belts that heavily impinge on water quality (photo: V. Santiago-Fandino)

### IMPACT OF URBANIZATION, INDUSTRIALIZATION AND AGRICULTURE ON WATER RESOURCES

In the next decades, water shortages resulting from both a lowering of water quantity and quality will be the most urgent problem for 80% of the world’s population. Development of agriculture, industry and urbanization will result in increasing water use, generate more pollutants from both municipi-

pal and industrial uses of water, and contribute to the decline of water resources quality. This may result in the limitation of water resource use by people living downstream, as well as very often degradation of the whole basin-river-reservoir system occurs. Box 4.1 presents an overview of the key sources of pollution impacting fresh waters.



**TABLE 4.1**  
Potential influence of sewage outflow on freshwater quality.

POINT SOURCE POLLUTION										
	hydrological regime	temperature regime	nutrients (p;n)	BOD	suspended solids	heavy metals	toxic hydrocarbons	salinity	acidity	pathogens
<b>Municipal sewage</b>	+++	++	+++	+++	+++	++	+	++	++	+++
<b>Storm water</b>	+++	++	+++	+++	+++	+++	+++	++	++	+
<b>Industry</b>										
Mining	+++	+	+	+	+++	++	+	+++	+++	-
Power plant	+++	+++	-	-	-	+	-	-	-	-
Refinery	+	+	+	+++	+	-	+++	+	+	-
Metallurgy	++	++	-	-	+	++	+	++	++	-
Pharmacy	+++	++	-	++	+	+++	++	+	+	-
Chemical	+++	++	+	++	+	+++	+++	+	+++	-
Textile	+++	++	+	++	++	+++	+++	++	+	-
Food industry	+++	++	+++	+++	+++	-	+	+	+	+++
<b>Agriculture</b>										
Animal farm	+	+	+++	+++	+++	-	-	+	+	+++
Large fish farm	+	+	+++	+++	+++	-	-	+	+	+++

NON-POINT SOURCE POLLUTION (DIFFUSE POLLUTION)										
	hydrological regime	temperature regime	nutrients (p;n)	BOD	suspended solids	heavy metals	toxic hydrocarbons	salinity	acidity	pathogens
<b>Agriculture</b>										
Natural fertilizers	-	-	+++	+++	++	-	+	+	+	+++
Artificial fertilizers	-	-	+++	+	-	+	+	++	++	-
Pesticides	-	-	-	-	-	+++	+++	+	+	-

Risk /influence	+++ HIGH	++ MEDIUM	+ LOW	- NONE
-----------------	----------	-----------	-------	--------

## IDENTIFICATION OF POTENTIAL IMPACTS ON FRESHWATER QUALITY

The first step in the assessment of human impacts on freshwater resources requires identification and quantification of the impacts of major past, ongoing and planned projects (activities) in a catchment. This allows for the recognition of potential pollutants in the basin.

Table 4.1 helps to check the potential risks in a catchment. The following three steps are proposed to

optimize the evaluation procedure for pollution risk assessment at a catchment scale:

- ▶ screening – identification of hot spots (map-study & questionnaires);
- ▶ direct assessment of impacts (field study); and
- ▶ quantification of problems (laboratory assessment and timing of monitoring).

## SCREENING

The screening for identification of „hot spots“ can be done based on map information, statistical analysis and the use of a questionnaire.

### What are the main objectives of screening?

- ▶ analysis of the distribution of activities that affect water quantity and quality at the catchment scale;

- ▶ identification of potential pressures;
- ▶ identification of „hot spots“ and elaboration of guidelines for further assessment; and
- ▶ integration of the information at the catchment level.

### What issues should be identified?

- ▶ **water demand** by agriculture, municipal and industrial users:
  - **daily uptake** ( $\text{m}^3 \text{ day}^{-1}$ ) can be estimated using information from the water supply system or surface/groundwater usage;
  - **if there is no water supply system** - water demand should be calculated by multiplying the number of people and animals by average consumption values;
- ▶ **Potential impacts on water quality:**
  - information about sewage **outflow and sewage treatment** in a catchment should be collected;
  - **if there is no quantitative data**, it can be assumed that sewage outflow equals water use in a catchment,
  - collect information about local **industries**, including planned and implemented projects and estimate their impact (Table 4.1);
  - collect information about large **farms** and aquaculture farms;

**TABLE 4.2**  
The global change in water consumption (from 1950 to 2000)

	1950		1980		1990		2000	
	$\text{km}^3 \text{ y}^{-1}$	%	$\text{km}^3 \text{ y}^{-1}$	%	$\text{km}^3 \text{ y}^{-1}$	%	$\text{km}^3 \text{ y}^{-1}$	%
<b>AGRICULTURE</b>	1130	82,7	2290	69,0	2680	64,9	3250	62,6
<b>INDUSTRY</b>	178	13,0	710	21,4	973	23,6	1280	24,7
<b>MUNICIPAL</b>	52	3,8	200	6,0	300	7,3	441	8,5
<b>RETENTION/HYDROPOWER</b>	6	0,5	120	3,6	170	4,1	220	4,2
<b>Total</b>	<b>1366</b>	<b>100</b>	<b>3320</b>	<b>100</b>	<b>4130</b>	<b>100</b>	<b>5190</b>	<b>100</b>

(after Shiklomanow, 1993)

**TABLE 4.3**  
The consumption of water in litres per capita per day

<b>Developing countries without access to piped water</b>	<b>Countries with access to a water supply system or effective private well</b>	<b>Countries with concentrated water supply system and introduction of water taxes (water price)</b>
50 - 150	200-300	120-160

- calculate the number of cows, sheep and pigs per 100 ha of agriculture land and
  - identify regions with high **impermeable** areas, especially in urbanized regions.
- ▶ Make aggregations of your information and mark „hotspots“ on maps of 1:50 000 or 1:100 000 resolution for catchments smaller than 100 km<sup>2</sup>, and 1:500 000 for catchments greater than 100 km<sup>2</sup>.

### DIRECT ASSESSMENT OF IMPACT

After identification of „hotspots“ the assessment should be continued in the field according to the following steps:

- ▶ establishing **monitoring stations**:
- for **point source pollution** set at least three stations, located at:
    - outflow of sewage;
    - 100-1000 m upstream of the inflow; and
    - 100-1000 m downstream depending on river width.
  - for **diffuse pollution**:
    - at least two stations should be chosen based on a land-use map and for river sections of between 10 to 50 km.
- ▶ as a first step, conduct simple field **measurements** at the identified stations at times of low and high discharge and taking into account the timing of sewage discharge:
- **physical measurements** such as: temperature, O<sub>2</sub> concentration, pH, conductivity, salinity;
  - **preliminary** chemical measurements should be considered;
  - use of **bioassessment** methods that will give an indication of the possible toxic effect of the sewage inflow (for more information - see chapter 7.D);
  - use **biomonitoring** methods (e.g., macroinvertebrates, macrophytes, fish) to check the effect of sewage inflow on a river ecosystem (for more information - see chapter 6.A);
- ▶ **compare the data** for upstream and downstream stations. If differences are greater than 20% in the measured values,

contacting a professional laboratory to focus on the problem should be considered.

*The timing of monitoring is important, especially if you have information about illegal sewage inflows and stormwater pollutants (dilution effects alter very high concentrations of pollutants).*

### QUANTIFICATION OF THE PROBLEM

The preliminary issues identified during the direct assessment of impacts should be further specified by chemical analysis made in a professional laboratory. Water samples for laboratory study (1-5 litres) should be collected at each study station.

- ▶ the water should be taken from the **main course** of a river. If the river is more than 10 m wide, an integrated sample should be collected by mixing equal volumes of water from every 10-20 m of the cross section;
- ▶ **transport** the samples to the laboratory or use field equipment to make analyses
- ▶ standardize the system; and
- ▶ the basic **parameters** that should be determined include: BOD<sub>5</sub>, Total Suspended Solids (TSS), Organic Suspended Mater (OSM), Coliform index, NH<sub>4</sub>-N, NO<sub>2</sub>-N, NO<sub>3</sub>-N, N tot, PO<sub>4</sub>-P, P tot, TOC;

To quantify the impact of pollution on water quality, compare the obtained data with data from non-impacted (reference) sites. The data can be compared to regional standards for water quality.

To have a complete picture for formulating a management strategy and identification of „hot spots“ in the catchment, aggregation of all the above information can be made by using one of the following systems:

- ▶ GIS (see chapter 4.B);
- ▶ hydrochemical profiles of a river; and
- ▶ use of water quality indexes.

## 4.B. HOW TO ASSESS LANDSCAPE IMPACTS ON WATER QUALITY

A landscape is the framework for all biogeochemical and ecological processes. Its structure defines the rate of water and chemical exchanges between land and water ecosystems in catchments and species biodiversity. All these factors determine the self-regulating potential of ecosystems and their resilience to human impacts. This chapter presents basic methods of landscape assessment using aerial photography and remotely sensed imagery in conjunction with GIS technology for estimating the rate, direction, and possible impact of landscape changes on natural resources, such as water and biodiversity.



Fig. 4.2  
The Lubrzanka River Catchment  
in the Swietokrzyskie Mountains of Poland  
(photo: Department of Applied Ecology)

### HOW ARE LANDSCAPES ASSESSED?

From the point of view of protection and management of natural resources it is important to identify and quantify the following landscape structures (Table 4.4):

TABLE 4.4

Role of various structures in a landscape

STRUCTURE TYPE	FUNCTION IN A LANDSCAPE
<b>built-up areas</b>	create impermeable surfaces in the catchment and act as a pollution source, and a place for humans to expand
<b>agricultural lands</b>	are sources of non-point pollutants and the cause of biodiversity loss
<b>linear anthropogenic structures</b>	source of pollution and also participate in landscape fragmentation
<b>meadows</b>	are buffers of medium effectiveness against pollutants
<b>woods and forests</b>	efficient structures regulating rate and mode of flow of water and chemicals through a landscape
<b>land / water transition zones</b>	regulate the exchange ratio of water and nutrients between water and terrestrial systems
<b>water bodies</b>	act as both a recipient of pollutants and as a tool for reduction of nutrient content in ground water

One of the most efficient methods for identification of these areas, and therefore estimation of their role in water and nutrient circulation, is **teledetection**, a method based on recording, visualization and analysis of electromagnetic radiation. Teledetection incorporates classic aerial photography, based on visible light, and recording and visualization of other parts of the electromagnetic spectrum. The type of electromagnetic radiation used for analysis of landscape structures influences the type of information gained and, therefore, one's ability to interpret data - **photointerpretation** (Table 4.5).

### HOW ARE LANDSCAPE STRUCTURES IDENTIFIED ON AERIAL PHOTOGRAPHS?

Aerial photography provides large amounts of information about the area of interest including: physical profile, freshwater distribution and its quantity and quality, distribution and biomass of vegetation and characteristics of human impacts. There are, however, two points, that must be emphasized:

- ▶ to find and properly interpret the information, **direct observations** in the landscape have to be carried out; and
- ▶ **knowledge** about an area has to be obtained and a clear goal of the survey has to be set prior to the analysis of photographs.

**TABLE 4.5**  
Types of electromagnetic radiation used for landscape assessment.

<b>RADIATION TYPE</b>	<b>WAVE LENGTH [m]</b>	<b>OPTIMAL USE</b>
<b>gamma</b>	$<10^{-11}$	for geological purposes - detection of ores, e.g., thorium, potassium, uranium
<b>ultraviolet</b>	$10^{-8} - 4 \cdot 10^{-7}$	mostly for receiving pictures comparable with classical photography, also for detecting objects characterizing spontaneous or triggered luminescence
<b>visible light</b>	$4 \cdot 10^{-7} - 7 \cdot 10^{-7}$	i) grey scale photography: - orthochromatic – sensitive to all spectrum of visible light except red light - orthopanchromatic – sensitive to all colours - superpanchromatic – with increased sensitivity to red light ii) colour photography - classical - multispectral – allow precise colour differentiation (for analysis of vegetation types, water pollution, etc.) the most popular type of aerial photography (low cost, easy interpretation) analysis of land geology and morphology, changes in shapes of river channels, estimation of extent of different areas, plant cover and biomass analysis, calculation of river discharges, crops, erosion rate, etc.
<b>infrared</b>	$7 \cdot 10^{-7} - 3 \cdot 10^{-4}$	precise vegetation cover and soil type analyses, identification of water in the landscape [diminishes shade effect]
<b>Medium and long wave infrared</b>	$3 \cdot 10^{-4} - 10^{-2}$	mostly night pictures – analysis of land structure, especially in arctic regions and volcanic areas, detection of structural anomalies in land geology, estimation of forest conditions, fire risk, in hydrology: analysis of soil moisture, ice cover development, influence of urbanization and industrialization on water pollution, and finally localization of oceanic currents
<b>microwaves</b>	$10^{-2} - 3 \cdot 10^{-3}$	analysis of meteorological phenomena
<b>radar detected radiation</b>	$7,5 \cdot 10^{-3} - 1 \cdot 10^{-1}$	cartography, geological studies, topography analyses [slopes], hydrology: analyses of soil moisture, drainage structure, snow and ice cover

**Topographic profile**

The best source of information about the physical profile of the land is a stereoscopic picture. Analysis of such pictures is possible only with a stereoscope. With some experience you may also try to identify some landscape structures on common photographs. Some of the forms will be easily analyzed and quantified on large-scale pictures [1:50 000], while some require use of smaller scales, like 1:10 000. In some cases, guides for identifying landscape forms maybe useful.

**Forests, woodlands, bushes**

Identification of woodlands is possible as they differ from the background by their colour and grainy structure. Species identification may be conducted on the basis of the separation of single trees and their shadows.

In temperate climates, forests are composed of coniferous and deciduous species. On a photograph the difference between the groups is sometimes visible as **differences in colour brightness** - coniferous forests are darker and the **size of the grains**, reflecting the heads of trees, for conifers are smaller (Box 4.2).

**BOX 4.2**

**How are deciduous and coniferous forests identified?**

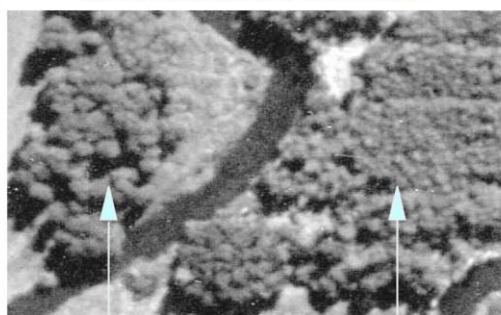

**bigger grains**  
reflects bigger heads  
of deciduous species

**smaller grains**  
are usually indicators  
of conifers species

Also helpful in woodland identification is species phenology. In early spring deciduous trees are leafless. That allows not only for easy differentiation of forests, but makes analysis of the land structure easier. Identification of deciduous and coniferous trees is also easy with photos taken in autumn. For the purposes of forest identification, the most useful are pictures at a medium scale of up to 1:20 000.

**Meadows**

They are recognizable as dark-gray or dark-green areas sometimes having a cloudy texture. After grass harvesting a picture may be different with very strong visible strips, the effect of using harvesting equipment (Box 4.3).

**Arable land**

On aerial photos arable land is clear and brighter in colour, especially during summer months, and is characterized by a specific texture reflecting equipment use. Unfortunately, crop analysis is one of the biggest challenges in photointerpretation. It requires very detailed study of the brightness indicator of different crops on photos taken at particular times of the year.

**Urban areas**

Aerial photography is one of the most valuable sources of information about human settlement. In the case of villages, the most important pro-

erties are: shape, number of farms, building density or, for long-term documentation, also the rate of development as a result of interactions between a settlement and surrounding environment. In the case of towns these interactions are expressed by the arrangement of streets. History and functions of the city may be deduced from the distribution of buildings of different sizes and uses.

**IMPORTANT PARAMETERS - QUANTIFICATION OF INFORMATION**

**How is the area of objects measured?**

The area of objects may be measured directly on the picture if the topographic profile of the land is not very diversified. This is possible using a planimeter, but first the scale of the picture has to be calculated (Box 4.4). Because there are picture deformations, increasing from the centre to the edge, the most accurate estimations may be conducted only for objects situated in the centre.

**How do you measure lengths?**

On pictures of areas showing small elevation differences (up to 100 m) lengths may be measured directly with a ruler. If the lines are curved, the easiest way is to divide them into straight sections and to measure each separately. An alternative method is to use a curvometer. Very small objects require application of a Brinell magnifying glass or Brinell microscope.

**BOX 4.3**

**How are meadows and pastures identified?**



pasture

semi-natural  
meadows located in  
river valleys



**How is patchiness estimated?**

Patchiness is related to the average patch size (APS) in a chosen fragment of landscape:

$$APS = \frac{Sf}{n}$$

where Sf = area of the landscape fragment and n = number of patches.

To calculate the temporal changes of patchiness we need only to modify the equation:

$$\Delta APS = \frac{Sf}{n_1} - \frac{Sf}{n_2}$$

In this case n is the number of patches located on area, Sf, or patches with particular characteristics like woods, meadows, etc (Chmielewski, 2001).

**How is ecotone density estimated?**

Ecotone density is simply calculated as:

$$D = \frac{L}{S}$$

where: D = ecotone density, L = ecotone length and S = analyzed area.

Then the long-term change in density of transitional zones is calculated as:

$$\Delta D = \frac{100 \left( \frac{L_1}{S} - \frac{L_2}{S} \right)}{\frac{L_2}{S}}$$

where ΔD = indicator of density change in transitional zones [%], L<sub>1</sub> = initial length of the transitional zones, L<sub>2</sub> = final length of transitional zones, and S = area of analyzed land (Chmielewski, 2001).

**BOX 4.4**  
How is the scale of the picture determined?

Aerial photos should always be compared with maps of the area.  
The following equation can be used:

$$\frac{l}{m_p} = \frac{l_m}{L_m + m_m}$$

where:  
l – length of the line on the picture (p) and on the map (m)  
m – denominator of the scale of the picture (p) and on the map (m)

*(Czerniak et al., 1999)*

**BOX 4.5**  
How are threats identified?

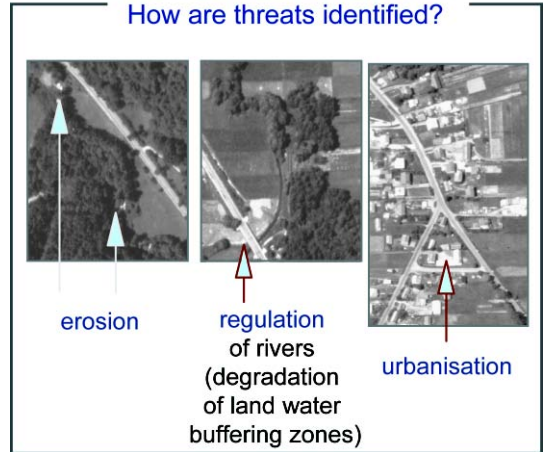

**What are the sources of data error?**

Measurements based on photographs are not always accurate. There are the number of factors that are prone to error, which, if necessary, should be corrected mathematically.

The most important sources of inaccuracy are related to:

- photo slope (can be ignored if less than 3°);
- large elevation differences;
- lack of precision in identification of object borders;
- area deformation caused by cameras; and
- scale of the picture.

**IDENTIFICATION OF ENVIRONMENTAL THREATS**

At the landscape level there are several signs of loss of ecosystem resilience, which should be considered during analysis of photographs (Box 4.5). All of them are related to the potential for water and matter storage by landscape structures.

**Regulation of rivers**

Changes in riverbed shape, appearance of embankments and, what is even more spectacular, decline or disappearance of land-water plant buffering zones, indicate loss of connectedness between a river and its valley. It leads to high hydrological variability, decline of water levels and discharges, water shortages in agricultural areas, increases of chemicals leaking into surface and ground waters, and, finally, a decline of biodiversity.

### Erosion

Areas undergoing erosion are identified as lighter patches situated along a river corridor. The indicator of bottom erosion is a deepening of the river valley and a tendency of the river to occupy its whole width.

Erosion may be natural, resulting from the geological and morphological structure of the catchment (e.g., loess areas) or human-induced. In the latter case, it usually reflects degradation of the vegetation cover and inappropriate distribution of different use areas. The cause of erosion may be located far from the place where it is observed.

### Urbanization

The increase of the percentage of urban areas compared to natural and semi-natural areas is an indicator of possible water and environmental quality deterioration.

Analysis of the rate and direction of expansion of urban areas may provide additional information about potential threats to the environment and the necessary management counteractions.

### Fragmentation

It is well known that medium land patchiness is the optimal one for sustainable landscape management.

Landscapes characterized by large, homogenous areas are a source of non-source pollution, erosion and, hence, water siltation. From a biological point of view, they also encourage the spread of diseases and biodiversity loss.

High patchiness of the landscape, especially when resulting from increased density of anthropogenic ecotones, disturbs chemical and water circulations in a catchment. It also does not provide stable conditions and space required by organisms for completing their life cycles.

### APPLICATION OF GIS TECHNIQUES

Geographical Information System (GIS) is a program which has the capability of storing and analyzing digital maps and remote sensing images using different software components (Box 4.6).

GIS may operate easily at the single ecotone scale up to the largest catchment scale. It is used for:

- ▶ visualization and communication (distribution, properties, spatial relations between objects);
- ▶ to measure and inventory (e.g., how much of a resource is present); and
- ▶ analysis, prediction, modelling and decision making.

### How does a GIS system operate?

Every natural phenomenon has a spatial and temporal dimension, which means it occurs at a given location and at a particular time. Natural objects (entities) are represented in GIS by:

- location (typically expressed as: x-y, or eastings-northings, or latitude-longitude coordinates); and
- attributes (type of observation, counts, measured value, time, etc).

The location of an object is defined within a coordinate system, e.g., the Cartesian one (coordinates x, y - for a flat surface on map) and the latitude-longitude system (coordinates x,y - for the glo-

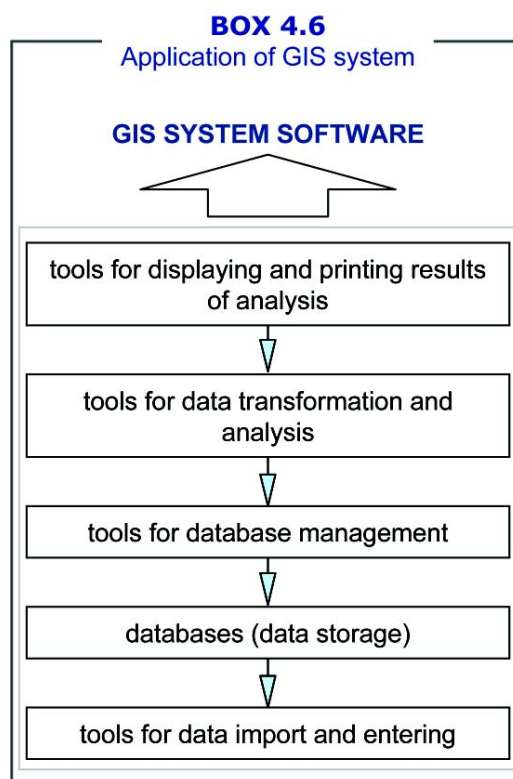

be and in GPS (satellite positioning systems). Data described in orthogonal cartographic coordinates make it possible to perform cartometric calculations of object length, area or volume. Attribute data can be a name, number, class value or qualitative description (verbal, pictorial or numerical).

**Geometric representation** of an object in a given coordinate system is a **point**, **line**, or **surface**.

- ▶ **Point** does not have a topological dimension, but in GIS programs it can be displayed as a symbol (for example, sampling point, source of pollution).
- ▶ **Line** is a sequence of points (segment), in which we may distinguish start and end points and nodes at an intersection of lines. Lines can be additionally described by code. For instance, elevation of a contour line. Lines may be used to represent linear features like streams, roads, and boundaries.
- ▶ **Surface** represents two-dimensional objects (lake, forest). Three-dimensional objects are represented as a surface, which have an elevation attribute (for instance, a digital terrain model).

#### Data visualization - analysis

In computer graphics there are two data models to represent the geometry of objects - vector and raster.

- ▶ Lines written in **vector format** may be used to represent networks (for example, river system), connected lines may enclose polygons or areas that are homogenous, e.g., land unit;
- ▶ A **raster** is a regular matrix of elementary cells or pixels. The location of each pixel is determined by the size of the grid and the pixel size or resolution. Each pixel stores the attribute data for that particular location.

Many GIS programs use both types of data formats. Both raster and vector layers should be registered in the same coordinate system. During registration a relationship between raster coordinates (i - row, j - column) and cartographic coordinates (x -

eastings, y - northings) are calculated. In hybrid graphics it is possible to perform conversions between data types called **vectorization or rasterization**.

The most common method of representing the complex nature of the real environment in computers is to use thematic layers.

Mathematical operations used for data processing can be performed on one or many thematic layers, including a third dimension written in a DTM. Spatial data analysis can include processing of object attributes and/or object geometry. Arithmetic operators (+, -, \*, /, ^, sqr) are used in cartometric calculations (distance, area, volume, direction) and in processing object attributes. Relational operators (=, <, >, =<, >=, <>) are used for processing attributes and are useful for selecting certain objects according to given criteria. Logical operators (OR, AND, NOT, NOR) are used for finding objects belonging to many thematic layers according to specified conditions. Statistical operators are concerned mainly with attribute values. They are used to calculate, histograms, variance, distribution and attribute value correlations. More advanced methods are cluster analysis, semivariogram, and econometric functions.

In addition to simple operators we may perform more complicated analyses like map overlays (crossing) and proximity analysis (buffer zones, network functions). GIS is also a good environment for data preparation for external mathematical models and visualization of the modelling results.

#### DATA INTERPRETATION FOR ESTIMATION OF LANDSCAPE SENSITIVITY

The capacity of the landscape to absorb anthropogenic pressures may differ due to geomorphology, precipitation pattern, structure of plant cover, land use and its intensity, number of inhabitants, etc.

Although there is no precise recipe for optimal land use, one can easily identify symptoms of declining landscape resistance:

- land fragmentation;
- rapid development of urban areas;
- increased erosion;
- water siltation;
- decrease of forested areas, shrubs, tree lines; and
- degradation of land/water plant buffering zones and wetlands.

Identification of these processes and their quantification, together with more detailed studies including analyses of water chemistry and biota, may allow for the elaboration of effective landscape management strategies based on phytotechnological and ecohydrological approaches.

#### **MAKE SURE TO CHECK THESE RESOURCES:**

Guidelines: chapters 3.A-3.G, 4.A-4.E, 4.G

<http://www.eman-rese.ca/eman/ecotools/protocols/terrestrial/vegetation/glossary.html>

[http://www.thewaterpage.com/aq\\_eco\\_july\\_01.htm](http://www.thewaterpage.com/aq_eco_july_01.htm)

<http://rst.gsfc.nasa.gov/Front/tofc.html>

<http://www.esri.com/software/arcview/index.html>

## 4.C. HOW TO ASSESS SOIL CONTAMINATION

Polluted soils are a widespread issue and are problematic in terms of remediation. This is particularly true in the case of persistent pollutants (e.g., heavy metals and radionuclides), which are not amenable to natural attenuation. Soil remediation is expensive and often results in an alternative set of environmental considerations. As with all remediation efforts, a comprehensive understanding of the soil and the contamination are critical.

This chapter outlines major considerations in the design and implementation of a characterization program for contaminated land.



Fig. 4.3  
Collecting of soil samples  
(photo: R. Kucharski)

### WHY SHOULD WE ANALYZE SOIL CONTAMINATION?

Soil pollution has to be analyzed in a broad context due to the potential for interactions among soil, ground water, surface water and air. Contaminated soil can affect all of these media, and through them, humans as well as other living organisms. The effects of soil pollution can be observed far away from the source, even hundreds of years after the polluting activities have ceased (Alloway, 1995).

### LAND SENSITIVITY

Approaches to the assessment of land contamination differ, depending on the present or anticipated future land use. Fundamental questions include how the site will be used, who will use it and, „how clean is clean“. The key issue is known as „land sensitivity“, which is used to determine the maximum tolerable contamination levels when the land is used for a particular purpose. While overly simplified, the following land segregation categories may be used to illustrate this concept: (Box 4.7)

### STANDARDS

Permissible legal values for acceptable soil contamination vary from country to country. In many cases, countries allow site-specific flexibility in the development of clean-up standards. In Poland, where standards are based on the Dutch and German approaches, three categories of land use are recognized with associated sets of standards: (Box 4.8)

#### BOX 4.7 Land sensitivity

<u>SENSITIVITY</u>	<u>PURPOSE OF LAND USE</u>
VERY SENSITIVE	kindergartens, playgrounds, backyard gardens, farming areas
SENSITIVE	houses, apartments
MODERATELY SENSITIVE	offices, shops
LESS SENSITIVE	industrial facilities, roads, parking lots

#### BOX 4.8 Recommended land uses

<u>CATEGORY</u>	<u>PURPOSE OF LAND USE</u>
A	protected zones including national parks and water intake points
B	farming, forest and residential areas
C	industrial zones

**TABLE 4.6**  
Soil contamination standards for some pollutants

CONTAMINANT	CAT. A	CAT. B	CAT. C
		DEPTH [m]	
		0,0 – 0,3	0,0 – 2,0
<b>METALS</b>			
<b>Chromium</b>	50	150	500
<b>Zinc</b>	100	300	1000
<b>Cadmium</b>	1	4	15
<b>Lead</b>	50	100	600
<b>Mercury</b>	0,5	2	30
<b>HYDROCARBONS</b>			
<b>Gasoline (hydrocarbons C6-12)</b>	1	1	500
<b>Total aromatic hydrocarbons</b>	0,1	0,1	200
<b>Total polycyclic aromatic hydrocarbons</b>	1	1	250
<b>CHLORINATED HYDROCARBONS</b>			
<b>Aliphatic chlorinated hydrocarbons (total)</b>	0,01	0,01	60
<b>PCB</b>	0,02	0,02	2
<b>PESTICIDES</b>			
<b>DDT/DDE/DDD</b>	0,0025	0,025	0,25

(source: Polish Standards, 2002)

Examples of permissible concentrations in Poland are shown in Table 4.6. Benchmark values are developed from basic toxicological literature.

From these permissible concentration values are calculated using risk assessment methods. The same approach is used when planning soil clean-up activities. Remedial activities are preceded by a baseline risk assessment that is compared to standards applicable to the anticipated site use. Target clean-up values then are developed that would be safe for a theoretical population using the remediated area under the assumed conditions. This procedure is carried out routinely to evaluate the need for, and extent of, remediation (US EPA, 1989).

#### THREATS TO THE ENVIRONMENT

In many cases, the most vulnerable segment of the population is young children, whose direct and indirect exposure to contaminated soil is magnified by their physically active lifestyle and various exposure-increasing habits (e.g., licking dirty hands and toys (Roper, 1991). Exposure scenarios that consider childhood exposure are often the major factors in determining site remediation needs.

Agricultural land pollution plays a crucial role in the exposure of local populations to heavy metals. The consumption of contaminated agricultural products can be a significant source of contaminant exposure. Humans take up most metals through the digestive tract after ingesting contaminated foodstuffs, especially vegetables. The major source of heavy metal contamination to plants comes from soil pollution (Kucharski et al., 1994).

Another important exposure scenario involves site excavation, either for routine activities or for remedial purposes. Such a scenario envisions workers in direct contact with subsurface soils.

### BIOAVAILABILITY OF POLLUTANTS CONTAINED IN SOILS

Contaminants can exist in soils in a variety of chemical forms. These forms have varying uptake rates by living organisms (bioavailability). Bioavailability describes the ability of a specific chemical form to cross biological membranes (i.e., actually enter an organism). For example, very little of the metallic form of mercury is taken up following ingestion, while organic forms of mercury readily cross gastrointestinal membranes. Bioavailability of soil contaminants influences the risk posed to living beings and, thus, the need for, and extent of, remediation required to insure the safety of exposed populations. In soils, bioavailability is influenced by physical, chemical and biological factors (including root, bacterial and fungal activities), as well as mechanisms of absorption into plants or animals (Brümmer et. al., 1986). Sequential chemical soil analysis is used to describe the speciation or bioavailability of metals. However, most legal regulations address only total concentrations of contaminants and do not take into consideration chemical speciation. However, this information can be used to evaluate the potential for adverse impacts from soil contamination on the food chain (Tessier et. al., 1979).

### HOW IS SOIL CONTAMINATION ASSESSED?

**What is the goal of site characterization?**

The goal of site characterization is the development of a conceptual site model that will be used to determine the need for, develop and guide, site remediation. The data generated from the chemical analysis of soil samples is further processed using statistical and visualization (e.g., GIS) processes.

Careful planning and implementation of site characterization is vital to the effective clean-up of a contaminated site. The initial involvement of all members of the remedial team (e.g., field personnel, soil scientists, chemists, statisticians and

toxicologists) when planning site characterization activities will streamline the process, reduce the need for additional characterization efforts and result in more effective remediation.

### How to collect representative samples

A sampling grid typically is used to determine the spatial variation of contaminants at a site. The sampling scheme needs to determine the extent (in both area and depth) and spatial variability of contaminants at the site, initially and during remedial activities. The number and location of samples will be site specific. Soil sampling patterns depend on a number of factors including site history, expected data needs and planned remedial strategy. There are a number of possible patterns for site characterization, e.g., circular grid, random, stratified, zigzag, transverse sampling and systematic (Box 4.9, ISO/CD/10381-5). For initial characterization of soil contamination (i.e., screening), samples are obtained using a sampling grid. An example of a field data sheet is shown in Appendix 1, which facilitates the systematic sampling and handling of samples (US EPA, 1989a)

### How deep should we sample?

The depth of samples is important to consider and should be based, in part, on the history of the site. It is important to remember the old adage that „one will not find that which is not sought“. Initial soil sampling often screens samples from several depth ranges (e.g., 0-15, 15-30, 30-45 cm). The top 30 centimeters of soil generally is considered when evaluating the threat posed to living organisms by contaminated soil (see chapter 9A). In some cases, e.g., construction purposes, where deeper layers of the ground will be exposed, a different and more extensive set of considerations will need to be applied.

Once the depth of contamination is known, further sampling can be concentrated in that depth range. Soil samples should be collected using equipment that is compatible with the physical and chemical needs of the sampling plan (e.g., disturbed vs. undisturbed, spot vs. composite samples). Plastic samplers or tubes generally are used for samples intended for metal analysis, while metal

samplers generally are used for samples intended for organic analysis. The most commonly used equipment for collection of spot samples is a split tube soil sampler (ISO/CD 10381). Contaminant presence is quantified using routine laboratory methods (ISO/DIS 11464).

**What parameters should be determined in a soil sample?**

Soil is a complex media and a number of variables exist which may influence the fate of anthropogenic substances introduced as contaminants.

**BOX 4.9.**

**Patterns for site characterization**

**CIRCULAR GRID**

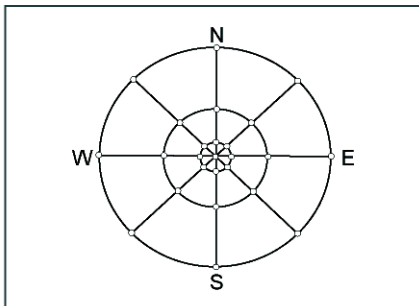

**RANDOM SAMPLING WITHOUT GRID**

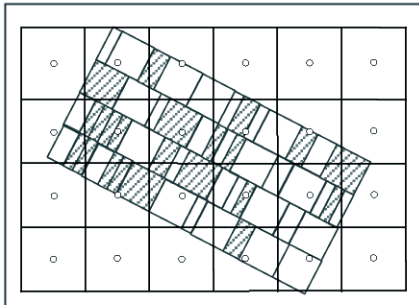

**ZIGZAG SAMPLING PATTERN**

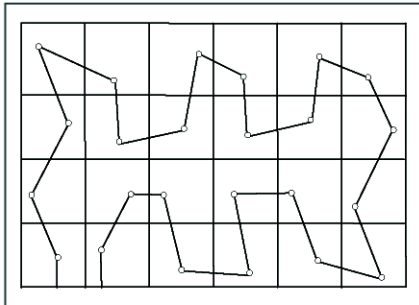

Fig. 4.4  
Mechanical auger  
Forestry Suppliers, Inc.  
Catalog 51, 2000-2001

Some basic factors can be isolated which are crucial to soil susceptibility. Basic soil parameters can be grouped into four groups (Korc et al., 2002):

- ▶ **mass transport characteristic** (soil texture, unsaturated hydraulic conductivity, dispersivity, moisture content/tension, bulk density, permeability, infiltration rate, soil layering);
- ▶ **soil reaction characteristics** that describe soil-contaminant reactions (soil-water partition coefficient, cation exchange capacity, acidity, redox, soil biota, soil nutrients, contaminant abiotic/biotic degradation rates, soil mineralogy);
- ▶ **contaminant properties** - solubility in water, dielectric constant, diffusion coefficient, or organic carbon partition coefficient, soil/water partition coefficient, Henry's constant, molecular weight, vapour pressure, density, chemistry of water extracts; and
- ▶ **soil engineering characteristics** and properties (erodibility, depth to ground water, thickness of unsaturated and saturated zones, depth and volume of contaminated soil, bearing capacity).



To obtain basic information on soil properties, the following analyses are routinely made:

- soil type, texture;
- conductivity;
- pH;
- content of organic matter;
- concentration of pollutants in question;
- fertility (vegetative capability);
- depth to ground water;
- surface runoff; and
- permeability.



Photo 4.5  
Various types of soil  
sampling equipment  
Forestry Suppliers, Inc.  
Catalog 51, 2000-2001

**MAKE SURE TO CHECK THESE RESOURCES:**

Guidelines: chapter 5.B

## 5.A. CAN GROUND WATER INFLUENCE SURFACE WATER QUALITY?

Groundwater, especially in catchments with intensive agriculture and grazing, may transport a considerable amount of dissolved pollution to fresh waters. During the growing period, pollution can be effectively diminished by application of phytotechnological methods. However, their application requires preliminary studies. The objective of this chapter is to introduce methods for analyzing groundwater movement and chemical composition in order to define the risk related to the transportation of contaminants from a catchment to lakes, rivers and reservoirs.



Fig. 5.1  
Sampling ground water at the Pilica River  
- an ecohydrology and phytotechnology  
Demonstration Site in Poland  
(photo: I. Wagner-Lotkowska)

### WHAT IS GROUND WATER?

The term ground water describes water present in the saturation zone that is separated from the earth's surface by a permeable zone of aeration. Ground water is delimited from below by an impermeable basement (impervious layer), from above by a free water table and aeration zone (Box 5.1).

#### BOX 5.1

##### The aeration and saturation zones

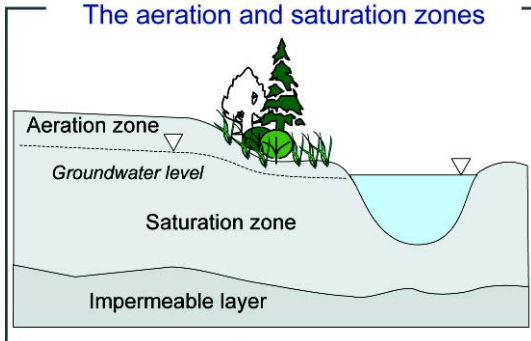

A groundwater table usually has a slope called the **hydraulic gradient**.

Ground water is susceptible to changes of temperature (up to 20 m below the ground surface), water table level fluctuations and chemical composition. Precipitation influences the groundwater level, but the deeper below ground level the water table is, the more delayed are its changes. Ground waters are interconnected with surface waters in two ways:

- ▶ streams supplied by ground water, or effluent streams; and

- ▶ groundwater supplied by streams, or influent streams (Box 5.2).

Identification of the stream character can be done using hydroisochip diagrams:

- ▶ ground water drained by a river when the groundwater table falls towards a stream and
- ▶ infiltrating stream, when the underground water table reaches the highest level near a stream bank and falls towards a valley.

The characteristics of interaction between a stream and underground water can change both spatially and temporarily: the stream can be an effluent and change into an influent or vice versa.

#### BOX 5.2

##### Interconnections between ground water and surface water

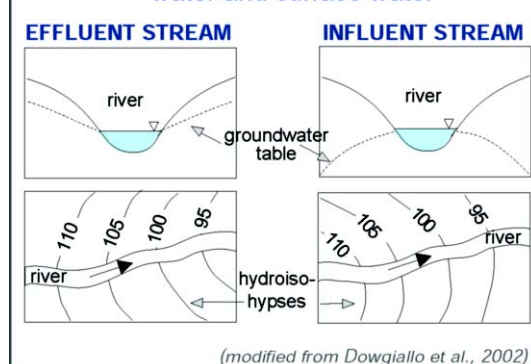

### GROUNDWATER SUPPLY SOURCES

Supply of underground water is provided by so called **effective infiltration**. Precipitation infiltrates to deeper strata (Box 5.3), but part of this water is kept in the aeration zone and used by plants.

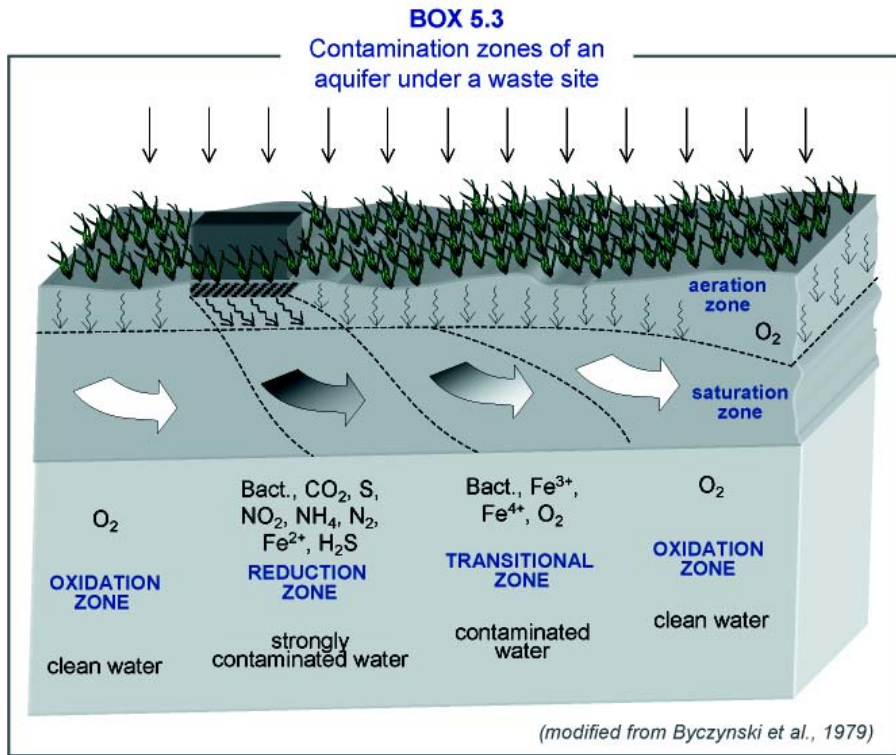

The other part of the water penetrates deeper into the **saturation zone**. Water supplying ground water causes its level to rise and is called effective infiltration. The volume of infiltration depends on the quantity and intensity of precipitation, soil type and its initial humidity, plant cover etc. Shortages of precipitation and ground with low humidity may result in the storage of the all rainfall in the unsaturated zone.

#### GROUNDWATER CHEMISTRY

Chemical composition of ground water is influenced by:

- ▶ precipitation;
- ▶ chemical composition of the soil;
- ▶ period of water cycling;
- ▶ relief and vegetation;
- ▶ land use and anthropogenic activity

#### GROUNDWATER CONTAMINATION

Underground water is subjected to pollution connected with human activity, originating from agri-

culture, farming and settlements.

Pollution can manifest itself as follows:

- ▶ increased concentrations of ions commonly appearing in groundwater, e.g.,  $\text{NO}_3^-$ ,  $\text{NO}_2^-$ ,  $\text{PO}_4^{3-}$ ,  $\text{K}^+$ ,  $\text{Na}^+$ ,  $\text{Ca}^{2+}$ ,  $\text{Mg}^{2+}$ ,  $\text{Fe}^{2+}$ ,  $\text{SO}_4^{2-}$ ,  $\text{Cl}^-$ ;
- ▶ appearance of man-made organic substances (pesticides and products of their degradation);
- ▶ increased mineral matter, conductivity, solid residue, and water hardness; and
- ▶ increased oxidation rate, BOD and bacterial contamination (see Guideline chapter 5).

All pollutants while being dispersed in the ground undergo alterations. The following factors influence the potential threat of pollutants:

- ▶ presence and thickness of impermeable layers above aquifers;
- ▶ thickness and type of soil cover;
- ▶ depth of aquifers; and
- ▶ self-purification processes of infiltrating water.

**BOX 5.4**  
Map of isolines showing areas  
of equal groundwater head

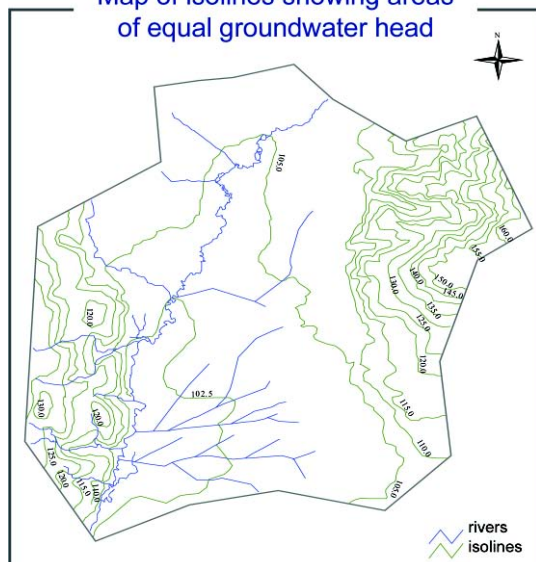

### COLLECTION AND ANALYSIS OF LANDSCAPE INFORMATION

The first step, which should be done to assess pollutant infiltration processes from the surface into ground water supplying a stream, is collection of basic information such as:

- ▶ **maps:** topographic, soil, hydrographic, and geological from geological and hydrological archives for:
  - average annual and monthly precipitation, preferably for the last 25 years;
  - average annual snow precipitation and duration period as well dates of the appearance and disappearance of the snowcover;
  - average multi-annual duration and start dates of the growing season; and
  - average annual and monthly run-off (in mm).
- ▶ **statistical data** (use of fertilizers, pesticides, doses and usage periods, land use structure):
  - history of land use, preferably for last 100 years;
  - recent land-use patterns (forests, arable lands, grasslands, urban areas, waters); and
  - characteristics of anthropogenic activity in the catchment and its nearest vicinity: industrial plants, rail routes and roads, in

tensive agriculture and farming, forestry, touristic and recreational pressures, changes in water budget, etc.

#### Field studies and sample collection

The first step in field studies should be identification of „hot spots“ in the catchment, which can potentially influence groundwater quality:

- ▶ localized point sources of pollution (village, dumps, pesticides store houses, fertilizers, chemicals, cesspools, filling stations, etc.); and
- ▶ identification of non-point source pollution (fertilizers used in agriculture).

Data on water quality and transfer of contaminants with groundwater movement to surface water can be obtained from piezometers. There are installed in transects located along the gradient of groundwater flow from a pollution source toward a stream (Box 5.4).

All piezometers in a transect should be denivelated in a floodplain according to the national geonet using a tachymeter in order to obtain precise data from each piezometer (Box 5.5).

**BOX 5.5**  
Nivelator



**BOX 5.6**  
Hydrogeological cross-section

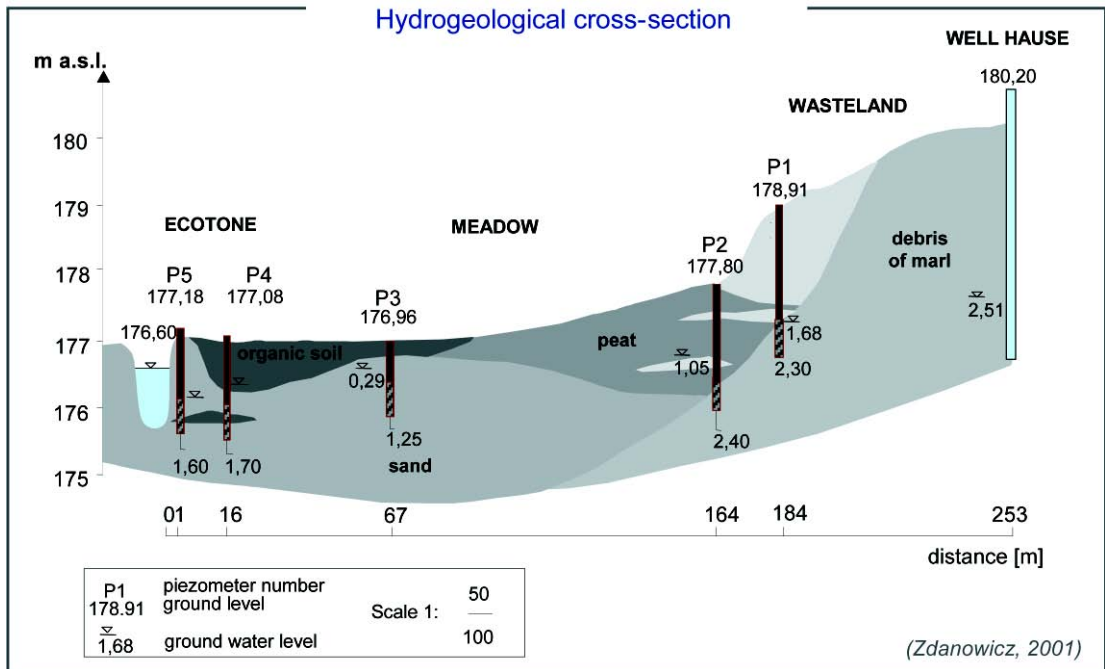

Simultaneously with drilling holes for inserting piezometers, samples should be taken for determination of soil granular composition. This information is used to determine the filtration coefficient (k) using, e.g., the USB method. On the basis of these results, the hydrogeological section pattern for a given transect can be created. (Box 5.6).

**Groundwater Measurements**

Groundwater level can be measured with various methods. The most frequently used and simplest tool to determine groundwater levels is a measuring tape that is inserted into a piezometer.

**Sampling**

To obtain water samples from a piezometer, pumps and samplers are used. The following steps should be followed:

- ▶ Determine groundwater level;
- ▶ pump out a minimum of three volumes of the water column flowing into a piezometer;
- ▶ sample water for chemical analysis.

Field measurement procedures:

- ▶ record water temperature - preferably by digital or liquid thermometer exact to 0.1°C;
- ▶ record pH with a pH-metre; and
- ▶ record conductivity with a conductivity metre;
- ▶ water sampling for chemical analyses in the laboratory: store water samples in propylene containers.
  - anion samples - capacity of 250 cm<sup>3</sup>; the container should be filled to the top without leaving a headspace;
  - cation samples - capacity of 60-125 cm<sup>3</sup>, preserved with hydrochloric acid. Add 5 cm<sup>3</sup> HCl (1:1) for each 100 cm<sup>3</sup> of water sample. Samples should be filtered through a membrane or glass-fibre filter.

**Estimation of groundwater flow rate using the empirical method**

True flow velocity can be calculated from the expression:

$$U = \frac{V}{\mu} \text{ [ms}^{-1}\text{]}$$

where:

$\mu$  - effective porosity (read from a table)

v - apparent velocity calculated using the expression:

$$V=ki$$

where:

k - filtration coefficient [m d<sup>-1</sup>],

i - hydraulic gradient [m], calculated using the expression:

$$i = \frac{\Delta h}{l}$$

where:

Δh - difference between groundwater table levels of two piezometers [m],

l - distance between the piezometers.

(Box 5.7)

### Sampling frequency

Water samples should be taken twice a week or monthly.

### BOX 5.7

#### Example of groundwater flow rate calculation: index method

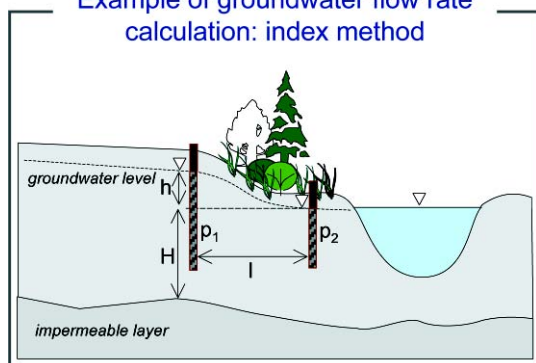

### BOX 5.8

#### Example application of a GIS programme (Arc Info, Arc View). Map of nitrogen content in ground water

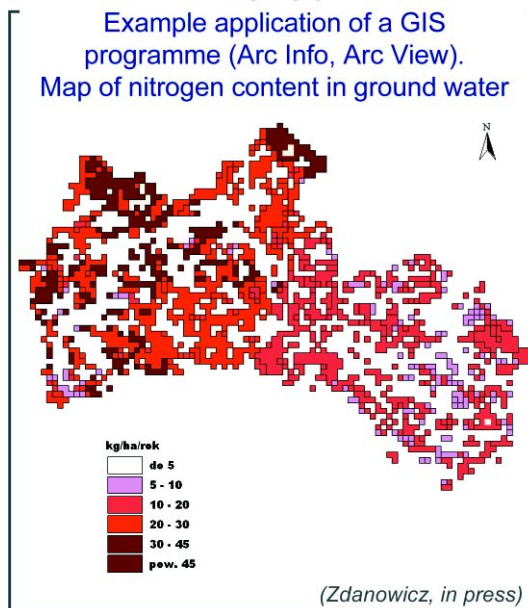

(Zdanowicz, in press)

### INTERPRETATION AND VERIFICATION OF RESULTS

Data analysis starts by gathering information from the different measurements, tabulating it and then preparing graphs and diagrams using appropriate software (e.g., Excel, Statistica, Grafer, Corel).

Results of landscape studies are presented in the form of maps using GIS: Arc Info, Arc View, Map Info or other types of software (Box 5.8).

Prediction scenarios of groundwater quality changes and analysis and timing of pollutant flows from ground water to surface water can be estimated on the basis of mathematical modelling using models of pollutant transport, e.g., FLOTRANS, MOTFLOW, MT3D, etc.

### MAKE SURE TO CHECK THESE RESOURCES:

Guidelines: chapters 1.E, 3.A-3.G, 9.A-9.C

[www.scisoftware.com](http://www.scisoftware.com)

[www.goldensoftware.com](http://www.goldensoftware.com)

## ■ 5.B. HOW TO ASSESS THE EFFICIENCY OF ECOTONES IN NUTRIENT REMOVAL

**Ecotone zone** is the transition between two different ecosystems. From the point of view of water protection and restoration of freshwater ecosystems, a special role is attributed to land /water ecotones (riparian zones). They regulate the exchange and spreading rates of chemical compounds between terrestrial and water systems therefore they are buffers or filters in landscapes. The objective of this chapter is to introduce some basic information related to estimation of the role of ecotones in regulation of nutrient retention in a land-water transitional zone.

### NUTRIENT MOVEMENT

Depending on the dominant type of land use, nutrients move from terrestrial ecosystems into ground and surface waters at different levels.

The most important nutrient sources are cereal monocultures, although arable lands in general should be considered as a cause of water eutrophication (Table 5.1).

**TABLE 5.1**  
Range of total and dissolved phosphorus loss from land used for different purposes

LAND USE	total phosphorus	dissolved phosphorus
arable land	0,04-6,3	0-0,13
forested land	0,02-1,0	0,02-0,08
pastures	1,1-5,6	0,4-2,4
cereal cultures	0,1-67,0	-
urban areas	0,92-56,0	0,9-2,0

(Hilbricht-Ilkowska, 1995)

The role of intense land use and increasing fertilizer application in worsening water quality is exaggerated by the loss of buffering zones, especially riparian ecotones that have been transformed into pastures or arable lands.

### WHAT IS THE ROLE OF ECOTONES?

There are many different types of riparian ecotones: swamp forests, bank vegetation, meadows, littoral zones, marshes, floating mats, oxbow lakes, etc. Their common feature is occasional flooding. The water regime modifies the rates of



Fig. 5.2  
Water hyacinth is a weed that rapidly recycles nutrients in aquatic ecosystems (photo: V. Santiago-Fandino)

aerobic and anaerobic biochemical processes and hence seasonal releases and removal of phosphorus and nitrogen.

Although the role of riparian vegetation is pronounced in regulating biochemical cycling, it may be much broader, including:

- ▶ preventing banks from being eroded;
- ▶ regulating water temperature and light penetration to a river bed;
- ▶ therefore also regulating primary production in streams and reservoirs; and
- ▶ creation of habitats for fauna.

### CONNECTIVITY BETWEEN STREAMS AND ADJACENT SYSTEMS

The influence of ecotone vegetation on water quality is possible only when the connection between terrestrial and water ecosystems is maintained. The basis for this connection is water circulation, therefore, the role of ecotones is significant only along unregulated river courses and natural shores of reservoirs.

Under natural conditions, the influence of plant buffering zones on biochemical processes in fresh waters may vary from place to place according to the local geomorphology, soil type, moisture, interactions between plants and other organisms, etc (Box 5.9).

In the case of rivers it is also necessary to consider role changes of ecotones along a river course caused by changes in the water volume/length relationship (Box 5.10).

### BOX 5.9

#### Three main groups of factors which influence the efficiency of ecotone zones in nutrient removal

1. nutrient supply ratio – depending on the type and intensity of land use;
2. ground structure and soil characteristics as they decide about sorption capacity of a zone; and
3. catchment incline (for details see the MANAGEMENT part of the Manual).

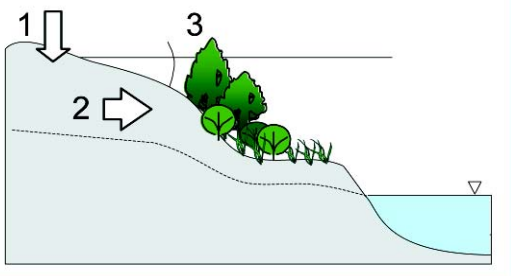

#### NATURAL PROCESSES INVOLVED IN NUTRIENT REMOVAL

##### Biochemical processes

There are two groups of processes responsible for nutrient retention and transformation:

- ▶ those occurring in **aerobic layers** - precipitation and sorption of P on clays (due to presence of Al, Ca, Fe ions), nitrification of N; and
- ▶ in **anaerobic layers** - release of P, fixation and denitrification of N (at oxygen concentrations below  $4 \text{ mg L}^{-1}$ ).

### BOX 5.10

#### Changes of ecotone influence on biochemical processes along a river course

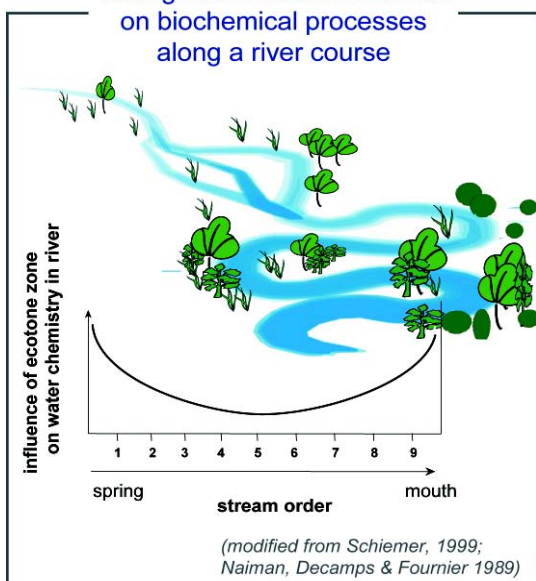

As the presence of aerobic and anaerobic conditions is dependent on water level, it is of great importance to preserve the hydrological dynamics (rate and timing of events) in a landscape typical for dominating ecotone communities.

##### Role of vegetation

The role of riparian vegetation in maintaining the resilience of freshwater ecosystems is based on:

- ▶ increase of infiltration of surface flow;
- ▶ decrease of surface flow velocity due to greater coarseness of groundcover vegetation;
- ▶ enhanced sedimentation; and
- ▶ nutrient retention in soil and plant tissues.

Naturally occurring riparian communities in temperate climates: alder forests (*Alnetea glutinosae*), mixed ash and alder forests (*Quercio - Fagetea*), wet meadows (*Molinio - Arrhenatheretea*) and rushes (*Phragmitetea*).

They may appear separately or form successive zones significantly reducing nutrient concentrations in ground waters and diminishing surface flow from agricultural areas (Klosowski, 1993).

Zonation and species composition, together with hydrological and soil conditions, determine the physical structure of riparian habitats. This is worth underlining because plants themselves accumulate only 10-50% of nutrients passing through the buffering zone (mostly during the growing season). The remaining pollutants are retained by other ecotone components (Box 5.11).

##### Ecotone efficiency

According to Petersen et al. (1992), the efficiency of wide ecotone zones (19-50 m) may reach even 78-98% removal for N in surface waters and 68-100% in ground waters. Other authors estimate reduction efficiency at a level of 50-90% for nitrogen and 25-98% for phosphorus (in ground water) depending on the initial concentrations, width of buffering zone, soil type and according to Intermediate Complexity Concept (see chapter 11.C) the complexity of the ecotone structure (Peterjohn & Corella, 1984; Verhoeven et al., 1990).

It has also been found that the most intense reduction occurs within the first 10 m of an ecotone zone (Box 5.12).



**BOX 5.11**

Mechanisms and elements involved in nutrient retention in buffering zones covered with reeds (*Phragmites australis*)

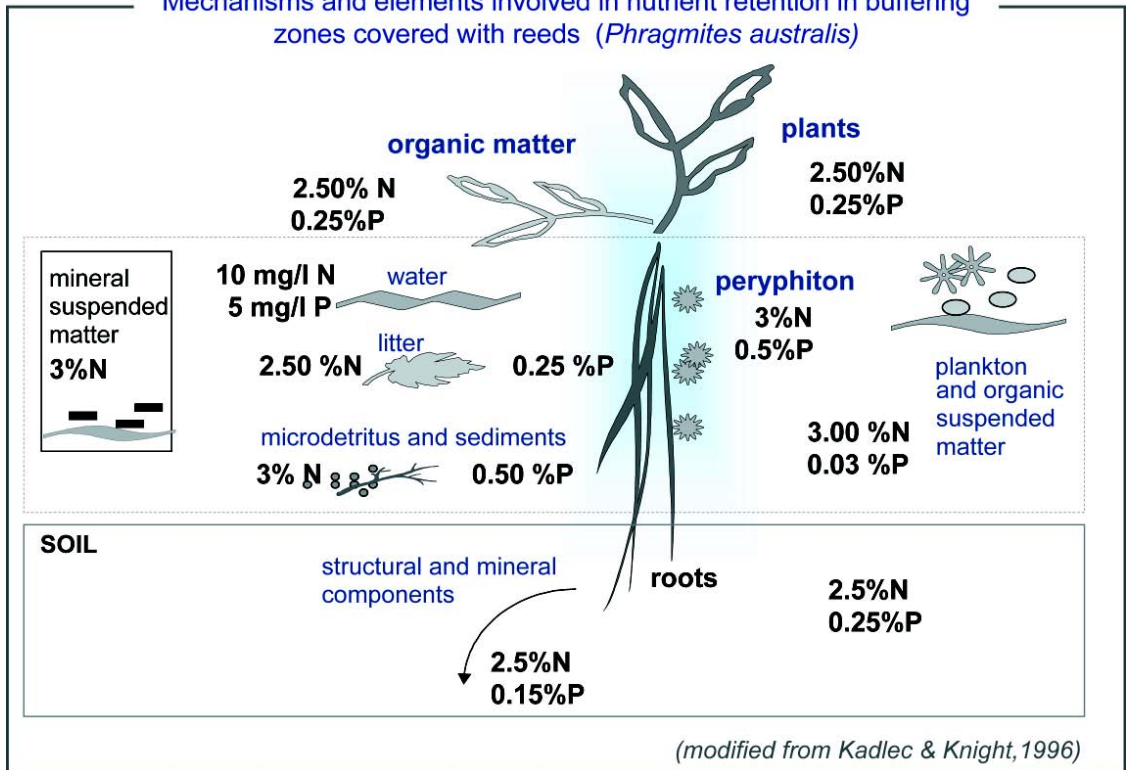

**HOW TO ASSESS THE EFFICIENCY OF ECOTONES IN NUTRIENT REMOVAL**

Assessment of nutrient removal by ecotone zones requires:

- ▶ detailed geomorphology and aquifer analysis prior to the setting of sampling points;
- ▶ assessment of plant composition and zonation and preparation of maps;
- ▶ determination of the dominant type of land use in the neighbouring area; and

- ▶ installation of piezometer nets in transects across an ecotone zone - the distribution should reflect the plant zone distribution, including the area being considered as a pollution source and the recipient fresh water (Box 5.13);

Piezometer installation should be carried out in the season when the water level is the lowest (June-July in temperate climates). The phosphorus and nitrogen loads transported into a reservoir via ground water are calculated on the basis of underground inflow ( $L s^{-1} km^2$ ) and concentration of nutrients ( $mg L^{-1}$ ).

The physical-chemical analysis of water samples should include: pH, temperature, conductivity, oxygen concentration, dissolved forms of phosphorus and nitrogen -  $PO_4-P$ ,  $NO_2-N$ ,  $NO_3-N$ , and  $NH_4-N$ , and total phosphorus and nitrogen concentrations.

- ▶ piezometers should be installed in drilled holes reaching the first attainable water layer.
- ▶ samples of ground water for physical-chemical analysis are collected after measurement

**BOX 5.12**

Pattern of nutrient reduction in water passing an ecotone zone

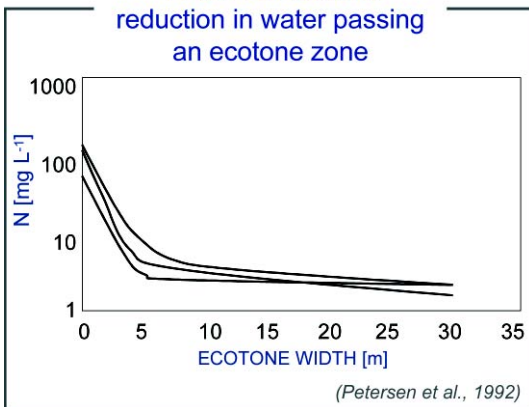

**TABLE 5.2**  
Data interpretation

<b>temperature</b>	temperature affects the solubility of many chemical compounds and can therefore influence the effect of pollutants on aquatic life. Increased temperatures elevate metabolic oxygen demand
<b>pH</b>	high pH values tend to facilitate solubilization of ammonia, heavy metals and salts. Lethal effects of pH on aquatic life occur below pH 4.5 and above pH 9.5
<b>dissolved oxygen</b>	dissolved oxygen affects the solubility and availability of nutrients, and therefore the productivity of aquatic ecosystems. Low levels of dissolved oxygen are the result of nutrient releases
<b>conductivity</b>	conductivity is useful for estimating the total ion concentration in water and may be used as an alternative measure of dissolved solids. It is often possible to establish a correlation between conductivity and dissolved solids for a specific body of water [dissolved solids = conductivity x 0.55 to 0.9 (usually 0.7)]
<b>PO<sub>4</sub>-P</b>	this form of phosphorus is the most readily available for uptake during photosynthesis.
<b>NO<sub>2</sub>-N</b>	since nitrite is also a source of nutrients for plants its presence encourages plant proliferation. Nitrite is toxic to aquatic life at relatively low concentrations
<b>NO<sub>3</sub>-N</b>	nitrate is the primary form of nitrogen used by plants as a nutrient to stimulate growth. Excessive amounts of nitrogen may result in phytoplankton or macrophyte proliferations
<b>NH<sub>4</sub>-N</b>	excess ammonia contributes to eutrophication of water bodies. This results in prolific algal growths that have deleterious impacts on other aquatic life, drinking water supplies, and recreation. Ammonia at high concentrations is toxic to aquatic life
<b>total phosphorus</b>	phosphorus is the most limiting nutrient, its input to freshwater systems can cause extreme proliferations of algal growth
<b>total nitrogen</b>	organic nitrogen is not immediately available for biological activity

of the water level inside the piezometers (e.g., by using a depth indicator bound to a tape measure) and movement of the water (see chapter 5.A).

- ▶ during the drilling and installation of piezometers, soil samples should be taken in order to assess the characteristics of a soil profile and to estimate the filtration coefficient of subsequent layers.

#### DYNAMICS OF NUTRIENT UPTAKE AND REMOVAL - CONCLUDING REMARKS

The dynamics of nutrient uptake by natural ecotone zones is determined by:

- ▶ **Land geomorphology** - in upland and mountain areas riparian ecotones are poorly developed and the incline of the catchment promotes rapid surface flow. Therefore, emphasis should be put on proper land management and development of biogeochemical barriers over a whole catchment area.

#### BOX 5.13

##### Installation of piezometers

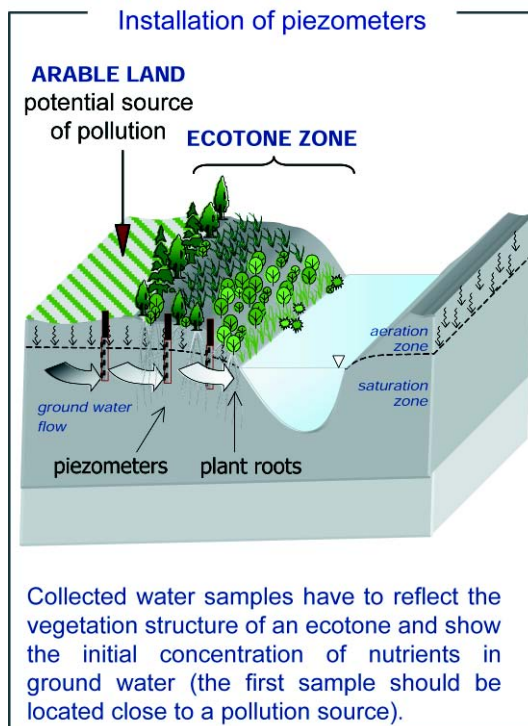

- ▶ **Nutrient load** - it was found that P removal rate exceeds 50% only when loading rates were lower than 50kg ha<sup>-1</sup> year<sup>-1</sup>.
  - ▶ **Season** - it was estimated that in temperate zones vegetation works as a trap for nutrients for 9 months on average; effectiveness for N-trapping is higher and prolonged due to high microbial involvement in transformation processes.
  - ▶ **Plant composition** - herbaceous vegetation is more active in nutrient uptake and accumulation due to dynamic growth, while trees and shrubs block nutrients for longer periods and require less conservation.
- Finally, it has to be stressed that natural ecotones and riparian wetlands in many cases play not only the role of nutrient barriers, but also transformers - they import inorganic forms of nutrients and export organic ones and also buffer and smooth nutrient pulses.

**MAKE SURE TO CHECK THESE RESOURCES:**

Guidelines: chapters 5.D-5.E

[http://www.thewaterpage.com/aq\\_eco\\_groundw.htm](http://www.thewaterpage.com/aq_eco_groundw.htm)

<http://srmwww.gov.bc.ca/risc/pubs/aquatic/design/index.htm>

[http://www.thewaterpage.com/aq\\_eco\\_july\\_01.htm](http://www.thewaterpage.com/aq_eco_july_01.htm)

## ■ 5.C. HOW TO ESTIMATE EFFECTS OF RIPARIAN AREAS AND FLOODPLAINS ON WATER QUALITY AND QUANTITY?

Riparian areas are natural elements of each stream and river. They can be defined as an ecotone, or an extended system of ecotones and riparian areas located along a water body. However, usually their structure and role is more complex. Restoration and management of flooded areas is of crucial importance for proper functioning of river systems as well as the water bodies located downstream. The objective of this chapter is to present methods for identification of flooded areas and to assess their potential role in controlling the quantity and improving quality of water and the environment.



Fig. 5.3  
Floodplain of the Pilica River in central Poland,  
a lowland river  
(photo: I. Wagner-Lotkowska)

### WHAT ARE THE ELEMENTS OF A RIPARIAN AREA?

Riparian areas are complex systems that provide optimum habitat and food for stream communities. They are characterized by floral and faunal communities distinct from surrounding upland areas.

Generally, the following elements can be distinguished in riparian area:

- ▶ **swamp areas**, directly adjacent to the stream or river;
- ▶ **transitional swamp areas**;
- ▶ **ecological corridors**;
- ▶ areas covered with **organic soils**;
- ▶ areas of seasonally **high groundwater level** (0,6 m below the ground level);
- ▶ **hill slopes**, with slopes greater than 15 %, directly enclosing a stream or river;
- ▶ areas **flooded with a 100-year flood**, i.e., a flood with a 1% probability of recurring; and
- ▶ **buffering zones**.

Riparian may contain also such features as backswamps, delta plains, and oxbow lakes.

### WHAT IS A FLOODPLAINS?

A floodplain is a flat area located alongside a stream or river channel that is inundated during high river discharges. Floodplains are formed by the deposition of sediments during periodic floods. Floodplains are designated by flood frequency that is large enough to cover them. For example, a 10-year floodplain will be covered by a 10-year return-flood and the 100-year floodplain by a 100-

year return-flood. This means floods that will re-occur with probabilities equal to 10% and 1%, respectively.

### WHY SHOULD WE DESIGN AND PROTECT FLOODED AREAS?

Flooded areas play a variety of roles in regulating the quality and quantity of rivers, as well as that of reservoirs and lakes located downstream. To a great extent they may regulate the self-sustaining potential of a river ecosystem and increase its absorbing capacity against such threats as landscape degradation and consequential increases of diffuse pollution and flood risk. Properly managed floodplains are responsible for:

- ▶ **stabilization of river discharge**, mitigation of the effects of **floods and droughts**;
- ▶ providing a framework for biogeochemical processes taking part at land-water interface zones and enhancing matter retention and self-purification of a river; and
- ▶ providing a number of transitional land-water **habitats** and supporting development of **biodiversity** in an area.

*Floodplains are crucial for flood protection and discharge stabilization in lowland rivers; Floodplains enhance self-purification of a river and are sinks for dissolved pollutants and nutrients as well as suspended solids transported by rivers during floods.*

## HOW TO IDENTIFY A FLOODED ZONE

### Recognition

Depending on the scale of a river, the first step for identifying flooded areas and estimating their potential for water and pollutant retention, should be an analysis of maps and aerial photographs of a river corridor and adjacent areas located along its channel (see chapter 4.B). If possible, it should be supported with direct observations in the field.

### Data needed

The following information can be of importance for the preliminary work:

- ▶ **topographic and geological** characteristics of an area with special emphasis on the land located along a river;
- ▶ **hydrological characteristics** of a river and adjacent areas, including discharges of a river, distribution and density of other fresh water bodies and groundwater levels, if possible; and
- ▶ existing information about **land use and development of an area**.

The following materials, if available, can be useful for estimating the extent of a flooded area and their potential role for flood mitigation and water quality improvement:

- ▶ **maps of the area**
  - topographic maps - 1:10 000 scale (riverbed and adjacent floodplain areas);
  - topographic maps - 1:25 000 scale (floodplain and adjacent catchment);
  - topographic maps - 1:100 000 scale (catchment area for general overview of landscape use and structure); and
  - soil maps - 1: 5 000 scale.
- ▶ **hydrological and meteorological data**
  - yearly distribution of precipitation, snow cover, air temperature, potential evapotranspiration, in order to calculate **mesoscale** water circulation in the catchment; and
  - discharges with given probability of exceeding calculated values on the basis of a long term series of maximum discharges from gauged basins or determined by empirical methods in case of ungauged basins.

- ▶ **hydraulics data** - roughness coefficient determined on the basis of inventory, land use maps, aerial photographs, and literature
- ▶ **geodesy data**
  - river cross-sections; and
  - cross-sections of existing hydrotechnical infrastructure.
- ▶ **others**
  - photographs of a river, river corridor and floodplains;
  - aerial photographs of potentially flooded zones; and
  - video documentation of historical floods, if available.

## FIELD STUDIES AND MEASUREMENTS

To identify and assess the ecological potential of flooded zones for retention of water and matter, it is also necessary to carry out additional field measurements.

The basic information to be collected should cover the following:

- ▶ **characteristics of a riverbed** with detailed information about **hydrotechnical construction** and infrastructure; and
- ▶ detailed information about the **ecological value of an area**.

### Characteristics of a riverbed

Special attention should be given to the natural structure of a riverbed. The following parameters should be listed for river sections of interest for potential management of flooded areas:

- ▶ distribution, length and characteristics of **natural river sections**;
- ▶ distribution, length and characteristics of **regulated and canalized** river sections;
- ▶ width, depth and **cross sections** of a river in all characteristic areas, with special emphasis on the section where flooded zones are to be restored and adjacent upstream and downstream floodplain sections;
- ▶ **cover and stability of a riverbed grain-size distribution**; and
- ▶ existing and planned **hydrotechnical constructions** along a river.

Appropriate consideration should be given to bridges, roads, human settlements and other infrastructures. The following aspects should be taken into account:

- ▶ **potential risk of floods** for human populations and infrastructure;
- ▶ **potential impact** of infrastructure **on water flow** (especially bridges, dams); and
- ▶ **potential impact** of infrastructure on water quality (especially location of sewage treatment plants, tanks, industry etc. in areas potentially flooded).

### ECOLOGICAL VALUE OF AN AREA

In order to establish flooded areas to be restored, ecological studies should encompass the three following biotopes:

- ▶ water biotopes;
- ▶ land-water interface (flooded) biotopes; and
- ▶ land biotopes.

This assessment allows for the evaluation of the ecological value of particular biotopes. It also presents estimates of ability of flooded areas to maintain ecohydrological processes of importance for water and nutrient retention.

Assessments of biotopes can be conducted using either qualitative or experimental assessment methods. There are many methods for preparing ecological inventories. The choice depends on the target of investigation and type of development of an area and also on regional preferences and type of a river (mountain or lowland). In spite of many determination techniques for this, they are subject to bias by a researcher's point of view and that is why experience is required. LÖLFA/ LWA (1985) is an example of the criteria that can be taken into account for assessment of all biotopes. Ecological and landscape values of rivers are determined on the basis of an analysis that takes into account the following criteria:

- ▶ river morphology;
- ▶ hydrological characteristics;
- ▶ physical and chemical characteristics of water;
- ▶ river bed afforestations, water vegetation and water course scarp vegetation;

- ▶ biodiversity of biotopes, vegetation cover and distribution of native plant communities of a floodplain;
- ▶ river valley land use; and
- ▶ particular natural value of a valley.

Such analysis leads to determination of the natural water course category.

### ASSESSMENT OF VEGETATION COVER

It is necessary to estimate vegetation cover of floodplain areas in order to estimate floodplain potential for assimilation of nutrients by vegetation biomass. The vegetation cover can be indicated on maps by using a GPS system (see chapter 4.B). It is recommended to identify the native plant communities and their ability for nutrient retention and biomass production under various hydrological conditions (groundwater level, timing of flooding).

### ELABORATION OF A DIGITAL FLOODPLAIN MODEL

In order to identify an floodplain area for restoration, a digital terrain model (DTM) should be constructed. The model can be made on the basis of information from collected maps. In some cases, additional denivelation of a floodplain may be necessary.

Denivelation of a floodplain can be based on a network of altitude points created from irregular networks (TIN) by tachymeter measurements. On the basis of the collected data, the following information can be generated:

- ▶ geodetic description;
- ▶ visualization of the topography of an area; and
- ▶ a location-altitude map of a floodplain.

### ELABORATION OF AN INUNDATION MODEL

Inundation models of floodplains can be developed on the basis of location-altitude maps of an area by using hydraulic models. Boxes 5.14 and 5.15 give examples of floodplain areas for an upland and lowland river.

**BOX 5.14**

Stimulation of the flooded zones on an upland river. The hydrological and ecological capacity of the hydrotechnical construction allows for a 100-year flood

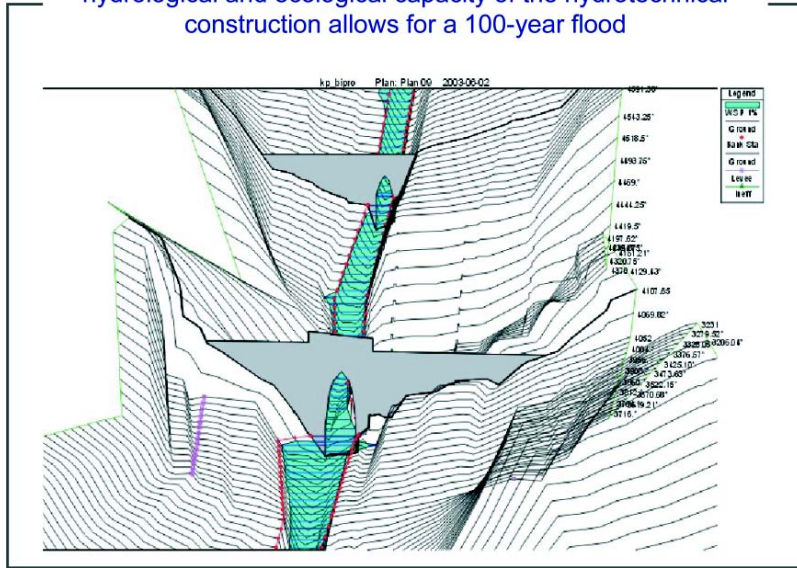

**BOX 5.15**

Stimulation of the flooded zones on a lowland river; Flood waters flow through grassland areas

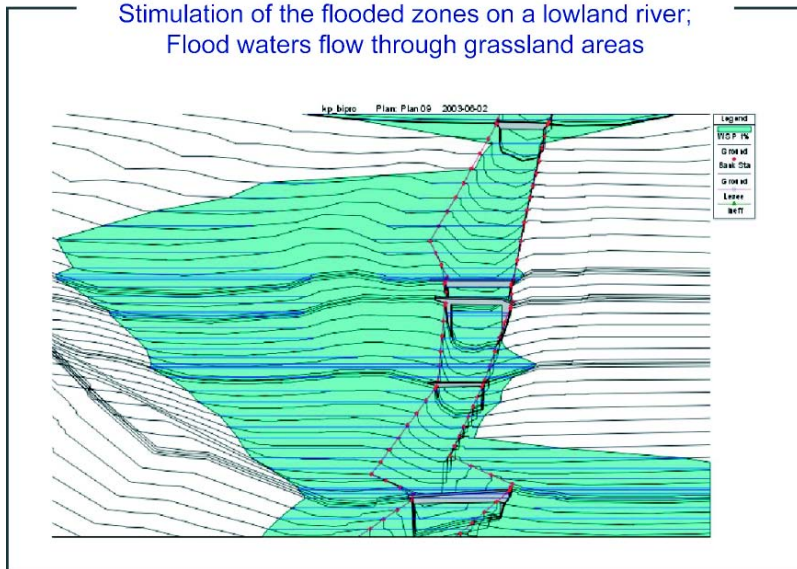

**MAKE SURE TO CHECK THESE RESOURCES:**

Guidelines: chapters 5.E-5.H, 7  
[www.biol.uni.lodz.pl/demosite/pilica](http://www.biol.uni.lodz.pl/demosite/pilica)

## 6.A. BIOASSAYS - A TOOL TO MEASURE ECOSYSTEM QUALITY

Biological monitoring programs are used worldwide to assess river condition. The use of biota to assess river condition has numerous advantages for complex river ecosystem quality assessments. As biotic communities are affected by a multitude of chemical and physical influences, the condition of the biota reflects the overall condition of a whole river ecosystem. This chapter reviews several international biological assessment methods and the potential to use physical assessment methods to complete bioassays.

### WHY FOCUS ON RIVER ECOSYSTEM ECOLOGICAL INTEGRITY (EI)?

Over the last decades the main focus of stream and river assessments has been on their chemical/physical water quality. The ability to measure this has been considerably improved in many industrial countries. However, riverine hydrology, morphology and connectivity still continue to deteriorate due to human activities in river basins. Today water directives (e.g., European Union Water Framework Directive, 2000/60/EC) challenges ecologists to provide practical methods for assessing the ecological integrity (EI) of running waters (e.g., FAME project).

Ecological Integrity (EI)  
of water ecosystem  
(ÖNORM 6232)

*Maintenance of all internal and external processes and attributes interacting with the environment insuch a way that the bioticcommunity corresponds to the natural state of type-specific aquatic habitats.*

### WHY BIOASSAYS?

Despite the availability of many geomorphological/physical assessment methods, there remains an urgent need to develop biologically sound assessments and to link both kinds of methods in a biological perspective.

River bioassays can be based on:

- ▶ phytoplankton;
- ▶ phytobenthos;
- ▶ macrophytes;
- ▶ benthic invertebrates; and
- ▶ fishes.



Fig. 6.1  
*Fish-based assessments have the highest power to detect change in riverine ecosystems (photo: Z. Kaczkowski)*

### BIOASSESSMENT (bioassay)

*Uses biota as the endpoint to represent environmental conditions and assess environmental quality.*

It has been stressed that as integrators at the highest trophic level in riverine ecosystems, fishes are indicators in river assessments that broaden management objectives towards an ecosystem perspective, e.g., by the Ecohydrology Concept (Zalewski, 2000).

### WHAT ORGANISMS CAN BE USED IN BIOASSAYS?

Selection of an indicator group of organisms should consider differences in potential error and accuracy of estimating river status. From this perspective, fish-based assessments are characterized by the highest power to detect change in riverine ecosystems and with the lowest error in this estimation (Box 6.1).

As shown in Box 6.1 indicator variability ( $\delta$ ) decreases along the x-axis in the manner: phytoplankton > zooplankton > macroinvertebrates > macrophytes > fish. Thus, e.g., phytoplankton will have higher  $\alpha$  and  $\beta$  error frequencies and, therefore, lower statistical power to detect change than other indicator groups such as fish.

### WHY USE VARIOUS INDICATOR GROUPS IN BIOASSESSMENT?

Selection of complementary early- and late-warning indicator groups reduces the probability of not detecting an impact if it occurs.

For instance, phytoplankton has high seasonal va-



**BOX 6.1**  
**Bioassessment - errors and accuracy**

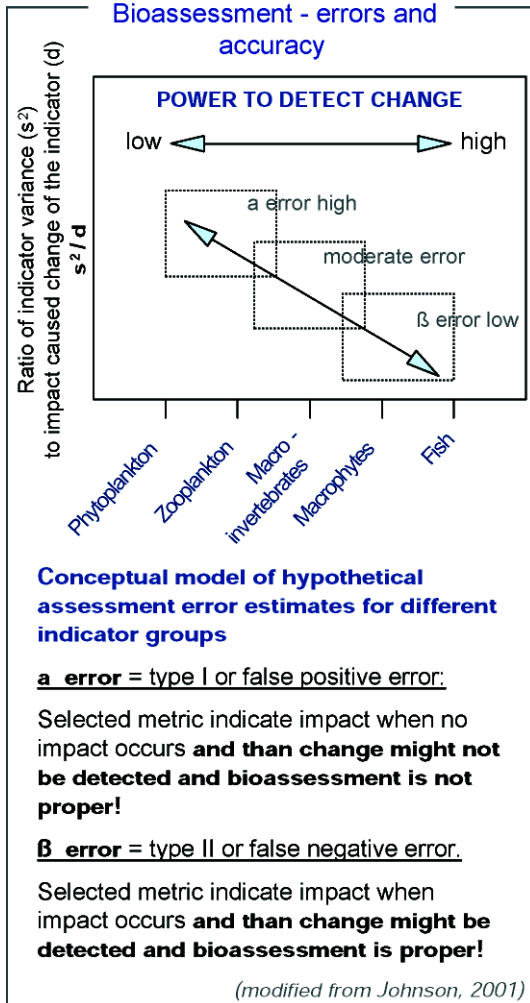

riability, limiting their use in environmental assessments (high  $\alpha$  error) (Box 6.1). Macrophytes have low seasonal variability, but due to slow changes in community structure, can not be used as an early warning indicator. But, when change is detected in macrophyte species composition, then an impact has probably occurred (low  $\beta$  error) - Box 6.1-(Johnson, 2001).

A combination of early-warning indicator groups (phytoplankton, periphyton) together with a late-warning, but statistically more accurate indicator group (macrophytes, fish), results in an optimal assessment of river conditions:

- ▶ **if the ecosystem-stressor is nutrient enrichment:**  
 consider phytoplankton or periphyton as first choice indicators, as they show a more ra-

pid response to eutrophication than macro invertebrate, macrophyte or fish communities.

- ▶ if the ecosystem-stressor is temperature: consider fish or macroinvertebrates as first choice indicators, as they show a more rapid response to changes in water temperature than phytoplankton or periphyton communities.

**WHAT METHODOLOGICAL APPROACHES CAN BE USED FOR RIVERINE QUALITY BIOASSESSMENT?**

The following methodological approaches to bioassessment are currently applied (Johnson, 2001; Faush et al, 1990):

- ▶ **single metric approach:** estimates richness, density of individuals, and similarity, diversity of communities (see chapter 6.B.);
- ▶ **multimetric approach:** aggregates several metrics as in, e.g., Index of Biotic Integrity (IBI index) for macroinvertebrates or for fish (see chapter 6.B.); and
- ▶ **multivariate approach:** measures the mathematical relationships among samples (e.g., similarity in structure of two communities) for 2 or more variables (e.g., qualitative presence-absence of species, or quantitative abundance or biomass of species) are selected. For example, Jaccard similarity coefficient, cluster analysis, discriminant analysis, ordination techniques (PCA, CA, CCA).

Choosing the method, or a combination of methods, should consider method advantages and, especially, disadvantages (Faush et al., 1990):

- ▶ multimetric
  - conceptually simple;
  - easy to compare to reference values;
  - More ecologically sound;
  - Dependent on sample size and ecoregion;
  - Easy to understand and interpret and apply by water managers.
- ▶ Multivariate
  - Conceptually complex ;
  - Higher precision than multimetric approach; and
  - Difficult to understand and interpret and to apply by water managers;

**TABLE 6.1**  
Bioassessment – examples of methods

ASSESSMENT METHOD	METHOD DESCRIPTION AND FOCUS AND CRITERIA	WHAT IS ASSESSED?
<b>BIOLOGICAL ASSESSMENT APPROACH</b>		
<b>RIVPACS</b> <b>(River Invertebrate Prediction and Classification System)</b> <i>Evaluated in United Kingdom by Wright et al., (1993)</i>	<ul style="list-style-type: none"> <li>▪ uses macroinvertebrate information as the basis upon which to assess the ecological condition of river sites;</li> <li>▪ the comparison between observed and expected fauna is used to assess the biological quality of sites;</li> </ul>	<b>Condition assessment</b>
<b>AUSRIVAS</b> <b>(The Australian River Assessment System)</b> <i>Evaluated in Australia by Simpson &amp; Norris, (2000)</i>	<ul style="list-style-type: none"> <li>▪ uses macroinvertebrate information as the basis upon which to assess the ecological condition of river sites;</li> <li>▪ macroinvertebrates are collected from reference sites, which are defined as sites representing least impaired conditions.</li> </ul>	<b>Condition assessment</b>
<b>IBI</b> <b>(Index of Biotic Integrity)</b> <i>Evaluated in USA by Karr, (1981)</i>	<ul style="list-style-type: none"> <li>▪ multimetric assessment index based on invertebrate or fish assemblages;</li> <li>▪ employs 12 metrics based on assemblage structure and function (fish or invertebrate assemblages) that give reliable signals of river condition to calculate an index score at a site, which is then compared to the score expected at an unimpaired, comparable site;</li> <li>▪ uses the "reference condition approach" which involves testing an ecosystem exposed to a potential stress against a reference condition that is unexposed to such a stress.</li> </ul>	<b>Condition assessment</b>
<b>HABSCORE</b> <b>(USEPA Rapid Bioassessment Protocols-RPB)</b> <i>Evaluated in USA by Barbour et al., (1999)</i>	<ul style="list-style-type: none"> <li>▪ Rapid Bioassessment Protocols (RBP) that use fish, macroinvertebrates or periphyton to assess stream condition;</li> <li>▪ this multimetric index represents the biological condition of a site;</li> <li>▪ physical and chemical data are also measured at each site, and are used to aid the interpretation and calibration of the index, and also to define the reference condition.</li> </ul>	<b>Condition assessment</b>
<b>MuLFA</b> <b>(Multi-Level concept for Fish-based, river-type-specific Assessment of ecological integrity)</b> <i>Evaluated in Austria by Schmutz et al., (2000)</i>	<ul style="list-style-type: none"> <li>▪ a multi-level concept for fish-based assessment (MuLFA) of the ecological integrity of running waters designed for large-scale monitoring programmes (e.g., European Union Water Framework Directive - WFD);</li> <li>▪ the principle of the MuLFA is based on assessing the deviation from undisturbed reference conditions;</li> <li>▪ MuLFA is sensitive to low- and high-dose human alterations, and due to its general character, can be adapted to all river types.</li> </ul>	<b>Condition and Ecological value assessment</b>
<b>SERCON</b> <b>(System for Evaluating Rivers for Conservation)</b> <i>Evaluated in United Kingdom by Boon et al., (1997)</i>	<ul style="list-style-type: none"> <li>▪ designed to assess the conservation value of rivers according to criteria of physical diversity, naturalness, representativeness, rarity, species richness and special features;</li> <li>▪ rating scores are derived for each variable and these scores are subsequently combined to produce indices for each of the conservation criteria;</li> <li>▪ Field data are collected using the RHS protocols</li> </ul>	<b>Ecological value assessment</b>
<b>PBH</b> <b>(Pressure-Habitat-Biota)</b> <i>Evaluated in New South Wales by Chessman &amp; Nancarrow, (1999)</i>	<ul style="list-style-type: none"> <li>▪ has been developed for use in small to medium sized rivers and streams;</li> <li>▪ measures variables representing the pressures on streams (e.g., physical restructuring, water pollution and introduced species), the habitat of streams (e.g., habitat area, habitat diversity and habitat stability) and the biota within streams (e.g., diatoms, riparian vegetation, macrophytes, macroinvertebrates and fish).</li> </ul>	<b>Condition and ecological value assessment</b>

(Dunn, 2000; Phillips et al., 2001; Parson et al., 2002)

**METHODS FOCUSED ON BIOLOGICAL ASSESSMENT**

The current methods used in bioassessment are described in Table 6.1.

**HOW TO LINK ASSESSMENT METHODS IN A BIOLOGICAL PERSPECTIVE?**

To improve the quality of river assessment physical and geomorphological, methods in addition to biological methods should be considered (Table 6.2). The common link between assessing river condition from biological and geomorphological/physi-

cal perspectives is the use of physical habitat as a template for biological processes and river ecosystem dynamics (Southwood, 1977; Townsend & Hildrew, 1994). Many currently apply bioassessment methods using physical assessment protocols to describe habitat conditions of indicator biota. Recently developed river assessment systems like, e.g., SERCON (Table 6.1), use both biological and physical assessment methods (RHS) to evaluate rivers for conservation. (See Guidelines: chapters 9.D-9.H)

**Table 6.2**  
Physical and geomorphological assessment – examples of methods

ASSESSMENT METHOD	METHOD DESCRIPTION	LINK WITH BIOTA
<b>PHYSICAL ASSESSMENT APPROACH</b>		
<p><b>Geomorphic River Styles</b> <i>Evaluated in Australia by Brierley et al., (1996)</i></p>	<ul style="list-style-type: none"> <li>ability to predict future river character and responses to disturbance, based on geomorphological process theory.</li> </ul>	Habitat based links between geomorphology and biota
<p><b>State of the River Survey</b> <i>Evaluated in Australia by Anderson, (1993a)</i></p>	<ul style="list-style-type: none"> <li>assessment at many levels - whole catchment, individual sections or individual tributaries, using data components individually or together.</li> </ul>	Empirical links between the parameters measured and stream biota (e.g., substratum, riparian vegetation)
<p><b>RHS (River Habitat Survey)</b> <i>Evaluated in United Kingdom by Raven et al., (1997)</i></p>	<ul style="list-style-type: none"> <li>assessment of habitat quality of rivers based on their physical structure;</li> <li>uses a database of habitat requirements, site/reach classifications and association with flora/fauna with different habitats;</li> <li>at each randomly selected site, a 500 m length of river is surveyed. At 50 m intervals along this length of river, 10 spot checks are performed. A range of features is recorded at each spot check. Data and photos of each sampling site are also stored electronically in a database;</li> <li>potential linkage with the RIVPACS and SERCON.</li> </ul>	<p>Uses the biotope and functional habitat approach to link physical habitat with the biota:</p> <p><u>The biotope approach</u> is top down in that the use of habitat units by biota is inferred from a knowledge of physical conditions.</p> <p><u>The functional habitat approach</u> is bottom up in that each habitat is defined from knowledge of the biota that are found in each habitat (Newson et al., 1998a).</p>
<p><b>IHAS (The Integrated Habitat Assessment System)</b> <i>Evaluated in South Africa by McMillan (1998)</i></p>	<ul style="list-style-type: none"> <li>measures components of a stream habitat relevant to macroinvertebrates, such as substratum, vegetation and physical stream condition;</li> <li>measured components are rated and a score representing a continuum of habitat quality is derived.</li> </ul>	Assumes that the habitat units are relevant to macroinvertebrate presence
<p><b>IFIM (The Instream Flow Incremental Methodology)</b> <i>Evaluated in USA by Trihey &amp; Stalnaker, (1985); Stalnaker, (1993); Stalnaker et al., (1995) under leadership of U.S.Fish &amp; Wildlife Service</i></p>	<ul style="list-style-type: none"> <li>a collection of computer models and analytical procedures designed to predict changes in fish habitat due to increments of flow change.</li> <li>IFIM software: Physical Habitat Simulation System (PHABSIM), Legal Institutional Analysis Model, Physical Habitat Assessment Model, SALMOD, Stream Network Temperature Model, System Impact Assessment Model.</li> </ul>	Assumes that flow-dependent physical habitat and water temperature determine the carrying capacity of streams for fish

(Dunn, 2000; Phillips et al., 2001; Parson et al., 2002).

## 6.B. FISH COMMUNITIES - INDICATORS OF RIVERINE DEGRADATION

Fish attributes clearly distinguish fishes from other aquatic organisms and underline their significance as essential indicators to assess the ecological integrity of running waters and to estimate their degradation. This chapter presents historical and recent approaches to correctly use fish as a tool in riverine bioassessment.



Fig. 6.2  
Fish communities reflect watershed conditions  
(photo: Z. Kaczkowski)

### WHY FISH-BASED RIVER ASSESSMENTS?

*„Fish communities reflect watershed conditions”, which means that a fish community is a sensitive condition indicator of both an aquatic ecosystem and its surrounding watershed. Because of this, fish communities can be used in biological monitoring to assess environmental degradation (Karr 1987).*

Several attributes of fishes underline their essential role as indicators of the ecological integrity (EI) of running waters (after Schmutz et al. 2000a):

- ▶ presence in almost all water bodies;
- ▶ well known taxonomy;
- ▶ well known life history;
- ▶ well known ecological requirements;
- ▶ available historical information;
- ▶ high habitat preferences make them indicative for habitat quality;
- ▶ migratory behavior makes them indicative of river continuum/river connectivity conditions;
- ▶ as top predators, subsume trophic conditions across a food chain;
- ▶ as members of a specific trophic guild, provide detailed information on respective trophic levels;
- ▶ longevity makes them indicative for long time periods;
- ▶ fishery and sport fishing has a long tradition in which fishes have been used as indicators for water quality; and
- ▶ economic and aesthetic value helpful in river-habitat protection and conservation planning.

### WHAT ARE FISH-BASED ASSESSMENT CONCEPTS?

The framework on how to use fish communities to describe levels of river degradation is well documented in the multi-level concept for fish-based, river-type-specific assessment of ecological integrity (MuLFA) (Schmutz et al., 2000a). The concept of this assessment method is based on the hierarchical organization of biota (Odum, 1971) and the linkages of the various organizational levels to temporal/spatial scales (Frissell et al., 1986; see: chapter 11.A). According to that theoretical principle, higher levels (fauna or river basin) are more persistent compared to lower levels (individual or microhabitat) and, thereby, less sensitive to degradation than smaller ones. Thus, only a set of assessment criteria selected from different hierarchical levels can guarantee that various human alterations can be detected.

Why taking into account the fish-based river assessment, It should be also considered that , riverine fish community is regulated by a continuum of abiotic-biotic factors, which pressure changes along river continuum and strongly depends on geographical area of the world (Box 6.9). The model described by Zalewski & Naiman (1985) considers a hydrology, slope and climate as major abiotic, and river productivity, predation and competition as major biotic factors. The general assumption of the model is that abiotic factors are of the main importance in all world river types, however while they become stable and predictable the biotic factors start to manifest themselves. Thus, with increase in river spatial hetero-

**BOX 6.2**  
 Model of abiotic-biotic factor continuum as regulators  
 of the structure and dynamics of riverine fish communities

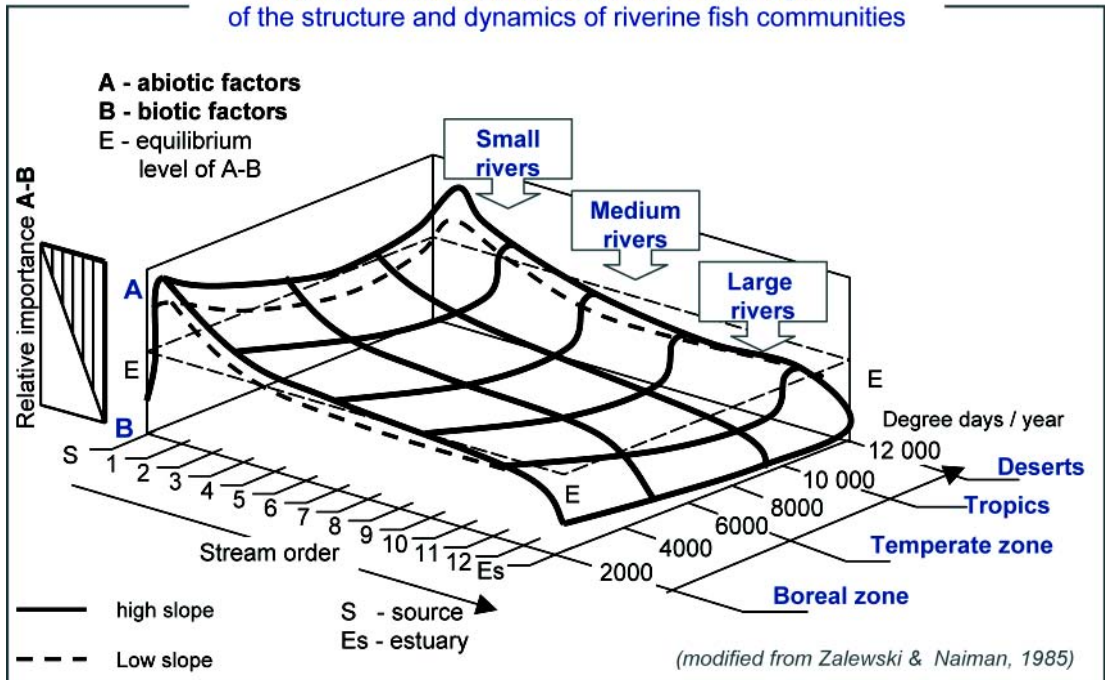

generity, habitat stability and temperature of water, what typically occurs with increasing river size (stream order) the gradually decrease of the influence of abiotic factors, toward biotic control, on fish community should be expected.

Therefore, to assess the EI of running waters using fish three approaches should be considered: diversity, community and population ones. The MuLFA concept distinguishes seven river assessment criteria (Schmutz et al., 2000a) - Box 6.3, 6.4:

The final assessment procedure is done by comparing an assessment reach with a reference condition reach using a 5-tiered normative scheme (Table 6.3).

MuLFA concept is designed for large-scale monitoring programmes such as required by the e.g. Water Framework Directive of European Community (WFD, (2000/60/EC). And the conceptual approach

presented in this chapter is realizing and developing in the research project FAME, supported by the European Commission (Development, Evaluation and Implementation of a Standardised Fish-based Assessment Method for the Ecological Status of European Rivers. A contribution to WFD.) The MuLFA index is sensitive to low- and high-dose human alterations and can be applied to all river types.

**BOX 6.3**  
 Three approaches to assess the EI of running waters

1. Type-specific species	<b>DIVERSITY APPROACH</b>
2. Self-sustaining species	
3. Fish region	
4. Number of guilds	<b>COMMUNITY APPROACH</b>
5. Guild composition	
6. Density and biomass	<b>POPULATION APPROACH</b>
7. Population age structure	

**BOX 6.4**

**MuLFA – Multi Level Fish-based Assessment Concept:**

A: Hierarchical organization of biota across temporal/spatial scales,  
 B: MuLFA assessment criteria

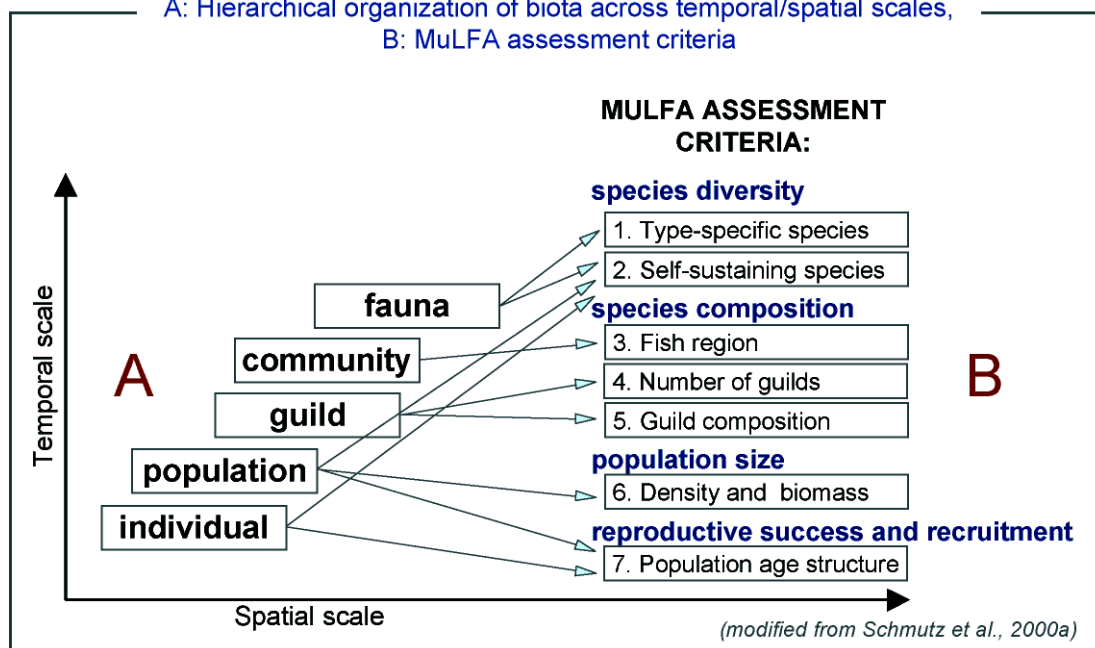

**TABLE 6.3**

MuLFA Index:

5-tiered normative scheme for river integrity assessment

CRITERIA	ECOLOGICAL INTEGRITY LEVELS				
	1	2	3	4	5
	High	Good	Fair	Poor	Bad
	totally or nearly totally undisturbed reference conditions	slight deviations from undisturbed conditions	substantial deviations from undisturbed conditions	strong deviation from undisturbed conditions	extreme deviations from undisturbed conditions
1. Type-specific species	none or nearly none missing	some species missing	several species missing	many species missing	most species missing
2. Self-sustaining species	none or some missing	several species missing	many species missing	most species missing	nearly all species missing
3. Fish region	no shift	no shift	shift	shift	shift
4. Number of guilds	no guild missing	no guild missing	single guilds missing	many guilds missing	most guilds missing
5. Guild composition	no alteration	slight alteration	substantial alteration	complete alteration	complete alteration
6. Biomass and density	no or nearly no changes	slight changes	substantial changes	heavy changes	extremely changed
7. Population age structure	no or nearly no changes	slight changes	substantial changes	heavy changes	extremely changed

*modified from Schmutz et al., 2000a*

**HOW DOES RIVER DEGRADATION AFFECT FISH SPECIES DIVERSITY?**

**Type - specific species (RTS-species)**

*RTS - (river type-specific species) criterion reflects the fish fauna naturally occurring in a specific type of a river, excluding species not native in a given area (e.g., country, ecoregion) and not autochthonous for that river.*

Generally, the number of native fish species increases with stream order for each type of river (Box 6.5).

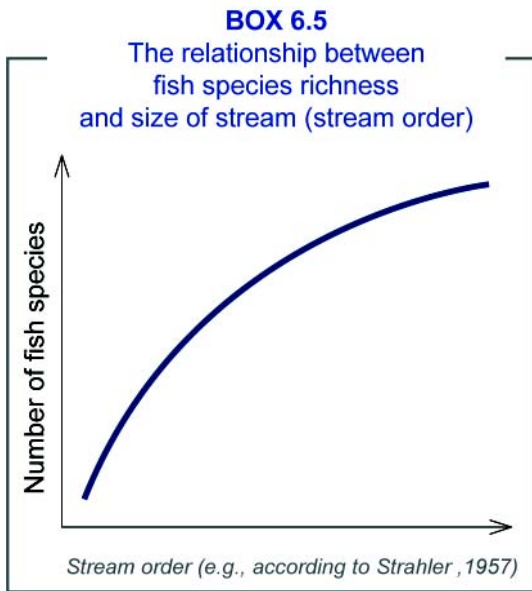

The main result of river degradation is the reduction of the number of fish species (fish species richness) and decrease in fish community diversity. Fish diversity can be easily estimated by the species diversity index (Shannon & Weaver, 1949). RTS-species criterion is important in situations

$$H' = \sum_{i=1}^s n_i/n \log_e n_i/n$$

where fish community diversity is still high, but native species are replaced by non-native species (e.g., introduced), thus indicating river degradation.

**Self-sustaining species (SSP-species).**

*SSP- species criterion reflects the type-specific fauna (RTS-species) composed of species meeting the following minimum criteria: the species are*

*self-reproducing, thus juvenile fishes occur, and maintain, at least a minimum population size.*

*Minimum population size - at least 50, or better 500, individuals able to reproduce in order to guarantee sufficient genetic variability (50/ 500-rule -Franklin 1980).*

**HOW DOES RIVER DEGRADATION AFFECT FISH SPECIES COMPOSITION?**

**Fish regions**

A riverine fish fauna can be described as a predictable sequence of distinct communities along a river course.

According to two concepts: the fish zonation concept (Thienemann, 1925; Huet, 1949) and the biocoenotic region concept (Illies & Botosaneanu, 1963), fish regions can be classified and named after the dominating key-species, which are associated with other specific fish species of that region:

1. Epirhithral - upper trout region.
2. Metarhithral - lower trout region.
3. Hyporhithral - grayling region.
4. Epipotamal - barbel region.
5. Metapotamal - bream region.
6. Hypopotamal - brackish water region.

Using this classification, the **Fish Region Index (FRI)** can be calculated (Schmutz et al., 2000b). The FRI index estimates the probability of occur-

$$FRI = (3xp3 + 4xp4 + 5xp5 + 6xp6 + 7xp7) / 100$$

rence of key-fish species in a given river region (Box 6.7, Box 6.8).

River degradation often results in a shift of fish regions to upper or lower regions. Thus, river channelization may cause a «rhithralization effect» in a fish community, or a shift to rhithral zone species. From another site, river impoundments may lead to a «potamalization effect», meaning a shift to potamal zone species (Jungwirth et al., 1995).





**BOX 6.7**  
Fish Region-Index (FRI) - an example

	p3 – epirhithral	p4 – metarhithral	p5 – hyporhithral	p6 – epipotamal	p7 – metapotamal	FRI - index	FRI - index variance
Brown trout	40%	40%	20%	-	-	<b>3.8</b>	0.62
Grayling	-	20%	60%	20%	-	<b>5.0</b>	0.44
Danube Salmon	-	-	30%	70%	-	<b>5.7</b>	0.23
Pikeperch	-	-	-	30%	70%	<b>6.7</b>	0.23

(modified from Schmutz et al., 2000b)

**Fish guild number and composition**

*Guild, in the ecological sense, is „a group of species that exploit the same class of environmental resources in a similar way” (Root, 1967).*

Species are grouped in guilds based on some degree of overlap in their niches regardless of taxonomic relationships. Thus, the guild approach simplifies methodology of fish-based assessment of riverine ecological integrity. And the loss of a fish guild is a much more significant signal of river degradation than the loss of a single species.

**BOX 6.8**  
Fish Region-Index (FRI) - an example

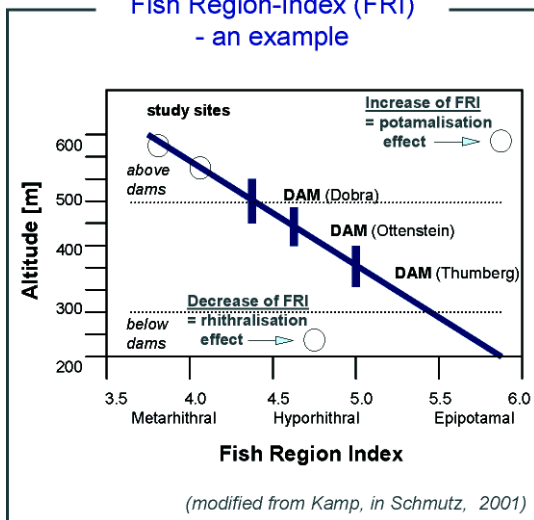

Guild classifications:

1. trophic (Table 6.4),
2. reproductive (Table 6.5),
3. habitat (Table 6.6),
4. residency/migration (Table 6.7),
5. tolerance (Table 6.8),
6. longevity and maturation (Table 6.9).

Guild composition is a commonly used criterion in bioassessment. For example, the Index of Biotic Integrity (Karr, 1981) is constructed upon fish trophic guild composition (Table 6.10 - 6.12).

**TABLE 6.4**  
Fish Trophic Guilds  
for North American freshwater fishes

TROPHIC CLASS	TROPHIC SUBCLASS	TROPHIC MODE
<b>Herbivores</b>	Particulate feeder	Grazer Browser
	Filter feeder	Suction feeder Filterer
<b>Detritivores</b>	Particulate feeder	Biters Scoopers
	Filter feeders	Mechanical sieve Mucus entrapment Ram filtration Pump filtration
<b>Planktivores</b>	Particulate feeders	Gulping Size-selective pickers
	Benthic predators	Grazers Crushers Hunters of mobile benthos Lie-in-wait predators
<b>Invertivores</b>	Drift predators	Tearers Diggers Surface feeders Water column feeders
	Whole body	Stalking Chasing Ambush Protective resemblance
<b>Carnivores</b>	Parasites	Blood suckers

(modified from Goldstein & Simon, 1999)

**TABLE 6.5**  
Fish Reproductive Guilds  
based on spawning habits

<b>I. NON GUARDERS</b>
<b>A. Open substrate spawners</b>
1. Pelagic spawners
2. Benthic spawners
a. Spawners on coarse bottoms
i. Spawners on coarse bottoms with pelagic larvae
ii. Spawners on coarse bottoms without pelagic larvae
b. Spawners on plants
i. Obligate spawners on plants
ii. Non-obligatory spawners on plants
3. Terrestrial spawners
<b>B. Brood hidiers</b>
1. Benthic spawners
2. Crevice spawners
3. Spawners on invertebrates
4. Beach spawners
<b>II. GUARDERS</b>
<b>A. Substratum choosers</b>
1. Rock tenders
2. Plant tenders
3. Terrestrial tenders
4. Pelagic tenders
<b>B. Nest spawners</b>
1. Rock and gravel nesters
2. Sand nesters
3. Plant material nesters
a. Gluemakers
b. Non-gluemakers
4. Froth nesters
5. Hole nesters
6. Miscellaneous-materials nesters
7. Anemone nesters
<b>III. BEARERS</b>
<b>A. External bearers</b>
1. Transfer brooders
2. Auxillary brooders
3. Mouth brooders
4. Gill-chamber brooders
5. Pouch brooders
<b>B. Internal bearers</b>
1. Facultative internal bearers
2. Obligate internal bearers
3. Live bearers

(modified from Balon, 1975; 1981 a,b)

For the European fish communities the original American IBI should be modified (Table 6.11). The main effects of river degradation on fish communities in the context of the IBI index are summarized in Table 6.13.

**TABLE 6.6**  
Fish Habitat Guilds

<b>RHEOPHILIC</b>	prefer to live, feed and reproduce in a habitat with high flow conditions, and clear water (e.g., trout)
<b>EURYTOPIC</b>	exhibit a wide tolerance of flow conditions, but generally not considered to be rheophilic (e.g., roach)
<b>LIMNOPHILIC</b>	prefer to live, feed and reproduce in a habitat with slow flowing to stagnant conditions (e.g., the key floodplain species)

(modified from Schiemer and Spindler, 1989)

**TABLE 6.8**  
Fish Tolerance Guilds

tolerance capacity of fish species to pollution and environmental degradation, depends on their genetic and physiological constrains	<b>TOLERANT</b> <b>INTERMEDIATE</b> <b>INTOLERANT</b>
--	---

**TABLE 6.9**  
Fish Longevity Guilds

live <5 years	<b>SHORT-LIVED</b>
live 5 – 15 years	<b>INTERMEDIATE</b>
live >15years	<b>LONG-LIVED</b>

### HOW RIVER DEGRADATION MAY AFFECT FISH POPULATION SIZE

#### Density and biomass

Fish population size (density and biomass) can reflect river degradation before these impacts start to limit the existence of fish species.

Human alterations can most often be detected as a decrease of population size. But an increase can also be observed (e.g., caused by eutrophication). The population size of a species should be characterized by quantitative measures - density and biomass per area or river length.

**TABLE 6.7**  
Fish Migration Guilds

<b>1. POTADROMY</b>	occurring entirely within the inland waters of a river system		
<b>2. DIADROMY</b>	occurring across a transition zone between fresh and marine waters	divided into three sub-categories:	<p style="text-align: center;"><b>ANADROMY</b> (<u>running up rivers</u>)</p> <p>refers to fishes that live as older juveniles and sub-adults in the sea but at maturity migrate up rivers to spawn, e.g., <i>Atlantic salmon</i></p>
			<p style="text-align: center;"><b>CATADROMY</b> (<u>running down rivers</u>)</p> <p>refers to fishes that have lived all their early life in fresh water – feeding and growing – but at maturity migrate down rivers to spawn in the sea, e.g., <i>eel</i></p>
			<p style="text-align: center;"><b>AMPHIDROMY</b> (<u>running between rivers and the ocean</u>)</p> <p>refers to fishes that spend appreciable parts of their life in both fresh and sea waters, feeding and growing in both, and whose migrations seem to have no direct relationship to reproduction</p>

**TABLE 6.10**  
Matrix of the original Index of Biotic Integrity (IBI)

CATEGORY	METRIC	SCORING CRITERIA		
		5	3	1
<b>Species richness and composition</b>	1. Total number of fish species	expectation for metrics 1-5 vary with stream size and region		
	2. Number and identity of darter species			
	3. Number and identity of sucker species			
	4. Number and identity of sunfish species			
	5. Number and identity of intolerant species			
<b>Trophic composition</b>	6. Proportion of individuals that are green sunfish	<5%	5-20%	>20%
	7. Proportion of individuals that are omnivores	<20 %	20-45%	>45%
	8. Proportion of individuals that are insectivorous cyprinids	>45%	20-45%	<20%
	9. Proportion of individuals that are piscivores (top carnivores)	>5%	1-5%	<1%
<b>Fish abundance and condition</b>	10. Number of individuals in sample	expectation for metric 10 vary with stream size and sampling methods		
	11. Proportion of individuals that are hybrids	0%	>0-1%	>1%
	12. Proportion of individuals with externally evident disease, parasites, or other anomalies	<2%	2-5%	>5%

(modified from Karr 1981)

**TABLE 6.11**  
Matrix of the original and modified version of the Index of Biotic Integrity (IBI)

Original Fish IBI (USA)	General Fish IBI
1. Number of fish species	1. Number of native fish species
2. Number of darter species	2. Number of riffle-benthic insectivores
3. Number of sunfish species	3. Number of water column insectivores
4. Number of sucker species	4. Number of pool-benthic insectivores
5. Number of intolerant species	5. Number of intolerant species
6. Relative abundance of green sunfish	6. Relative abundance of individuals of tolerant species
7. Relative abundance of omnivores	7. Relative abundance of omnivores
8. Relative abundance of insectivorous cyprinids	8. Relative abundance of insectivorous species (specialized insectivores)
9. Relative abundance of top carnivores	9. Relative abundance of top carnivores
10. Number of individuals	10. <i>Not a reliable metric</i>
11. Relative abundance of hybrids	11. <i>Not often used successfully</i>
12. Relative abundance of diseased individuals	12. Relative abundance of diseased individuals

(modified from Karr, 1981)

**TABLE 6.13**  
How river fish communities may change with environmental degradation (in context of the IBI index)

1.	DECLINE of the number of all native species and those of specific taxa or habitat guilds
2.	DECLINE of the number of intolerant species
3.	INCREASE of the proportion of tolerant species
4.	DECLINE of the proportion of trophic specialists (top carnivores, insectivores)
5.	INCREASE of the proportion of trophic generalists (omnivores)
6.	DECLINE of fish abundance
7.	DECLINE of the proportion of reproductive guilds requiring silt-free spawning substrate
8.	INCREASE of the possibility of hybridization
9.	INCREASE of disease, parasites, and morphological anomalies
10.	INCREASE of the proportion of introduced species

(modified from Fausch et al., 1990)

**TABLE 6.12**  
Integrity class of the original Index of Biotic Integrity (IBI)

TOTAL IBI SCORE	INTEGRITY CLASS
58 - 60	Excellent
48 - 52	Good
40 - 44	Fair
28 - 34	Poor
12 - 22	Very poor
	No fish

(modified from Karr 1981)

### HOW CAN RIVER DEGRADATION AFFECT FISH REPRODUCTIVE SUCCESS AND RECRUITMENT?

#### Population age structure

Larval and juvenile life stages are often more sensitive than adults to riverine degradation. Thus, reproductive success and recruitment is essential information in river assessments.

The easiest way to assess reproduction might be done by analyzing length-frequency-plots of the population age structure.

**HOW TO MONITOR A RIVER FOR FISH-BASED RIVER ASSESSMENT**

The concept of fish-based assessment of river quality requires frequent monitoring of the changes in fish communities due to degradation.

**How to sample fish?**

Electrofishing is world wide tested a very efficient qualitative and quantitative method of fish capture (Cowx and Lamarque 1990). Is possible to catch fish by alternating current (AC), pure direct current (DC) and pulsed direct current (PDC). The main idea of fishing with electricity is based upon the fact that first an electric current attracts fish to the anode (anodic galvanotaxis) and latter reduces fish motion thus makes them easy to catch by net. According to the recent standards (CEN/TC 230/WG 2/TG 4 N 27), either DC and PDC types of electric current may be used, but AC as too harmful for fish should not be anymore considered.

Electrofishing equipment includes: power generator, power conditioner, cathode and one or more anodes (Box 6.9).

Two sampling methods depending on river width and depth should be used (Box. 6.10):

- ▶ electrofishing by wading (in small, wadable rivers, usually with 1 anode);
- ▶ electrofishing from the boat (in medium size and large rivers, usually 2-3 anodes).

**Factors affecting the efficiency of electrofishing**

Three groups of factors that affect the efficiency of electrofishing can be selected (modified from Zalewski & Cowx 1990) as shown in the table 6.14.

**How is the efficiency of electrofishing estimated?**

Results from world rivers of different size and character are shown that the catch-effort electrofishing methods, which are most often employed for estimates of riverine fish density and biomass, are not very precise. Moreover, the multiple electrofishing sampling is both time and manpower-consuming, and what is most important can change both the river habitat and the fish community structure. For above reasons a different fishing procedure can be proposed both to minimize the

**BOX 6.9**  
**Electrofishing equipment**

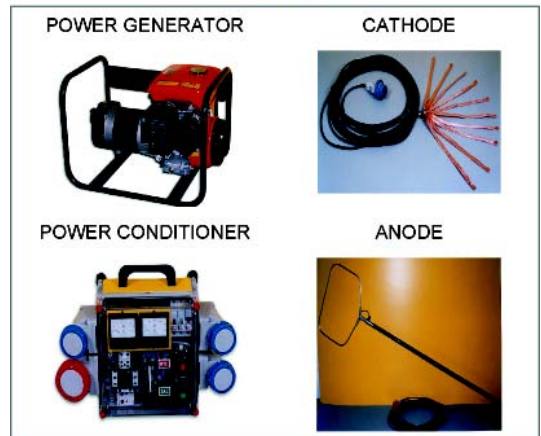

negative effects of electrofishing and to get sufficient results. This approach described by Zalewski (1983) is based on the results collected from different size and character rivers which showed

**TABLE 6.14**  
**Groups of factors affecting electrofishing**

<b>ENVIRONMENTAL</b>
<b>Abiotic:</b> conductivity (linear relationship), water quality and clarity
<b>Habitat:</b> structure, dimension, bottom substrate, water velocity
<b>Seasonality:</b> temperature, weather
<b>BIOLOGICAL</b>
<b>Community structure:</b> taxocene structure, species diversity and composition
<b>Population structure:</b> density, fish size, age structure, species specific behaviour, physiology, colour and morphology
<b>TECHNICAL</b>
<b>Personel:</b> size of crew, crew experience, motivation and ability
<b>Equipment:</b> design and maintenance
<b>Organisation:</b> site selection, standardization of effort

a curvilinear relationships between the average specimen size and the percentage, number and biomass of fish caught during the first electrofishing (Box 6.11 A, B).

The equation is highly applicable for small and medium size rivers. Above equation was confirmed by data from large polish rivers (Penczak & Zalewski, 1973). A section of the 30 m width and 2 m

of average depth river was carefully closed by fake nets and then multiple electrofishing was performed from the boat. Fish capture by fyke nets were considered as analogous to those that can be killed by rotenone treatment which could not be used in this size of river for verification. Two different morphologically river sections were sampled: first a concave bank of meander, and the second the convex bank, more diverse habitat with well developed riparian vegetation in form of overhanging willow branches. The differences in habitat accessibility resulted in about 76% of fish captured during first electrofishing in more uniform river meander and only 51% of fish captured in the convex bank habitat.

In the case of large rivers, the difficulties with application of above method are caused by the variable efficiency of electrofishing in narrow and wide river sections. Thus, two approaches could be proposed: first to divide the wide section into a separate channels with nets, and the second to increase the number of boats and the crew.

### BOX 6.10

#### Sampling methods in rivers – electrofishing



(photo: Schmutz, 2001)

#### How large sample is required?

The size of the sample should be sufficient to include the home range of the dominant fish species, and encompassing complete sets of the characteristic river form (e.g., pools, riffles, runs) to ensure a good representativeness of the fish community (CEN/TC 230/WG 2/TG 4 N 27)

In order to ensure accurate characterization of a fish community at a given site, the minimum river or stream length to be sampled by electrofishing must be at least 20 times the stream (or river) width (Angermeier & Karr, 1986).

### BOX 6.11

#### Relationship between efficiency of electrofishing and log mean weight of fish (A) and mean fish size (B)

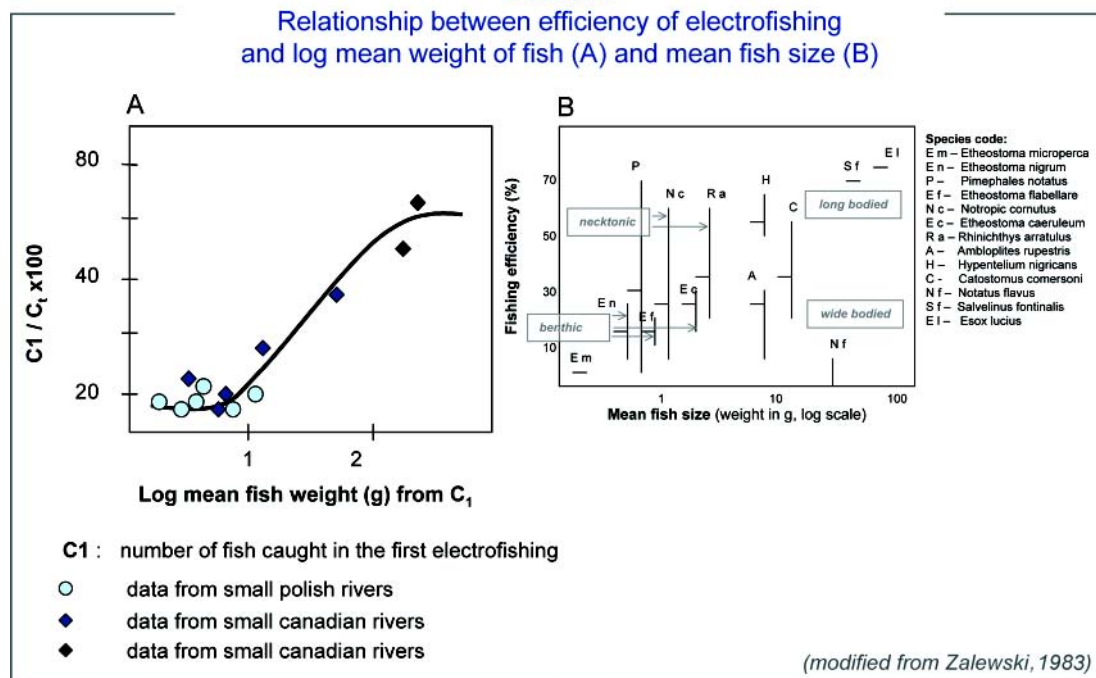

(modified from Zalewski, 1983)

#### MAKE SURE TO CHECK THESE RESOURCES:

Guidelines: chapters 6, 9

## ■ 6.C. BACTERIA, FUNGI AND MICROBIAL PROCESSES

Microbial processes are of great importance in the functioning of all water ecosystems.

Results of microbial analyses provide information on rates of decomposition and nutrient cycling in the environment. They give the degree of water contamination, when used as indicators of the sanitary state of watersheds.

Objectives of this chapter are to present specific requirements for microbial sampling and an overview of available methods for microbial analyses from the point of view of their importance for water quality and self-purification.

### WHAT IS THEIR ROLE IN THE ENVIRONMENT?

#### Bacteria...

Bacteria are the most common and ubiquitous single cell organisms with a great environmental importance. In terms of their metabolism, two groups of bacteria can be specified:

- ▶ **Autotrophic** - organisms that obtain energy from sunlight or oxidation of chemical compounds. One photosynthetic bacterial group is the cyanobacteria that are common in contaminated watersheds and produce dangerous blooms (see Guideline, chapter 8);
- ▶ **Heterotrophic** - organisms that use organic matter as a nourishment source after enzymatic transformation and chemical oxidation. This group is responsible for decomposition processes. They are a crucial element in environmental **nutrient regeneration** cycles of both inorganic and organic **compounds**.

Bacteria play crucial roles in carbon, oxygen and nitrogen cycling in biogeochemical processes through **production and decomposition** of organic matter.

*Bacteria are commonly used in biotechnology and bioremediation. However, their pathogenic activities cause human and plant diseases.*

#### Fungi...

Fungi are ubiquitous and much diversified organisms. Fungi are found in fresh water, marine water, and terrestrial habitats including soil, where they are extremely numerous.

- ▶ fungi associated with dead plant matter are important in **cycling of organic matter**, par-



Fig. 6.3  
Bacterial plates  
(photo: A. Trojanowska)

ticularly in **degradation** of plant polymers, such as cellulose and lignin, as well as other complex organic molecules.

- ▶ fungi are very effective in **bioremediation of heavy metals** and cyclic hydrocarbons (see Guideline, chapter 5). They affect plants beneficially through mycorrhizal associations by assisting in nutrient absorption.

### COLLABORATION BETWEEN BACTERIA AND FUNGI

Heterotrophic bacteria and fungi act in collaboration creating an efficient system of organic matter decomposition, the so called „**microbial loop**” (Box 6.12).

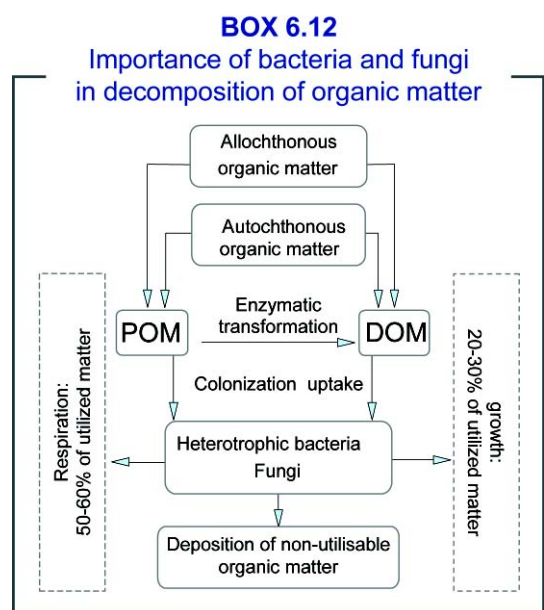

This system is responsible for organic matter transformation and mineralization and also liberates inorganic nutrients that are readily available for primary producers. At the same time, microorganisms are utilized by grazers as a food source.

Microbial process rates in fresh waters depend on several abiotic parameters:

- ▶ **dissolved oxygen concentration** - decomposition consumes oxygen; a decrease of  $O_2$  concentration below 0,1-0,5  $mg\ L^{-1}$ , can cause rapid depletion of microbiological process rates.
- ▶ **temperature** - at approximately  $0^\circ C$ , the biochemical oxygenation of hard to mineralize organic compounds is nearly stopped. In general, microbial process rates are temperature dependent. However, several species are adapted to work effectively in exceptionally low or high temperature or other extreme conditions.

- ▶ **pH** - very sensitive to drastic pH changes.
- ▶ the activity of microbial populations depends on the **amount and availability of organic matter**. In some aquatic systems they have been shown to be limited by the availability of inorganic nutrients, especially phosphorus. The total number of microorganisms and their activity (production and respiration) increase together with rising trophic status of ecosystems (Tab. 6.15). In general, the highest values of total bacterial number, as well as their activity, are observed during summer in highly productive ecosystems. However, much higher microbial population densities are observed in sediments (2-3 cm of surface layer) than in water columns.

**TABLE 6.15**  
Population density, production and respiration rates of bacterioplankton in different systems across the trophic gradient

		DENSITY		PRODU- CTIVITY P	RESPIRA- TION R
		N	B		
<b>hypertrophic</b>	Polluted coastal lagoons	10-40	2000-10000	500-3000	600-50000
<b>eutrophic</b>	Coastal lagoons, marine bays, lakes	5-10	2000-3000	500-1500	600-1700
	Lakes	3-8	600-2000	300-800	380-900
<b>mesotrophic</b>	Internal seas, lagoons, freshwater lakes	1,5-3,0	200-400	100-300	150-400
	Temperate oceanic regions	1,0-2,0	100-300	50-200	100-300
	Antarctic waters (summer-autumn)	1,0	-	-	-
<b>oligotrophic</b>	lakes	0,5-0,8	40-70	15-50	20-60
	Tropical oceanic waters	0,1-0,4	10-30	10-40	15-50
	Intermediate Antarctic waters in the Pacific Ocean	0,1-0,2	10-20	3-5	4-6

N- total number of bacteria ( $10^6\ cell\ ml^{-1}$ ), B – biomass of bacterioplankton ( $mg\ m^{-3}$ ) and P – production per day ( $mg\ m^{-3}$ ), R – respiration of bacterioplankton  $\mu g\ O_2\ L^{-1}\ day^{-1}$

(Sorokin, 1999)



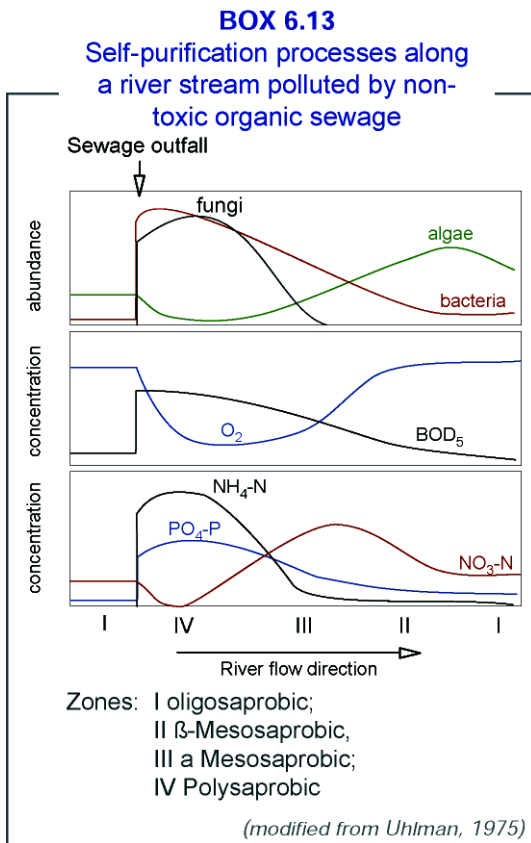

### Self-purification

Microbiological processes are crucial in terms of self-purification of river systems contaminated by domestic sewage. The **self-purification** process is the combined effect of dilution, sedimentation, absorption and biodegradation, which lead to water quality improvement along a stream.

Three main groups of microorganisms taking part in the self-purification process have been identified:

- ▶ **polisaprobic** - occupy highly contaminated zones with intensive decay processes;
- ▶ **mesosaprobic** - occupy moderately contaminated zones; and
- ▶ **oligosaprobic** - clean water organisms.

Their occurrence follows a gradient of decreasing contamination. This phenomenon is used for describing the degree of contamination and rate of self-purification processes along a river according to the saprobic zone classification (Box 6.13).

- ▶ **oligosaprobic (I)**: upstream of pollution, normal stream conditions, high DO, low BOD,

healthy fish, phytoplankton, benthos, periphyton;

- ▶ **polysaprobic (IV)**: strongly polluted zone, high bacterial density, very high community respiration, little or lack of photosynthesis, very high BOD, very low DO; fish, benthos, and phytoplankton absent; accumulation of organic particulates, community dominated by sewage fungi;
- ▶ **α-mesosaprobic (III)**: high contamination, organic matter being decomposed, community respiration dropping, phytoplankton and photosynthesis recovering, BOD dropping, DO dropping, may be anoxic at night;
- ▶ **β-mesosaprobic (II)**: mildly polluted zone, phytoplankton and macrophytes present, respiration and photosynthesis about equal, DO high, BOD low, biotic communities returning to normal.

The presence of high levels of organic contamination or toxic substances may weaken the condition of microbial communities, decrease their activity and cause self-purification process to be less effective. Self-purification is efficient if the rate of sewage inflow does not exceed a ratio of 1:50 in the receiving waterbody.

Extended buffering zones rich in macrophytes accelerate self-purification in rivers by increasing sedimentation of suspended matter and accumulation of high nutrient loads in plant biomass, which leads to effective elimination of organic contaminants from water. Such systems enriched with macrophytes, according to the ecohydrology concept, are more resistant for anthropogenic stress in terms of increased ecosystem capacity.

### BACTERIA AND SANITARY STATE

Microbiological analyses are mostly applied to water sanitary state assessment, which is often a determinant criterion of water quality status. Such analyses are especially required in systems supplying drinking water and water for domestic uses because of the possibility of contamination with infectious microorganisms in case problems occur with the water treatment and/or distribution systems. Tests for detecting and enumerating indica-

tor organisms, rather than pathogens, are used. The density of the coliform group of bacteria is the principal indicator of water pollution and the safety of water for domestic uses.

### METHODS OF ASSESSMENT

#### How to take samples

Samples for microbiological examination must be collected in bottles washed in distilled water and sterilized. Keep bottles closed until they are fil-

led with sample. The volume of sample should be sufficient to carry out all tests required, preferably not less than 100 ml. Protect the bottles from contamination. Leave ample air space in the bottle (at least 2,5 cm) for adequate sample mixing prior to examination.

#### Holding time and storage conditions

Holding time for microbiological samples is only 6 hours (at 4°C) prior to examination or preservation.

**TABLE 6.16**  
Sampling methodology

WATER SYSTEM	SAMPLING METHODOLOGY
Potable water	Put samples directly into the sampling bottle. Open tap fully and let water run for 2-3 minutes. Reduce water flow to permit filling of the bottle without splashing.
Raw water supply	Place the sample directly into the sampling bottle. Obtain samples representative of the water that is the source of supply.
Surface water	Take samples from the surface by putting the bottle, neck downward, below the water surface. Turn bottle until neck points upward and mouth is directed toward the current. If there is no current created, move the bottle horizontally forward but not above the surface. Take care to avoid contact with bank, soil or stream bed. When sampling from a boat, always obtain the sample from the upstream side of a boat.
Bathing beaches	Collect samples from a depth of about 1 m in the swimming area directly by using the sampling bottles.

### BOX 6.14

#### Example of station locations for microbiological sampling

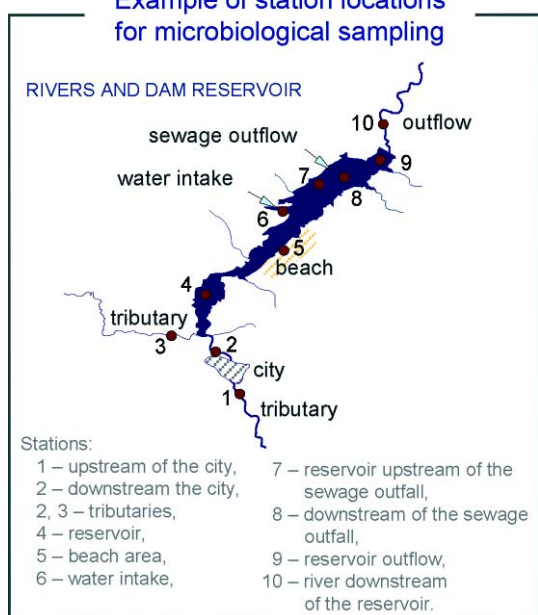

Preservation of samples in 4% final concentration of formaldehyde or ethanol (caution: formaldehyde is toxic - avoid inhalation, ingestion or contact with the skin) is suggested only for samples required for microscopic examination. Samples for examination using culturing methods should be preserved by the addition of a reducing reagent: sodium thiosulfate ( $\text{Na}_2\text{S}_2\text{O}_3$ ) to neutralize residual halogens and to prevent continuation of bactericidal action during sample transportation.

#### Where to take samples

To monitor stream or lake water quality establish sampling locations at critical sites.

Select bacteriological sampling locations to include a baseline location upstream from the study area, industrial and municipal waste outfalls into the main stream area, tributaries except those with a flow less than 10% of a main stream, intake

points for municipal or industrial purposes, downstream of wastewater outfalls and recreational areas. Notice that sampling downstream of wastewater outfalls should be preliminarily made in horizontal and vertical cross sections to determine the rate of contaminant dispersion (Box 6.14).

### Frequency of measurements

Frequency of sampling should be governed by the aim of a study. However, it is recommended to consider a seasonal model of sampling to take into account periods of drastic changes of environmental conditions such as hydrological patterns, temperature, and mixing.

The EPA monitoring requirements for sampling frequency for regulated microbiological contaminants vary depending on the type and size of the sys-

tem: seasonal for recreational waters and daily for water supply intakes. It is recommended to consider a geometric mean value of at least 5 samples taken over 30 days.

### Field and laboratory equipment

All the field and laboratory equipment used for microbiological examination should be washed thoroughly and sterilized.

### Sampling apparatus

To collect water samples from depths of a lake or reservoir, ZoBell or Niskin samplers are used. For bottom sediments a standard Van Donsel or any other similar sediment sampler constructed of stainless steel, is applicable.

**TABLE 6.17**  
Selected microbiological methods

<b>CULTURAL METHODS</b>	
<b>Heterotrophic Plate Count (HPC)</b>	Nutrient-poor or nutrient-rich plate or membrane filter method. Provides an approximate number of live heterotrophic bacteria. Number of colonies produced at 20°C in 24 hours is counted and expressed as colony forming units (CFU).
<b>Total Coliform bacteria</b>	Principal indicator of sanitary state, significance and interpretation of test is highly authenticated. Suggested for potable waters. Analysis includes the genera: <i>Escherichia</i> , <i>Citrobacter</i> , <i>Enterobacter</i> , <i>Klebsiella</i> . Estimation is made with a multiple-tube lactose fermentation test at 37°C over 24 to 48 hours or on membrane filters incubated on agar plates at 37°C for 24 h.
<b>Faecal Coliform bacteria</b>	Analysis includes the genus <i>Escherichia coli</i> . Test applicable to sanitary assessments of streams, raw water pollution and wastewaters. Estimation is made with a multiple-tube enriched lactose fermentation test at 44,5°C over 24 to 72 hours or on membrane filters incubated on agar plates at 44,5°C for 24 hours.
<b>MICROSCOPIC METHODS</b>	
<b>Direct microscopy counting</b>	Involves direct microscopic observations of microorganisms counted in a chamber (such as hemocytometer or Petrof-Hauser) that holds a specific volume of sample. There are special stains used for estimation of fungal and bacterial numbers (acridine orange). The results will be higher compared with cultural methods as a consequence of dead cells and cells not able to grow on culture plates being included.
<b>Epifluorescence microscopy</b>	Standard technique for estimation of total number of bacteria. Sample is treated with fluorochrome (DAPI, fluoresceine isothiocyanete) which is attached to DNA and easily seen as highly fluorescent spots in UV light. Counting is made on black filters after filtrating samples through them. Preserved samples can be stored for up to 6 months before processing.
<b>Advanced microscopic techniques</b>	Scanning confocal microscopy, polarization microscopy or electron microscopy might be used for advanced analyses of bacterial or fungal populations to determine cell structure and chemical composition, for example.

**TABLE 6.17 – cont**  
Selected microbiological methods

<b>MICROBIAL ACTIVITY ASSESSMENT METHODS</b>	
<b>Enzyme assays</b> (selected enzymes)	<p>Enzyme assays used for estimation of specific activity of microbial communities including bacteria, fungi, phytoplankton and actinomycetes:</p> <p><b>Dehydrogenase activity:</b> Responsible for oxidation-reduction reactions. Provides information about respiration of microbial communities. Estimation by spectrophotometric method with artificial substrates: Trifenyltetrazolium.</p> <p><b>Phosphatase activity:</b> Responsible for hydrolysis of organic compounds containing phosphorus. Provides information about phosphorus mineralization rates. Estimation by spectrophotometric or fluorometric methods with artificial substrates: p-NPP or MUFP (respectively).</p> <p><b>Aminopeptidase activity:</b> Responsible for hydrolysis of proteins with liberation of amino acids. Provides information about heterotrophic microbial activity. Estimation using a fluorometric method with artificial substrates: LAKM.</p> <p><b>Protease activity:</b> Responsible for hydrolysis of proteins. Measured by determination of residual protein in gelatine medium.</p> <p><b>Cellulase activity:</b> Responsible for hydrolysis of plant constituents, releasing monomeric sugar units. Measured by determination of mass loss of cellulose substrates.</p>
<b>Respiration</b>	<p>Indicates rate of organic compound decomposition</p> <p>Measured under anaerobic conditions by CO<sub>2</sub> or CH<sub>4</sub> production or in aerobic conditions by O<sub>2</sub> consumption.</p>
<b>Bacterial production rate</b>	<p>Indicates increase of number or biomass of bacterial population.</p> <p>Measured by: incorporation of radioactive labelled tracers into cellular macromolecules, i.e., thymidine into DNA or leucine into proteins.</p>

### Sample bottles

Use glass or plastic bottles than can be sterilized. For some applications pre-sterilized plastic bags might be used.

### Laboratory methods

There are several precise and quick methods currently available for:

- ▶ estimation of number of live microorganisms - cultural methods;
- ▶ direct counting of microorganisms - microscopic methods; and
- ▶ microbial activity assessments.

However, their limitations must be understood thoroughly (Table 6.17).

Microbial analyses should be done by a professional microbiologist or by a person who was specifi-

cally trained and is periodically supervised by a microbiologist.

### INTERPRETATION AND VERIFICATION OF RESULTS

Examination of routine bacteriological samples cannot be regarded as providing complete information concerning water quality. Interpretation of the results should be made in conjunction with chemical and toxicological results obtained at the same time.

**STANDARDS:**

Existing standards for microbiological testing regard only sanitary state indicators: total coliform, faecal coliform or faecal streptococci bacterial numbers. Remember: In spite of standard methods being used in microbial examination, different limits are used for sanitary state assessments in different countries.

**TABLE 6.18**

Example of microbiological numerical limits for water of different designations

TYPE OF WATER SYSTEM	LIMIT
Fresh water	126 per 100ml
Salt water	35 per 100ml
Recreational freshwater beach areas	235 per100 ml

Expressed as number of E. coli colony forming units per 100 ml (Faecal Coliform Bacteria).

Water Quality Standards Handbook, EPA-823-B-94-005a, August 1994, Second Edition (Maryland, USA)

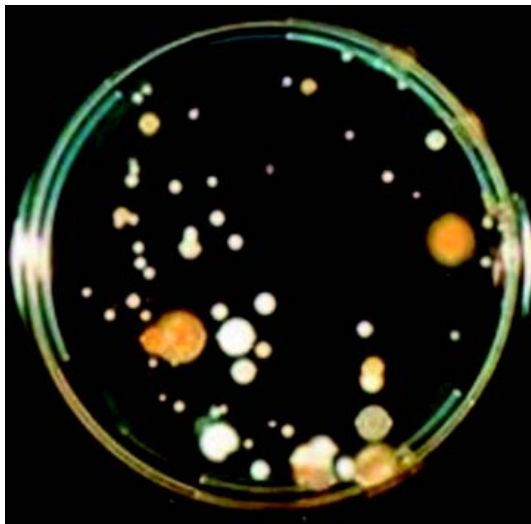

Fig. 6.4  
Bacterial and fungal colonies growing on a Petri dish containing nutrient rich medium (photo: Department of Applied Ecology)

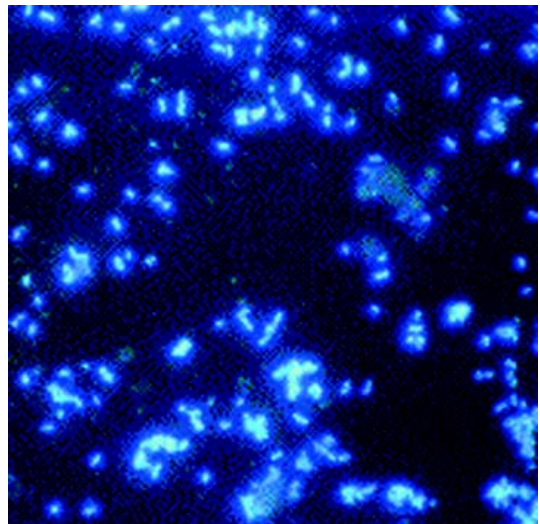

Fig. 6.5  
DAPI stained bacterial sample, prepared or counting using a fluorescence microscope (photo: Department of Applied Ecology)

**MAKE SURE TO CHECK THESE RESOURCES:**

Guidelines: chapters 5, 7.E, 7.G

## 7.A. WHAT HAPPENS TO PHOSPHORUS IN A WATER BODY: SEDIMENTATION

Sedimentation of matter exported from catchments is one of the serious problems in man-made reservoirs.

Studies of the sediment surface layer provide information on the areas of enhanced sedimentation processes in reservoirs, as well as on the quality and quantity of recently deposited matter. Information obtained from analyses of surface sediments can be used to map the distribution of particular contaminants.

The objective of this chapter is to provide an overview of available methods for sampling and analysis of sediments from the point of view of identifying sedimentation areas and potential risk of internal load.

### WHY DO WE MEASURE SEDIMENTATION?

- ▶ inflow of solid particles, their sedimentation and deposition causes long-term siltation and decreased capacity of lakes and reservoirs;
- ▶ sediments are reservoirs of organic matter, nutrients (mainly phosphorus), as well as dangerous pollutants, such as pesticides, sulphides, ammonium and trace metals, which affect water quality and can cause lethal or sub-lethal effects in benthic communities;
- ▶ sediments play an important role in internal loading due to the release of retained nutrients, which can become available to phytoplankton; and
- ▶ sediments also provide habitat, feeding and spawning areas for many aquatic organisms.

### PROCESSES OF SEDIMENT TRANSPORT AND DEPOSITION

Sediment transport and deposition is a dominant process in reservoirs that significantly influences the ecological state of the ecosystem. Sediment amount, delivery and intensity of its deposition depend on:

- ▶ shape, location and land use in the catchment area that determine erosion;
- ▶ hydraulic conditions: hydrological pattern, especially storm events, elevated flows and wind action; and
- ▶ stream order that determines the amount of allochthonous and autochthonous matter.

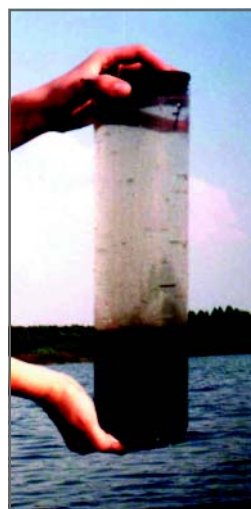

Fig. 7.1  
A sediment sample taken by a coring sampler  
(photo: I. Wagner-Lotkowska)

The types of matter delivered and deposited with decreasing size of particles are:

- ▶ **inorganic particles:** sand, silt, clay; and
- ▶ **organic particles:** Coarse Particulate Organic Matter (CPOM), Fine Particulate Organic Matter (FPOM).

Due to hydrological changes along a reservoir and through a lake, they exhibit longitudinal gradients in suspended sediment concentration, particle size distribution, and in consequence, chemical and biological gradients (Box 7.1).

The rate of deposition is generally higher in a river mouth than in open water areas and higher in lakes dominated by allochthonous, as opposed to autochthonous, matter (highly productive). The grain size of inorganic particles and their rate of deposition decreases longitudinally with the distance from the mouth of the tributary due to a decrease of water velocity.

In terms of the origin of allochthonous organic matter, CPOM dominates in river mouths and riverine zones of reservoirs. However, small particles of FPOM prevail in open waters of the lacustrine zone due to autochthonous algal biomass production.

In terms of sedimentation importance for water quality and capacity of reservoirs, estimation of sedimentation rate and areas of material deposition are highly recommended.

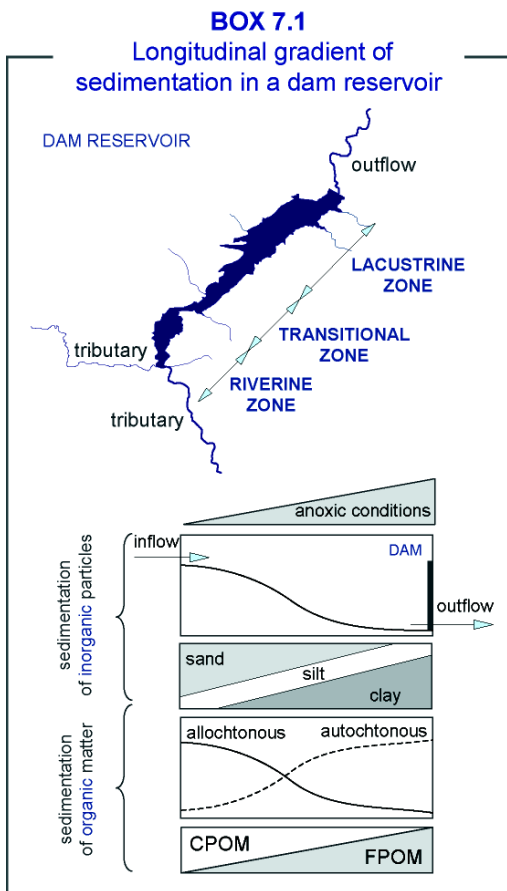

### EXCHANGE OF NUTRIENTS BETWEEN WATER AND SEDIMENTS

The surface layer of sediments (<5 cm) is characterized by extremely intensive physical, chemical and biological processes of organic matter transformation resulting in:

- ▶ durable bonding of nutrients and their retention; and
- ▶ liberation of nutrients to interstitial water and transport to the overlying water.

These processes are strongly dependent on water mass stability, temperature and redox potential.

Fluctuating water levels **enhance sediment-water interactions** in reservoirs and results in increased nutrient transport from sediments to the water column. Sudden bottom water movement due to wind mixing or discharge increases, as well as biological **activity of benthic organisms**, cause **resuspension** of deposited particles and facilitate the **return of nutrients** to the overlying wa-

ter. Similar effects occur at the water-sediment interface in anoxic conditions, which are observed during high temperature periods in nutrient rich ecosystems or in nutrient-poor tropical and sub-tropical systems. When the oxygen concentration decreases to below 2 mg L<sup>-1</sup> (redox potential <200mV) phosphorus, iron, magnesium and ammonia are liberated and transported to the overlying water. The above processes of internal loading significantly contribute to increased nutrient availability for algae and cyanobacteria.

### METHODS OF ASSESSMENT

#### How to collect the samples

- ▶ sample **volume** should be obtained by consulting with a testing laboratory to confirm the amount of sediment required for analysis. If full biological, toxicological and biological testing is required, at least 10 litres of sediment might be required from each station;
- ▶ consider taking **integrated** samples from a given station or across similar station types to reduce the number of samples needed;
- ▶ additional field observations and measurements are important when sediment sampling:
  - coordinates;
  - oxygen concentration measured at the sediment-water interface; and
  - pH and temperature in water overlying the sediments.
- ▶ to minimize measurement error:
  - sample all stations similarly within a study;
  - use standardized procedures;
  - sample during the same time period; and
  - collect and analyse multiple samples at a station.

#### Where to collect the samples

Design a sampling net relevant to the aim of the study. The following types of sampling systems can be distinguished:

- ▶ **deterministic system**: based on given information or purposes, usually denser in areas of special interest;
- ▶ **stochastic**: based on random sampling;

**BOX 7.2**  
Examples of different  
sampling systems

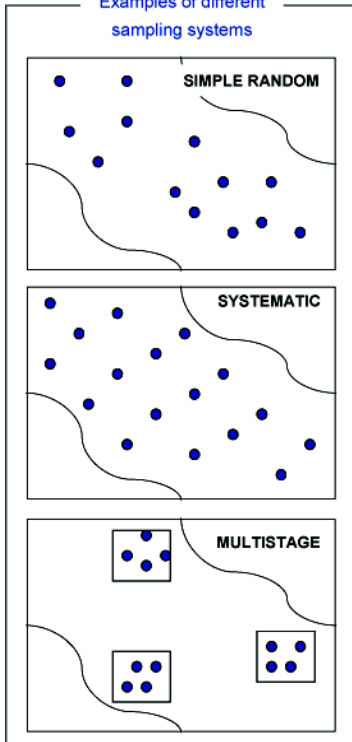

**BOX 7.3**  
Examples of commonly used  
grab sediment samplers

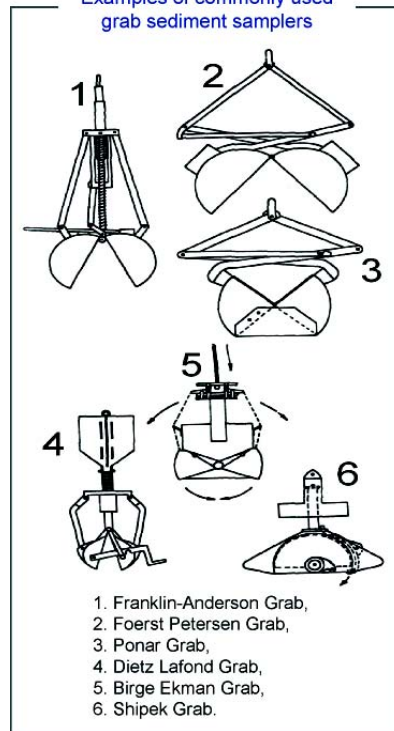

- ▶ **regular grid system:** which can be placed randomly or deterministically on a lake (Box 7.2)

Furthermore, the selection of sampling sites should take into consideration the location of critical points affecting sediment quality:

- ▶ sediment depositional zones;
- ▶ tributaries;
- ▶ water intake areas;
- ▶ sewage outfalls; and
- ▶ location of historical sampling stations.

### Frequency of measurements

Frequency of sampling should be governed by the study aims. However, it is recommended to consider a seasonal model of sampling with respect to periods of drastic changes of hydrological pattern, including floods, storm events, elevated flows and droughts.

### Sediment samplers

A large number of sediment samplers have been designated for specific purposes and for sampling in different environments. Most sediment samplers

**BOX 7.4**  
Various types of core samplers

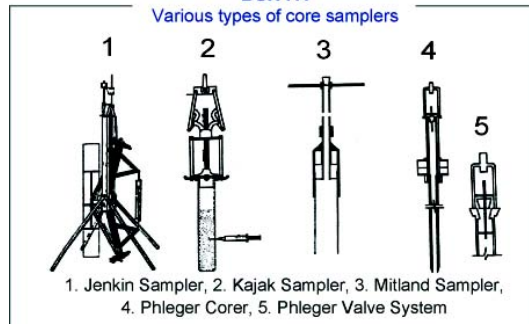

can be classified as core (does not disturb sediment profile) or grab samplers (Box 7.3, Box 7.4). In most cases special decontamination of sampling equipment is not required; rinsing in water between sampling stations should be enough. However, if at least one of many sampling stations is heavily contaminated, it might be necessary to decontaminate all sampling devices using the following steps:

- ▶ washing in soap and water;
- ▶ rinsing in distilled water;
- ▶ rinsing in acetone or ethanol; and
- ▶ rinsing in site water.



**Sediment traps**

Sediment traps are used for measuring sedimentation rate. Usually several traps, such as cylinders, bottles or funnels, are submerged to collect sedimenting particles over a certain time period (Box 7.5).

**Sample containers**

Borosilicate glass, high density polyethylene (HDPE) or polytetrafluoroethylene (PTFE) containers are suitable for most analytical measurements. All containers should be pre-cleaned prior to filling with the sample. Purge containers with

inert gas (nitrogen) prior and after filling if anoxic conditions must be maintained. Fill containers completely if the sample will not be frozen.

**Methods**

Assessment of the physical-chemical quality of sediments, combined with toxicity testing, is often the most frequently required information. Chemical analyses should be done by qualified chemists in a professional chemical laboratory.

**Sample transport and storage**

The volume of overlying water should be minimized to reduce potential resuspension. Samples should be secured to avoid sample disturbance. According to general recommendations, collected sediment samples should be stored in containers without a headspace at 4°C in the dark to minimize changes in contaminant bioavailability. However, preservation and storage times for samples designed for various types of analyses are different (Appendix 1).

Examples of field forms for sediment sampling are given in Appendix 2.

**Interpretation and verification of results**

Different standards and different limits are used in different countries for assessment of sediment quality and sanitary state. The most frequently used parameter for sediment quality characterization are the contents of trace metals and organic cyclic compounds.

As an example, Appendix 3 presents selected parameters and standards according to the USEPA.

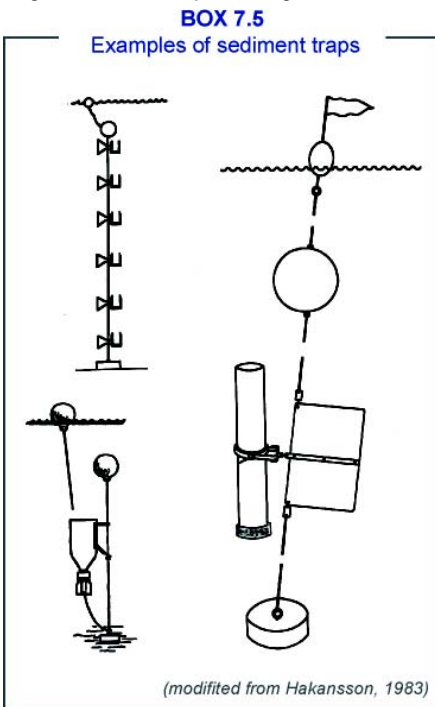

**TABLE 7.1**  
General considerations for core and grab samplers usage

USE A CORE SAMPLER IF:	USE A GRAB SAMPLER IF:
<ul style="list-style-type: none"> <li>- Characterization of contamination in deeper sediments is important</li> <li>- Comparison of recent surficial and historical deeper sediments is intended to be done</li> <li>- Reduced sediment gradient disruption needed</li> <li>- Reduced oxygen exposure needed</li> <li>- Sediment is soft and fine grained</li> </ul>	<ul style="list-style-type: none"> <li>- Large sediment volumes needed</li> <li>- Larger grained sediments are common</li> <li>- Larger surface area of surficial sediment needed</li> </ul>

**MAKE SURE TO CHECK THESE RESOURCES:**

Guidelines: chapters 7, 8.A

## 7.B. WHAT HAPPENS TO NITROGEN IN A WATER BODY: DENITRIFICATION

Nitrogen is one of the factors limiting algal growth in rivers and lakes. The principal requirement of living cells for nitrogen is synthesis of aminoacids and proteins. Nitrogen surplus causes eutrophication, but also such environmental problems as acid deposition, global warming and depletion of the ozone layer. Because of the gaseous cycle, methods of nitrogen control are different from those for phosphorus and other nutrients. The objective of this chapter is to present methods of assessment for the rate of N-cycling in fresh water.

### THE MAJOR FORMS OF NITROGEN IN FRESHWATER ECOSYSTEMS

Nitrogen is present in fresh water in many forms (Box 7.6, see guidelines: chapter 7.G). However, only the reduced form ( $\text{NH}_2$ ) can be built into organic macromolecules, mainly amino- and nucleic acids. After carbon and oxygen, nitrogen is quantitatively the most abundant compound in organisms, constituting 15-20% of their dry weight.

#### BOX 7.6

What are the forms of nitrogen in fresh waters?

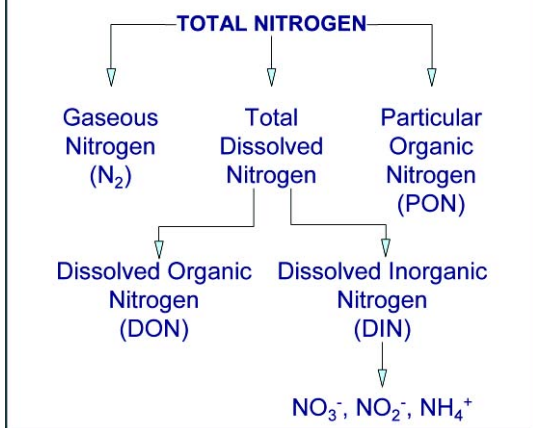

Nitrogen fixation brings N from the atmosphere into the biosphere and denitrification returns N to atmospheric  $\text{N}_2$ . Due to disturbances of the N-fixation/denitrification balance, the turnover of higher amounts of  $\text{NO}_3^-$  to  $\text{N}_2\text{O}$  will further destroy the ozone layer to the stratosphere and extend the greenhouse effect.



Fig. 7.2  
The process of denitrification occurs intensively in anaerobic environments of oxbows and floodplains (photo: B. Sumorok)

### MAN-MADE SOURCES OF NITROGEN

The main sources of nitrogen contamination are:

- ▶ transboundary atmospheric pollution (acid rain);
- ▶ oil pollution;
- ▶ agricultural ground water pollution, resulting mostly from nitrate fertilizer use;
- ▶ faecal contamination; and
- ▶ domestic and industrial sewage water pollution.

### WHAT ARE THE EFFECT OF NITROGEN ENRICHMENT?

The enrichment of soil and surface waters with nitrate may endanger the balance of the natural environment or even restrict environmental resources from use due to the accumulation of toxic nitrite products. The most dangerous effects of nitrogen enrichment include:

- ▶ **toxic algal blooms**, appearance of which may restrict use of freshwater resources; and
- ▶ **temporal accumulation of nitrate**, the consumption of which in potable water can cause infant methemoglobinemia (blue baby syndrome).

*According to WHO recommendations, the maximum allowable concentration of nitrate nitrogen in potable water, should not exceed  $10 \text{ mg L}^{-1}$  (WHO, 1971).*

### THE ROLE OF SEDIMENTS IN NITROGEN CYCLING

Bentic metabolism plays an important role in the regulation of nutrient concentrations and, thus, the productivity of ecosystems. In the case of ni-

trogen, depending on the physical and chemical parameters, sediments can be both a source as well as a major sink in the cycle of this element. The regeneration of ammonium in sediments is a major source of nitrogen to the water column, whereas production of dinitrogen gas (denitrification) and burial are major nitrogen sinks. Most of the organic matter reaching the sediments is microbially degraded in the ammonification process. Box 7.7 presents a schematic illustration of the nitrogen cycle in sediments. The name of different N-cycle processes are in *italics>*.

**WHY DO WE MEASURE DENITRIFICATION?**

The denitrification process is responsible for removing nitrogen from wastewater and eutrophicated reservoirs and lakes. The process may be additionally enhanced by regulation of the physical characteristics of the site. Therefore, it can be used for nitrogen removal from rivers, lakes and reservoirs, as well as in transitional land-water zones. It is important to identify areas of intensive denitrification in order to control the process for nitrogen removal (Table 7.2).

**TABLE 7.2**  
Main nitrogen transformations in water

PROCESS	PATHWAY	REGULATED BY	ORGANISMS TAKING PART IN THE PROCESS:
Assimilatory nitrate reduction	$\text{NO}_3^- \rightarrow \text{NO}_2^- \rightarrow \text{NH}_4^+$	$\text{NH}_4^+$ , organic N	plants, fungi, algae, bacteria
Denitrification	$\text{NO}_3^- \rightarrow \text{NO}_2^- \rightarrow \text{N}_2\text{O} \rightarrow \text{N}_2$	$\text{O}_2$ , organic C	aerobic bacteria also capable of anaerobic growth with $\text{NO}_3^-$ or $\text{NO}_2^-$
Dissimilatory nitrate reduction to ammonium (Ammonification)	$\text{NO}_3^- \rightarrow \text{NO}_2^- \rightarrow \text{NO} \rightarrow \text{NH}_2\text{OH} \rightarrow \text{NH}_3$	$\text{O}_2$ , organic N	anaerobic and facultatively anaerobic bacteria (for example, <i>Bacillus</i> sp., <i>Aerobacter</i> sp.,)
Nitrification	$\text{NH}_3 + 1,5\text{O}_2 \leftrightarrow \text{NO}_2^- + \text{H}^+ + \text{H}_2\text{O}$ $\text{NO}_2^- + 0,5\text{O}_2 \leftrightarrow \text{NO}_3^-$	$\text{O}_2$ , inorganic C ( $\text{CO}_2$ , $\text{HCO}_3^-$ )	bacteria ( <i>Nitrosomonas</i> spp., <i>Nitrobacter</i> spp.)
$\text{N}_2$ biological fixation	$\text{N}_2 + 3\text{H}_2 \rightarrow 2\text{NH}_3$ $2\text{CO}_2 + \text{H}_2\text{O} + \text{NH}_3 \rightarrow \text{CH}_2\text{NH}_2\text{COOH}$	Enzyme system: <i>nitrogenase</i> ; under anoxic conditions	Prokaryota: cyanobacteria, bacteria

**BOX 7.7**  
Main nitrogen transformations in water

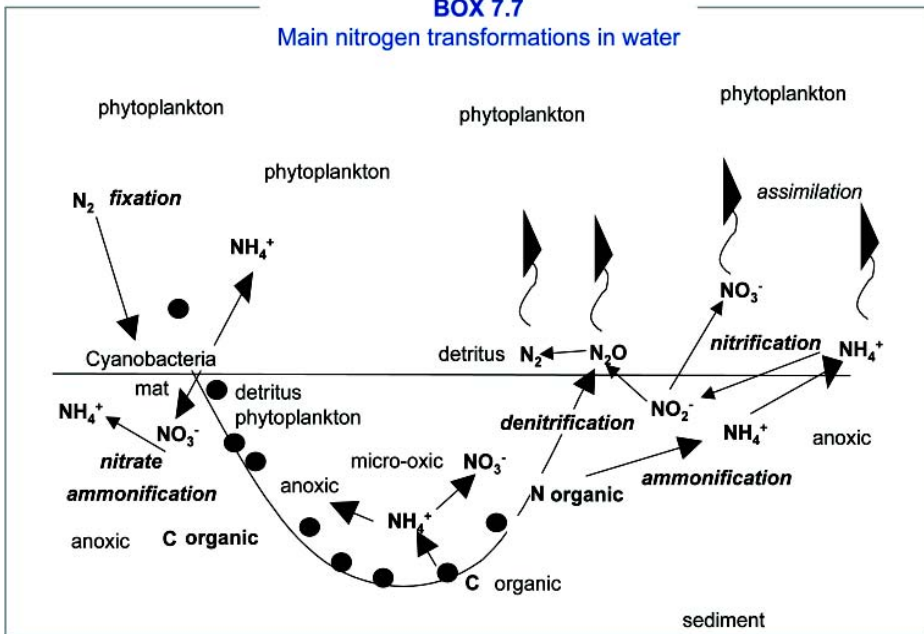

**TABLE 7.3**

Summary of methods used to measure denitrification activity

METHOD	ANALYSIS	WHERE USED	COMMENTS
<b>Acetylene inhibition – N<sub>2</sub>O production</b>	Gas chromatography	Natural samples of all types; microbial cultures	The most popular method because of its sensitivity, capacity for large number of samples, simplicity, low cost, and does not require any addition to the natural NO <sub>3</sub> <sup>-</sup> pool. Its limitation is that acetylene also inhibits nitrification and thus will reduce the denitrification rates in samples where NO <sub>3</sub> <sup>-</sup> is very low.
<b>N<sub>2</sub> production</b>	Gas chromatography	Microbial cultures; used for natural samples	Because of large N <sub>2</sub> background in the atmosphere – the sample atmosphere has been exchanged for another gas (e.g., He). The sample must be very active for detection of denitrification over leaks, out-gassing, and relative insensitivity of the thermal conductivity detector.
<b>Consumption of NO<sub>3</sub><sup>-</sup> and NO<sub>2</sub><sup>-</sup></b>	Colourimetric methods, nitrate electrode, steam distillation, UV adsorption (direct or after HPLC)	Microbial cultures; aquatic habitats	Not considered definitive for denitrification since NO <sub>3</sub> <sup>-</sup> and NO <sub>2</sub> <sup>-</sup> can be reduced to NH <sub>4</sub> <sup>+</sup> . Can be used together with total NH <sub>4</sub> <sup>+</sup> + organic-N (mass balance), in which unrecovered N is equated to denitrification. The method is relatively insensitive and works best when N <sub>tot</sub> in the sample is very low.
<b>NO<sub>3</sub><sup>-</sup> / Cl<sup>-</sup> (Br<sup>-</sup>) ratio</b>	Colourimetric methods, specific ion electrodes,	Soil	Both anions have the same mobility in natural systems, but only NO <sub>3</sub> <sup>-</sup> is consumed. The method is rather qualitative, but it has the advantage of requiring only a single measurement and it reflects the process as it occurred naturally.
<b>N<sub>2</sub> /Ar ratio</b>	Gas chromatography (thermal conductivity)	Marine water column	The method is not sensitive, but it directly reflects the process over a large scale in nature. N <sub>2</sub> consumption by fixation can confound this measurement, so it is usually not significant in the deeper water column where this method is used.

**TABLE 7.3 – cont.**

Summary of methods used to measure denitrification activity

METHOD	ANALYSIS	WHERE USED	COMMENTS
<p><b>Isotopic Methods</b> <b>The <sup>15</sup>N isotope</b></p>	<p>Mass spectrometry magnetic sector quadrupole UV emission</p>		<p>Mass spectrometry is the preferred analytical method. Isotope ratio instruments are designed for high precision measurements, but most require a large amount of N<sub>2</sub>. The quadrupole units are coupled to a gas chromatograph and have the ability to separate gases as well as detect much smaller amounts. The UV emission instrument is less expensive and requires only small amount of N<sub>2</sub>, but is much less precise.</p>
<p><b>Isotopic Methods</b> <b><sup>13</sup>N</b></p>	<p>β<sup>+</sup> liquid scintillation, proportional counter γ NaI (TI) detectors</p>		<p><sup>13</sup>N is the longest lived radioactive N isotope; It provides the greatest sensitivity of any denitrification method, but it can be used for only short periods, must be used near an accelerator, and requires expensive equipment. It is the only direct method to measure denitrification in the natural atmosphere.</p>
<p><b>Use of isotopes</b> <b>Labelled N-gas production</b> <b><sup>13</sup>N<sub>2</sub>, <sup>13</sup>N<sub>2</sub>O, <sup>28</sup>N<sub>2</sub>, <sup>29</sup>N<sub>2</sub>, <sup>30</sup>N<sub>2</sub></b> <b>Mass balance (loss of enriched <sup>15</sup>N or depleted <sup>14</sup>N nitrogen)</b></p>		<p>Natural sample, culture Natural samples, cultures</p>	<p>Isotopes can be used to improve the sensitivity and specificity of denitrification measurement. A limitation is that the isotope must be uniformly mixed with the natural pool over space and time and in amounts that will not increase the natural nitrate concentration.</p>
<p><b>Isotope dilution</b> <b>Using <sup>15</sup>N</b></p>	<p>Mass spectrometry</p>	<p>Natural samples</p>	<p>Isotope dilution to measure denitrification can be used by observing dilution of <sup>15</sup>N-enriched atmosphere or by the use of modelling in conjunction with the measurement of other N-cycle processes.</p>
<p><b>Microbiological method: occurrence of denitrifying bacteria</b></p>	<p>Determined by means of the most probable number (MPN) and plate counting (PC).</p>	<p>Sediments, surface waters, soils, wastes</p>	<p>The highest percentage of denitrifiers in relation to the total number of bacteria at selected environmental sites is found at stations where the content of organic carbon was also the highest.</p>

(modified from Tiedje, 1982)

## WHERE AND HOW SHOULD DENITRIFICATION BE MEASURED?

Table 7.3 presents summary of methods used to measure denitrification activity. The denitrification rate in natural samples should be measured in summer or early autumn. The measurement stations with the highest denitrification rates in the bottom sediments are located near islands and in bays of reservoirs where beneficial conditions arise from the accumulation of organic matter.

The most useful methods to measure denitrification in the field are:

- ▶ **the *in situ* chamber method** - the denitrification rate is calculated from the total  $N_2$  flux out of the sediment measured directly by gas chromatography (Box 7.8); and
- ▶ **occurrence of denitrifying bacteria** - determined by means of the most probable number (MPN) and plate counting (PC).

### In situ denitrification measurements

This method is the most useful for shallow, nutrient-rich reservoirs. The denitrification rate is measured in summer or early autumn and calculated from the total  $N_2$  flux out of the sediment and calculated as ( $\text{mol } N_2 \text{ m}^{-2} \text{ h}^{-1}$ ; Bednarek et al., 2001). Sediment cores are collected, dried and subjected to chemical analysis for organic matter, organic carbon and nitrogen as denitrification reac-

tion substrates. The results are calculated in  $\mu\text{g C g}^{-1}$  of dry weight of sediment.

### Microbiological analyses

For comparison of denitrification rates using the *in situ* chamber method, sediment samples for bacteriological testing should be collected at the same sampling stations.

### Bacterial numbers and isolation of denitrifiers.

Occurrence of denitrifying bacteria is determined by means of the most probable number (MPN) and plate counting (PC) methods (Gamble et al., 1977). Strains of denitrifying bacteria are isolated from a bacterial colony growing on nutritive agar. About 100 colonies from selected dilutions are replicated and tested for the presence of gaseous nitrogen during nitrite reduction in nutrient agar supplemented with  $345 \text{ mg NaNO}_2 \text{ L}^{-1}$ .

**Identification of denitrifying bacteria.** Identification of denitrifying bacteria is performed according to Grama's method, which produces fluorescently pigmented colonies on King's A and B media, from starch hydrolysis in the presence of cytochromium oxidases (Burzynska, 1964). API 20 NE (bioMerieux) is a standardized micro-method combining 8 conventional tests and 12 assimilation tests in prepared kits.

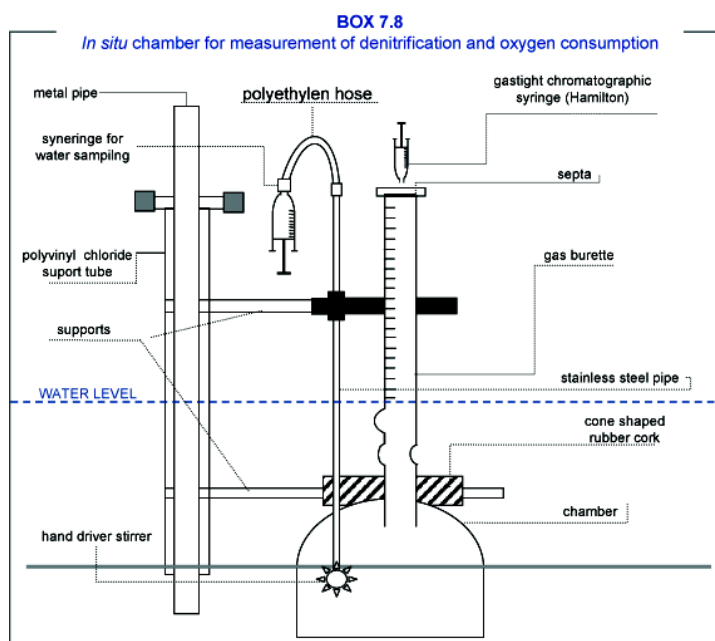

## 7.C. HOW TO ASSESS PHYTOPLANKTON BIOMASS?

Massive phytoplankton growths are one of the effects of eutrophication in lakes and reservoirs. This is because nutrient availability is a major factor limiting phytoplankton growth. Therefore, measurement of phytoplankton biomass is one of the parameters used to assess the trophic level of a water body. It is also a warning indicator about the possible appearance of toxic cyanobacteria.

The objective of this chapter is to outline methods for the quantitative assessment of phytoplankton and eutrophication levels using phytoplankton analysis.

### WHY SHOULD WE MEASURE PHYTOPLANKTON BIOMASS?

The structure of phytoplankton communities in aquatic ecosystems is dynamic and constantly changing during a growing season, both in species composition and biomass distribution. Many factors are responsible for phytoplankton succession (Box 7.9, Box 7.10):

#### ► abiotic factors

- temperature;
- irradiance;
- hydraulic throughput;
- mixing and stratification dynamics;
- water retention time;
- pollutants; and
- nutrient availability.

#### ► biotic factors

- selective predation by zooplankton;
- interspecies competition for limiting resources; and
- parasitic populations.

As a consequence of differences in latitude, climate and stratification patterns, phytoplankton succession may be different between different water bodies, even in one region. In the temperate and polar zones there is a great contrast between summer and winter and in the tropics between the rainy and dry seasons.

The phytoplankton communities in temperate lakes show seasonal variation with a minimum during winter. Maxima are reached during spring and fall mixing and, in many lakes, also during late summer (Box 7.9). In tropical water bodies, high phytoplankton biomass can occur throughout the year.

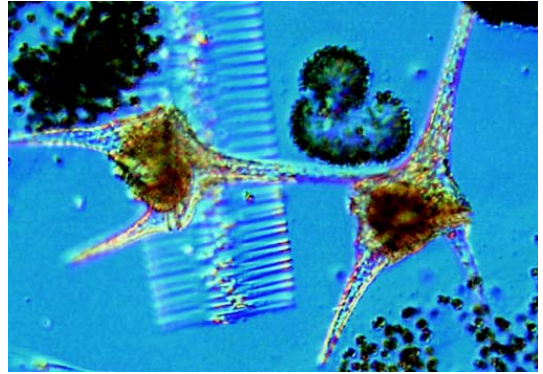
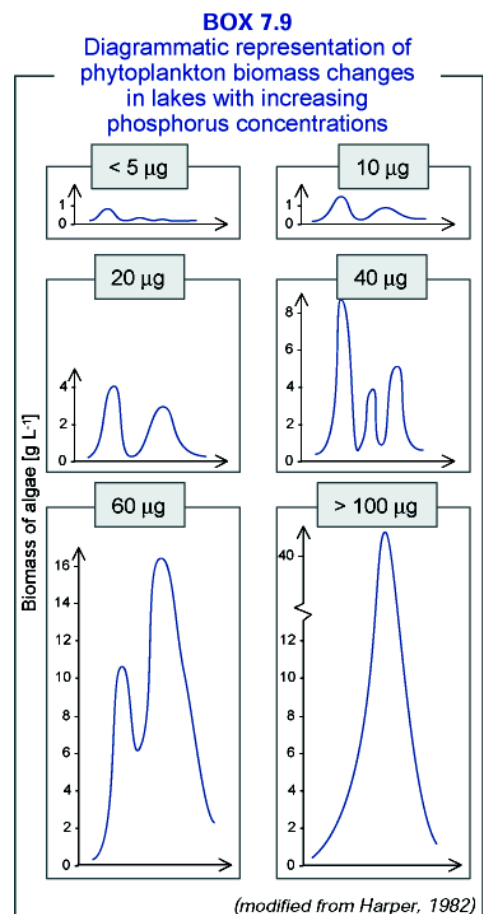

Fig. 7.3  
*Ceratium hirundinella*  
(photo: P. Znachor)



Knowledge about the hierarchy of factors that are responsible for phytoplankton succession and species domination in a reservoir is a valuable tool for effective management of these water resources.

**BOX 7.10**

Sequence of abiotic and biotic factors that regulate the occurrence and biomass of phytoplankton in the Sulejow Reservoir, Poland

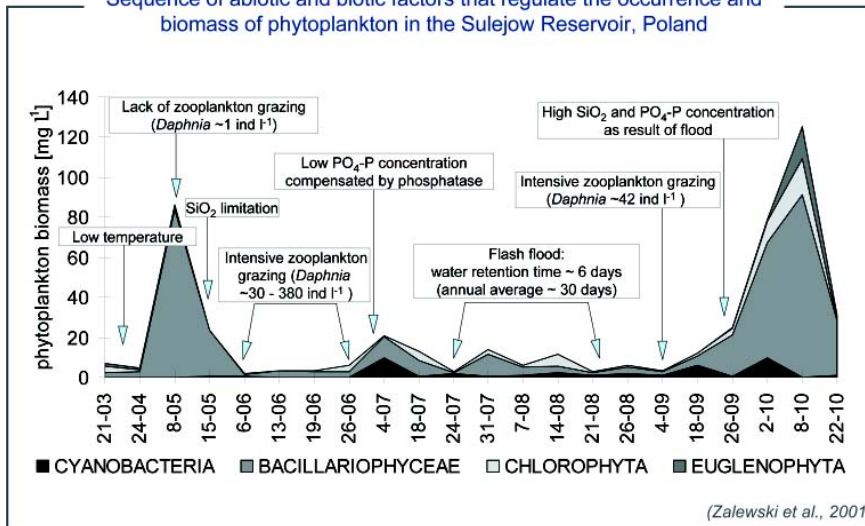

(Zalewski et al., 2001)

**BOX 7.11**

Methods of phytoplankton analysis

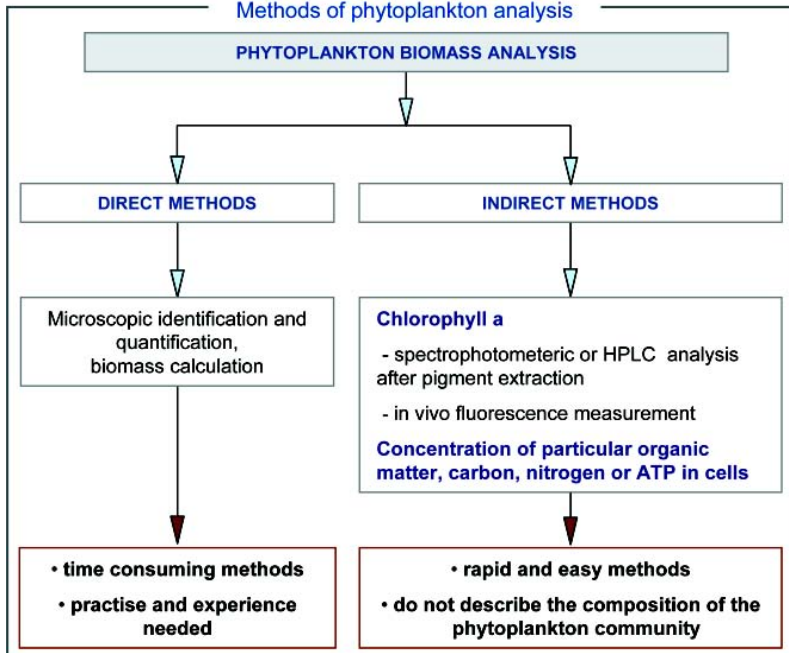

**HOW TO ANALYSE PHYTOPLANKTON**

Box 7.11 presents direct and indirect methods of phytoplankton analysis

**Number and location of stations**

The location of sampling stations may involve several points distributed horizontally over a water body. The number of sampling stations in a lake or reservoir depends on:

- ▶ **purpose of sampling:** for a preliminary survey it may be sufficient to collect samples at a single station in the centre of the lake.

▶ **morphometry of lake:**

- for lakes of regular shape, the station should be located in the centre of the lake;
- for lakes of irregular shape with several large bays, these should be sampled separately using at least 1 station; and
- for man-made reservoirs, samples should also be taken near the inflow and dam wall.



#### At which depths should we sample?

- ▶ in **shallow lakes** (maximum depth < 3 metres) collection of surface samples may be sufficient;
- ▶ in **deeper lakes** (maximum depth > 3 metres) it is recommended to take integrated vertical samples. According to standard procedures, samples should be collected from:
  - surface;
  - 1/3 of the depth of a lake;
  - 2/3 of the depth of a lake; and
  - 1 metre above the sediments.
- ▶ in **stratified lakes**, samples are taken from:
  - epilimnion (1 metre depth);
  - metalimnion (at the depth of the greatest temperature gradient); and
  - hypolimnion (1 metre above the sediments)

The sample volume should be adapted to the trophy of a lake:

- ▶ for eutrophic: 0.5 - 1 litres;
- ▶ for mesotrophic: 2 - 5 litres; and
- ▶ for oligotrophic: 5 - 10 litres.

#### How often do you have to sample?

- ▶ according to recommendations of many **standard** environmental monitoring programmes, a minimum of 12, or monthly, samples is recommended;
- ▶ for **advanced** qualitative or quantitative analyses of phytoplankton, the sampling frequency should be higher - weekly or biweekly during the open water season; and
- ▶ during **occurrences of harmful or noxious algae**, sampling should be done at least twice a week.

#### Field equipment

For phytoplankton investigations a tube sampler is recommended (Fig. 7.4). The sampler should be equipped with a cord with a depth measuring scale and a weight to close the closing device on top of the sampler. This type of sampler can be adapted for use at all depth intervals.

Plankton nets are not recommended for either qualitative or quantitative analyses of phytoplankton, since a large percentage of important algal species are much smaller than the mesh size of

even the finest mesh size. In an addition, fragile species can be broken and pass through nets.

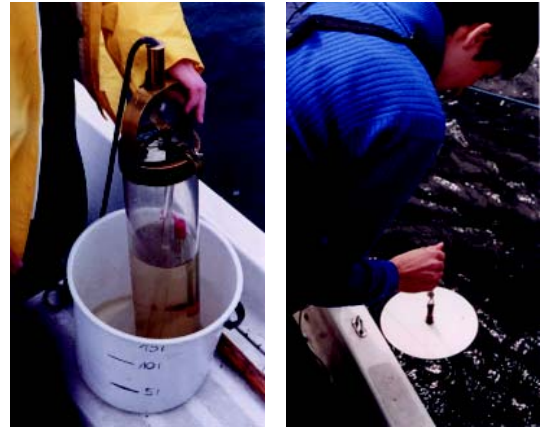

Fig. 7.4  
Tube sampler and Secchi disc  
(photo: M. Izydorczyk)

#### MICROSCOPIC ANALYSIS OF SAMPLES

The best tool for quantitative analysis of phytoplankton is a microscope. Counting procedures are similar whether a sedimentation chamber with an inverted microscope (Fig. 7.5) or slides or counting cells with regular microscope, are used. Cell volumes are calculated for each species from formulae for solid geometric shapes that most closely match the cell shape based on cell dimensions.



Fig. 7.5  
Utermöhl counting technique using a counting chamber and inverted microscope.  
(photo: Department of Applied Ecology)

## PIGMENT CONCENTRATIONS

- ▶ The most generally applicable measure of phytoplankton biomass is the quantification of **chlorophyll a**. However, the extraction procedure, although not expensive, is labour-intensive and time-consuming.
- ▶ The measurement of chlorophyll *in vivo* fluorescence, a very sensitive and non-destructive method, is a competitive technique (fig. 7.6). The fact that the method can provide information without time-consuming manual pre-treatment of water samples, has stimulated its application. The mapping of chlorophyll concentrations is the most common application of measured *in vivo* fluorescence. For quantitative determinations, *in vivo* data are compared with data on the concentration of extracted chlorophyll a. The production of chlorophyll a distribution maps, on the basis of fluorescence *in vivo* monitoring, permits the identification of hot spots in a reservoir (e.g., identification of areas where toxic algal blooms form. Box 7.12).

## INTERPRETATION OF RESULTS

On the basis of the phytoplankton and chlorophyll a concentration data, the trophic of a lake can be calculated. An example of lake classification is provided in the Table 7.4.



Fig. 7.6  
A flow-through fluorometer can be used for monitoring phytoplankton populations in reservoir (photo: M. Lzydorczyk)

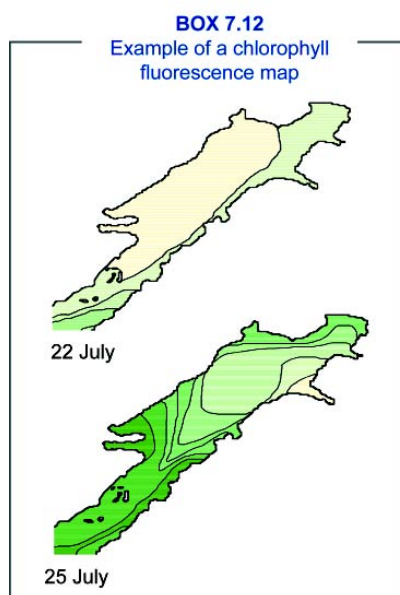

**TABLE 7.4**

Assessment of a lake or reservoir trophic on a basis of various parameters

PARAMETER	OLIGOTROPHIC	MESOTROPHIC	EUTROPIC	HYPERTROPIC
<b>Phytoplankton biomass</b> [mg L <sup>-1</sup> ]	<0,5	0,5 – 2,5	2,5 - 10	> 10
<b>Average chlorophyll a</b> [µg L <sup>-1</sup> ]	<2,5	2,5 - 8	8 - 25	> 25
<b>Chlorophyll a</b> (peak concentration) [µg L <sup>-1</sup> ]	4,2	16,1	42,6	> 500

### MAKE SURE TO CHECK THESE RESOURCES:

Guidelines: chapters 1, 2

<http://www.algaebase.org/default.html>

[http://www.nwhc.usgs.gov/pub\\_metadata/field\\_manual/chapter\\_36.pdf](http://www.nwhc.usgs.gov/pub_metadata/field_manual/chapter_36.pdf)

<http://www.whoi.edu/redtide/>

<http://wlapwww.gov.bc.ca/wat/wq/reference/cyanophytes.html>

<http://www.vcu.edu/cyanonews>

<http://www.health.gov.au/nhmrc/publications/pdf/eh22.pdf>

<http://www.vets.org.nz/publicat/vetscript/articles/articlemar03.pdf>

<http://www.pca.state.mn.us/water/clmp-toxicalgae.html>

## ■ 7.D. WHY ARE CYANOBACTERIAL BLOOMS HARMFUL

One of the most dangerous effects of eutrophication is the formation of phytoplankton blooms, with temporary domination of cyanobacteria during high temperatures and stable hydrological conditions (Codd, 2000). Cyanobacteria can produce different types of toxins, which can cause various health problems or even death if people or animals come into contact with them or ingest them (Resom et al., 1994; Carmichael, 2001; Chorus, 2001; Falconer 2001;).

The objective of this chapter is to present qualitative and quantitative assessment methods for cyanobacterial toxins.

### WHY ARE CYANOBACTERIAL BLOOMS HARMFUL?

Mass occurrences of cyanobacteria in water cause problems for producing drinking water and for recreational uses of the water.

- ▶ the exposure to cyanotoxins is expected to influence both morbidity (ill health) and mortality;
- ▶ toxic cyanobacterial blooms can cause health impairments such as skin irritations, allergic responses, mucosa blistering, paralysis of peripheral skeletal muscles and respiratory muscles, hay fever symptoms, diarrhoea, acute gastroenteritis, and liver and kidney damage;
- ▶ epidemiological evidence of increased rates of primary liver cancer and colorectal cancer in a specific population in China has been associated with the consumption of cyanobacterially contaminated drinking water (Yu, 1995; Zhou et al., 2000);
- ▶ cyanotoxins can accumulate in freshwater mussels, freshwater clams and fish, and transfer through the food chain.

### WHAT ARE THE STEPS IN A TOXICITY MONITORING PROGRAMME?

Expensive analytical techniques, modern equipment and high financial support for full chemical analysis of the quantity and quality of cyanobacterial toxins are usually required. A cyanobacterial extract may contain a variety of chemical substances like acids, peptides or pigments, which may be unknown. Their potential effects can only



Fig. 7.7  
A *Microcystis* bloom near the drinking water intake in Sulejow Reservoir, Poland, September 1999 (photo: M. Tarczyska)

be detected by toxicological testing in conjunction with chemical toxin analysis. In many cases and, more importantly, is an estimation of the toxic effect of complete mixtures, whether they are known or unknown, than detection of selected, individual contaminants.

The first step of investigation should involve bioassays using different organisms (biotest) and enzymes (biochemical methods) for screening the toxicity of complex mixtures. Further, the chemical analysis to determine the quality, quantity and original source of harmful individual substances should be applied (Box 7.13).

*The World Health Organization (WHO) recommended 1 microgram per litre as a safety guideline value for the maximum acceptable level of microcystin-LR or its equivalents in drinking water due to the epidemiological character of cyanobacterial toxins (WHO, 1998).*

### HOW TO DETECT SPECIFIC TOXINS

#### Biotests (biological methods)

Biotests with different organisms (bioindicators) can provide both estimations of complete mixture toxicity, without determination of the potential effects of individual contaminants (Appendix 6). Synergistic or antagonistic effects between complex mixtures can also be analysed.

In previous investigations, a mouse was the most popular organism that was used to biotest in cyanobacterial research. This kind of bioassay involves oral consumption or intraperitoneal injection

**TABLE 7.5**  
Cyanobacterial toxins and their producers

TOXIN TYPES	CYANOBACTERIAL GENERA
<b>Hepatotoxins</b> Microcystin Nodularin	<i>Anabaena</i> , <i>Anabaenopsis</i> , <i>Aphanocapsa</i> , <i>Hapalosiphon</i> , <i>Microcystis</i> , <i>Nostoc</i> , <i>Oscillatoria/Planktothrix</i> <i>Nodularia</i>
<b>Neurotoxins</b> Antoxin-a, Homoanatoxin-a Anatoxin-a(s) Saxitoxin	<i>Anabaena</i> , <i>Aphanizomenon</i> , <i>Cylindrospermum</i> , <i>Microcystis</i> , <i>Oscillatoria/Planktothrix</i> , <i>Phormidium</i> <i>Anabaena</i> , <i>Oscillatoria/Planktothrix</i> , <i>Anabaena</i> , <i>Aphanizomenon</i> , <i>Cylindrospermopsis</i> , <i>Lyngbya</i>
<b>Cytotoxin</b> Cylindrospermopsin	<i>Aphanizomenon</i> , <i>Cylindrospermopsis</i> , <i>Umezakia</i>
<b>Dermatotoxins</b> Debromoaplysiatoxin Lyngbyatoxin Aplysiatoxin	<i>Lyngbya</i> <i>Lyngbya</i> <i>Lyngbya</i> , <i>Oscillatoria</i> , <i>Schizothrix</i>
<b>Lipopolysaccharides (LPS)</b>	Many species of cyanobacteria

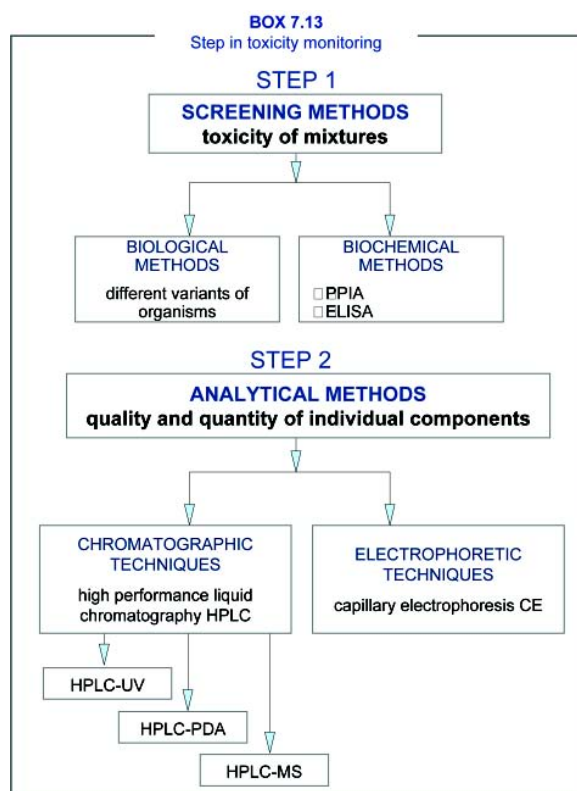

of a cyanobacterial extract into the mouse and determination of the dose that kills (lethal dose, LD) 50% of mice used in an experiment (LD<sub>50</sub>). Moreover, biotests with mice provide a characterization of cyanobacterial toxins, which are classified into **hepatotoxins, neurotoxins and toxins with protracted effects**.

Present research needs more ethical, less time-consuming and more cost-effective tests to minimize the use of mammals for experimental testing. Therefore, bioassays for cyanobacterial toxicity require further development of biotests with simple organisms or plants, such as **bacteria, invertebrates, protozoans or plants**.

### What conditions have to be met by the organisms used as bioindicators?

For organisms to be widely used as bioindicators a number of conditions have to be met (Persoone & Gillett, 1990; Suess, 1982).

- ▶ have to be available over the whole year;
- ▶ should be genetically uniform;
- ▶ have to be healthy and in good condition at the time of testing;
- ▶ test reactions have to be evident and repeatable, easy to observe and interpret and have a statistical background;
- ▶ in environmental analysis the organisms should be typical of a specific country or region; and
- ▶ in heavy contamination conditions they should be sensitive to a broad spectrum of toxic substances.

The sensitivity of these tests with microorganisms or plants should correlate with the sensitivity of vertebrates.

Examples of invertebrates used for testing include *Drosophila melanogaster* and different species of mosquitoes, such as *Culex pipiens*, *Aedes aegypti*, and *Culiseta longiareolata*. Despite the high sensitivity of these organisms, they are not often used because the methods need continuous cultures of test organisms.

### Bacterial tests

Bacterial tests as a cost-effective and rapid method are a useful tool for toxicity assessment. Fluorescent bacteria, *Vibrio fischeri*, have been proposed as suitable microorganisms for determining cyanobacterial toxicity (Appendix 6). Bioluminescent tests, such as Microtox, have shown that *Vibrio fischeri* can be used to analyze the toxicity of purified cyanobacterial extracts. ToxAlert, a second toxicity test kit (or toxikit) with *Vibrio fischeri*, has given positive signals in determining the toxicity of crude and purified cyanobacterial extracts. The other effective bacterial test for determining cyanobacterial toxicity is ToxiChromoPad that uses *Escherichia coli* as the test organism (Appendix 6).

### Plant tests

The toxicity of cyanobacterial blooms can be determined using water plants, e.g., *Spirodela oligorrhiza* or *Lemna minor* L. Plants are easier to handle than animals and have proved to be useful in monitoring contamination of water by heavy metals and algal toxins. Cyanobacterial hepatotoxins inhibit the growth of *S. oligorrhiza* by reducing the number of fronds and decreasing chlorophyll (a + b) concentrations.

There is a need to develop new, and evaluate less well known, biotests utilizing higher plants, particularly seeds and seedlings of plants and water macrophytes.

### Advantages of water plants (macrophytes) as bioindicators of water pollution

Several authors (Landolt & Kandeler, 1986; Lewis, 1995; Swanson et al., 1991; Wang, 1989) have noted the advantages of using macrophytes as bioindicators of water pollution:

- ▶ macrophytes are more sensitive to contaminants than algae;
- ▶ they are very sensitive to pesticides;
- ▶ they have high reproductive rates (1-4 days), small size and are easier to propagate than other plants;
- ▶ water plants (*Lemnaceae*) are more sensitive than invertebrates that were usually used until now;
- ▶ easy to use in laboratory conditions; and
- ▶ results of laboratory evaluations are comparable to tests conducted in natural conditions.

### Advantages of seeds bioindicators of water pollution

The use of seeds as bioindicators produce less problems than fishes, algae and crustacea and their advantages include:

- ▶ seeds, typical of a specific climate or environment, are easily available in each geographic location and there are no problems with their transport, storage and preparation for tests;
- ▶ seeds can be stored for many years without changes in vigour and physiological condition;

- ▶ the physiology and morphology of seeds is well known, which makes their use in bioindicator tests easier;
- ▶ seeds of higher plants and their seedlings are sensitive to a broad range of environmental contaminants;
- ▶ due to the small dimensions of seeds and their uniformity and low weight, small water samples can be tested;
- ▶ test reactions are repeatable and easy to observe, measure and apply;
- ▶ for seed tests no expensive equipment is necessary nor is filtration of water samples; and
- ▶ seed tests are easy to conduct and are more humanitarian than those on, e.g., fishes.

It is believed that biotests, which make use of seeds and macrophytes, thanks to their low cost, easy procedures and permanent availability of biological material, can play an important role in the bioindication of water pollution, including bioindication of toxic cyanobacterial blooms. Thanks to the high sensitivity of water plants from the Lemnaceae family, information on water toxicity can be obtained within 24 hours.

### Toxikits

Quick tests should become an integral part of water quality assessment. To ensure repeatability of results uniform conditions of testing, as well as rearing procedures for test organisms, are essential. In recent years, complete kits for toxicity tests have become available commercially (so-called Toxikits). They include all materials, along with test organisms, necessary for conducting rapid and accurate tests.

Such kits eliminate the problems with the delivery and culturing of enough organisms from the same source in similar conditions. Moreover, organisms in each toxikit have the same sensitivity to toxins. Proper selection of organisms and exposure times enables results to be obtained within a few minutes or hours. The materials and reagents contained in the kit reduce test preparation time and eliminate errors that may occur during reagent preparation. Toxikits guarantee standardization and validation of bioassays. Unfortunately, Toxikits are very expensive and require a high number of replications.

### Biochemical methods

**Protein phosphatase inhibition assay (PPIA)** and **enzyme-linked immunosorbent assay (ELISA)** are rapid (2 hour treatment times) and sensitive screening methods for detection of hepatotoxins and determination of their toxicity (Appendix: 7). Both methods enable detection of very low doses of microcystins, even directly from drinking water supplies below  $1 \mu\text{g L}^{-1}$  microcystin-LR.

**A colourimetric protein phosphatase inhibition assay with enzyme protein phosphatase 1 (PP1) and the substrate p-nitrophenylphosphate (p-NPP)** is a useful tool for determining the toxicity of microcystins and nodularins contained in cyanobacterial samples.

However, a protein phosphatase inhibition assay, using  $^{32}\text{P}$ -radiolabelled phosphorylase as a substrate, has proved to be more sensitive for detecting and determining the toxicity of hepatotoxins than the colourimetric protein phosphatase assay. This radiolabelled assay can use both protein phosphatase 1 and 2A (PP1 and PP2). Unfortunately, equipment requirements for the radiolabelled protein phosphatase assay (e.g., a liquid scintillation counter) are higher than for the colourimetric assay.

Enzyme-linked immunosorbent assay, such as the protein phosphatase inhibition assay, is useful for initial toxicity screening. Commercially the ELISA kit (EnviroGard, EnviroLogix) is available for quantifying microcystins. The estimation of microcystin concentrations by this colourimetric method requires specific antibodies, which are fixed to the walls of tubes or wells in a microplate.

Both the PPIA and ELISA colourimetric methods need a plate reader to measure the results of both the p-nitrophenyl (p-NP) (PPIA) and microcystin-enzyme conjugate (ELISA), assays.

### Analytical methods (chemical analysis)

Analytical methods are based on the physical and chemical properties of cyanotoxins, such as molecular weight, chromophores and reactivation products due to the functional groups in the molecules. A summary of chromatographic methods usually used for the detection of cyanotoxins is given in Appendix 8.

The most common analytical procedure for the determination of microcystins (intracellular and extracellular) is **high performance liquid chromatography (HPLC)**, which provides identification of microcystins using their characteristic spectrum at an absorption of 238 nm. The HPLC method can be used for monitoring toxic cyanobacterial blooms in water.

High performance liquid chromatography combined with **UV detection** has been used extensively for the detection of microcystins. But, because this method relies on retention time for identification, microcystin standards are required. Detection by UV can be made more specific by using a photodiode array (PDA) detector, but it has very limited ability to identify individual microcystins because almost all microcystins have a similar UV spectrum (Box 7.14).

To further confirm and identify cyanotoxins analytical methods coupled with **mass spectrometry** are used. For example, liquid chromatography coupled with mass spectrometry (LC-MS) is a very promising method for the simultaneous separation and identification of microcystins in mixtures. Identification of the microcystin characteristic ion at  $m/z$  135, derived from Adda (a unique amino acid, which serves as the key structural component for the biological activities of microcystins), has proven to be useful for discriminating microcystins from other types of compounds.

Also other similar techniques such as **capillary electrophoresis (CE)** and related techniques must also be considered for the separation and quantification of peptide hepatotoxins. CE coupled with mass spectrometry gives a low limit of detection and increased sensitivity method for determining microcystins. However, due to poor result replication this method requires further evaluation.

High performance liquid chromatography, as well as capillary electrophoresis, are the only analytical

techniques that can separate and identify cyanotoxins simultaneously (Meriluoto et al., 1998). Analytical techniques based on either HPLC or LC-MS can also be used for determining saxitoxins, anatoxins or cylindrospermopsin in water.

A physical and chemical screening method that is based on the detection of 2-methyl-3-methoxy-4-phenylbutyric acid (MMPB) as an oxidation product of microcystins, has been reported. Gas chromatography (GC) coupled with mass spectrometry, or HPLC coupled with fluorescence detection, are used to identify microcystin oxidation products.

Despite the number of techniques used for identification of microcystins, only high performance liquid chromatography finds application in qualitative and quantitative determinations of cyanotoxins in water and cyanobacterial cells with regards to simplicity, high sensitivity, selectivity and, almost as importantly, high precision. Unfortunately, in situations when standards are commercially unavailable for the majority of toxins the HPLC method cannot be used.

**Biological methods** of toxin detection (e.g., microbiotest with bacteria and invertebrates) are useful as an initial toxicity screening method for cyanobacterial detection. However, because of low sensitivity and high detection limits for cyanotoxins, they cannot replace biochemical methods (e.g., PPIA and ELISA) or chemical methods (e.g., HPLC).

For the detection of very low concentrations of hepatotoxins, the **PPIA** or **ELISA** test should be used. For qualitative and quantitative chemical analysis of cyanobacterial toxins, HPLC is needed. **Because of our still incomplete knowledge about cyanobacterial toxins and their toxicity, biological, biochemical and chemical methods should be applied jointly.**

**BOX 7.14**

Chromatogram of microcystins (MC) standard separations and water sample with photodiode array detection and characteristic UV spectrum of microcystins with absorption maximum at 238 nm. Peak identification: MC-RR, MC-YR, MC-LR and unknown peak with typical microcystin spectrum.

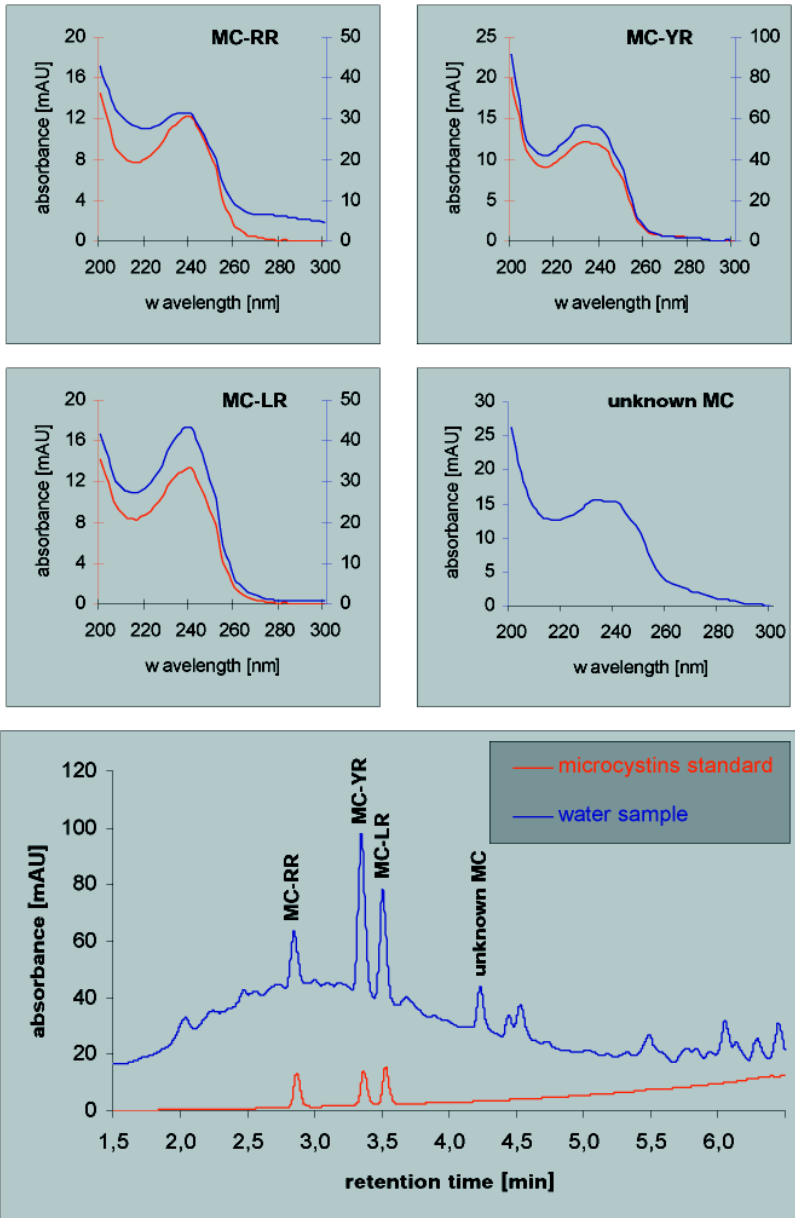

**MAKE SURE TO CHECK THESE RESOURCES:**

Guidelines: chapters 8

<http://www-cyanosite.bio.purdue.edu/>

<http://www.cyanobacteria-platform.com/main.html>

<http://www.murraybluegreenalgae.com/>



## ■ 7.E. ASSESSMENT OF ZOOPLANKTON COMMUNITIES

Zooplankton are an important link between phytoplankton primary production and consumers at the higher levels of the trophic cascade (secondary producers). They may impact the pathways of energy flow and matter circulation in freshwater ecosystems.

This chapter presents methods for analysing zooplankton communities in fresh waters. It will also introduce methods for estimating ecosystem status and the ecological state of a lake or reservoir. These take into consideration abiotic and biotic parameters that seasonally influence zooplankton communities.

### WHY SHOULD WE INVESTIGATE ZOOPLANKTON COMMUNITIES?

Zooplankton are an important link in the **trophic chain**. They are both omnivores and predators, thus occupying not only the second, but also the third, levels in the grazing food web. Some zooplankton representatives, like ciliates and some Cladocera (ex. *Bosmina* sp.), may also control the microbial food web („microbial loop”) as top predators (Lenz, 1992).

The most spectacular role, from the point of view of **water quality** in lakes and reservoirs, is played by larger zooplankters (metazooplankton), which may control phytoplankton blooms. Therefore, understanding zooplankton structure as well as the parameters influencing their community, may be used for manipulation of ecosystem structure in order to allocate nutrients from available to unavailable pools

An additional role that is not often taken into account in cascading interaction studies, is the activity of **predatory zooplankton** such as *Asplanchna* sp. (Rotatoria), *Bythotrephes* sp. or *Leptodora kindtii* (Cladocera). It has been proven that these species have intensive predation rates and can significantly **reduce populations of filtering Cladocera** when the density of planktivorous fish is low (Lunte & Luecke, 1990; Wojtal et al., 1999). Invertebrate predators are very effective and can significantly influence filtering zooplankton populations.



Fig. 7.8  
*Daphnia longispina*  
(photo: A. Wojtal)

### HOW DO ZOOPLANKTON INFLUENCE WATER QUALITY?

The concept of „biomanipulation” states that zooplankton are the key element in the functioning of most lake and reservoir ecosystems in temperate regions. Whether this is also true for tropical reservoir and lake ecosystems is still unresolved. This is connected with the fact that zooplankton of tropical water bodies are generally of small size and less abundant than in temperate systems. Moreover, to evaluate the functional role of microcrustacean zooplankton in tropical aquatic food webs, it is essential to quantify the dynamics of zooplankton production as microcrustaceans in tropical systems reproduce continuously (Amarsinghe et al., 1997). Our present knowledge recognizes the complex role of zooplankton in aquatic ecosystem trophic structures and their role in exercising top-down control through grazing or predation.

### WHAT PARAMETERS INFLUENCE ZOOPLANKTON COMMUNITY STRUCTURE AND DYNAMICS?

Zooplankton community structure and dynamics are regulated by many biotic factors. The most important are:

- ▶ abundance and quality of food;
- ▶ grazing pressure that releases several defence mechanisms in phytoplankton; and
- ▶ fish community structure.

Zooplankton distribution depends mainly on:

- ▶ water depth;
- ▶ trophic status; and
- ▶ water temperature.

An interesting feature of zooplankton is their **daily horizontal and vertical migrations**, which occur at dusk and dawn. Vertical migrations, even up to several hundred metres (*Calanus* sp.), are characteristic of deep lakes, while in shallow lakes, horizontal migration is observed.

Species diversity is generally governed by the **temperature regime**. The highest diversity is found in tropical and subtropical regions and the lowest in extreme environments, such as polar zones and brackish water areas. Temperature is also the most important external factor governing the growth and metabolic rates of zooplankton.

Another significant factor is **food availability**, which varies with season. Thus, the majority of organisms have adapted their life cycle in such a way that they encounter optimal conditions during their reproductive period. Under optimal food conditions, the highest turnover rate is observed in small organisms in the tropics and the lowest in large organisms in polar regions (Harris et al., 2000).

Tropical lakes differ in at least two fundamental properties from temperate lakes: high annual irradiance, and low daily and annual variations in irradiance. These result in a limited number of effects, of which high water temperature, low variation in water temperature and high primary production, are the most important to secondary production (Amarasinghe et al., 1997).

#### THE ROLE OF HYDROLOGICAL PARAMETERS AND NUTRIENT AVAILABILITY

Important factors regulating the intensity of primary production and, thus food availability for zooplankton, are high phosphorus loads and low N:P ratios. *Daphnia* spp. are known to have much lower C:P (around 80:1 to 100:1) and N:P ratios in their stoichiometry than most other freshwater zooplankton studied so far (Andersen & Hessen, 1991). The high demand for P has two consequences: cladocerans have to minimize P-losses via excretion when algal food is short in P (Elser & Urabe, 1999). This leads to an enhancement of P-limitation of algae. Second, cladocerans might become P-limited if food is abundant but poor in P (Sommer, 1992). The threshold for P-limitation

for *Daphnia* seems to be at a food C:P ratio of approx. 300:1 (Sommer & Stibor, 2002). Copepods have a much lower tissue P-content and, consequently, higher C:P and N:P ratios than cladocerans (Andersen & Hessen, 1991).

External nutrient loads to reservoirs depend on catchment geomorphology and use, climatic conditions and consequent hydrological factors of the reservoir and its tributaries. The pattern of tributary discharges also alter abiotic conditions in a reservoir, such as water retention time, water transparency and water column stability. The supply of high matter loads to reservoirs is also important for the development of small filtrator (e.g., *Bosmina* sp.) populations and may regulate the microbial loop.

#### METHODS OF ZOOPLANKTON COMMUNITY ASSESSMENT

##### Number and location of stations

The number and location of stations depends on the degree of diversity of a study site.

Stations should be located in sites with different characteristics, which includes hydraulic parameters, water inflow, bottom structure (also presence of submerged macrophytes), depth, physical-chemical factors, predatory pressures, quantity and quality of food (phytoplankton, bacterioplankton, picoplankton), and anthropogenic pressures. For advanced ecological analysis of a water body status, samples should be taken together with water samples for chemistry and phytoplankton biomass assessment (see chapter 7.C).

##### Sampling methodology

In order to collect zooplankton the following samplers may be used:

- ▶ **water bottle samplers**, for taking discrete samples or relatively small volumes of water (a few litres);
- ▶ **pumping systems** that sample intermediate volumes of water (tens of litres to tens of cubic metres);
- ▶ **nets** of many different shapes and sizes that are towed vertically, horizontally or obliquely.

ely and sample much larger volumes of water (tens to thousands of cubic metres), apply mainly to oceanography studies.

A detailed description of plankton samplers was given by, e.g., Harris et al., (2000).

The type of preservative used to fix zooplankton samples will depend on the purpose for which the samples were taken. In general, zooplankton are preserved in 4% Lugol's solution or in 4% formaldehyde. The various techniques for zooplankton fixation and preservation are given in „Zooplankton fixation and preservation“ edited by Steedman (1976).

#### Time and frequency of sampling

For advanced analysis, zooplankton should be sampled weekly or bimonthly starting at the beginning of the summer season (April-May in temperate regions) up to October, with three replicates for each sampling date.

However, adequate assessment of zooplankton communities can never be conducted on the basis of a single sampling because of the high seasonal fluctuations of zooplankton density and community structure. Therefore, interpretations of the results will very much depend on the degree of understanding of these processes.

### UNDERSTANDING SEASONAL ZOOPLANKTON FLUCTUATIONS FOR INTERPRETATION OF RESULTS

A scheme of seasonal fluctuations of phyto- and zooplankton is represented in the PEG Model (Plankton Ecology Group), which was constructed on the basis of the results from 24 eutrophic lakes. In the case of oligotrophic lakes, fluctuations proceed at a slower rate and insom ecosystems do not include all stages (e.g., clear water phase) - Box 7.14.

According to the PEG Model this is a typical specific sequence of plankton succession and includes the following stages (Sommer et al., 1986; Sommer & Stibor, 2002) (Box 7.15):

- ▶ **biomass accumulation** during spring -the first phytoplankton biomass maximum due to high

biomass of edible phytoplankton (rarely appear in oligotrophic lakes).

- ▶ phytoplankton spring bloom is followed by a **clear water phase**, with low phytoplankton biomass caused by zooplankton grazing.
- ▶ **decrease of metabolic rate** (decreasing of P:B relationship) of phytoplankton. This process is discontinued during the clear water phase;
- ▶ **decrease of zooplankton density is observed** because of enhanced competition resulting from food limitation;
- ▶ in summer strong **pressure of invertebrate and vertebrate (fish)** predators may be observed; and
- ▶ **biomass decrease of large filterers** (*Daphnia* sp.) may appear in summer because of food limitation. High biomass of inedible algae (e.g., Cyanobacteria).

*Clear water phases usually do not occur during summer when there is an abundance of less edible algae that can compensate by growth for the losses of more edible algae. Thus, the top-down impact of zooplankton during summer will mainly be reflected by the taxonomic and size class composition of phytoplankton.*

- ▶ **switch from phytovorous to detritovorous modes of feeding.** Inedible algae are partly exploited by parasites and detritovorous animals.

### INTERPRETATION OF RESULTS

The schemes presented in Box 7.16 should be helpful in interpretation of your results. It shows the variability of processes in eutrophic lakes where they are mainly dependent on winter temperature, as well as in such systems where processes depend on biotic interactions (mainly predatory pressure). If you find similar results, you should follow the arrows to identify the processes regulating zooplankton communities in your ecosystem.

**BOX 7.15**

**Comparison of zooplankton dynamics in eutrophic and oligotrophic ecosystems**

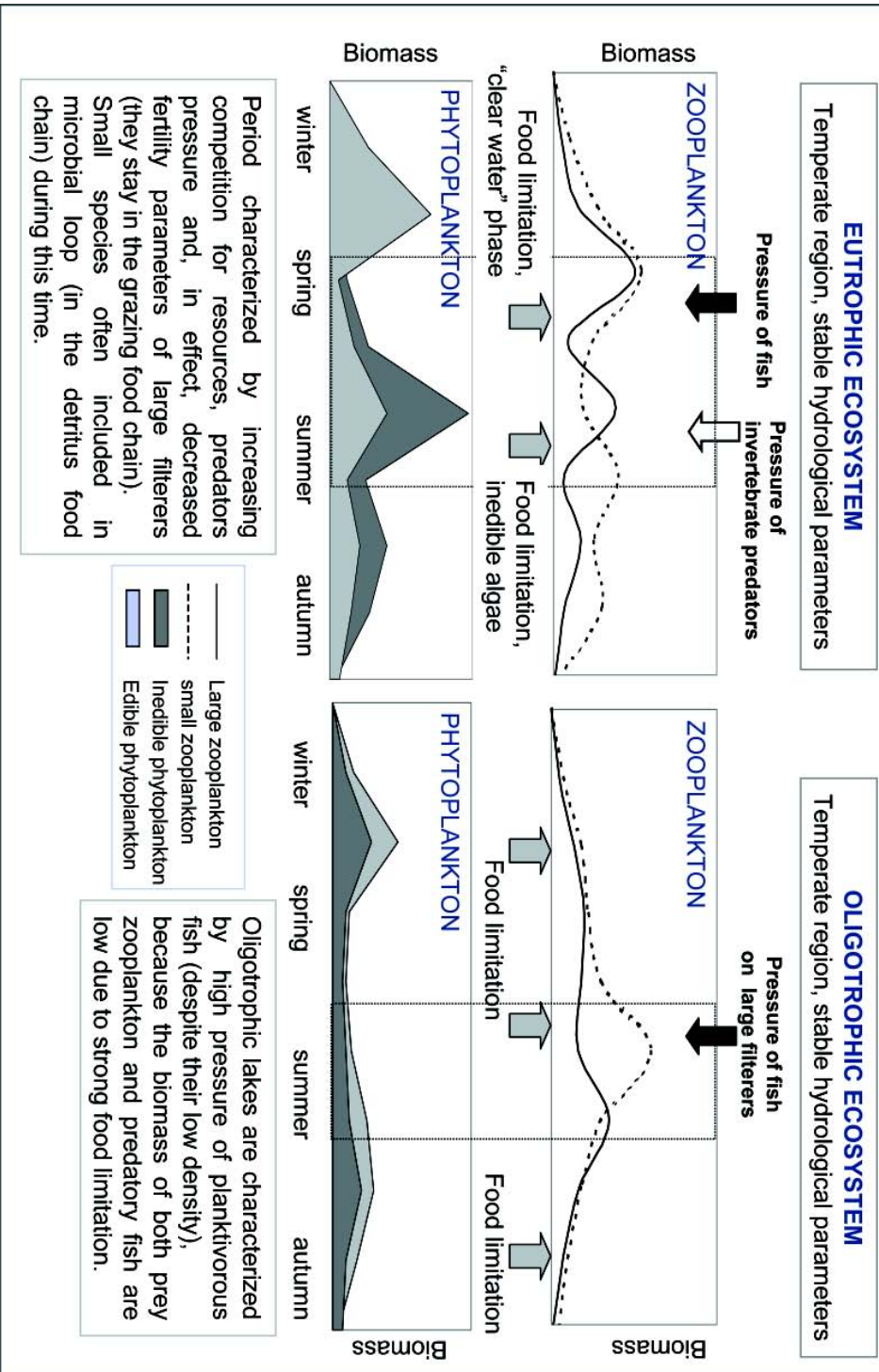

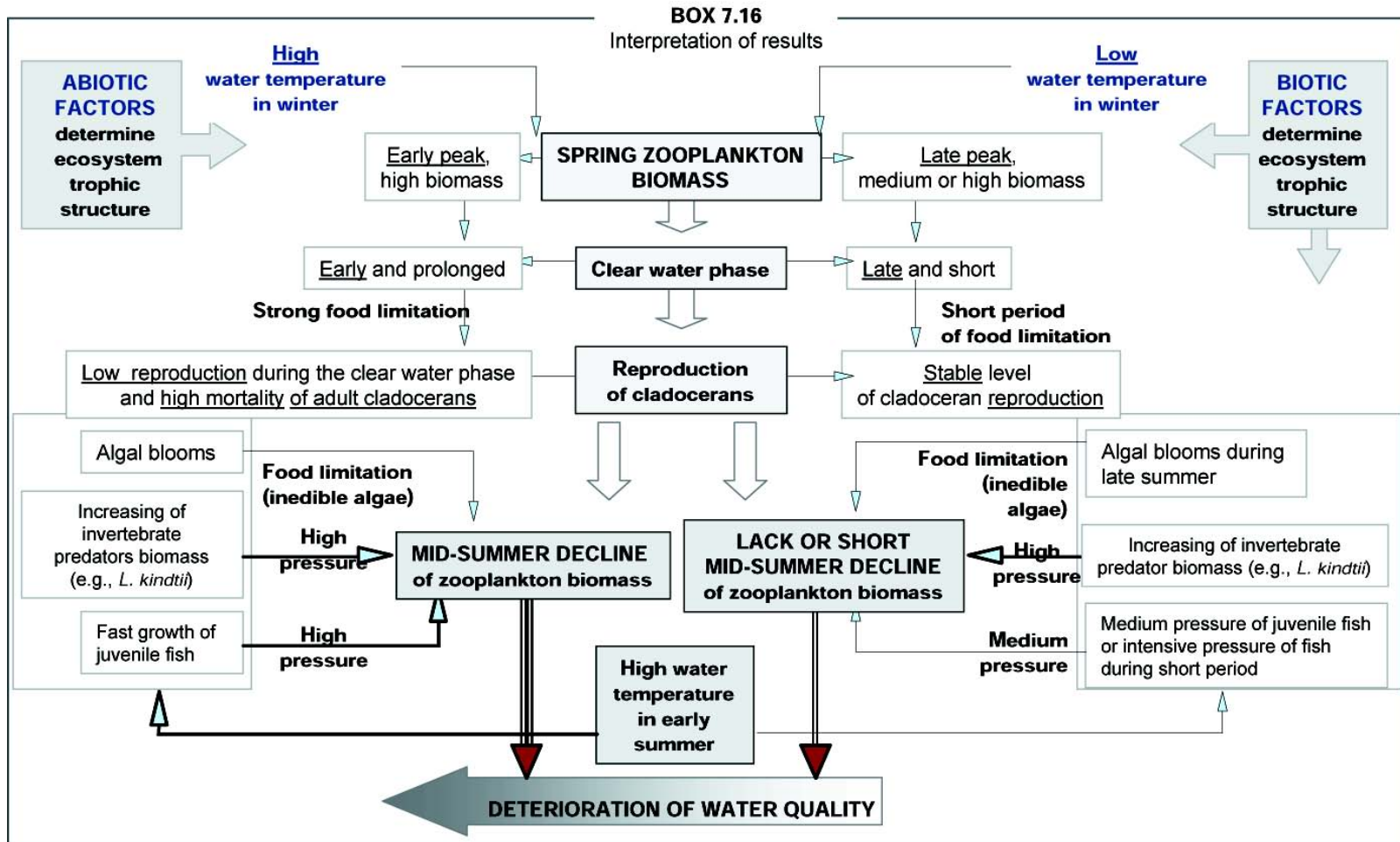

## 7.F. ASSESSMENT OF FISH COMMUNITIES

The variety of fish responses to changing environmental conditions allows us to assess the state of a freshwater ecosystem on the basis of its fish community structure and abundance of specific fish species. Understanding the fish community structure is essential for decision-making in the process of applying water quality control methods based on ecohydrological relationships, e.g., bio-manipulation. The objective of this chapter is to present methods for fish community assessment.

### WHAT SAMPLING METHODS ARE USED FOR FISH COMMUNITY STRUCTURE ASSESSMENT?

To achieve a precise picture of fish assemblages, application of various sampling methods adjusted to the characteristics of a given water body, e.g., expected fish species and their age structure, is necessary. The most frequently used quantitative sampling methods for fish communities are:

- ▶ **gill netting** - passive capture used for fishing in a pelagic zone. Gill nets have a rectangular shape and are usually 50 m long and up to 10 m in width. They are positioned vertically at different depths and regulated by the amount of buoys fixed to the top edge of the net and the weights on the bottom line. To cover all fish age classes, standard gill nets consisting of many sections of different mesh sizes (usually from 5 to 85 millimetres) are used;
- ▶ **trawling** or **push netting** - active techniques used for fishing in the pelagic zone (Fig. 7.10). Using these methods one can collect fish from a selected depth. In the case of trawling, the net is pulled behind the boat, while a push net is fixed to the front of a boat. Depending on the power of the boat engine, the length of the net and the size of its opening may differ greatly to enable optimal speed of sampling; and
- ▶ **electrofishing** - active capture usually used for collecting both adult and juvenile fish in a vegetated littoral zone. A pulsed D.C. current of 230 V and 3-4 A and an anode equipped with a dip net, are usually used for fish sampling.



Fig. 7.9

Perch

(photo: [www.first-nature.com](http://www.first-nature.com))



Fig. 7.10

Push netting

(photo: A. Wojtal)

- ▶ **beach seining** - active netting used for collecting juvenile fish in a littoral zone (Fig. 7.11). A heavy chain should be fitted to the bottom line of the net to prevent lifting while passing over obstacles. The top edge of the net should float preventing fish escaping over it. While sampling, the net is drawn into the water to form a closed semicircular area. Then, the net is drawn back up, out of the water and on to the bank; and
- ▶ **angler interviews** - this method depends on direct counting and identification of fish caught by anglers or/and using data from questionnaires completed by anglers. As angling

is often focused on predatory fish, it is recommended to obtain more complete qualitative data on fish communities by checking what prey-fish species are present in the stomach contents of examined predators.

- ▶ in the case of trawling and push netting it is the number of fish captured per cubic metre of net; and
- ▶ in the case of beach seining it is the number of fish captured per 100 square metres



Fig. 7.11  
Beach seining  
(photo: A. Wojtal)

#### WHAT ARE THE GENERAL RULES FOR FISH SAMPLING?

In order to obtain qualitative data, the following general rules should always be applied to data collection in most lakes and reservoirs:

- ▶ sampling should be done at stations **representing the main habitat types** in the water body. It is important to collect fish with different habitat requirements;
- ▶ it is recommended to carry out sampling both during the **day and at night** in order to take into account possible data variance due to daily fish migrations; and
- ▶ in order to obtain a reliable dataset, sampling should be repeated using the same procedure in different seasons of a year, to take into account seasonal fish migrations.

#### DATA CALCULATIONS

To obtain comparable data, fish catches should be expressed as CPUE (**catch per unit effort**):

- ▶ in the case of gill nets it is the number of fish captured during one hour by one square metre of net;
- ▶ in the case of electrofishing it is the number of fish stunned by an anode during a given period of time;

#### WHAT IS MARK-RECAPTURE?

A frequently used method for estimating the abundance of a fish population is mark-recapture. This method is based on collecting fish, marking them, and returning them to an ecosystem. The fish are captured again after a few days and the number of marked specimens is counted. Estimation of total fish number (N) is based on the assumption that the proportion of marked fish in this second sample is the same as the proportion of all marked fish in the total population:

$$N = n_1 n_2 / m$$

Where:

- $n_1$  - the number of fish collected and marked in the first catch;
- $n_2$  - the number of fish collected in the second catch; and
- $m$  - the number of marked fish found in the second catch.

This method should be used with caution, however, as it requires restrictive assumptions about the population and the marking process:

- ▶ marks should be durable and well recognised;
- ▶ all fish should be sampled at random;

- ▶ marked fish should have the same probability of dying, emigrating and being recaptured as the unmarked ones; and
- ▶ during the period of investigation, population abundance should not change.

#### WHAT ARE HYDROACOUSTICS?

The most sophisticated and accurate tool for estimating fish density and biomass is hydroacoustics (Fig. 7.12). Fish density is calculated as the ratio between the number of targeted fish and the volume of sound-penetrating water. The best results are achieved when fish are randomly distributed and have a low density. Compared with traditional methods of fish community assessment, the use of hydroacoustics has several advantages:

- ▶ covers **large areas** within a short time;
- ▶ provides huge amount of **data**;
- ▶ makes possible **fast computer processing** of data; and
- ▶ is **cost-effective** (excluding high initial costs of equipment).

The main weakness of this techniques is lack of species identification and difficulties in acquiring proper data from shallow waters.



Fig. 7.12  
Simrad EY 500 portable scientific sounder system  
Simrad Company

#### MAKE SURE TO CHECK THESE RESOURCES:

Guidelines: chapters 8



## ■ 8.A. WATER CHEMISTRY

Estuaries and adjacent coastal areas are very different in terms of water circulation patterns, morphology, anthropogenic pressures, etc. Thus, general sampling rules are difficult to recommend. In this chapter we refer to the ecological relevance of some chemical parameters, the methods or equipment that can be used, and where and when to collect samples. The reader must critically evaluate the best and most accurate sampling protocols according to his/her sampling site characteristics or study aims.

### WHAT ARE THE KEY PARAMETERS TO BE MEASURED IN COASTAL AREAS?

In estuaries and coastal areas, salinity, dissolved oxygen, pH, turbidity, nutrients and chlorophyll are usually the key parameters responsible for maintenance of adequate conditions for reproduction, growth and survival of species.

Measuring water parameters in estuaries and coastal areas is different from sampling in fresh water because salinity interferes with measurements. In fact, salinity reduces oxygen solubility and increases pH buffering effect. Moreover, turbidity, chlorophyll and nutrients concentrations are lower in saline waters, which requires detection limits to be changed.

#### Salinity

Salinity is a typical parameter measured in order to characterize estuaries and coastal zones. For this reason, particular attention will be placed on this parameter.

Salinity is the concentration of all the salts dissolved in water. The salt in the ocean is mostly made up of the elements sodium (Na) and chlorine (Cl), accounting for 85.7% of the dissolved salt. Together with the other major components of seawater, magnesium (Mg), calcium (Ca), potassium (K) and sulphate (SO<sub>4</sub>), they represent 99.4% of the salt in the ocean.

Since water conducts electricity better with increasing salt concentrations, the conductivity of water reflects its salt content (Box 8.1) Salinity can also be measured with a hand held refractometer, but with a lower precision level than with a conductivity metre. When a salinity calculation

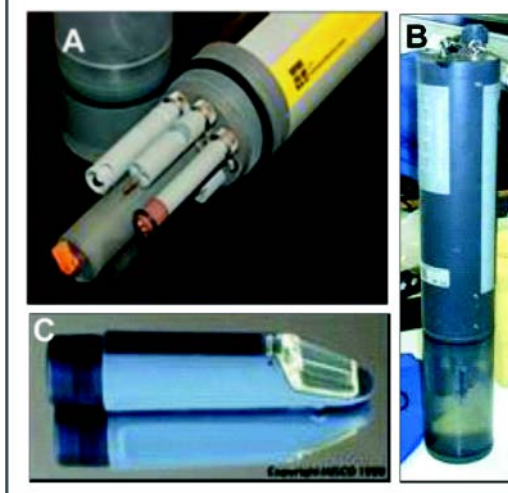

Fig. 8.1  
Water Sampling in coastal areas (photo: L. Chicharo)

algorithm is used, results are shown in salinity units and the apparatus is considered to be a salinometer.

#### BOX 8.1

Sensors used on CTD (Conductivity, Temperature, Depth - A), measuring device - B, Refractometre - C



Salinity is usually expressed in practical salinity units (PSU), but also in ppt (parts per trillion) and ‰. More recently salinity is considered without units. The average ocean salinity is 35.

According to the Venice system, Box (8.2), different areas can be delineated in an estuary based on salinity values.

Salinity variations depend on the mixture of fresh water and ocean water. It usually decreases upstream and increases, in a vertical section, towards the bottom. Changes in salinity and water temperature determine water density and influence circulation patterns, allowing the tracking of water circulation in estuaries.

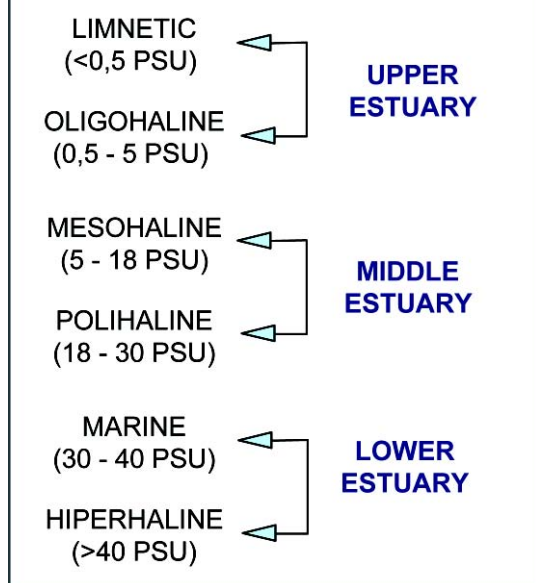
**BOX 8.2**
**Classification of estuarine zones according to the Venice system**

Freshwater discharge affects estuarine ecosystems in a complex way, integrating and linking biological, physical and chemical variables. Generally, fresh water has high contents of  $\text{Ca}^{2+}$ ,  $\text{SiO}_2$ , Fe, N and P due to chemical weathering or erosion of bedrock and washout of fertilizers or organic waste from land. In contrast, seawater contains high concentrations of electrolytes such as  $\text{Cl}^-$ ,  $\text{Na}^+$ ,  $\text{SO}_4^{2-}$  and  $\text{Mg}^{2+}$ . While mixing, salinity behaves conservatively and accordingly has a low involvement in biological and chemical processes. Hence, it is often used as a mixing index. A mixing diagram of conservative material and salinity would show a linear line (Box 8.3).

Concave and convex lines would be observed when a material behaves non-conservatively. A concave line shows the sinking pattern of material according to biological (e.g., photosynthesis) or chemical processes (e.g., adsorption) whereas a convex line indicates addition of material from an estuary that may be created by degradation of organic material or desorption processes.

In coastal areas the influence of oceanographic conditions, e.g., winds, tides and freshwater discharge regimes, are responsible for sudden variations in chemical concentrations in the water,

both in time and space. Changes in water chemistry can be indicative of water quality degradation. Ensuring good water quality is fundamental to the maintenance of life and normal uses of estuaries and coastal areas (e.g., recreational, tourism, fishing, etc).

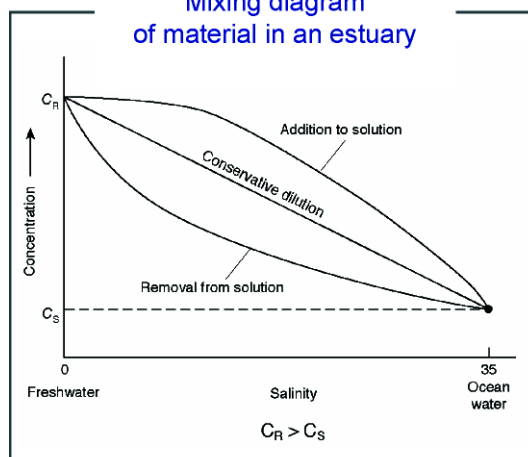
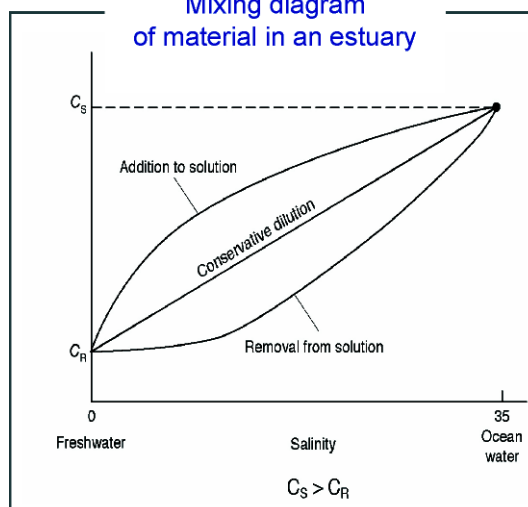
**BOX 8.3 [A]**
**Mixing diagram of material in an estuary**

**BOX 8.3 [B]**
**Mixing diagram of material in an estuary**

**TABLE 8.1**

<b>PARAMETERS</b>	<b>UNITS</b>	<b>EQUIPMENT/METHOD NEEDED</b>	<b>WHERE TO SAMPLE</b>	<b>WHEN TO SAMPLE</b>	<b>ECOLOGICAL RELEVANCE</b>
<b>Water temperature</b>	°C	Thermometre Electronic water temperature metre (thermistor)	- Middle channel and river plume - Longitudinal axis: each 1.5 km x 3 depths - At least three depths (surface, bottom, middle)	- Spring and neap tides - Along a tidal cycle - Different Seasons	affects the solubility of many chemicals influences oxygen solubility, water density and occurrence of stratification Information about periodic?? discharges Triggering factor for algal blooms and species reproductive cycles
<b>Salinity</b>	PSU, ‰, none	Refractometre Salinometre Conductivity metre	- Middle channel and river plume - Longitudinal axis: each 1.5 km x 3 depths - At least three depths (surface, bottom, middle)	- Spring and neap tides - Along a tidal cycle - Different Seasons - During exceptional flow regimes	Information about water circulation patterns, Important to species distribution Influence on water properties (e.g., dissolved oxygen or water density)
<b>Dissolved oxygen</b>	%, mg L <sup>-1</sup>	Electronic oxygen sensor and metre Winkler titration	- Transverse transect between margins - Longitudinal axis: each 1.5 km x 3 depths (summer stratification) - Along estuary channel and subsidiaries - Near potential impact sources (industries, sewers, etc)	- Day/night variation - Different Seasons	Respiratory metabolism of most aquatic organisms Affects the solubility and availability of nutrients Information about bacterial decomposition, Limiting to organisms (0.5-3 mg L <sup>-1</sup> )
<b>pH</b>	None	Colourimetric methods (in non-coloured water, e.g., by algal blooms): - visually - electronically	- Middle channel - Longitudinal axis: each 1.5 km - Transverse transect between margins - Near potential impact sources (industries, sewers, etc) - different depths (summer stratification)	- Day/night variation	Indication of pollution sources Associated with oxygen concentrations (low pH in low oxygen conditions) Solubility determinant of chemicals in the water and, consequently, availability to organisms.

**TABLE 8.1 – cont.**

<b>PARAMETERS</b>	<b>UNITS</b>	<b>EQUIPMENT/METHOD NEEDED</b>	<b>WHERE TO SAMPLE</b>	<b>WHEN TO SAMPLE</b>	<b>ECOLOGICAL RELEVANCE</b>
<b>Turbidity</b>	NTU (Nephelometric units) Metres (Secchi disk) mg L <sup>-1</sup>	Secchi disk Turbidimetre	<ul style="list-style-type: none"> <li>- Middle channel</li> <li>- Longitudinal axis: each 1.5 km</li> <li>- Transverse transect between margins</li> <li>- at ETM (estuarine turbidity maximum) zone</li> </ul>	<ul style="list-style-type: none"> <li>- Spring and neap tides</li> <li>- Along a tidal cycle</li> <li>- Different seasons</li> <li>- During exceptional flow regimes</li> </ul>	<p>Influence light penetration and primary productivity (planktonic and benthic)</p> <p>Provides attachment for bacteria and metals</p>
<b>Nutrients (Nitrogen, Phosphorus, Silicon, etc)</b>	µmol L <sup>-1</sup>	Test Kits/ Colourimeter (not accurate when nutrient levels are low) Spectrophotometer	<ul style="list-style-type: none"> <li>- Middle channel</li> <li>- Transverse transect between margins</li> <li>- Near potential impact sources (industries, sewers, etc)</li> <li>- different depths (summer stratification)</li> </ul>	<ul style="list-style-type: none"> <li>- weekly-biweekly sampling</li> <li>- end of flow season</li> <li>- peak of high flow season (maximum river water flushing)</li> <li>- several seasons</li> </ul>	<p>Influence on primary productivity</p> <p>Development of algal blooms (eventually toxic)</p> <p>Risk of eutrophication (N and P)</p> <p>Changes in Si:N:P ratio (16:1:1) affects phytoplankton succession</p>
<b>Chlorophyll a</b>	µg L <sup>-1</sup> for plankton species and mg m <sup>-2</sup> for attached species	Water filtration with a glass fibre filter (posterior determination in a fluorometre or spectrophotometre) In situ fluorometer	<ul style="list-style-type: none"> <li>- Middle channel</li> <li>- Longitudinal axis: each 1.5 km</li> <li>- Transverse transect between margins</li> <li>- at ETM (estuarine turbidity maximum) zone</li> </ul>	<ul style="list-style-type: none"> <li>- weekly-biweekly sampling</li> <li>- several seasons</li> </ul>	<p>Productivity and trophic status of a body of water</p> <p>Indicator of algal blooms</p>

## ■ 8.B. WATER CIRCULATION

The objective of this chapter is to provide basic information about how to assess water circulation in estuaries and coastal areas using estimations of the current speed, flow rate and residence time.

### WHAT IS WATER CIRCULATION?

Water circulation is the result of a complex combination of forces produced by tides, wind and differences in water density.

The most obvious currents in estuaries result from the movement of water caused by tides. Tidal currents often reach their highest speed between high and low tides in the middle of the estuary. Winds also determine the circulation pattern and contribute to the vertical mixing of the water column. The density of water depends on the temperature and the amount of salt **dissolved** in the water. Cold, salty water is denser and warm fresh water is the least dense. When the difference in



Fig. 8.2  
Guadiana estuary (photo: L. Chcharo)

can be assessed from estimations of current speed, flow rate and residence time.

### MEASURING WATER CURRENTS

Current speed may be measured simply by analysing the time necessary for a floating object to travel over a known distance (e.g., between two boats, or two buildings) in a certain direction.

#### BOX 8.4

Digital flowmetre used to measure flow and to measure filtered water volume by a plankton net

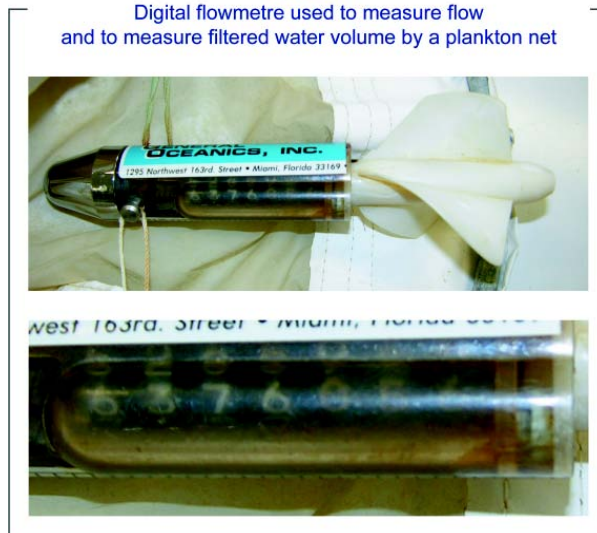

density prevents mixing between the surface and bottom layers, stratification may occur. Stratification reduces mixing and dilution of materials (e.g., pollutants), and also hampers oxygenation of deeper bottom layers.

Non-tidal currents are caused by the fresh water discharge flow into an estuary and by the resulting differences in densities. In comparison with tidal currents, non-tidal currents move slowly.

Water circulation in estuaries and coastal areas

However, since water circulation may vary with depth due to density differences, it may be necessary also to consider estimations of current speed in deeper layers of the water column. In this case, a normal small bottle filled with 250 ml of water can be suspended with a rope several metres below a surface floating device (e.g., a ball). More accurate results can be obtained by using a current metre. However, current metres are usually expensive. For less accurate determinations a flow metre, as the one used in plankton

nets (Box 8.4), can also be used to estimate current speed. In this case, the current speed ( $m\ s^{-1}$ ) can be easily derived from the flow metre readings: FR, number of final rotations; IR, number of initial rotations; and T (in seconds), duration of the immersion from an anchored vessel or quay. From the flow metre a calibration factor, CF, expressed in metres/rotation and indicated in the equipment manual, is used with these variables to calculate current speed:

$$\text{current speed (ms}^{-1}\text{)} = ((FR - IR) \times CF) / T$$

**BOX 8.5**  
A stream gauge  
used to measure river flow



#### WHAT IS RIVER INFLOW AND HOW IS IT MEASURED?

An inflow is the flow of water into a stream, lake, reservoir, basin, river, etc. The fresh water input to an estuary or coastal zone is measured by the discharge or rate of freshwater flow.

The Discharge or Rate of Flow (RF) is the volume of water flowing through a channel cross-section in unit time ( $m^3\ s^{-1}$ ) (Box 8.5), and can be calculated using the formula:

$$R_f (m^3 s^{-1}) = A * (h_f(m) - h_0(m))^B$$

Where:

- $h_f$  - final height,
- $h_0$  - initial height,
- A - gauging section - cross-section of the open channel in which depth and velocity measurements are made, and
- B - time between observations (seconds).

#### WHAT IS RESIDENCE TIME OR FLUSHING RATE?

The flushing rate is defined as the amount of time needed for a parcel of water to travel through a certain part of a river/estuary to the sea and permanently leave an estuary. It is somewhat difficult to measure or calculate the flushing rate of water because there are many factors interfering with the water mass circulation, namely tidal range (i.e., spring or neap), freshwater input and wind speed and direction.

In its simplest form, the flushing time is defined as the time needed to drain a volume,  $V$ , through an outlet,  $A$ , with current velocity,  $v$ . More specifically, the flushing time,  $t_f$ , of an estuary can be defined as the time needed to replace its freshwater volume,  $V_{f_r}$ , at the rate of the net flow through the estuary (the river discharge rate, RF):

$$t_f = V_{f_r} / RF$$

Calculation of the flushing time using this method requires knowledge of the volume of the estuary (which is acquired through a detailed depth survey), measurement of the river discharge rate, RF (which can be acquired at a single point at the inner end of the estuary), and a survey of the salinity distribution through the entire estuary.

The observational requirements of a complete survey of the salinity distribution in an estuary can be demanding in time and financial resources. Efforts to derive flushing times from a smaller observational database introduce additional assumptions. The „tidal prism“ method starts from the concept that a volume of sea water,  $V_{T_r}$ , enters an estuary with the rising tide, while a freshwater volume,  $V_{R_r}$ , enters the estuary during a tidal cycle (rising and falling tides). It assumes that the salt water volume,  $V_{T_r}$ , is completely mixed with

the freshwater volume,  $V_R$ , at high tide, and that the combined volume,  $V_T + V_R$ , representing the mixture leaves the estuary during the falling tide. The salinity of the freshwater volume,  $V_R$ , is zero. If the salinity of the salt water brought in by the rising tide is  $S_0$ , the salinity,  $S^*$ , of the mixed water in the volume,  $V_T + V_R$ , is easily calculated from:

$$(V_T + V_R)S^* = V_T S_0$$

and found to be:

$$S^* = S_0 V_T / (V_T + V_R)$$

This gives the freshwater fraction:

$$f^* = (S_0 - S^*) / S_0 = 1 - S^* / S_0$$

as:

$$f^* = V_R / (V_T + V_R)$$

The flushing time was previously defined as:

$$t_F = (f^* V) / R_F$$

where:

$R_F$  - the river discharge rate or freshwater volume per unit time.

In the tidal prism method the unit of time is the tidal period,  $T$ , so  $RF = V_R / T$ . Using the result for the freshwater fraction obtained under the assumptions of the tidal prism method:

$$t_F = TV / (V_T + V_R)$$

The combined volume,  $V_T + V_R$ , represents the difference between high water and low water, therefore often being called the tidal prism. It is the only quantity (besides knowledge of the estuarine volume) required to calculate the flushing time with this method and can be easily obtained from tidal gauge records.

However, the assumptions of the tidal prism method are never completely met in real estuaries. Mixing of the two volumes,  $V_T$  and  $V_R$ , is never complete and some of the mixed water that leaves the estuary with the ebb tide will enter it again with the rising tide. The flushing time derived from the tidal prism method represents the shortest possible time during which the entire freshwater fraction of an estuary can be removed; in other words, it represents a lower limit for any flushing time calculation.

## 8.C. STRUCTURE OF BIOTA

Aquatic organisms are very sensitive to changes in the quality of water. They also change in response to a wide variety of pollutants. Thus, individually or in a group (structure and composition of communities), they provide important information about the environmental conditions in which they live, in this case, in estuaries and coastal areas. The objective of this chapter is to provide basic information about sampling, processing and analysis of biotic components necessary for basic assessment of the biotic structure and composition of estuaries and coastal areas.

### WHAT LEVEL OF ANALYSIS SHOULD BE CONSIDERED IN BIOTIC ASSESSMENTS: INDIVIDUAL OR COMMUNITY LEVELS?

Changes in the biotic structure of estuarine and coastal areas can be assessed based on community or individual analyses. At the community level, usually changes in species abundance and biomass are analyzed. At the individual level, physiological and biochemical characteristics are studied. Studies at the community level have the advantage of providing a global analysis of a system's functioning. However, indicator species (particularly susceptible to certain changes) respond more rapidly to impacts than do communities (except with acute impacts) so that impacts may take a long time to become conspicuous in a community. As a consequence, mitigation and remediation actions are taken only in more advanced stages of disturbance. In contrast, analysis at the individual level rapidly reflects changes in an ecosystem allowing

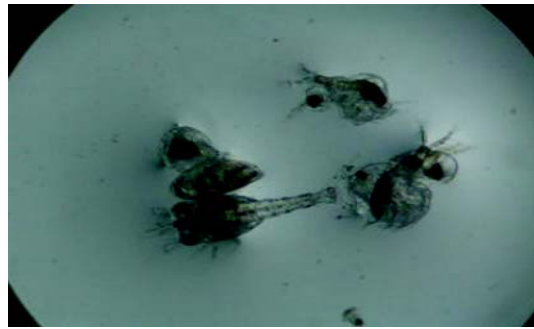

Fig. 8.3  
zooplankton  
(photo: L. Chicharo)

proactive actions to be taken before changes at the community level can be perceived. However, with individual analyses usually only a few species are analyzed and a general understanding of interrelations between species is lost.

Changes at the community level are basically focused on the analysis of species abundance and biomass. Based on a knowledge about the number of individuals per species, several diversity indices (Shannon-Wiener, Pielou, Margalef, evenness, average taxonomic diversity, etc) can be calculated. At the individual level, analysis is focused on the determination of physiological (rates of oxygen consumption and ammonia excretion) and biochemical (RNA/DNA) response to environmental disturbances.

When in the presence of acute impacts that cause sudden and drastic changes in the environment that are responsible for high morbidity and mor-

### BOX 8.6

#### Biotic components

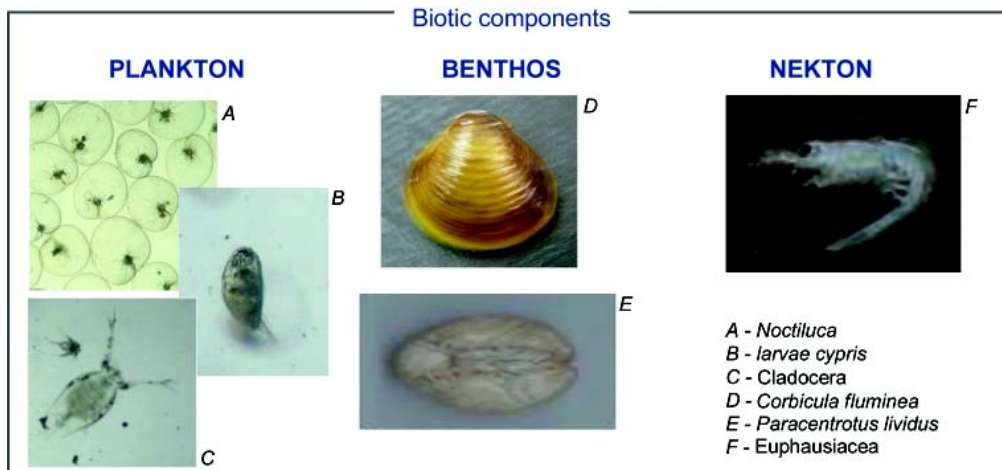



tality rates, conspicuous effects on a particular species or area can be noticed, indicating what and where to sample. In this case, individual sampling could be adequate.

When environmental changes result from long-term disturbance, chronic effects may occur. These are less noticeable than acute effects and usually last long enough to provoke changes in a community.

**WHAT BIOTIC COMPONENTS SHOULD BE ANALYZED AND WHAT METHODS SHOULD BE USED?**

Selecting the most appropriate biotic components to analyze in estuaries and coastal areas depends on the aims of a study, the type of disturbance, the environmental characteristics in an area and, often decisively, the availability of human and material resources (Box 8.6)

Sampling and processing of estuarine and coastal water samples uses traditional sampling methods for each particular group, but attention must be drawn to the factor of salinity (Box 8.7). In fact, for preservation, conservation or dilutions, osmotic variations may affect organisms, particularly smaller ones, resulting in changes in shape (affecting length measurements) that, in some cases, may cause tissue rupture and loss of biomass. Moreover, pollutants and contaminants may behave differently in the presence of different salinity values, so salinity is a key-factor also for toxicity assessments.

**HOW TO ASSESS CHANGES IN STRUCTURE AND COMPOSITION OF BIOLOGICAL COMMUNITIES**

**Diversity indices**

A diversity index is a mathematical measure of species diversity in a community. Diversity indices provide more information about community composition than simple species richness (i.e., the number of species present); they also take the relative abundances of different species into account. Diversity indices (Shannon-Weaver, Margalef, Pielou, Shannon, species richness and evenness) provide important information about the rarity and commonness of species in a community. Results are dependent on sample size and do not reflect phylogenetic diversity. The ability to quantify di-

versity in this way is an important tool for understanding community structure and changes.

Typically, a decrease in diversity and an increase in species dominance tend to be interpreted as indicative of some type of environmental stress.

**BOX 8.7  
Plankton and benthos samplers**



Vertical plankton net



Bottom dredge



Corer



Grab



Secchi disk

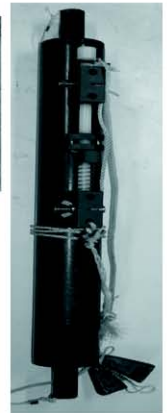

Water sampler

**TABLE 8.2**  
Summary table of sampling, laboratory processing and analysis of different biotic components

BIOTIC COMPONENT	SAMPLING EQUIPMENT AND METHOD	LABORATORY PROCESSING	DATA AND STATISTICAL ANALYSIS	ECOLOGICAL RELEVANCE
Bacteria (coliforms)	3 x 100 ml water samples collected also near sewer and waste treatment discharge points. Collect samples in different tides to evaluate dilution.	Incubation in Petri dishes	Coliform results are reported as Colony Forming Units (CFU) of Total Coliform bacteria counted in 100 ml of water submitted or, Most Probable Number (MPN) per 100 ml of water	The presence of coliform contamination from human or animal wastes indicates water quality degradation.
Phytoplankton	3 x 250 ml water samples collected from bottles (e.g., Van Dorn, Niskin) or pumps	Sedimentation through 10-40 µm mesh filters	Species composition and abundance Biomass requires calculation of cell volume Diversity indices	Phytoplankton is a Primary Producer and therefore basic to all food webs. Blooms of toxic algae cause water quality degradation.
Zooplankton and ichthyoplankton	Nets (mesh size depends on target individual's size) equipped with flowmetre Sampling speed – 2 knots Tow duration – 5-10 minutes, depending on water turbidity (e.g., excessive suspended materials can clog nets)	Sieving and identification Biomass determinations (ash free dry weight, AFDW)	Species composition and abundance Biomass Diversity indices Average taxonomic diversity	Zooplankton and ichthyoplankton are first-level consumers and responsible for transference of energy and matter to upper trophic levels.
Benthos	Dredges (e.g., Van Veen) for epifauna and infauna Also, photographs or video images can be used for epifauna Traps can be used for specific studies (e.g., predator-prey relations)	Sieving and identification Individual measurements Biomass determinations (ash free dry weight, AFDW)	Species composition and abundance Biomass Diversity indices Average taxonomic diversity ABC plots (Abundance/Biomass comparison)	Benthic species are a major link in the food chain. Moreover, they remove sediment particles – bioturbation – increasing oxygenation into deeper layers of bottom sediments. Also, they may retain contaminants and pollutants in their bodies, acting as bioaccumulators and bioindicators.
Macroalgae Macrophytes	Dredges Scuba-diving In situ fluorometre	Identification Biomass determinations (ash free dry weight, AFDW)	Species composition and abundance Biomass Diversity indices Average taxonomic diversity	Macroalgae and macrophytes are important reservoirs of nutrients, helping to control eutrophication. However, assessment of limitation by light is necessary. Macroalgal mats are used as nursery areas for several species of fishes.
Nekton	Nets Capture and recapture	Identification Individual measurements Biomass determinations (ash free dry weight, AFDW)	Species composition and abundance Biomass Diversity indices Average taxonomic diversity	Some nektonic species are migratory or use estuaries and coastal areas for reproduction and as nurseries. Nektonic species usually represent the largest part of coastal fisheries.

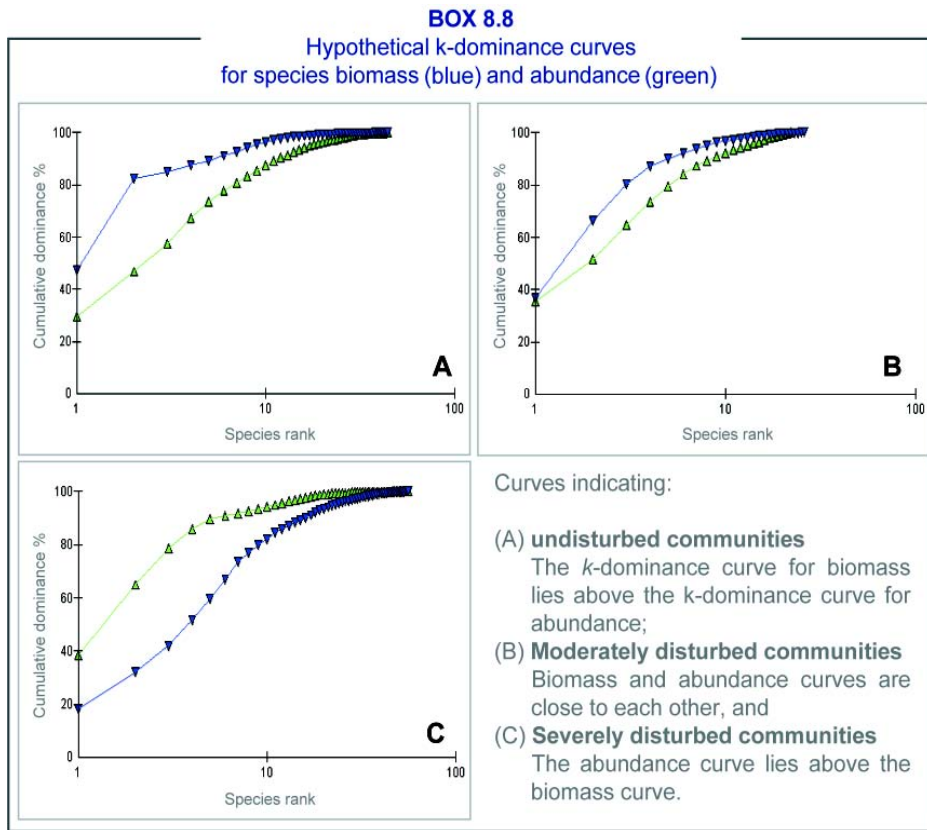

This interpretation may, however, be an over-simplification of the situation. In fact, in situations where disturbance is minimal, the observable decrease in species diversity is caused mainly from competitive species exclusion. However, when disturbance is intermediate, diversity reaches maximal values that usually drop in severe disturbance situations. Thus, diversity indices may indicate the presence of changes but not the level of the impact that cause them (low, medium or high). For this purpose Abundance/Biomass comparison plots (ABC) and the Taxonomic diversity index (Clarke & Warwick, 2001) provide more adequate results.

**Abundance/Biomass comparison (ABC) plots**

The ABC method involves the plotting of separate *k*-dominance curves (cumulative ranked abundances plotted against species rank, or log species rank) (Lambhead et al., 1983) for species abundance and species biomass and comparing the shape of the curves (Clarke & Warwick, 2001). Species are ranked in order of importance in terms of

abundance or biomass on the x-axis (logarithmic scale) with percentage dominance (cumulative scale). Different types of curves result according to the level of disturbance:

- ▶ in **undisturbed communities** the biomass is dominated by one or few larger species, leading to an elevated biomass curve. Each of these species, however, is represented by fewer individuals so they do not dominate the abundance curve, which shows a typical diverse, equitable distribution. Thus, the *k*-dominance curve for biomass lies above the

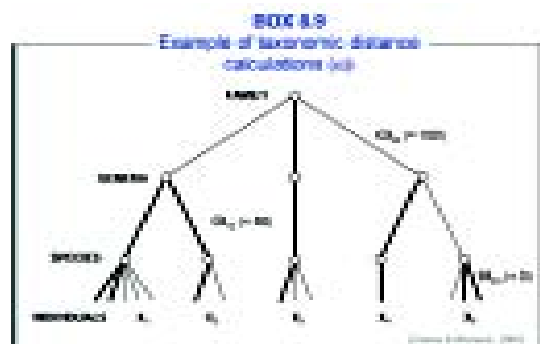

k-dominance curve for abundance over its entire length;

- ▶ in **moderately disturbed communities** large competitive dominants are eliminated and the inequality in size between the numerical and biomass dominants is reduced so that the biomass and abundance curves are similar;
- ▶ in **severely disturbed communities**, communities become increasingly dominated by one or few opportunistic species that, despite their dominant number, do not dominate biomass because they are small-bodied. Hence, the abundance curve lies above the biomass curve throughout its length (Box 8.8).

### Taxonomic diversity

One measure, which addresses some of the limitations of diversity indices calculations, is the average taxonomic diversity. This measure, proposed by Warwick & Clarke (1995), considers the taxonomic position of individuals.

Using traditional diversity indices, the same outcome will result from a sample composed of 10 individuals of the same genera or 10 individuals from different genera, but the ecological meaning is different. Biodiversity is, of course, higher in the second case. The average taxonomic change ( $\Delta$ ) of a sample is then defined as the average „taxonomic distance apart“ of every pair of individuals in a sample or the expected path length between any two individuals chosen at random (Warwick & Clarke, 1995) - Box 8.9.

### Physiological stress indicators

Ecophysiological indices have been widely used to assess changes in physiological conditions of individuals caused by environmental disturbances. Changes in individual condition can be noticed before external evidence of debility and allows estimations of future survival. Therefore, using these indicators it is possible to detect changes that will only cause mortalities after long periods of cumulative impact

### Rates of oxygen consumption and ammonia excretion

Studies of the physiology and rates of oxygen consump-

tion ( $VO_2$ ) and ammonia excretion ( $VNH_4-N$ ) characterize the energy loss and gain associated with metabolic processes occurring in aquatic individuals. The O:N index, a ratio between oxygen consumption and ammonia excretion rates, indicates the proportion of proteins catabolized for metabolic energy requirements, in relation to lipids or carbohydrates. Therefore, a high protein catabolism compared to lipids or carbohydrates results in a low O:N ratio. Low O:N values have been associated with food limitations (Kreeger & Langdon, 1993). Widdows (1985) demonstrated that  $O:N < 30$  indicates the presence of stress factors to mussels.

### Biochemical indicators- nucleic acid ratios

Determination of physiological conditions by measurement of the RNA/DNA ratio has been used on a wide range of aquatic organisms (Chícharo & Chícharo, 1995; Chícharo et al., 1998). Organisms in good condition tend to have a higher RNA/DNA ratio and organisms with a RNA/DNA ratio below 1 („minimum ratio“) are considered to be in very poor condition with their survival threatened. The use of this index is based on the assumption that the amount of DNA, the primary carrier of genetic information, is stable under changing environmental situations, while the amount of RNA is directly involved in protein synthesis and by inference, with nutritional condition, and therefore more susceptible to negative influences of the environment, e.g., pollution or low prey availability.

RNA/DNA changes have been used successfully in the evaluation of changes in estuarine biota (fish larvae) caused by modifications in river discharge volumes into an estuary. Moreover, in coastal areas this ratio has been demonstrated to be sensitive to changes in oceanographic conditions (changes in currents or presence of upwelling). In fact, Chícharo et al. (1998) and Chícharo et al. (2003) related these factors to the decrease of conditions in sardine larvae and to recruitment failure (Box 8.10).

### Nutrient ratios

The enrichment of catchment areas in N and P (but not Si) caused by human activities (cultural eutrophication) has been hypothesized as leading

**BOX 8.10**

**A. Vertical distribution of salinity during a winter upwelling event off northern Portugal.** Thick solid line represents the Western Iberian Buoyant Plume (WIBP) located over the shelf. River runoff with high values of chlorophyll accumulates here and generates a persistent buoyant plume.

**B. Variation of RNA/DNA ratios of sardine larvae reflecting their physiological conditions.** High ratios mean that RNA is being synthesized, which indicates cellular growth and therefore reflects good environmental conditions. Physiological conditions of sardine larvae evaluated by RNA/DNA ratios were higher in areas remote from the coast, which was induced by nutrient transport by currents resulting from upwelling.

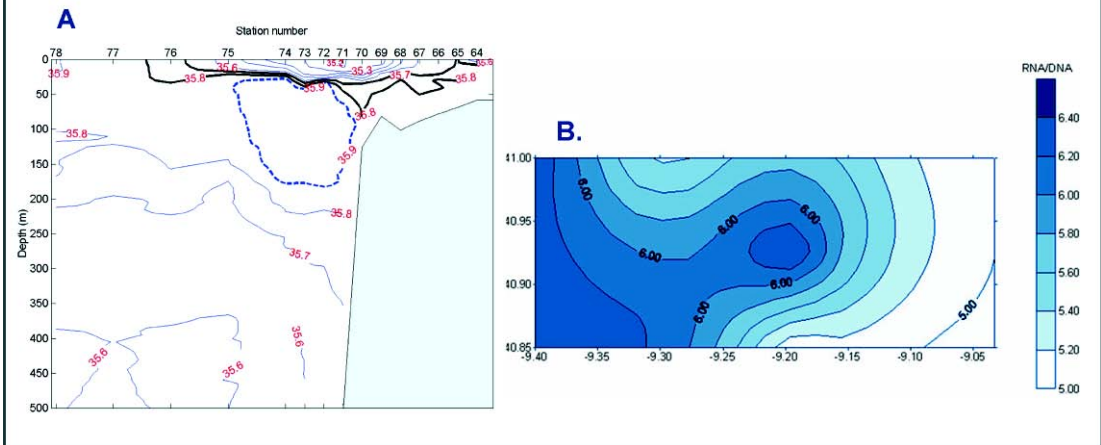

to a shift from diatom-based to non-diatom-based phytoplankton food webs (cyanobacteria and dinoflagellates), due to exhaustion of Si supplies. The transition of ecosystems from siliceous-based to non-siliceous-based phytoplanktonic communities has been associated with deleterious effects on water quality (Smayda, 1990; Turner & Rabalais, 1994). Redfield et al. (1963) proposed a Si: N: P ratio of 16:1:1 as indicating an adequate nutrient ratio for diatom growth. This ratio is within the minimum range for freshwater phytoplankton, since it has been shown that dissolved silicate demand by freshwater diatoms is higher than that by marine species (Paasche, 1980). Nutrient ratios used to demonstrate potential nutrient limitation are calculated using molar quotients between the in situ concentrations, and delimited by values of Si: N=1, N: P=16 and Si: P=16. These define six different areas, each characterized by potentially limiting nutrients in order of priority, when Si: N, N: P and Si: P ratios are calculated and plotted on an XY logarithmic graph (Rocha et al., 2002) Box 8.11.

**BOX 8.11**

**Nutrient limitation in a water column according to Si: N, N: P and Si: P ratios. In each delimited section, nitrogen (N), phosphorus (P) and silica (Si) are ordered by decreasing degree of limitation**

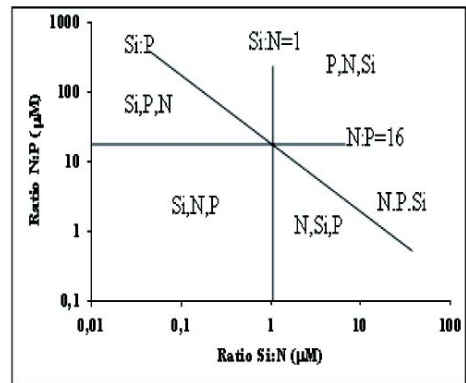



## PART THREE: MANAGEMENT



## ■ 9.A. PHYTOREMEDIATION OF SOILS

A variety of technical soil remediation methods exists, however, most of them are very expensive, technically complex and exert undesirable side effects on the environment.

Phytoremediation is a cost-effective and environmentally friendly technology that uses plants to extract, degrade or immobilize contaminants from soil, water and sediments.

While phytoremediation has broad applicability, this chapter will present an overview of the current state-of-the-art of the application of phytoremediation and emphasize its applications to toxic heavy metals.

### INTRODUCTION

When describing soil as a habitat for biological life, the upper 30-cm layer of the earth's crust generally is considered. It is in this zone that most biological processes take place. Soil from this zone also is responsible for dust resuspension, involuntary pollutant ingestion by children and grazing animals (Thornton, 1982) and contamination of surface runoff. It is also known as the arable layer, where most agricultural activities are performed. Agricultural soil is regularly mixed in the course of plant bed preparation, which results in a rather uniform distribution of pollutants within this layer.

Phytoremediation of soil is a variety of cost-effective (Tab. 9.1) remediation methods using plants, which are effective to a depth that is delimited by their rooting zone. With a few significant exceptions, this is not deeper than 50 cm in the case of herbaceous plants (Kucharski et al., 1998; Raskin & Ensley, 2000). In some cases, deep-rooting trees are being used to extract organic solvents from deep aquifers (Negri et al., 1996).

### METHODS OF PHYTOREMEDIATION

#### Phytoextraction

##### *How does it work?*

The method is based on the ability of some plants to take up contaminants from soils by their roots and transport them to aerial parts, e.g., leaves. Such plants are known for their ability to accumulate and tolerate significant amounts of contaminants. Contaminants are removed from the envi-



Fig. 9.1  
Phytoextraction of lead in the vicinity  
of a former zinc smelter  
(photo: E. Wysokinska)

ronment by harvesting and carefully disposing the plants.

##### *Where?*

The technology is applicable to moderately contaminated land.

##### *What plants?*

Basic requirements for plant species used are as follows: production of high biomass, good accumulation properties in above-ground parts, and tolerance to the local climate. The most commonly used species for metal phytoextraction are those of the Brassicaceae family, e.g., Indian mustard.

**TABLE 9.1**  
Relative costs of phytoextraction

STEP OF PROCESS	% of total cost
Field preparation	<1
Fertilizers and plant protection	<1
Chemicals for plant protection	<1
Plant care	<1
Irrigation	<1
Seeds and planting	7
Sampling and monitoring	7
Amendments	67
Contaminated crop disposal	<1
Scientific supervision	15
<b>Total</b>	<b>100</b>

**How to apply?**

The efficiency of this technology depends on biomass production and contaminant concentration. These factors in turn are dependent upon complex interactions among plant physiology, soil chemistry, hydrogeology and climate. The effectiveness of phytoextraction is often enhanced through the use of soil and plant amendments. The role of soil amendments is to facilitate the uptake of metals from soils to plants. Usually various chelators are used for that purpose (EDTA, DTPA, HEDTA) followed by organic (citric or acetic) acids.

**Phytostabilization****How does it work?**

This method converts soil contaminants into inert, immobile elements using metal tolerating plants. The mechanism may include absorption, adsorption, accumulation, precipitation or physical stabilization of contaminants in the root zone. Plants with well-developed root systems prevent contaminant migration via wind and runoff through the soil profile. Plant root biochemical activities can change soil pH as well as convert metals from a soluble to insoluble form.

**Where?**

Phytostabilization may be applicable to large areas of contaminated soil, sludge and sediments that are not amenable to alternative forms of treatment; and for remediation of heavily polluted sites.

**What plants?**

The best are carefully selected indigenous species of grass and shrubs, which develop a dense and strong root system. Good results were achieved using, e.g., *Deschampsia caespitosa*, in the case of heavily metal-polluted soils.

**How to apply?**

Phytostabilization of heavily polluted sites may be achieved using a combination of chemical and biological methods.

- ▶ the upper layer of soil is treated first with chemicals (e.g., lime, commercial fertilizers as needed) to adjust soil pH, fertilize, and to transform metal compounds into non-soluble forms;

- ▶ the next step is to develop a robust plant cover to reinforce the soil surface, to maintain the desired soil chemical conditions and to minimize soil transport processes (e.g., erosion and wind transport) (Vangronsveld et al., 1995, Kucharski & Nowosielska, 2002).

**Rhizofiltration**

This method is applicable to surface water, wastewater and (extracted) ground water contaminated with low concentrations of contaminants. For this purpose, aquatic plants or terrestrial plants (grown hydroponically) are used. The mechanism of rhizofiltration is based on adsorption or precipitation of contaminants onto plant root surfaces or bioaccumulation in plant tissues. Contaminants are then removed by physically removing and disposing of the plants (US EPA, 1997).

**Rhizodegradation**

This method uses plants to degrade organic contaminants in soil by microbial activity in the rhizosphere (root zone). In this application, it is often the microbial community associated with the rhizosphere that is responsible for the chemical degradation. Plant roots can affect this process by increasing soil aeration and changing soil moisture content. Rhizodegradation is also known as plant assisted biodegradation (US EPA, 1997).

**Phytodegradation**

This method uses plants to degrade organic contaminants within plant tissues by metabolic processes. It may be applicable in situations where poor soil conditions or the concentrations of soil contaminants preclude the actions of natural biodegradation (US EPA, 1997).

**Phytovolatilization**

This method uses plants to volatilize or transpire contaminants. Contaminants are transported from water or soil through plants to the atmosphere (US EPA, 1997). This approach is applicable in situations where reduced risks associated with atmospheric volatilization justify the transfer from one environmental compartment to another.



### Land farming

This method is a relatively simple, cost effective method of soil clean up that is achieved through routine agricultural practices performed on contaminated land. The functional process in this case is natural attenuation, i.e., oxidation of pollutants, microbial decomposition in the root zone and pollutant destruction by UV radiation.

This approach is implemented with or without the use of plants and uses standard agricultural operations such as plowing, harrowing, seedbed preparation and harvesting. The procedure is repeated, exposing new layers of pollutant-contaminated soil to aeration and solar radiation. Crops grown in such situations are not to be consumed. This method is used for cleaning large areas of land that are contaminated with biodegradable organic compounds such as oil, gasoline and other organic chemicals. The approach can be applied either *in situ* or *ex situ* using prepared beds. The advantages of this technology are simplicity and cost effectiveness. (Reisinger et al., 1996).

### PRACTICAL IMPLEMENTATION OF PHYTOREMEDIATION

Phytoremediation appears to be a „natural technology” - simple and uncomplicated. However, phytoremediation is relatively new and continues to evolve. There are some important factors that should be observed carefully in order to achieve the expected results and to avoid disappointments:

- ▶ plant species used for phytoremediation will be **different** depending on the purpose;
- ▶ it is desirable to use an **indigenous species**, one that is locally adapted and resistant to the substances polluting the soil;
- ▶ optimally, the selected plant should **not require special care**, should be **tolerant** to naturally variable weather conditions and should grow well on the type of soil to be remediated;
- ▶ for **optimal performance**, regular watering and fertilizing may be necessary; and
- ▶ the use of **exotic plant species**, even those shown to be very effective elsewhere, is potentially problematic. Cultivation procedures will need to be developed specifically

for the plant/environment (Kucharski et al., 1998). This developmental process can be time consuming and expensive.

### Treatability study

Full-scale phytoremediation projects are generally preceded by **preliminary experiments**, known as „treatability studies”, performed under a controlled environment in laboratories, growth chambers or greenhouses. The experiments are carried out in pots containing the contaminated soil to be cleaned-up or stabilized. These studies seek to:

- ▶ **identify the plant species** that will grow well on the target soil, tolerate the contamination and perform appropriately in terms of treatment;
- ▶ calculate the optimal **cultivation conditions** (e.g., fertilizing and irrigation); and
- ▶ calculate the **amount of soil amendments** to be added in order to mobilize contaminants (in the case of phytoextraction) or to immobilize contaminants (in the case of phytostabilization).

When the distribution of contaminants in the target area is suspected to be non-homogenous, a **strip test** for verification of phytoextraction efficiency in natural conditions is recommended (Sas-Nowosielska et al., 2001).

These measures are suggested to optimize the potential for successful phytoremediation by considering critical points in the decision-making process (Box 9.1).

### IMPLEMENTATION OF PHYTOEXTRACTION AND PHYTOSTABILIZATION

Considering the practical aim of this manual, only phytostabilization and phytoextraction are currently ready for widespread, full-scale application.

#### Phytoextraction

Phytoextraction will be most applicable in **large areas that are slightly above regulatory limits**. Once it has been shown to be practical by treatability tests, a number of field-scale factors need to be considered including:

- ▶ site characterization;
- ▶ seedbed preparation;

- ▶ planting;
- ▶ biomass production;
- ▶ amendment application;
- ▶ harvesting; and
- ▶ crop disposal.

The success of a phytoremediation process depends on the amount of biomass produced per unit time that allows for rapid removal of pollutants (phytoextraction), or to thoroughly cover the contaminated spot (phytostabilization) - Fig. 9.2. Therefore, those areas that support rapid plant growth over the longest growing period would be the best locations for successful phytoremediation.



Fig. 9.2  
Sunflowers - a good species for phytoextraction  
(photo: N. Slabon)

An important component of phytoextraction is environmentally **responsible crop disposal**. Successful phytoextraction will result in highly contaminated biomass, which may be considered as hazardous waste. In a large-scale deployment, the amount of material requiring disposal may be quite large, e.g., tens of tons per hectare. Disposal may include a combination of:

- ▶ volume reduction (e.g., composting);
- ▶ incineration;
- ▶ disposal at a hazardous waste dumping site; and
- ▶ potential recycling.

Another important consideration is the time required to reach regulatory criteria in the clean up. Phytoextraction may take **multiple crops** to remove sufficient quantities of the contaminant. Time will need to be balanced against cost and environmental impacts when evaluating the feasibility of phytoextraction.

### Phytostabilization

In practice, phytostabilization is the **most commonly applied** form of phytoremediation.

Field deployment of phytostabilization includes the following steps:

- ▶ site characterization;
- ▶ seedbed preparation;
- ▶ amendment application;
- ▶ planting; and
- ▶ plant cover production.

Theoretical knowledge of phytoextraction is very well developed. Experiments have been conducted on various scales and many interfering factors have been identified, however, implementation on a large scale has been limited (Fig. 9.3).

The other methods of phytoremediation are less well developed and may be considered experimental. To date, they have not been shown to be cost-effective and their commercial application is a matter for the future (Kucharski et al., 1998).

### SUMMARY

There are significant differences between the demands of phytostabilization and phytoextraction in terms of the applied plant species.

Phytostabilizing plant species need to create a dense root mat, which would isolate the contami-



Fig. 9.3  
Crop damage due to excess zinc  
(photo: R. Kucharski)

nated soil zone from deeper layers of soil, keep the absorbed pollutants bound in the root mat and prevent wind erosion of contaminated soil (Fig. 9.4).

Phytoextracting plant species, on the contrary, should transfer the pollutants from roots to shoots to allow contaminant removal with the harve-

sted crop. Large above ground biomass and widespread root systems are required for these purposes.



Fig. 9.4  
Root system development (*Deschampsia* sp.)  
(photo: N. Slabon)

Some plant species have a natural ability to take up and concentrate high levels of toxic heavy metals. In the case of nickel, more than 300 plant

species are known to „hyperaccumulate“ this metal. Unfortunately, these plants are generally small and not suited to mechanical harvesting procedures. To date, these plants have been of experimental interest only. The most commonly used plants for metal phytoextraction are those from the *Brassicaceae* family, (e.g., Indian mustard and its cultivars), sunflowers and other crop plants such as corn and sorghum.

Phytoremediation is a promising and environmentally acceptable technology for remediation of contaminated land and water. As with all technologies, the success of phytoremediation will depend on its suitability to the specific application. Careful characterization of the target site and comparative evaluation of the available technologies will help to ensure success (Box 9.2).

BOX 9.1  
Implementation scheme for identification of soil  
phytoremediation method

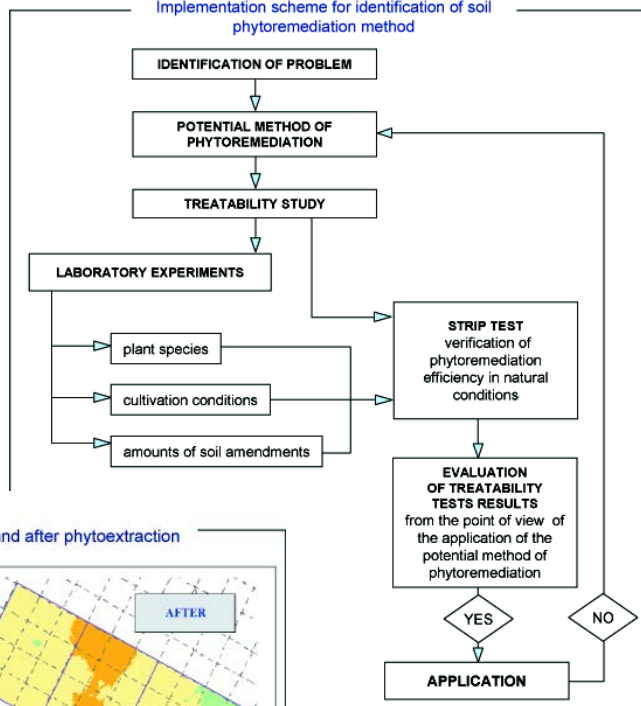

BOX 9.2

Lead concentration in soil before and after phytoextraction

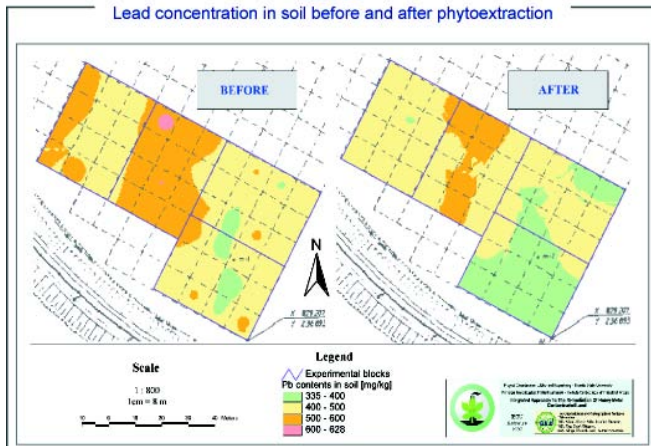

**MAKE SURE TO CHECK THESE RESOURCES:**

Guidelines: chapters 5.B, 5.I-5.O

## ■ 9.B. HOW TO MANAGE WATER CYCLES IN WATERSHED

### WATER FUNCTIONS IN THE ENVIRONMENT

Water is a fundamental component of all living organisms. It not only forms their internal medium enabling the chemical reactions regulating life but also secures the maintenance of definite cell shapes and the whole body - conditions for their proficient functioning.

Being a good solvent for many compounds, water leaches them when percolating through soils and non-soil materials (e.g., rocks), and then transfers them together with subsurface runoff to rivers or lakes. Insoluble materials can be transferred in the form of a suspension. No wonder that water being displaced in the landscape significantly influences the spread of various substances in the environment.

The ability of water to absorb large amounts of heat determines its significant role in temperature regulation of not only man's body, but also the environment surrounding him. Thus, for instance, evaporation of 1 litre of water, i.e., a 1 mm thick film of one square metre, absorbs as much energy as is necessary to heat a 33 m high air column by 60°C (Box 9.3).

#### BOX 9.3 Role of water in temperature regulation

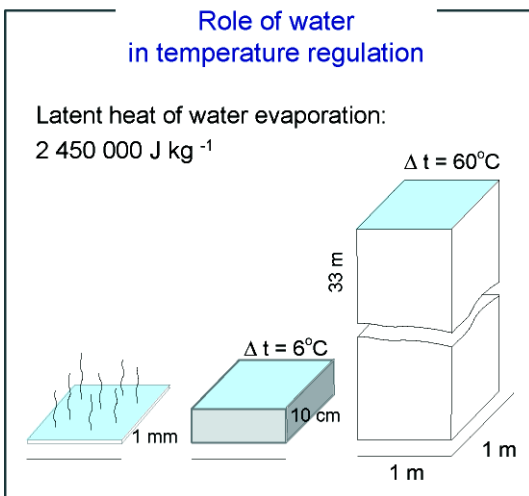

### HEAT AND WATER BALANCES

The balance between all fluxes of incoming and reflected radiation, as well as energy emitted by the active surface, defines the amount of energy intercepted by the landscape. The temporary state of this balance is called the net radiation (Rn)

and it determines the amount of energy used for the internal workings of ecosystems. The full equation for heat balance is:

$$R_n + G + LE + S + A + F + M + \dots = 0$$

where:

Rn - net radiation, G - soil heat, LE - latent heat, S - sensible heat, A - heat of advection, F - heat of biogeochemical processes, and M - heat stored by plant cover. All fluxes are expressed in W m<sup>-2</sup>.

The last two fluxes are very small in comparison with the others and so are omitted in calculations. Similarly, the water balance equation at a field scale and short period (one or a few days) is:

$$P + E + H_s + H_g + D + \Delta R_s + \Delta R_g + \Delta R_i = 0$$

where:

P - precipitation (positive), E - evapotranspiration (negative) or condensation (positive), H<sub>s</sub> - surface runoff (if surface inflow is higher than surface outflow, H<sub>s</sub> is positive, otherwise it is negative), H<sub>g</sub> - subsurface inflow or outflow (including lateral flow), D - percolation to ground water (negative) or capillary upward flow (positive), ΔR<sub>s</sub> - change of surface water retention, ΔR<sub>g</sub> - change of soil water retention, and ΔR<sub>i</sub> - change of plant cover water retention (change of interception).

Lengthening a time scale to a month or longer period one can neglect the change of plant cover retention, ΔR<sub>i</sub>. To increase the space scale to a catchment, the water balance equation can be expressed as:

$$P + E + H_s + H_g + \Delta R_s + \Delta R_g = 0$$

Increasing the time scale to a decade or more (if neither wetland formation nor desertification are observed) one can neglect the change of water retention and rewrite the equation as:

$$P + E + H = 0$$

Finally, for the earth's surface the water balance equation becomes:

$$P + E = 0$$

**BOX 9.4**

Balance of radiation (left part), heat balance (central part) and water balance (right part)

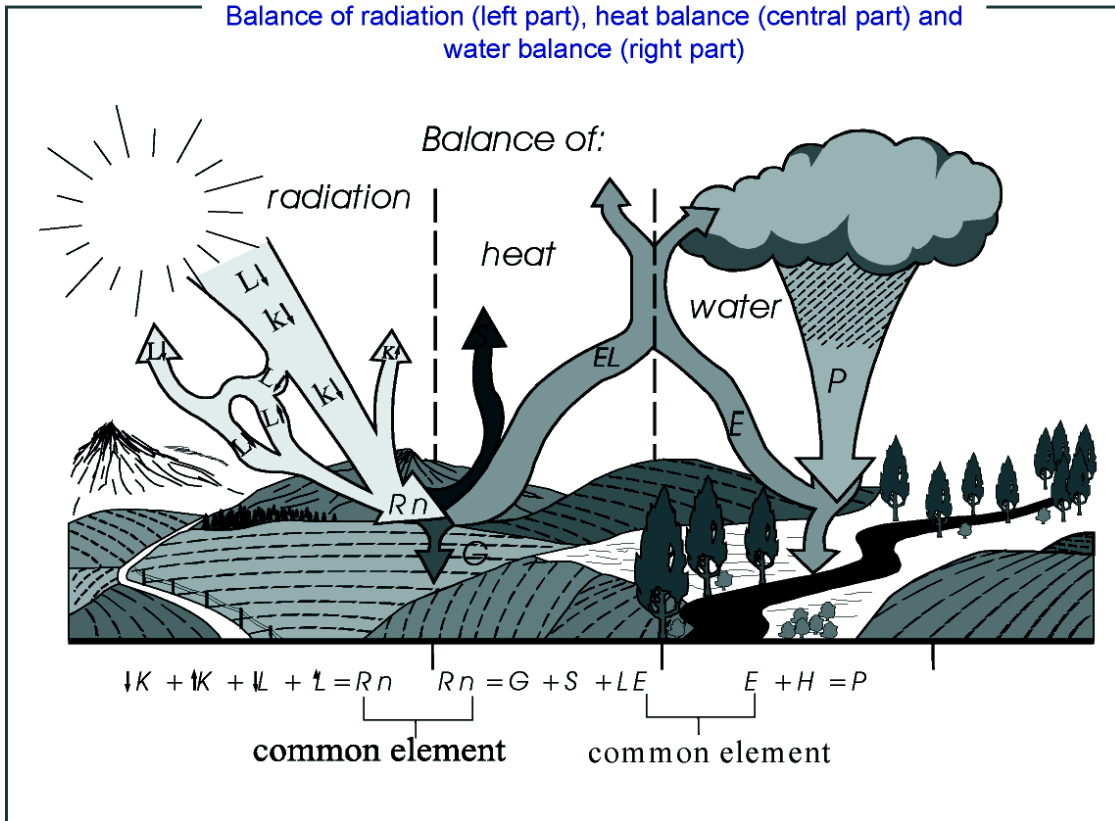

For the heat balance equation, as well as for the water balance equation, the fluxes entering a system are denoted as positive while outgoing ones are marked as negative.

These two balances are strongly coupled by the flux of latent heat in the heat balance and flux of water vapour in the water balance (Box 9.4).

**FACTORS DETERMINING WATER BALANCE STRUCTURE**

The structure of catchment water balance depends mainly on:

- ▶ an amount of **energy** available for evapotranspiration;
- ▶ variability and time distribution of **precipitation**; a parameter that is discrete in time and space;
- ▶ **physiographical** characteristics of a catchment (slope, denivelation, soil cover);
- ▶ density and type of **plant cover** and its development stage; and
- ▶ **land use**.

**HOW PLANT COVER INFLUENCES CATCHMENT PROCESSES**

Generalizing, it can be proved that plant cover within a catchment causes (Box 9.5):

- ▶ increased evapotranspiration;
- ▶ reduced surface runoffs, both due to increased infiltration to soil and evaporation;
- ▶ a slowing and increasing time extension of subsurface runoff from soils characterized by higher contents of humus (in underflows situated in ground covered by forest water flows all year round while ditches, situated among fields under cultivation, are dry in summer, even in a year of average precipitation); and
- ▶ modification of microclimatic conditions, as in the case of fields protected against wind by forests or shelterbelts where evapotranspiration is lower than in open spaces (Box 9.6).

**BOX 9.5**

Water balance structure of shelterbelts (left part of the upper picture),  
 crop field (right part of the upper picture) and  
 crop field located between shelterbelts (bottom picture)

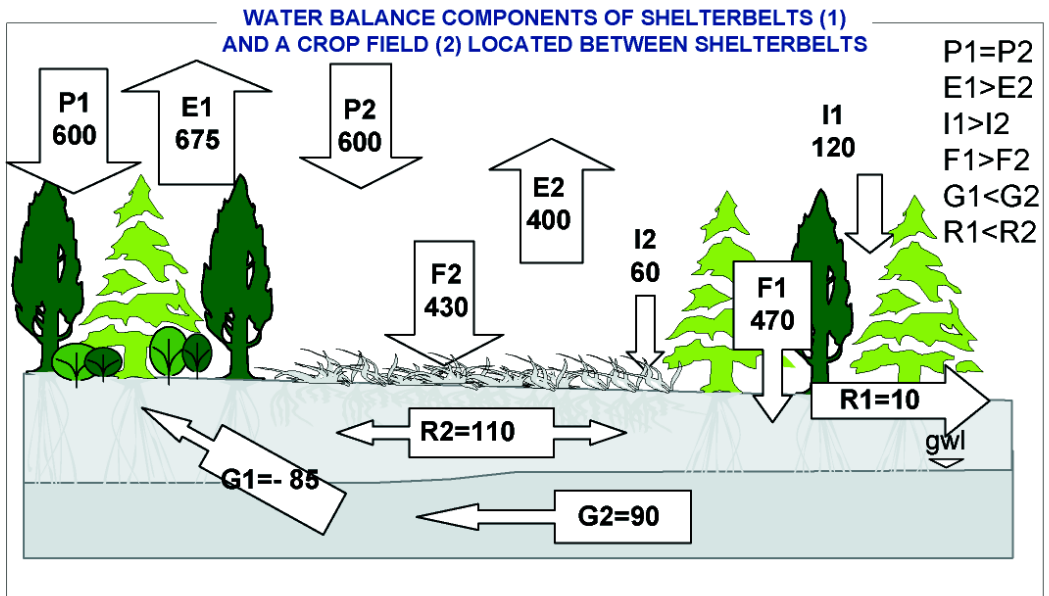
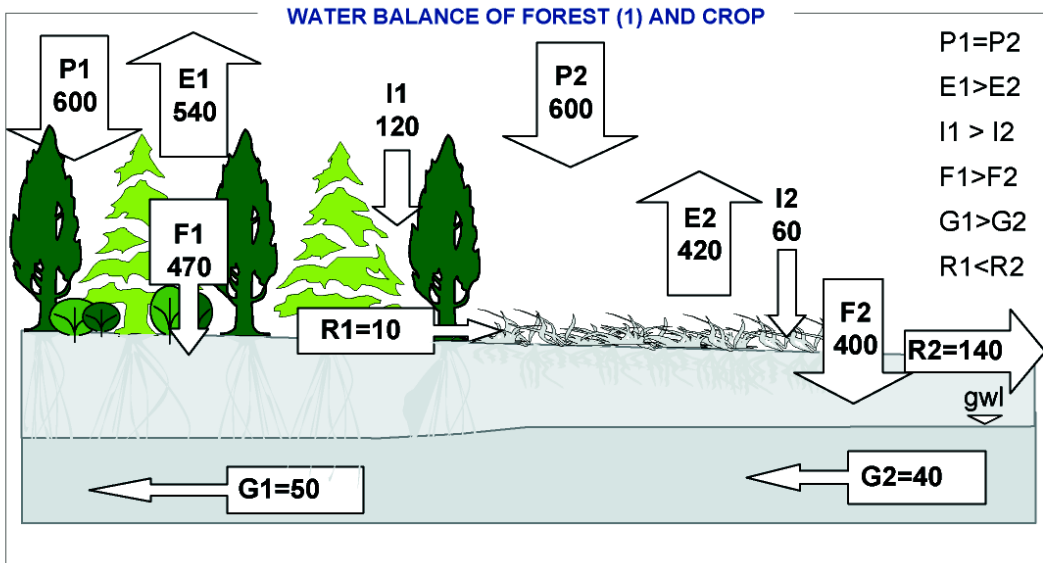

**P - precipitation      E - evapotranspiration      I - interception**  
**F - infiltration      R - surface runoff      G - subsurface flow**

$$P = I + F + R = E + G + R$$

$$E = F + I - G$$

## PRINCIPLES OF WATER DEFICIT CONTROL IN AGRICULTURAL CATCHMENTS

**Water shortage** is observed in many regions of the world where low precipitation and high evapotranspiration occur. Water deficits may often happen during the summer season, mainly because of the prevalence of light soils, low precipitation and very high atmospheric water demands. Table 9.2 shows an example of water shortage in the Wielkopolska region of Poland.

Proper water management in a landscape can improve these unfavourable conditions. It can be attained mainly through:

- ▶ **increasing small water retention** aided by artificial reservoirs storing excess thaw waters;
- ▶ **increasing soil retention**; and
- ▶ forming **plant cover structure**.

### Increase of small water retention

An increase of small water retention can be obtained mainly through:

- ▶ the exploitation of existing **small field water reservoirs**;
- ▶ reconstruction of **destroyed post-glacial ponds**;
- ▶ **interceptions of draining waters** at the time of their greatest runoff in **local depressions**; and
- ▶ introducing **swelling equipment** (gates) in the network of drainage ditches.

Small field reservoirs not only store water in their basins, but also increase **retention in the soil** surrounding the reservoir (Box 9.7). Increases of soil retention near small field reservoirs can be even higher than retention increases in the reservoir itself. Small water reservoirs contribute to the **rise of ground waters** in neighbouring areas, **increase the humidity** of soils and, subsequently, **decrease soil drifting**.

*The exploitation of small field reservoirs in the spring season can increase water availability of rural catchments by an amount equivalent to 20 mm of precipitation.*

### INCREASE OF SOIL WATER RETENTION

The best way for improving soil water retention is by **increasing the content of organic matter in the soil**. Soil organic matter plays an essential part in improving water conditions in agricultural landscapes. Organic matter increases soil retention because it retains more water than non-organic matter. Specifically this means an improvement of soil structure by increasing the average size pores, which determine the amount of water accessible for plants.

*In some cases, a 1% increase of organic matter increases water supply in a 30 cm ploughed layer by 10 mm or by 100 m<sup>3</sup> ha<sup>-1</sup>.*

**TABLE 9.2**  
Water shortage in Turew landscape (Poland) during the summer (April - September)

CLASS NUMBER	SOIL TEXTURE	UNIFORM WATERSHED				MOSAIC WATERSHED			
		normal	dry	v. dry	ex. dry	normal	dry	v. dry	ex. dry
1	Pl, pl.ps, pl:ps, ps.pl,	425	359	286	246	10	-56	-129	-169
2	ps, ps:pl, ps:gl	445	379	306	266	30	-36	-109	-149
3	ps.gl, pgl.gl, pgl:gl	485	419	346	306	70	4	-69	-109
4	pgm.gl, pgm:gl	525	459	386	346	110	44	-29	-69

*One dot between symbols (pl.ps) means thickness of upper layer equals 30 cm, and bottom layer 70 cm  
Two dots means inversely - upper layer thickness equals 70 cm but bottom layer 30 cm  
pl, ps, - sand, pgl - loamy sand, pgm - sandy loam, gl - loam*

### BOX 9.6

#### Impact of shelterbelts on alfalfa field water balance under advection

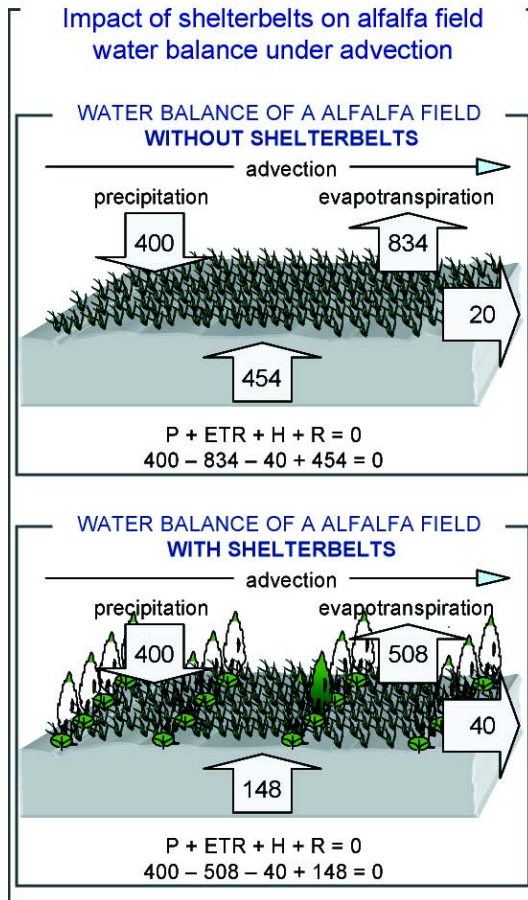

An increase of water retention by  $100 \text{ mm}^3 \text{ ha}^{-1}$  has significant economic meaning because the increase is not a single event but refers to each rain event, which can be accumulated in the soil. Thus, during a year, the amount of retention should increase several times.

If retention in a ploughed layer is repeated only three times during a year, the increase of soil water supply during a summer season will reach about 30 mm. This makes an essential saving, even without taking into account the improvement of soil moisture - thermal conditions favourable for vegetative growth and activity of microorganisms and soil fauna.

The proper structure of plant cover within agricultural landscapes exerts a strong positive effect on water cycling. The structure of plant cover, especially shelterbelts, plays a particular part in improving water conditions. They exert a favourable influence on the microclimate by **reducing**

wind speed by 35-40%, increasing **relative air humidity**, decreasing **potential evaporation**, increasing **snow depth**, and **reducing the melting rate of snow** in spring. When taken altogether, these increase the percolation rate by  $300 \text{ m}^3 \text{ ha}^{-1}$  in areas covered with shelterbelts compared to open areas (Box 9.7).

#### BASIC GUIDELINES FOR WATER MANAGEMENT IN A LANDSCAPE

Improvement of water cycling in the landscape requires:

- ▶ developing landscape complexity by introduction of shelterbelts, meadow strips and restoration of midfield ponds;
- ▶ increasing organic matter content in the soil;
- ▶ keeping as much water as possible in the landscape for as long as possible, taking care that it is properly allocated; and
- ▶ ensuring that as much water as possible moves from the soil into the atmosphere via plant transpiration, but not as evaporation from the soil to the atmosphere.

#### HOW TO DO IT

For this purpose:

- ▶ **unsystematic and partial draining** should be used more widely and every opportunity for retaining draining runoffs in a catchment area should be utilized;
- ▶ supplementary **to drainage retention, agromelioration measures** for improving the physical-water properties of soils and increasing their retention capacities and, consequently, decreasing water deficits for plants during the summer, should be widely applied;
- ▶ the scope of necessary agromelioration must take into account **negative interactions of farm work mechanization** for soil structure by condensing surface soil layers; and
- ▶ **proper landscape management** of catchments by optimizing arable land structure and adjustment of agricultural output to the natural resources of the environment, as well as introduction of shelterbelt networks, are fundamental conditions for increasing the effectiveness of water resource exploitation.



**BOX 9.7**  
**Water retention in midfield ponds and in soil surrounding a pond**

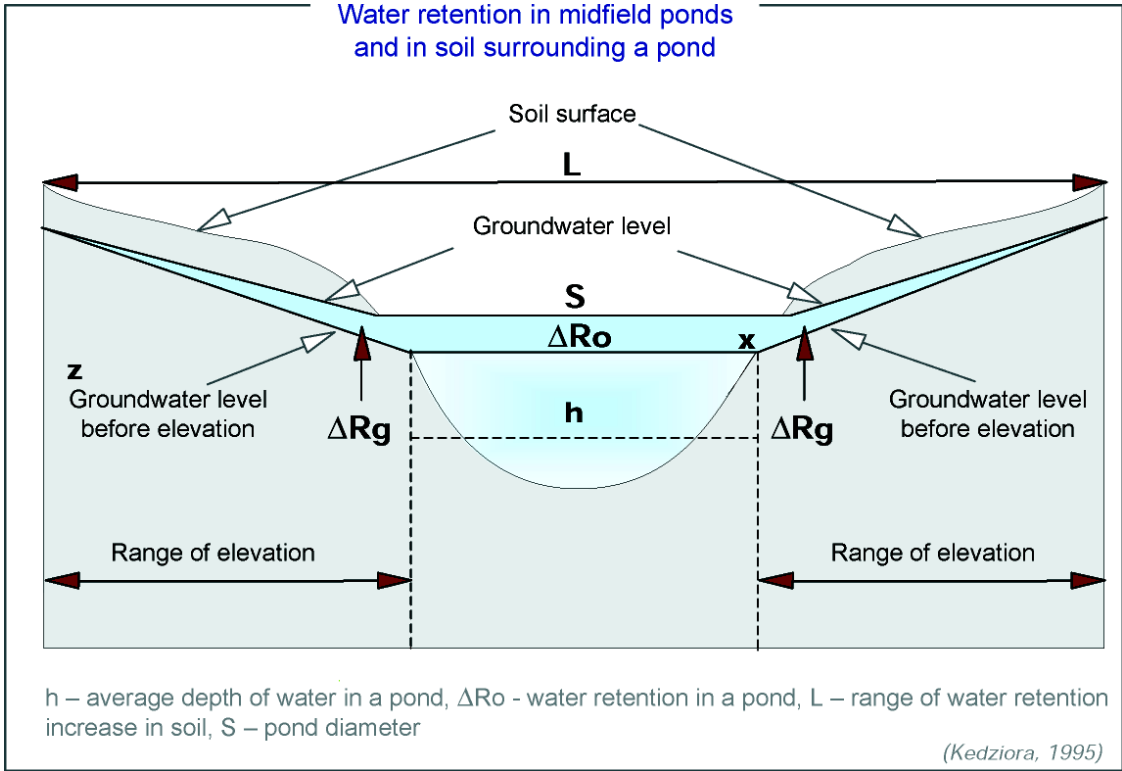

**BOX 9.8**  
**Impact of shelterbelt on microclimat of adjoining fields**

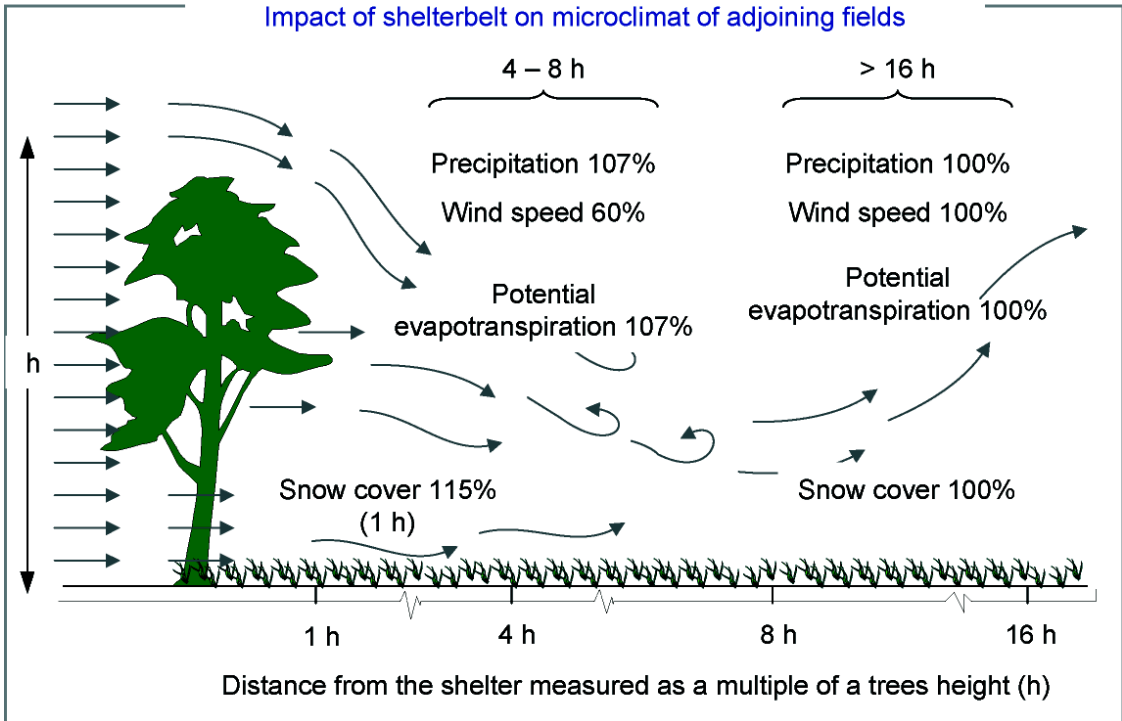

**MAKE SURE TO CHECK THESE RESOURCES:**

Guidelines: chapters 4.C, 4.E 4.J

## ■ 9.C. CONTROL OF DIFFUSE POLLUTANT INPUTS TO WATER BODIES

### ENVIRONMENTAL EFFECTS OF UNSUSTAINABLE AGRICULTURE

To increase production farmers simplify plant cover structure, both within cultivated fields (selection of genetically uniform cultivars and weed elimination) and within agricultural landscapes (elimination of hedges, stretches of meadows and wetlands, small mid-field ponds). Animal communities in cultivated fields are also impoverished (Ryszkowski, 1985; Karg & Ryszkowski, 1996). Farmers interfere with matter cycling in agroecosystems directly by inputs of fertilizers, pesticides, etc., or indirectly by changing water cycling and decreasing holding capacities of soils for chemical compounds. In addition, agricultural activity often leads to decreased humus contents. Increased use of power equipment enables not only deeper soil ploughing, but also land surface leveling, modification of water drainage systems, etc., which leads to changes in the geomorphological characteristics of the terrain. These effects of farming activity result in the development of a less complex network of interactions among agroecosystem components. Relationships between agroecosystem components are altered so that there is fewer tie-ups of local matter cycles. Thus, increased leaching, wind erosion, volatilization and escape of various chemical components and materials from agroecosystems have been observed (Ryszkowski, 1992, 1994).

#### How to reconcile agriculture activities and environmental protection

Many environmentally significant effects of agriculture intensification are connected with the impoverishment or simplification of agroecosystem structure. However, a farmer in order to obtain high yields must eliminate weeds, control herbivores and pathogens, insure that nutrients are easily accessible only for cultivated plants during their growth, increase mechanization efficiency, amongst other things. Therefore, agricultural activity aimed at higher and higher yields leads inevitably to the simplification of agroecosystem structure, which in turn causes further environmental hazards.



Fig. 9.5  
Diversified agricultural landscape  
(photo: I. Wagner Lotkowska)

Such an ecological analysis leads to a conclusion of major significance for the sustainable development of rural areas. Applying intensive means of production, farmers cannot prevent the threats to arable fields, as noted above, and these increase the risks of diffuse pollution to ground and surface waters, evolution of greenhouse gases ( $N_2O$ ,  $CO_2$ ) and water or wind erosion. It must be clearly said that although farmers can moderate the intensity of these processes through proper selection of crops and tillage technologies, they are not able to eliminate them entirely.

A higher control efficiency of environmental threats evoked by agriculture could be achieved by structuring agricultural landscapes with **various non-productive components** like, e.g.:

- ▶ hedges;
- ▶ shelterbelts;
- ▶ stretches of meadows;
- ▶ riparian vegetation strips; and
- ▶ small ponds.

Therefore, any activity to maintain or increase **landscape diversity** is important not only for aesthetics and recreational reasons, but even more so for environment protection and for the protection of living resources in the countryside.

#### EFFECTIVENESS OF VEGETATION BUFFER ZONES FOR CONTROLLING DIFFUSE POLLUTION

Recent developments in agroecology and, especially in studies on agroecosystems and rural landscape functions like solar energy flows, matter cycling, and maintenance of biodiversity, help to

tackle the problems of environmental threats. Studies on impacts of plant cover patterns on agricultural landscape functions are especially relevant in this respect.

There is an increasing amount of evidence that **permanent vegetation strips can control the dispersion of chemical compounds leached out of cultivated fields** (see recent published proceedings of conference on buffer zones edited by Haycock et al., 1997). To describe the effectiveness of buffer zones for controlling diffuse pollution, the results of studies carried out by the Research Centre for Agricultural and Forest Environment in Poznan, Poland will be presented.

### Reduction of chemical compounds in ground waters

Nitrate concentrations in ground water from beneath meadows and shelterbelts studied in the Wielkopolska region (Poland) were significantly lower than those in ground water under adjoining fields. In some areas the reduction in the mean nitrate concentrations in ground water under the biogeochemical barrier (shelterbelt) was 34 fold (from 37.6 mg L<sup>-1</sup> to 1.1 mg L<sup>-1</sup>; Bartoszewicz & Ryszkowski, 1996). But usually the decrease in nitrate concentrations under the biogeochemical barrier was lower, in the range of 10-20 fold. In

ground water under some cultivated fields very high concentrations of nitrates, reaching 50 mg NO<sub>3</sub>-N per litre, were detected, while in the stream draining this watershed the average concentration of NO<sub>3</sub>-N over many years did not exceed 1.5 mg NO<sub>3</sub>-N per litre (Table 9.3). The stream is separated from fields by stretches of meadows, hedges, and shelterbelts. Thus, the strong controlling effect of these biogeochemical barriers can be observed (Bartoszewicz, 1994; Ryszkowski et al, 1997). The decrease of phosphate concentrations in ground water under the fields and biogeochemical barriers was less striking; usually the concentration decrease was 10-50 percent.

*Concentrations of many chemical compounds migrating from the ground in outflows from neighbouring cultivated fields are seriously reduced when the water passes under such biogeochemical barriers as shelterbelts, mid-field forests and riparian vegetation strips (Box 9.9).*

### Prevention of compound export from landscapes to waters.

The great influence of plant cover structure on the output of elements from watersheds was shown by Bartoszewicz (1994) and Bartoszewicz & Ryszkowski (1996). The studies were carried out in two

**TABLE 9.3**  
Mean concentrations of NO<sub>3</sub>-N (mg dm<sup>-3</sup>) in ground water under cultivated fields, shelterbelts, small forests and meadows in the Turew agricultural landscape, Poland

Period of sampling	Cultivated field (a)	Shelterbelt or forest	Meadow (b)	Reduction (a-b):a (percent)	Reference
1982-1986	22,2	1,0	-	95	Bartoszewicz & Ryszkowski, 1996
1982-1986	37,6	1,1	-	97	Bartoszewicz & Ryszkowski, 1996
1972-1973	12,6	0,3	-	98	Margowski & Bartoszewicz, 1976
1984-1986	33,1	8,1	-	75	Ryszkowski et al., 1997
1994	52,4	2,7	-	94	Ryszkowski et al., 1997
1995	13,1	4,9	-	63	Ryszkowski et al., 1996
1986-1989	48,3	-	6,5	87	Bartoszewicz, 1990
1987-1989	15,9	-	0,7	95	Bartoszewicz, 1990
1987-1991	13,1	-	2,8	79	Szpakowska & Zyczynska-Baloniak, 1994
1993	18,7	-	1,4	92	Ryszkowski et al., 1996
1993	22,1	-	2,0	91	Ryszkowski et al., 1996
1994	19,1	-	1,2	94	Ryszkowski et al., 1996
1994	13,4	-	2,4	82	Ryszkowski et al., 1996
1995	18,3	-	0,6	97	Ryszkowski et al., 1996

**BOX 9.9**

**Function of shelterbelts in purification of groundwater pollution**

The studies carried out in Wielkopolska region with sandy soils showed the efficiency of **purification for nitrates in range of 65 – 97%**

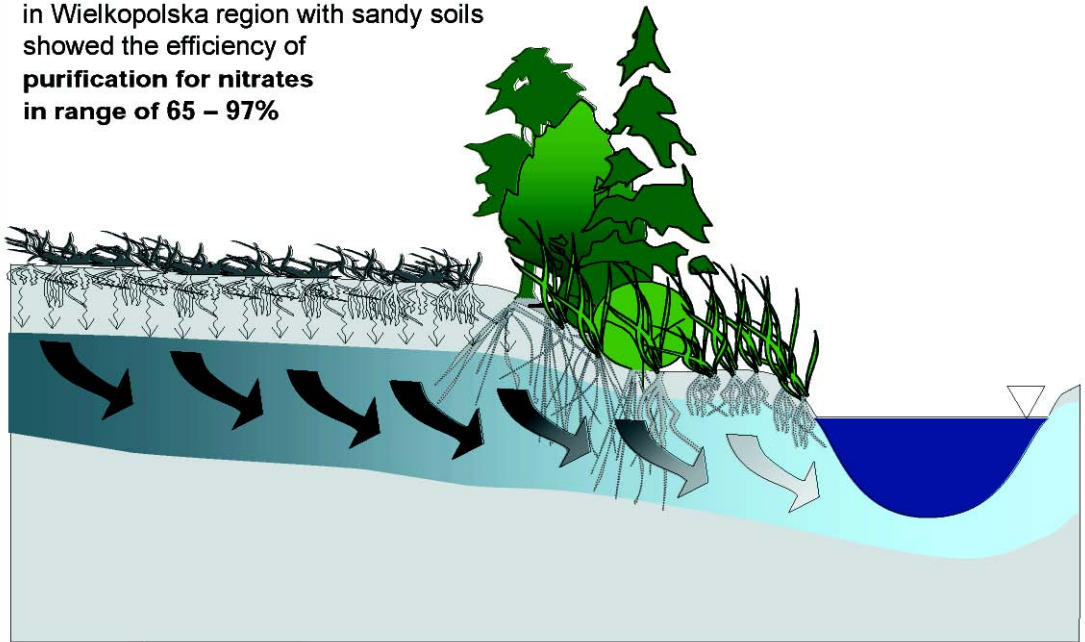

gradient of concentration of chemical compounds dissolved in ground water

small watersheds. The first one, called a uniform watershed, was 99% composed of cultivated fields and 1% small forests. In the second one, called a mosaic watershed, cultivated fields made up 70% of the area, meadows 14% and riparian forest 16%. The mean annual water output from the mosaic watershed during a 3 year period was 70.2 mm<sup>2</sup> and in the uniform one, 102.0 mm<sup>2</sup>. The mean annual precipitation for both watersheds was the same; 514 mm<sup>2</sup> (Table 9.4).

From an uniform arable watershed, 20.4 kg of inorganic nitrogen leached from 1 ha annually, 20% of which was in the form of ammonium ions.

When the migration of mineral components from a mosaic watershed was analysed, a low leaching rate of nitrogen constituents and different ratio of nitrate to ammonia ions were observed. The annual leaching rates of N from 1 ha of this watershed amounted to about 2 kg (ten times less than in the uniform watershed), and both ionic forms of N were represented in almost identical propor-

tions. Even more striking were the differences between the uniform arable watershed and the mosaic one with respect to seasonal variations in the migration of nitrogen. The majority of both nitrogen ion forms (86%) had leached from the mosaic watershed during winter, while during the summer period, the leaching of both nitrogen forms (particularly nitrate) was negligible.

**Enhancement of resistance to degradation**

Naturally compatible structures that assist in controlling matter cycles in agricultural landscapes are of great importance for **enhancing a countryside's resistance to degradation**.

Various plant cover structures like hedges, shelterbelts, stretches of meadows and riparian vegetation strips are of special interest. Application of these structures has several benefits, of which the most important are:

- ▶ they can be easily planted;
- ▶ they are not expensive and could provide

**TABLE 9.4**  
Annual mean water output (mm) and nutrient loss ( $\text{g m}^{-2} \text{ year}^{-1}$ )  
from two small watersheds in Poland, from November 1988 – October 1991

SEASON	Precipitation (mm)	UNIFORM WATERSHED			MOSAIC WATERSHED		
		Water output (mm)	NO <sub>3</sub> -N	NH <sub>4</sub> -N	Water output (mm)	NO <sub>3</sub> -N	NH <sub>4</sub> -N
<b>Winter season</b> Nov.-April	220,7	60,8	12,3	3,0	56,8	0,90	0,95
<b>Summer season</b> May-Oct.	292,9	41,2	4,0	1,1	13,4	0,05	0,25
<b>Whole year</b>	513,6	102,0	16,3	4,1	70,2	0,95	1,20

(Bartoszewicz, 1994)

economic benefits (e.g., timber, herbs, honey etc.);

- ▶ they can fulfil some societal needs (hunting, photography, mushroom and berry picking, etc.); and
- ▶ they are very important from the point of view of ecological engineering, because biogeochemical barriers exert controlling effects on non-point pollution.

#### Mid-field water reservoirs

Mid-field water reservoirs also intercept chemical substances, immobilizing them in bottom de-

posits where they are subjected to transformation by biogeochemical processes.

The role of small mid-field ponds, lately neglected and often treated as wastelands, is particularly significant for more efficient use of fertilizers. They may serve as a tool for modification of matter cycling because the chemical compounds leached from fields could be returned to arable fields with sediment. Such forms of field fertilization were applied in the past on a fairly wide scale, as was described by General Dezydery Chlapowski in his book on agriculture published in 1843.

#### MAKE SURE TO CHECK THESE RESOURCES:

Guidelines: chapters 4.E, 5.B-5.G

## ■ 10.A. CONSTRUCTED WETLANDS: HOW TO COMBINE SEWAGE TREATMENT WITH PHYTOTECHNOLOGY

Operation of constructed wetlands is based on a detailed understanding of ecohydrological processes in different types of natural wetland systems. In the purification of sewage/water, both abiotic and biotic processes are involved. By employing evolutionary established regulation processes (see „green feedback concept“, Zalewski et al., 2003) it is possible to optimize these systems. For planning high efficiency or long-term use of wetlands, these systems need additional management such as plant harvesting, fishing, and sediment removal.



Fig. 10.1  
Constructed wetland for storm water  
Karls-Einbau Project Company  
(photo: EKON Polska Biologia Inżynieryjna Sp. z o.o.)

### WHEN TO APPLY CONSTRUCTED WETLANDS

Constructed wetland can be applied to:

- ▶ treatment of **sewage from small settlements**;
- ▶ treatment of **municipal and industrial sewage**;
- ▶ **storm water** treatment (Fig. 10.1);
- ▶ purification of outflow from a sewage treatment plant for stabilization, reduction of nutrients, reduction of microbial and other pathogens;
- ▶ treatment of **surface runoff from arable land** (Fig. 10.2); and
- ▶ for use as a clean-up process in closed water cycles for industry or for water reuse.

The key challenge for the ecohydrology concept is converting potential threats, e.g., water pollutants, into opportunities such as energy sources. This new challenge of sustainable development can be achieved by combining water purification systems with the production of biomass in constructed wetlands, which can be utilized as bioenergy for local communities and provide them with economic profits (Box 2.8).

### WHAT ARE THE ADVANTAGES OF USING CONSTRUCTED WETLANDS?

- ▶ they utilize solar energy driven purification processes;
- ▶ the establishment of a constructed wetland is rather simple compared to building a sewage treatment plant (there is no need for specific building equipment);
- ▶ if available land is not a limitation, the longevity of large systems is calculated to be 50 - 100 years;

- ▶ properly designed, they are self-sustaining systems;
- ▶ because constructed wetlands are very productive systems, it is possible to combine wetlands with economic profits for local communities using proper phytotechnologies (fast growing plants: willows, reeds, or other native species for a region); and
- ▶ combining constructed wetlands with specific phytotechnologies, like phytoextraction or rizodegradation, can solve specific water pollution problems such as heavy metals and organic compounds.

### WHAT PROBLEMS CAN BE SOLVED BY CONSTRUCTED WETLANDS?

The following processes take part in constructed wetlands and solve respective environmental problems (see Guidelines Chapter 5):

- ▶ **denitrification** whereby nitrate is denitrified under anaerobic conditions in a wetland and organic matter accumulated in the wetland provides a carbon source for microorganisms converting nitrate to gaseous nitrogen - oxygen conditions can be regulated by water flow rates;
- ▶ **adsorption of ammonium and metal ions by clay minerals** - the adsorption process can be regulated by addition of various minerals during the filter design,
- ▶ **adsorption of metal ions, pesticides, and phosphorus compounds** by organic matter, and

the complexing of metal ions by humic acids and other organic polymers, which significantly reduces the toxicity of these ions - stimulation of humus-forming processes;

- ▶ **decomposition of biodegradable organic matter**, either aerobically or anaerobically, by microorganisms in the transition zone - creation of proper microhabitats;
- ▶ **removal of pathogens** that are out-competed by natural microorganisms within the transition zone; UV radiation plays an important role;
- ▶ **uptake of heavy metals and other toxic substances** by macrophytes to varying degrees of efficiency; proper selection of plants and regulation of oxygen conditions using the water regime;
- ▶ **decomposition of toxic organic compounds** through anaerobic processes in wetlands, which depends upon the biodegradability of the compounds and their retention time in a wetland;
- ▶ for regions with **eutrophication problems**, the use of additional materials with high concentrations of magnesium, calcium, iron, and/or aluminum, increases phosphorus sorption; and



Fig. 10.2  
Constructed wetland for surface runoff from arable land, Japan  
(photo: V. Santiago-Fandino)

- ▶ enhancement of **sedimentation** of TSS in wetlands for storm water treatment by using a sequence of different plants.

### HOW TO DESIGN A WETLAND

#### Preliminary criteria

To **optimize the efficiency** of a constructed wetland, all possible potential processes should be carefully quantified at the design stage.

**The following aspects should be taken into account:** region, climate, key contaminants, main purpose, health aspects (e.g., pathogens, malaria).

Examples of **typical constructed wetlands** are demonstrated in Box 10.1. In order to enhance the efficiency

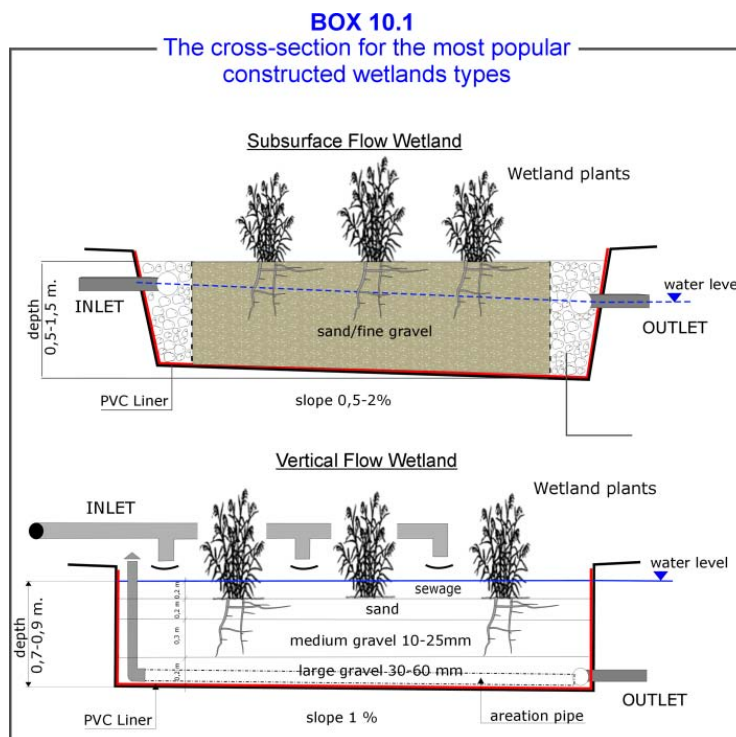

of purification, newly constructed systems comprise of sequential systems, with several - sometimes more than 5 - stages of purification. For example, in a typical system the following stages can be applied:

- ▶ horizontal subsurface flow;
- ▶ vertical flow; and
- ▶ stabilization pond(s).

The combination of various wetland systems increases the efficiency of BOD and nutrient removal, even up to more than 90%.

The **preliminary criteria** to be considered in order to construct a properly planned wetland should include:

- ▶ **type of outflow** to be controlled, e.g., need for preliminary treatment or use of a multi-functional system combining different types of constructions;
- ▶ **hydrogeological** characteristics of a site;
- ▶ surrounding **landscapes** provide the conditions for one of the following wetland types:
  - overland flow;
  - surface flow;
  - subsurface flow; and
  - ponds.
- ▶ **available space** and the price of land;

- ▶ **possible additional economic profits** for local communities;
- ▶ the **cost** decrease for treating sewage.

**Plants to be used in wetlands**

Use of native species is recommended in wetlands. For this purpose, recognition of vegetation communities in natural wetlands and land/water ecotones is recommended. The following plant types can be used:

- ▶ **emergent species:** cattails, bulrushes, reeds, rushes, papyrus, sedges, manna grass and wil-lows;
- ▶ **submerged species:** coontail or horn wart, redhead grass, widgeon grass, wild celery, Elodea, and water milfoil; and
- ▶ **floating plants:** duckweed, water meal, bog mats and water hyacinth.

**Specific criteria**

The following specific criteria will influence the efficacy of wetlands:

- ▶ **hydrology and size:**
  - water retention time;
  - hydraulic conductivity;
  - water depth; and
  - length to width ratio.

**TABLE 10.1**  
Summarized design criteria for constructed wetlands

	UNIT	OVERLAND FLOW	SURFACE FLOW	SUBSURFACE FLOW	PONDS	PONDS FOR STORM WATER
<b>Need for preliminary treatment</b>	-	Preliminary or secondary	Preliminary or secondary	Preliminary or secondary	Preliminary or secondary	sedimentation area
<b>Specific treatment area</b>	Ha 1000 m <sup>-3</sup> day <sup>-1</sup>	6-67	0,8-12	0,25-3,5	0,2-1,5	not applicable
<b>Specific treatment area</b>	m <sup>2</sup> PE	10-25	3-25	1-10	2-5	
<b>Hydraulic loading rate</b>	cm day <sup>-1</sup>	1-10	0,5 -12	3-40	5-20	
<b>Detention Time</b>	days		7-10	2 - 15	0,5 - 14	0,1-5
<b>Average Water depth</b>	m	<0,1	0,1-0,5	0,5-2 depth of filter	1,5 - 4	0,5-1,5
<b>Length to width ratio</b>	-	5:1	2:1	6:1	1:1	15:1

PE – person equivalent

*Preliminary treatment – the first step in sewage treatment consists of screening and sedimentation of particulate solids. Secondary treatment – wastewater treatment beyond initial sedimentation; the second step of treatment includes biological reduction of particulate and dissolved compound concentrations.*

(Vymazal et. al, 1998; Kadlec & Knight, 1995)



- ▶ **wetland soil:**
  - organic content;
  - clay content; and
  - soil water capacity.
- ▶ **contaminant concentration:**
  - presence of heavy metals (application of specific phytotechnologies is recommended; see chapter 9.A);
  - organic compounds - phytodegradation;
  - N - denitrification;
  - BOD;
  - TSS; and
  - P - use of additional materials for sorption.

The design criteria are summarized in Table 10.1.

### HARMONISATION OF TECHNOLOGIES AND ECOLOGICAL METHODS

There are several advantages of the harmonization of technologies with ecohydrology and phytotechnology

application in sewage purification. The following can be listed among the most important ones:

- ▶ increase of the efficiency of pollutants removal (in case of nutrients it reach even more than 90%);
- ▶ decrease of investments for sewage treatment systems;
- ▶ decrease of operational costs of treatment systems;
- ▶ stabilizing hydrological cycles in a local scale;
- ▶ converting pollutants into renewable energy resources;
- ▶ decrease of waste (sludge) production; and
- ▶ creating of employment opportunities.

The example of the approach to combining technical and ecological solutions is given on the simplified schemes in the Box 10.2.

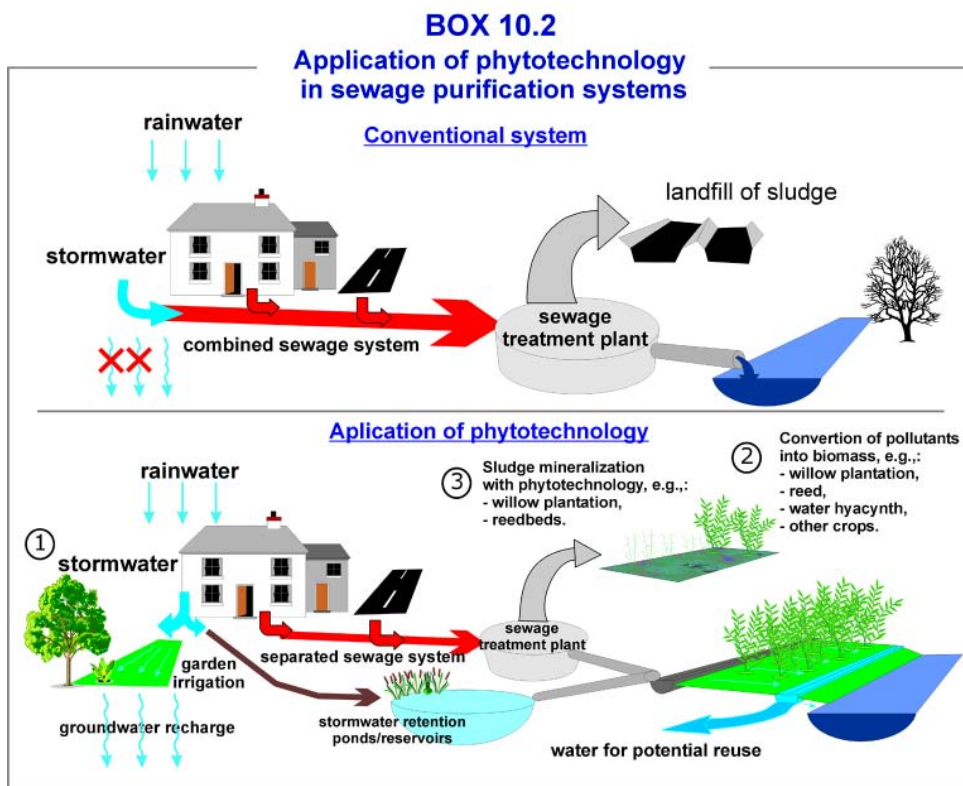

#### MAKE SURE TO CHECK THESE RESOURCES:

Guidelines: chapters 5.H-5.Q, 7.A

Mitsch & Jorgensen 2004

<http://www.gpa.unep.org/documents/sewage-docs.htm>

<http://www.cep.unep.org/pubs/techreports/tr43en/Small%20community.htm>

<http://www.epa.gov/owow/wetlands/construc/content.html>

<http://www.waterrecycling.com/constwetlands.htm>

## ■ 10.B. ECOTONES: HOW TO DIMINISH NUTRIENT TRANSPORT FROM LANDSCAPES

One premise of the ecohydrological approach is the enhancement of ecosystem resilience in order to protect it from disturbance. At the landscape scale, resilience is a function of the area occupied by biogeochemical barriers that create nutrient storage. From the point of view of freshwater quality improvement, land-water ecotones are one of the most important biogeochemical barriers in a landscape. This chapter introduces basic methods related to use of natural properties of terrestrial and freshwater ecosystems toward reducing nutrient exports to fresh waters.



Fig. 10.3  
An example of a natural ecotone zone  
(photo: K. Krauze)

### HOW TO DESIGN AND CONSTRUCT A BUFFERING ZONE

Plant buffering zones may have natural or artificial origins. For ecological, economic and aesthetic reasons it is recommended to preserve or enhance natural ecotone zones rather than build artificial ones.

In some areas, however, due to lack of natural buffering zones or high pollution loads, it may be necessary to create artificial buffering zones or to modify existing ones.

There are several factors that have to be considered before preparation of an action plan:

- ▶ the geomorphology of the area;
- ▶ hydrological dynamics, e.g., water level fluctuations, timing and the range of extreme events;
- ▶ plant species composition in natural land / water ecotones in the area;
- ▶ species - specific efficiency of nutrient removal, growth rate, decomposition;
- ▶ interactions between plant species; and
- ▶ planned use of an area (for recreation, agriculture, etc., see Box 10.4).

#### Geomorphology

It has been shown that incline is an important factor determining the rate of nutrient reduction in buffering zones. Muscutt (1993) demonstrated that for plant strips with a width of 4,6 m located on an incline of 11%, a 73% reduction of total phosphorus transport to a water body could be achieved. The efficiency was only 49% when the incline was 16%. Similarly for wider strips (9 m), the re-

duction rates were 93% with an incline of 11% and 56% with a 16% incline.

It is also highly recommended to reduce the bank slope, if possible, before building an ecotone. This will reduce the risk of bank erosion and, therefore, transport of matter into the water (Petersen et al., 1992). Moreover, the widening of a river channel will enhance the process of wetland development and help to disperse the energy of peak flows. Finally, a larger floodplain is conducive to sedimentation processes.

#### Species composition

It has to be underlined that artificial and modified buffering zones should reflect the natural biodiversity (use of alien species should be avoided), zonation and patchiness of vegetation in an area if they are to be efficient.

#### Trees

Tree species are elements of buffering zones that are able to store nutrients for longer times and do not require time-consuming conservation. They also regulate the dynamics of herbs, grasses and shrubs (Boyt et al., 1977).

They should be distributed in an irregular way and at a distance of 4-5 m from one another. To avoid linear patterns, which are unusual in nature, it is also recommended to use different tree species, with different heights and to leave some gaps between trees.

Species that strongly shade the ground should be used carefully (oaks, beech, conifers) and plan-

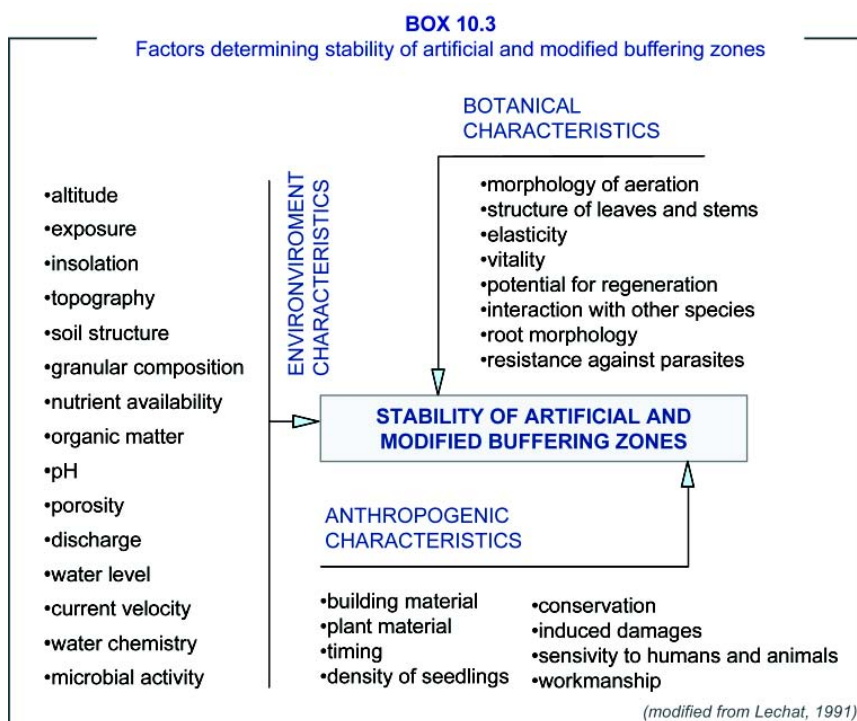

ted with other species like birch, willow, rowan tree, ash or hazel.

### Shrubs

The most popular shrubs used in buffering zones are willows. Different species of willow provide a broad range of possibilities as they have species-specific adaptations to water level, nutrient concentrations, and different rates of nutrient accumulation and distribution of accumulated contaminants among plant organs.

Efficiency of nutrient uptake by willow strips may be enhanced by cutting furrows in the ground (as it increases water retention in ecotones).

### Grasses

Grasses are highly applicable in infrequently flooded areas. They are not as efficient in nutrient uptake as other plant species, but they may play important roles in reduction of bank erosion.

Grasslands require very intense care and conservation as species composition changes easily due to disturbances (increased nutrient supply, prolonged flooding, etc.).

The choice of grass species should be made on the basis of the following rules:

- ▶ the most resistant are species that form deep roots;
- ▶ to enhance biomass production it is necessary to use a diverse grass composition; and
- ▶ as grasses are used to fasten soil on banks and scarps, it is important to use them with poor, sandy soils on slopes distant from water and with fertile soils on a riverside.

**TABLE 10.2**  
The rate of biomass increase of some wetland species

SPECIES	INCREASE OF BIOMASS (kg ha <sup>-1</sup> year <sup>-1</sup> )
<i>Typha</i>	8 000 - 61 000
<i>Juncus</i>	53 300
<i>Scirpus</i>	7 130
<i>Phragmites</i>	10 000 - 60 000
<i>Hydrocotyle</i>	30 000 - 60 000
<i>Lemna minor</i>	6 000 - 26 000
<i>Salvinia</i>	9 000 - 45 000

(modified from Reddy, DeBusk, 1987)

**Macrophytes**

The most popular species of macrophytes are emergent ones, like reeds. They are valuable in building biochemical barriers because they not only accumulate nutrients, which can be easily removed after plant harvesting, but some of them are able to oxygenate sediments (e.g., *Phragmites*, *Typha*). In this way they enhance development of microorganisms and increase oxidation process rates.

**TABLE 10.3 (A)**  
Phosphorus and nitrogen assimilation by macrophytes

Phosphorus and nitrogen accumulation by different macrophyte species		
SPECIES	N uptake [kg ha <sup>-1</sup> year <sup>-1</sup> ]	P uptake [kg ha <sup>-1</sup> year <sup>-1</sup> ]
<i>Typha</i>	600 - 2 630	75 - 403
<i>Juncus</i>	800	110
<i>Scirpus</i>	125	18
<i>Phragmites</i>	225	35
<i>Hydrocotyle</i>	540 - 3 200	130 - 770
<i>Lemna minor</i>	350 - 1 200	116 - 450
<i>Salvinia</i>	350 - 1 700	92 - 450

(Kadlec & Knight, 1996 after Reddy & DeBusk, 1991)

There are several factors which one should consider when planning to use macrophytes in ecotone zones. The most important are:

- ▶ growth rate;
- ▶ nutrient uptake and accumulation rate;
- ▶ hydroperiod ; and
- ▶ decomposition rate (Tables 10.2-10.4).

**In general**

There are several components which are used in constructing wetlands along rivers and reservoir shores. The most common are:

- ▶ sedimentation ponds;
- ▶ by-passes;
- ▶ ditches for surface flow collection;
- ▶ willow zones;
- ▶ tree and shrub zones;
- ▶ floating macrophytes zones;
- ▶ submerged macrophytes zones; and
- ▶ embankments, etc.

Their sequence has to be planned according to local requirements (Box 10.4).

**TABLE 10.3 (B)**  
Phosphorus and nitrogen assimilation by macrophytes

Percentage phosphorus and nitrogen accumulation by different macrophyte species		
SPECIES	N uptake [% of dry weight]	P uptake [% of dry weight]
<i>Bidens</i> sp.	no data	0,582
<i>Mentha aquatica</i>	no data	0,584
<i>Typha latifolia</i>	1,37	0,21
<i>Typha laugustifolia</i>	0,8-22,9	0,1-0,5
<i>Phragmites communis</i>	2,57	0,18
<i>Glyceria maxima</i>	0,4-4,6	0,1-0,8
<i>Juncus effusus</i>	1,24	0,27
<i>Scirpus</i> sp.	1,22	0,18
<i>Acorus calamus</i>	1,3-3,7	0,1-0,9
<i>Schoeplecyus lacustirs</i>	0,6-2,6	0,1-0,5
<i>Sagittaria</i>	no data	0,827
<i>Nuphar luteum</i>	no data	6,2
<i>Lemna</i> sp.	1,5-7,2	0,6-2,8
<i>Ceratophyllum demestrum</i>	1,8-4,5	0,1-0,8
<i>Elodea candensis</i>	1,8-7,7	0,1-1,4
<i>Myriophyllum spicantum</i>	1,4-4,1	0,1-0,7

(Bazan, 1998; Kadlec, Knight, 1995 after Boyd, 1978; Reddy, Ozimek, 1991; DeBusk, 1987)

**TROUBLESHOOTING**

**There is little or no influence of ecotones on the chemistry of waters**

Sometimes it may happen that plant communities do not influence the chemistry of ground water passing an ecotone. One of the common reasons is the geological structure of the area. Due to the arrangement of different water permeability layers, pollution may, **instead of passing a plant root zone, go with ground water directly to the river, or reservoir.** The only way of avoiding this problem is to know the geology of the region and distribution of point and non-point sources of pollution.

**Buffering zones release nutrients**

There are three common reasons for this phenomenon:

1. Biogens are stored in plant biomass and soil structures. Prolonged nutrient inflow to a buffering zone may occasionally cause a decline of bio-

diversity and, therefore, reduction of biomass production. It may also lead to saturation of soil and ground structures. In these cases, an ecotone is no longer effective as a biofilter and starts to release nutrients.

For these reasons it is very important **properly plan, monitor and manage buffering zones**.

2. The ability of ecotones to reduce nutrient concentrations in water changes seasonally, and depends on species composition, species phenology, growth rate, etc. Nutrients that were accumulated during the growing season are released at its end due to an increase in litter production and decomposition. The process maybe controlled and reduced by using **plant** species, which are easy to **maintain, cut and remove**.

In temperate regions the growing season starts when water temperature reaches 7°C and ends when it drops below 10°C (Bernatowicz & Wolny, 1974). Reeds have the longest life cycle but submerged macrophytes are often active throughout the year.

3. Exceeding the threshold tolerance of plant species to concentrate nutrients causes plant buffering zones to degrade. The process has been well documented for submerged macrophytes, e.g., for *Elodea canadensis* and *Elodea nuttali* - the critical concentration of nitrogen in water is 4 mg L<sup>-1</sup> (Ozimek et al., 1993).

#### Vegetative season end

Even after the end of a growing season there are still processes that may improve water quality.

It was found that the denitrification rate is low, but stable even when air temperatures drops below 5°C. This is possible because the ground water temperature is usually higher, and stays stable during winter.

High efficiency of ecotones is also maintained if seasonal plant harvesting is carried out. It prevents secondary nutrient release after plants decompose and retains the whole system at an early succession stage, which is more effective for nutrient uptake. For management purposes it is better to use species that accumulate nutrients in leaves and stems instead of in roots.

**TABLE 10.4**  
Tolerance of some typical land/water ecotone species to hydrological conditions

In land/ water ecotones water plays an especially important role. It may support plant development, but can also stop it leading to degradation of ecotone functions. Therefore, one of the factors, that has to be considered is the hydroperiod. It is defined by the time when the community is flooded and the depth of the water covering plants (Gunderson, 1989).		
SPECIES	maximum tolerable water depth [m]	Time of flooding [%]
<i>Fontinalis</i>	0,1 - 1,5	80 -100
<i>Elodea</i>	0,1 - 3,0	90 -100
<i>Myriophyllum</i>	0,25 - 3,0	90 -100
<i>Nuphar</i>	0,5 - 3,0	90 -100
<i>Hydrocotyle</i>	<0,005 - 1,0	25 -100
<i>Salix</i>	0,1 - 0,5	50 -100
<i>Sagittaria</i>	0,2 - 0,5	50 -100
<i>Carex</i>	0,05 -0,25	50 -100
<i>Scirpus</i>	0,1 - 1,5	75 -100
<i>Phragmites</i>	<0,05 - 0,5	70 -100
<i>Iris</i>	<0,05 - 0,2	50 -100
<i>Juncus</i>	<0,05 - 0,25	50 -100
<i>Typha</i>	0,1 - 0,75	70 -100
<i>Glyceria</i>	<0,05 - 0,3	0 -100

(modified from Kadlec & Knight, 1996)

#### CONCLUDING REMARKS

The use of ecotones as a tool for water and environmental quality improvement is concordant with the ecohydrological approach. Buffering zones enhance natural resilience of water ecosystems against human impacts, are easily applicable, have good cost/benefit ratios, and may provide additional sources of income for local communities. It is, however, highly advised to combine protection of water resources with riparian zones and large scale landscape planning. The aim has to be a counterbalancing of the impacts of human activity at a catchment scale. According to Mander & Palang (1996) this has to be hierarchically organized, and include:

- ▶ core areas;
- ▶ buffer zones of core areas and corridors; and
- ▶ natural development areas to support recovery of the resources.

**BOX 10.4**  
Proposed structure of ectones

**PROPOSED STRUCTURE OF ECTONES  
AIMED AT PROTECTING RESERVOIRS**

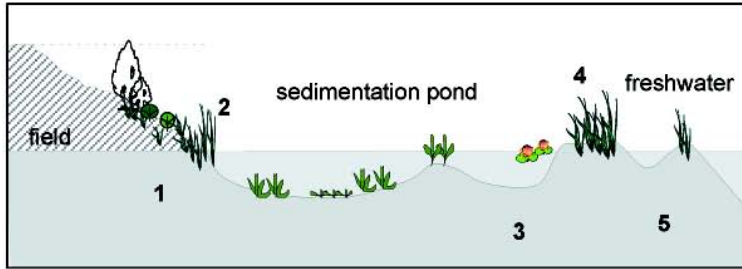

1. trees, shrubs (*Salix, Quercus, Betula, Alnus*); 2. rushes (*Phragmites, Typha, Sagittaria, Scirpus, Hydrocotyle*); 3. sedimentation ponds (*Nuphar, Lemna, Spirodela, Wolffia*); 4. rushes (*Iris, Juncus, Glyceria, Carex, Phragmites*); 5. ditch; 6. embankment covered with grasses and rushes (*Carex*)

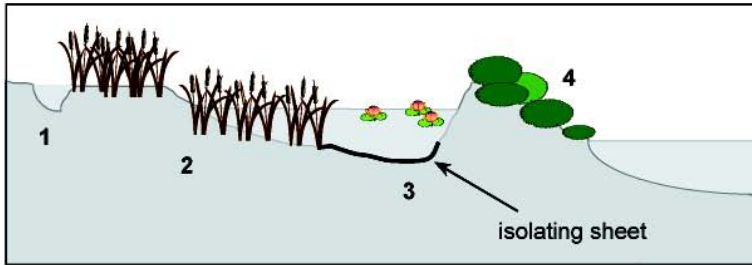

1. ditch; 2. rushes (*Phragmites, Typha, Glyceria*); 3. sedimentation ponds (*Nuphar, Lemna*); 4. Shrubs (*Salix*)

**PROPOSED STRUCTURE OF AN ECOTONE  
AIMED AT PROTECTING A RIVER**

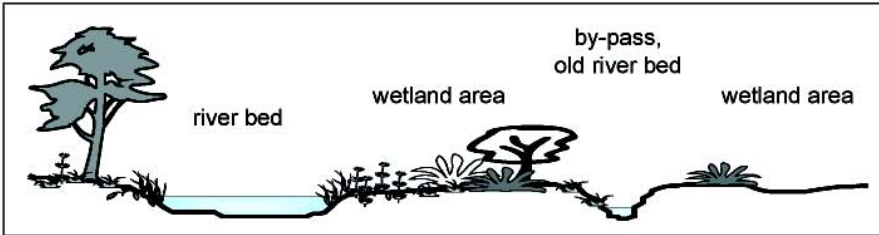

**SCHEME OF PLANT DISTRIBUTION ALONG THE RIVER BED**

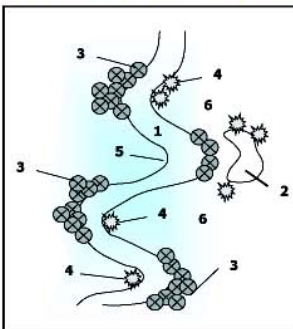

1. main river bed
2. old river bed, by-pass
3. area of compact tree vegetation
4. single trees or shrubs
5. open river bed (enable easy access to water)
6. wetland areas

It is suggested to situate compact tree cover only along the north and north-east banks (up to 100 %). Along the south, south-east and south-west banks tree cover should be more dispersed. It is not advised to apply dense tree and shrub cover along the river sections longer than 50 m.

**MAKE SURE TO CHECK THESE RESOURCES:**

Guidelines: chapters 4.E, 5.B-5.G

<http://www.eman-rese.ca/eman/ecotools/protocols/terrestrial/vegetation/glossary.html>

<http://www.gisdevelopment.net/aars/acrs/2000/ts12/index.shtml>

## ■ 10.C FLOODPLAINS AND NATURAL WETLANDS: REDUCTION OF NUTRIENT TRANSPORT

Rivers are located in the lowest parts of landscapes and therefore collect and transport pollutants downstream from catchments. In many regions, nutrients coming from non-point (dispersed) sources add up to more than 50% of the total nutrient load. Prevention of nutrient export from landscapes (see chapters 9.C, 10.A) is, therefore, necessary. The measures presented in this chapter prevent transfer of pollutants downstream via river systems. Lately it has been postulated that naturally flooded areas with evolutionarily developed vegetation can be very effective for this purpose (Science, 2002).



Fig. 10.4  
Lowland river floodplain - the Pilica River, Poland  
(photo: J. Wagner-Lotkowska)

### WHY ARE FLOODPLAINS IMPORTANT?

Floods are a natural element of undisturbed hydrological cycles of rivers. Floods occur with various frequencies, depending mostly on climatic characteristics of a region. During these events, large amounts of matter and nutrients derived from both landscape and riverbed erosion is deposited and retained in flooded areas. Consequently, floodplains are usually enriched with the transported material and, at the same time, river waters are purified by loss of this material. Floodplains can, therefore, serve as **natural cleaning systems** for reducing suspended matter, phosphorus, nitrogen and other nutrients and pollutants.

Floodplains are also very effective systems for **retaining water**. They can hold up to 1.5 million gallons of floodwater per acre. If they are destroyed, e.g., regulated and limited by engineered structures, the water that would have been contained within them to prevent flooding can no longer be stored effectively. This creates a flood risk in areas located downstream.

*Preservation of natural, and restoration of degraded, floodplains improves the quality of water and stabilizes hydrological parameters of rivers.*

### FLOODPLAINS ALONG A RIVER CONTINUUM

A river system's characteristics change considerably along its **longitudinal dimension** (see chapter 3.F). Therefore, the role of floodplains also changes depending on their location in the river continuum.

In the case of **upland rivers**, catchment slopes are usually steep and - especially in impermeable,

e.g., rocky areas - the retention of water in landscapes is often limited. In these cases, floodplains usually play an important role as a **flood prevention tool**. Their limited capacity in terms of water retention can be increased **by dry** pools. These can be filled during a flood event. The role of upland river floodplains in water quality improvement is less important than in lowland areas. Steep slopes usually restrict expansion of agriculture and, thus, the impact of these types of catchments on water quality is often low, unless deforestation is occurring.

In the case of **lowland rivers**, floodplains play a double role - **as both water quality and quantity tools**. They provide extensive areas for sedimentation of material transported from a catchment as the area of floodplains is usually greater than in upland rivers. Due to their diversified morphology and increased development of biomass, they also create conditions for a variety of other processes that can purify flood waters. At the same time, water retention in a landscape reduces propagation of flood waves downstream and reduces flood-induced hydro-peaking and low flow periods.

### WHAT PROCESSES CONTRIBUTE TO WATER QUALITY IMPROVEMENT IN FLOODPLAINS?

Among the various processes taking part in nutrient retention in floodplains, the following are the major ones:

- ▶ **sedimentation, filtration, and sorption** of particulate matter within wetlands due to long

water retention times and large sediment surface areas;

- ▶ **assimilation** of dissolved nutrients from both flood surface waters, as well as floodplain ground waters, by vegetation (**phytoremediation of nutrients**);
- ▶ **oxidation** and **microbial transformation** of organic matter in sediments; and
- ▶ **denitrification** of nitrogenous compounds by microbial action.

#### HOW TO ENHANCE NUTRIENT UPTAKE IN A FLOODPLAIN

The following four-step approach can be applied to elaborate a basis for the use of floodplains for nutrient load reduction:

- ▶ identification and **release of flood waters** with the highest organic matter and nutrient content to a floodplain area;
- ▶ **optimising conditions for physical sedimentation** of transported material on the basis of a hydraulic model of the area;
- ▶ **shaping the spatial distribution and composition of plant communities** of a floodplain based on its geomorphology and hydraulic characteristics; and
- ▶ **enhancing nutrient assimilation** and retention in biomass.

#### Releasing of flood waters high in nutrient content

The timing of nutrient loads transported by rivers is determined by several factors interacting with each other and changing over a year (Owens & Waling, 2002; Meybeck, 2002). Climate, catchment characteristics and river hydrology are usually considered to be the major ones (see Guidelines, chapter 7). The mechanisms of nutrient concentration changes with discharge are usually related to hydrological cycle pathways, and the role of its particular components in runoff formation from a catchment (Genereux & Hemmond, 1990; De Walle et al., 1991; Rice et al., 1995; Pekarova & Pekar, 1996; Russel et al., 2001). Usually, in the case of degraded catchments with a considerable contribution of non-point source pollutants, the concentration of nutrients during high water periods increases (Galicka, 1993; Chikita, 1996, Wagner & Zalewski, 2000; Zalewski et al., 2000). Surface runoff resulting from precipitation results in enhanced erosion and nutrient leaching and, thus, nutrient supply from a catchment.

In general, the following assumptions can be made:

- ▶ Nutrient concentrations during **moderate floods** are higher than during **flash floods**, when dilution of transported contaminants can occur (Wagner-Lotkowska, 2002). During flash floods nutrient loads can also be high, due to high hydraulic loading.

#### BOX 10.5

##### Releasing of nutrient condensing stage into a floodplain

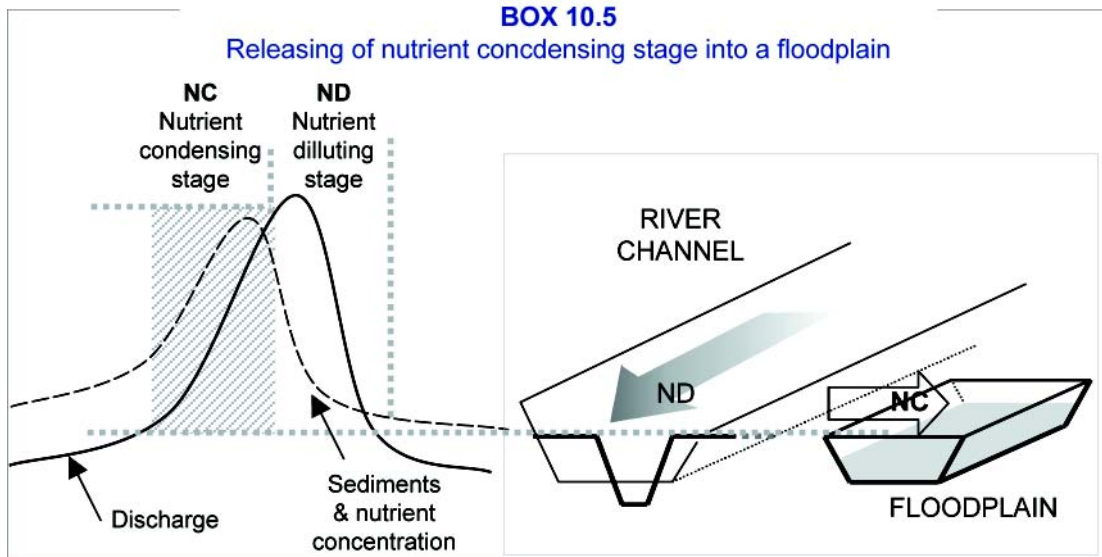



- ▶ Nutrient concentrations within a given river are greater during **frequent moderate floods** than during events of **longer duration, lower variability** and comparable hydraulic load. Nutrient loads transported in the first case are usually higher (Wagner-Lotkowska, 2002).
- ▶ The highest nutrient concentrations and loads during medium floods occur during **the first phase of a flood**, while the flood waters are rising (**nutrient-condensing stage**). In this phase of a flood, nutrient loads transported by a river are the highest (Wagner & Zalewski, 2000).
- ▶ Before river discharge reaches its maximum, nutrient concentrations and loads start to decrease and continue to decrease during the period following the flood peak (**nutrient-dilution stage**). The relationship between nutrient concentration and discharge often has the form of a clockwise hysteresis (Zalewski et al. 2000).

According to the above assumptions, in order to **improve the quality of water**, floodplains should be designed to retain nutrient and contaminant masses during the nutrient-condensing stage of moderate flow events (Box 10.5). Flooding can be controlled by adjusting the height of the threshold between a river and flooded area so that the inflow to the floodplain occurs at a specific level when nutrient concentrations start to increase during a rising hydrograph. This level should be determined empirically.

#### How to calculate nutrient load

A nutrient/pollutant load is the total amount of the nutrient/pollutant transported by a river, entering/leaving a lake or reservoir via a river, or from a pollution source over time.

$$L = C * Q$$

L - nutrient/pollutant load [mg day<sup>-1</sup>]

C - concentration [mg L<sup>-1</sup>]

Q - hydraulic load [L day<sup>-1</sup>]

#### Optimizing conditions for physical sedimentation

Morphology of a floodplain determines the hydraulics during inundation of an area. The hydraulics

determines not only water retention, but also about efficiency of sedimentation. Development of a hydrodynamic model of a floodplain, or an area being considered for use as a tool to improve water retention and quality, is important in the first stage of planning. Sedimentation can be enhanced by modification of the physical structure of an area and management of its vegetation cover.

#### Shaping the spatial distribution and composition of plant communities

Understanding and applying **phytotechnologies on floodplains** is important for two reasons: first, vegetation distribution determines the **hydraulics of an area**, and second, plant community composition controls the efficiency of dissolved **nutrient uptake and retention**.

Natural distribution and predomination of individual plant species is to a great extent dependent on the frequency of inundation and groundwater level (Box 10.6). Grass communities and rush vegetation usually appear on the highest parts of a floodplain. In periodically wet areas, hay meadows occur. Reedy rushes (e.g., *Caricetum gracilis* and *Carrex vesicaria*) occur in small mid-meadow hollows. Common reeds (*Phragmitetum australis*), with common reeds (*Phragmites australis*) as the dominant species, appear in places consistently covered by water, such as old river beds, where they form extensive monotypic aggregations.

Maintenance of this biodiversity enhances the ecological stability of a floodplain ecosystem, as well as the efficiency of purification. Each of the communities is usually most effective in terms of biomass production and nutrient uptake under their optimal conditions.

#### Enhancement of nutrient assimilation processes

Knowing the potential **capability of** certain species of specific plants **to sequester nutrients** is very important for estimating the amount of nutrients that can be accumulated per surface unit. This capability depends on **biomass production and percentage of nutrient accumulation**.

As water and temperature are the major driving forces for biological processes, the greatest increase in biomass takes place in summer (temperate re-

**BOX 10.6**  
Distribution of vegetation depending on water level

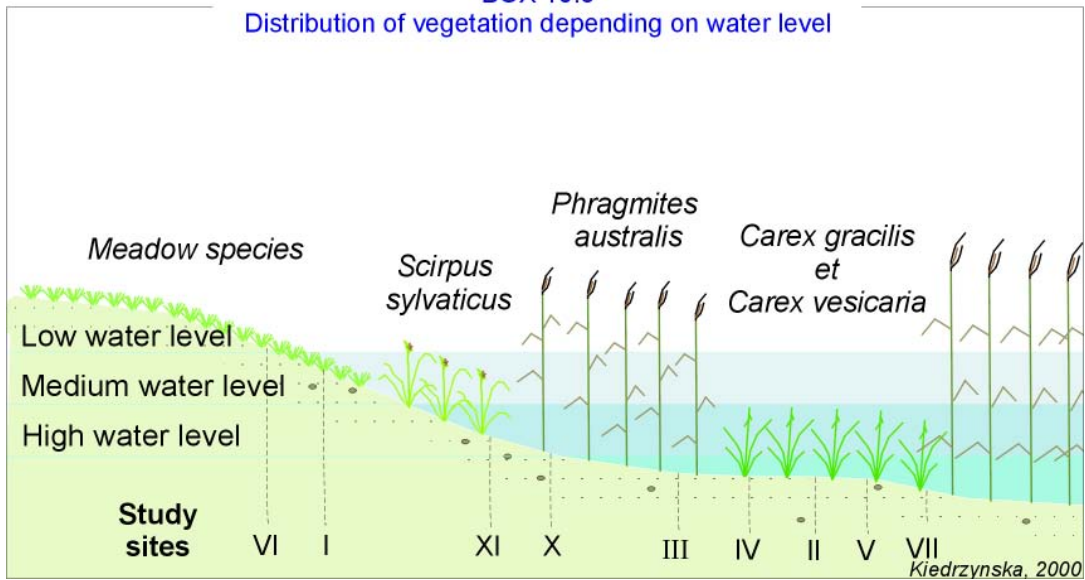

gions) or during wet seasons (tropics). The size of the peak summer biomass is important in a plant development cycle, as it determines to a great extent the amount of nutrients that can be accumulated.

**Biomass** production depends on a plant species or community type. For example, reedy rushes can achieve a biomass of 14 000 kg of dry mass ha<sup>-1</sup>, sedge rushes and rushes of the forest bulrush - 3 800 and 2 800 kg ha<sup>-1</sup>, respectively; common reeds (*Phragmites australis*) - between 30 000 and 35 000 kg; reeds - between 6 000 and 35 000 kg of dry mass ha<sup>-1</sup> (Seidel, 1966; Bernatowicz & Wolny, 1974; Koc & Polakowski, 1990; Ozimek & Renman, 1995). According to Goldyn & Grabia (1996), the harvest of grasses in a summer period totals between 11 000 and 14 000 kg of dry mass ha<sup>-1</sup> (for more information, see chapter 10.B). The ability of plants to **accumulate phosphorus** in their tissues usually ranges from 0.1 to 1% (Fink, 1963). It may, however, vary considerably with different **plant species**. For example, the phosphorus content in the biomass of the common reed, *Phragmites australis*, ranges between 0,01 and 0,5%. For *Carex* species, the percentage phosphorus in the dry mass falls within the range of 0,08 to 0,8% (Bernatowicz & Wolny, 1974; Szczepanski, 1977; Ozimek, 1991; Kiedrzyńska, 2001). Phosphorus in the biomass of *Scirpus americanus* amounts to 0,18% (Kadlec & Knight, 1995).

In some species, phosphorus storage differs depending on **plant age** (Box 10.7). Therefore, the management of vegetation focused on maximizing nutrient uptake should take these aspects into consideration. For example willow are usually removed every three years, what compromise between nutrient removal and economic benefits - high biomass, energetic value and efficiency of harvesting. To maximize phosphorus uptake in biofiltering systems, the vegetation should be properly managed. The best results are achieved by creating in-

**BOX 10.7**  
Amount of phosphorus removed with 100 kg of *Salix purpurea*

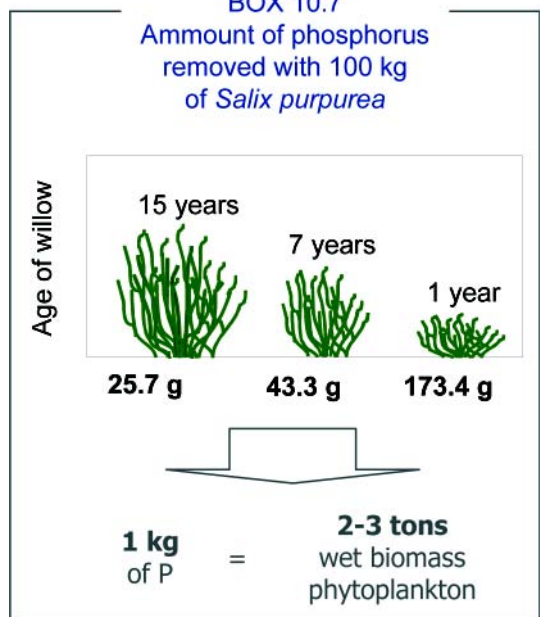

intermediate patches of different types of land cover because it causes the vegetation to better adapt to abiotic conditions and increases the biodiversity of the area. Vegetation should also be seasonally removed from wetlands, e.g., every 3-5 years in the case of willows. This is because willows maintain the highest growth rate and effectiveness of phosphorus uptake within this period (Zielinska, 1997). Removing vegetation after the growth season prevents the release of nutrients back into the water in autumn.

### MYCORRHIZA - HOW PLANTS ADAPT TO HIGH WATER LEVELS

The soil around plant roots are enriched with **symbiotic organisms, such as bacteria and fungi**, which create suitable conditions for plant growth. The microbiological activity of a rhizosphere is crucial for plant growth and natural resistance to pathogens (Azcón-Aguilar & Barea, 1992; Smith & Read, 1997; Linderman, 2000). Symbiotic fungi are an important component. Mycelium penetrate the top layer of soil, connecting sand grains in larger aggregates (Koske et al., 1975; Sutton & Sheppard, 1976) or excreting substances that act as a glue for soil particles (Miller & Jastrow, 2000). Due to mycelium, the absorbing surfaces of roots are much better developed, which improves nutrient transport to plants (e.g., Cox & Tinker, 1976). Fungi colonize more than 90% of plant species in natural ecosystems (Read et al., 1992). Mycorrhizal, mutual symbiosis is widespread in all kinds of environments. Two types are recognized:

- ▶ ectomycorrhizae; and
- ▶ endomycorrhizae.

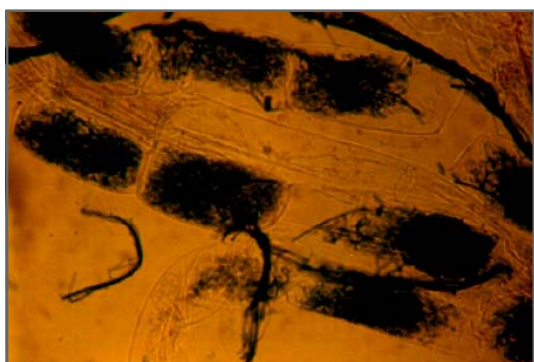

Fig. 10.6  
Arbuscule in *Hypericum* sp. cells  
(photo: B. Sumorok)



Fig. 10.5  
Black mantle on *Populus tremula* roots  
(photo: B. Sumorok)

In **ectomycorrhizal symbiosis** the mantle (Fig. 10.5) is connected to highly branched hyphae that **penetrate the root and grow between cells**. This hyphal network (hartig net) is the site of nutrient exchange. **Endomycorrhizal fungi** produce a highly branched hyphal structure called an arbuscule **within a plant cell** - it is the site of nutrient exchange (Fig. 10.6).

In temperate zone forests ectomycorrhiza are dominant, which is in contrast to tropical forests and herbaceous communities where endomycorrhiza are more important (Harley & Smith, 1983). Mycorrhizal plants are more and more frequently used for restoration processes and for bioremediation - **phytostabilization, phytodegradation and phytoextraction**. Selected species bind and accumulate heavy metals in their tissues (Bloomfield, 1981; Blaylock et al., 1995; Salt et al., 1995) and can be removed from reclaimed areas by cutting (Kumar et al. 1995).

In the process of reclamation of polluted areas, the reed *Phragmites australis* is used; the mycorr-

hizal status of this plant can vary from non-mycorrhizal to mycorrhizal (Harley & Harley, 1987; Willby et al., 2000, Oliveira et al., 2001). The plants most frequently used as biofilters are different species and varieties of willow, which can be either ecto- or endomycorrhizal (Harley & Harley 1987).

#### RECOMMENDATIONS FOR PHYTOTECHNOLOGICAL APPLICATIONS IN FLOODPLAIN AREAS

Results obtained in the first year of implementation of the UNESCO/UNEP Demonstration Project on Application of Ecohydrology and Phytotechnology in IWM (Pilica River, Poland) provided information on the application of phytotechnology in floodplain areas.

The following recommendations have been formulated for willow planting:

##### Recommendations for willow planting

- ▶ only extensive willow planting can be applied in floodplain areas;
- ▶ no, or only shallow, ploughing is to be applied prior to establishment of willow patches in order to minimize soil erosion and leaching of nutrients;
- ▶ **no fertilizers and other agents** can be applied so as to prevent an increase of eutrophication, or nutrient pollution;
- ▶ monocultures of energetic species can not be planted in order to **preserve the natural biodiversity in river corridors**. The structure of **patches of autochthonous vegetation and autochthonous/energetic willows** (if allowed in a given region) should be maintained. Controlled patches of energetic willow should not exceed 30% of a floodplain

area. Results of research on the rate of growth and phosphorus accumulation by various vegetation communities and willow species showed that application of various vegetation patches enhances phytoremediation processes. This results from adaptation and optimum growth of particular species in various environmental conditions. In order to optimize biomass growth and phosphorus accumulation, vegetation should be adapted to the timing of flooding and number of days with high ground water and surface water levels.

#### Socio-economic aspects

Floodplain areas are natural, self-sustaining systems where purification processes are driven by natural forces. Combining water purification, due to specific phytotechnologies like phytoextraction or rizodegradation, can not only solve specific water pollution problems, but also provide other benefits. Using fast growing plants (willows, reeds, or other native species in a region) can provide economic profits for local communities. According to the ecohydrology concept, potential threats, e.g., water pollutants, can be converted into opportunities such as energy sources. Biomass production, which can be later utilized for bioenergy, is such an example.

Development of the logistics for bioenergy utilization in a region can involve not only the biomass produced on a floodplain, but also that from **forestry** and agricultural overproduction (e.g., **straw surplus**). An alternative solution can be the introduction of specialized **energy crops** - especially willow - in areas remote from river corridors.

#### MAKE SURE TO CHECK THESE RESOURCES:

Guidelines: chapter 7

## 11.A. RESTORATION OF PHYSICAL STRUCTURES IN A RIVER

The physical assessment of stream conditions lies within a broad framework of environmental restoration. Several multimetric and multivariate assessment methods are used to estimate the status and potential for restoration of river ecosystems. This chapter points out some main restoration approaches and physical structure restoration techniques necessary to achieve ecological integrity in degraded river ecosystems.



Fig. 11.1  
Natural section of the Oder River  
(photo: Z. Kaczowski)

### WHAT SCALES SHOULD BE CONSIDERED FOR RIVER RESTORATION?

Riverine habitats are organized hierarchically in a basin context (Box 11.1; Frissell et al., 1986) and should be especially considered during restoration projects.

### HOW TO PLAN RESTORATION?

Most river rehabilitation methods recommend the use of a pre- and post-restoration assessment of conditions to check the effectiveness of river restoration.

For example, this includes a description of present stream conditions and evaluation of the success of the rehabilitation process (Box 11.2).

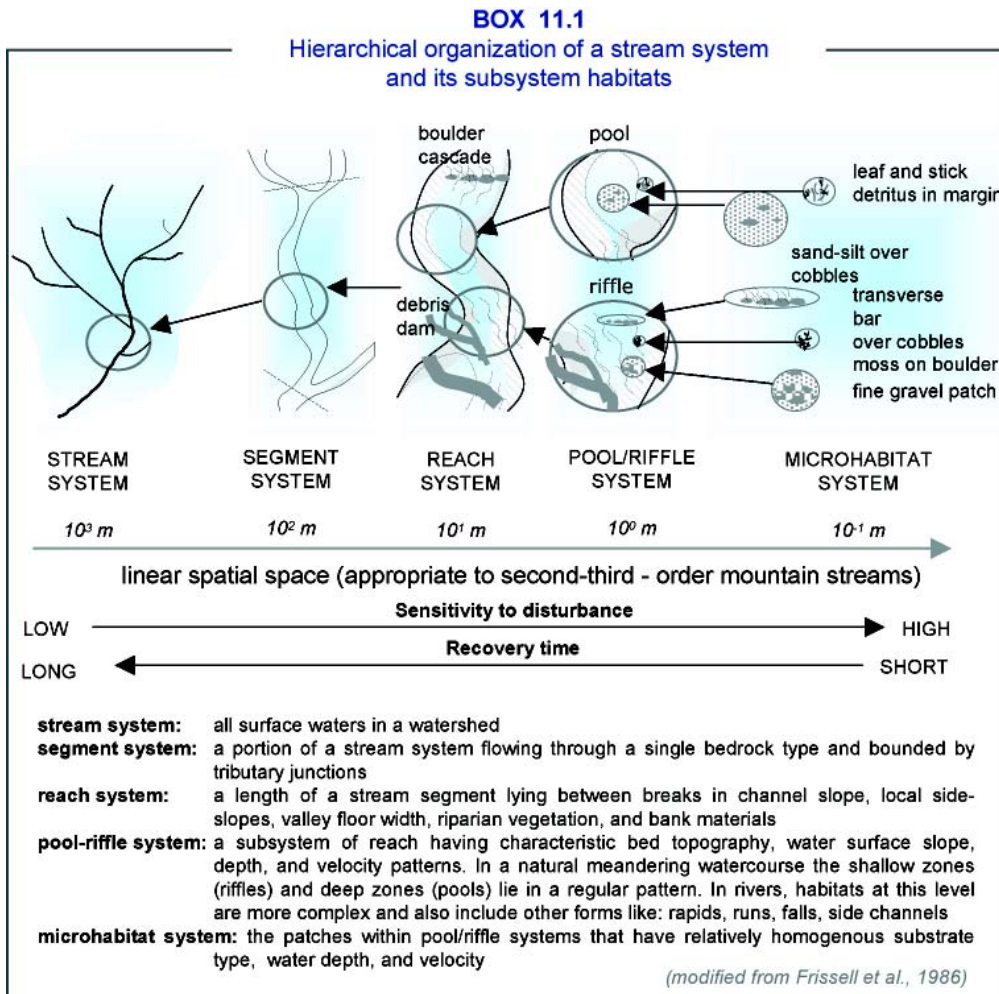

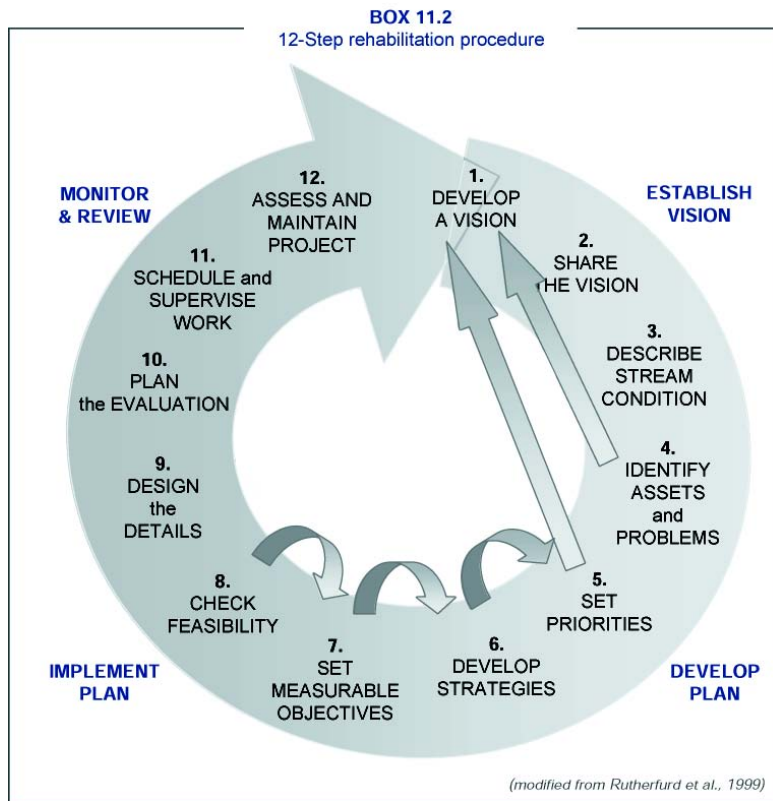

**WHAT IMPACT CATEGORIES SHOULD BE CONSIDERED IN RIVER MANAGEMENT?**

Human-induced impacts to river systems fall into 5 major categories (Table 11.1). All these variables are important for ecological integrity (EI) of a river ecosystem and should be considered in management plans.

**WHAT METHODOLOGY CAN BE USED IN A DECISION-SUPPORT SYSTEM FOR RIVER MANAGEMENT?**

Several physical assessment methods can support restoration options of degraded river ecosystems (see chapters in the Part Two: Surveys and Assessment).

**TABLE 11.1**  
Human impacts on river ecosystems

<b>FLOW REGIME</b>	<b>HABITAT STRUCTURE</b>	<b>WATER QUALITY</b>	<b>FOOD SOURCE</b>	<b>BIOTIC INTERACTIONS</b>
Discharge	Habitat diversity	Nutrients	Algal production	Exotic species
Water depth	Siltation	Thermal regime	Energy input	Endemic species
Water velocity	Bank stability	Turbidity	Particulate organic matter	Threatened and endangered species
Flood frequency	Cover	Salinity	Aquatic invertebrates	Hybridization
Flood magnitude	Woody debris	Dissolved oxygen	Terrestrial invertebrates	Population structure
Drought frequency	Channel sinuosity	pH		Competition
Flow variability	Habitat connectivity	Toxins		Species richness
				Predation
				Trophic structure

*(after Karr et al., 1986)*

**WHAT TECHNIQUES CAN BE USED IN RESTORATION OF A RIVER'S PHYSICAL STRUCTURE?**

Several techniques of river physical structure restoration, as listed and described in Table 11.2,

include the following groups of practices:

- ▶ instream processes;
- ▶ stream bank treatment; and
- ▶ channel reconstruction.

**TABLE 11.2**  
Techniques for restoring the physical structure of a river

<b>INSTREAM PRACTICES</b>		
<b>Practice</b>	<b>Practice description</b>	<b>Application</b>
Boulder Clusters	Groups of boulders placed in the base flow channel to provide cover, create scour holes, or areas of reduced velocity.	Can be used in most stream habitat types including riffles, runs, flats, glides and open pools.
Weirs or Sills	Log, boulder, or quarry stone structures placed across the channel and anchored to the stream bank and/or bed to create pool habitat, control bed erosion, or collect and retain gravel.	Create structural and hydraulic diversity in uniform channels.
Fish Passages	Any one of a number of in-stream changes which enhance the opportunity for target fish species to freely move to upstream areas for spawning, habitat utilization, and other life functions.	Can be appropriate in streams where natural or human placed obstructions such as waterfalls, chutes, logs, debris accumulations, beaver dams, dams, sills, and culverts interfere with fish migration.
Log/Brush/Rock Shelters	Logs, brush, and rock structures installed in the lower portion of stream banks to enhance fish habitat, encourage food web dynamics, prevent stream bank erosion, and provide shading.	Most effective in low gradient stream bends and meanders where open pools are already present and overhead cover is needed.
Lunker Structures	Cells constructed of heavy wooden planks and blocks which are imbedded into the toe of stream banks at channel bed level to provide covered compartments for fish shelter, habitat, and prevention of stream bank erosion.	Appropriate along outside bends of streams where water depths can be maintained at or above the top of the structure.
Migration Barriers	Obstacles placed at strategic locations along streams to prevent undesirable species from accessing upstream areas.	Effective for specific fishery management needs such as separating species or controlling nuisance species by creating a barrier to migration.
Tree Cover	Felled trees placed along the stream bank to provide overhead cover, aquatic organism substrate and habitat, stream current deflection, scouring, deposition, and drift catchment.	Particularly advantageous in streams where the bed is unstable and felled trees can be secured from the top of a bank.  Channels must be large enough to accommodate trees without threatening bank erosion and limiting needed channel flow capacity.
Wing Deflectors	Structures that protrude from either stream bank but do not extend entirely across a channel. They deflect flows away from the bank, and scour pools by constricting the channel and accelerating flow.	Can be installed in series on alternative stream banks to produce a meandering thalweg and associated structural diversity.  Should be used in channels with low physical habitat diversity, particularly those with a lack of stable pool habitat.
Grade Control Measures	Rock, wood, earth, and other material structures placed across a channel and anchored in the stream banks to provide a "hard point" in the streambed that resists the erosional forces of the zone of degradation, and/or to reduce the upstream energy slope to prevent bed scour.	Used to stop head cutting in degrading channels.  Used to build bed of incised stream to higher elevation.  Can improve bank stability in an incised channel by reducing bank heights.  Man-made scour holes downstream of structures can provide improved aquatic habitat.  Upstream pool areas created by structures provide increased low water depths for aquatic habitat.  Potential to become low flow migration barrier.  Can be designed to allow fish passage.

(from FISRWG, 10/1998)

**TABLE 11.2 - cont**  
Techniques for restoring the physical structure of a river

<b>STREAM BANK TREATMENT</b>		
<b>PRACTICE</b>	<b>PRACTICE DESCRIPTION</b>	<b>APPLICATION</b>
Bank Shaping and Planting	Regarding stream banks to a stable slope, placing topsoil and other materials needed for sustaining plant growth, and selecting, installing and establishing appropriate plant species.	Most successful on stream banks where moderate erosion and channel migration are anticipated.
Branch Packing	Alternate layers of live branches and compacted backfill which stabilize and revegetate slumps and holes in stream banks.	Commonly used where patches of stream banks have been scoured out or have slumped leaving a void.
Brush Mattresses	Combination of live stakes, live facines, and branch cuttings installed to cover and physically protect stream banks; eventually to sprout and establish numerous individual plants.	Form an immediate protective cover over the stream bank.
Coconut Fiber Roll	Cylindrical structures composed of coconut husk fibers bound together with twine woven from coconut material to protect slopes from erosion while trapping sediment which encourages plant growth within the fibre roll.	Appropriate where moderate toe stabilization is required in conjunction with restoration of the stream bank and the sensitivity of the site allows for only minor disturbance.  Provide an excellent medium for promoting plant growth at the water's edge.
Dormant Post Plantings	Plantings of cottonwood, willow, poplar, or other species embedded vertically into stream banks to increase channel roughness, reduce flow velocities near the slope face, and trap sediment.	Can be used as live piling to stabilize rotational failures on stream banks where minor bank sloughing is occurring.  Useful for quickly establishing riparian vegetation, especially in arid regions where water tables are deep.
Vegetated Gabions	Wire-mesh, rectangular baskets filled with small to medium size rocks and soil and laced together to form a structural toe or sidewall. Live branch cuttings are placed on each consecutive layer between the rock filled baskets to take root, consolidate the structure, and bind it to the slope.	Useful for protecting steep slopes where scouring or undercutting is occurring or there are heavy loading conditions.  Vegetative plantings to stabilize the upper bank and ensure a regenerative source of stream bank vegetation.
Joint Plantings	Live stakes tamped into joints or openings between rocks which have previously been installed on a slope or while rock is being placed on the slope face.	Appropriate where there is a lack of desired vegetative cover on the face of existing or required rock riprap.  Root systems provide a mat upon which the rock riprap rests and prevents loss of fines from the underlying soil base.  Root systems also improve drainage in the soil base.  Will quickly establish riparian vegetation.
Live Crib Walls	Hollow, box-like interlocking arrangements of untreated log or timber members filled above base flow with alternate layers of soil material and live branch cuttings that root and gradually take over the structural functions of the wood members.	Provide protection to the stream bank in areas with near vertical banks where bank sloping options are limited.  Afford a natural appearance, immediate protection and accelerate the establishment of woody species.  Effective on outside of bends of streams where high velocities are present source of stream bank vegetation.



**TABLE 11.2 - cont**  
Techniques for restoring the physical structure of a river

<b>STREAM BANK TREATMENT</b>		
<b>PRACTICE</b>	<b>PRACTICE DESCRIPTION</b>	<b>APPLICATION</b>
Live Stakes	Live, woody cuttings which are tamped into the soil to root, grow and create a living root mat that stabilizes the soil by reinforcing and binding soil particles together, and by extracting excess soil moisture.	Effective where site conditions are uncomplicated, construction time is limited, and an inexpensive method is needed. Appropriate for repair of small earth slips and slumps that are frequently wet. Can be used to stake down surface erosion control materials. Requires toe protection where toe scour is anticipated.
Live Fascines	Dormant branch cuttings bound together into long sausage-like, cylindrical bundles and placed in shallow trenches on slopes to reduce erosion and shallow sliding.	Can trap and hold soil on stream bank by creating small dam-like structures and reducing the slope length into a series of shorter slopes. Facilitate drainage when installed at an angle on a slope. Enhance conditions for colonization of native vegetation.
Log, Root Wad, and Boulder Revetments	Boulders and logs with root masses attached placed in and on stream banks to provide stream bank erosion, trap sediment, and improve habitat diversity.	Will tolerate high boundary shear stress if logs and root wads are well anchored. Suited to streams where fish habitat deficiencies exist.
Riprap	A blanket of appropriately sized stones extending from the toe of slope to a height needed for long term durability.	Appropriate where long term durability is needed, design discharges are high, there is a significant threat to life or high value property, or there is no practical way to otherwise incorporate vegetation into the design. Can be vegetated (see joint plantings). Commonly used form of bank protection.
Stone Toe Protection	A ridge of quarried rock or stream cobble placed at the toe of a stream bank as armor to deflect flow from the bank, stabilize the slope and promote sediment deposition.	Should be used on streams where banks are being undermined by toe scour, and where vegetation cannot be used. Stone prevents removal of the failed stream bank material that collects at the toe, allows revegetation and stabilizes stream banks.
Tree Revetments	A row of interconnected trees attached to the toe of a stream bank or to dead heads in a stream bank to reduce flow velocities along eroding stream banks, trap sediment, and provide a substrate for plant establishment and erosion control.	Works best on streams with stream bank heights under 12 feet and bank-full velocities under 6 feet per second. Captures sediment and enhances conditions for colonization of native species particularly on streams with high bed material loads.
Vegetated Geogrids	Alternating layers of live branch cuttings and compacted soil with natural or synthetic geotextile materials wrapped around each soil lift to rebuild and vegetate eroded stream banks.	Quickly establishes riparian vegetation if properly designed and installed. Can be installed on a steeper and higher slope and has a higher initial tolerance of flow velocity than brush layering.

*(from FISRWG, 10/1998)*

**TABLE 11.2 – cont**  
 Techniques for restoring the physical structure of a river

<b>CHANNEL RECONSTRUCTION</b>		
<b>PRACTICE</b>	<b>PRACTICE DESCRIPTION</b>	<b>APPLICATION</b>
Maintenance of Hydraulic Connections	Maintenance of hydraulic connectivity to allow movement of water and biota between the stream and abandoned channel reaches.	Used to prevent losses of aquatic habitat area and diversity. Slack water areas adjoining the main channel have potential for spawning and rearing areas for many fish species and are a key component of habitat for wildlife species that live in, or migrate through, the riparian corridor.
Stream Meander Restoration	Transformation of a straightened stream into a meandering one to reintroduce natural dynamics to improve channel stability, habitat quality, aesthetics, and other stream corridor functions or values.	Used to create a more stable stream with more habitat diversity. Requires adequate area where adjacent land uses may constrain locations.

*(from FISRWG, 10/1998)*

**MAKE SURE TO CHECK THESE RESOURCES:**

Guidelines: chapter 6

## 11.B. RESTORATION OF VEGETATION: INCREASING NUTRIENT RETENTION CAPACITY AND SELF-PURIFICATION ABILITY

The role of macrophytes in floodplain management and freshwater protection has been highlighted by many authors. It is also worth stressing that they play a crucial role in the restoration and management of rivers. Macrophyte biomass and distribution directly influence the water chemistry and hydraulics of river systems. Indirectly they significantly modify biological diversity through space partitioning and creation of habitats. The aim of this chapter is to present basic concepts related to use of macrophytes in river restoration and management projects.



Fig. 11.2  
*Ecotones are stabilizers of nutrient cycles and buffers against alterations*  
(photo: V. Santiago-Fandino)

### WHY RESTORE PLANTS IN RIVER CHANNELS?

The role of plants in river channel includes:

- ▶ decrease of flow velocity and dissipation of wave energy (by stems and leaves);
- ▶ anchoring sediments by plant roots, which increases channel roughness;
- ▶ changes in bottom structure and distribution of flow velocities - decrease of «active» cross-section of a channel;
- ▶ raising the water level in a river channel and neighboring areas;
- ▶ accelerating ice-cover break-up and removal; and
- ▶ regulation of suspended matter transport.

*All the above factors lead to a decrease of bottom erosion and bank abrasion and, consequently, increase maximal allowable flow velocities. In channels devoid of vegetation it should not exceed  $0,45 \text{ m s}^{-1}$  for silt and sandy bottoms,  $0,6 \text{ m s}^{-1}$  for organic substrates, and  $0,7 \text{ m s}^{-1}$  for clay. In the case of vegetated channels, velocities may reach  $0,9 \text{ m s}^{-1}$  with poor plant cover,  $1,2 \text{ m s}^{-1}$  for well developed cover and  $1,5 \text{ m s}^{-1}$  for dense vegetation.*

### WHAT FACTORS DETERMINE VEGETATION EFFICIENCY?

The role of plants depends on:

- ▶ type of plant community;
- ▶ mechanical characteristics of individual species;
- ▶ substrate properties; and
- ▶ flow velocity and water depth.

It also changes depending on the season. Usually plants are active for 200-225 days a year, but the vegetation of some communities can be continuous.

### USE OF AQUATIC PLANTS FOR RIVER MANAGEMENT

The role of plants is most pronounced in rivers up to **2 metres deep** (during the highest discharges). Plant expansion is regulated by **temperature, light access, flow distribution in a channel, nutrient concentrations and oxygen concentration**. Other important factors regulating plant growth and role are hydraulic resistance of the channel and periodical changes in bottom and bank shape. Therefore, proper introduction of vegetation for sustainable river management requires:

- ▶ precise calculation of water movement parameters;
- ▶ an understanding of channel hydraulics; and
- ▶ knowledge about biomass distribution and ecology of dominant plant species.

Table 11.3 presents some of the major riverine species - representatives of ecological groups - and remarks related to their application in river management.

Some plant species are not suitable for improving river habitats, because:

- ▶ they present a health hazard, e.g., *Heracleum mantegazzianum* (giant hogweed), *Conium maculatum* (hemlock);
- ▶ they are invasive, therefore, difficult to con-

**TABLE 11.3**  
Application of the major riverine plant species in river management

SPECIES	OTHER REPRESENTATIVES OF THE GROUP	REMARKS
<b><i>Elodea canadensis</i></b>	<i>Hydrilla</i> spp., <i>Calitriche</i> spp	create large 'dead zones' [with low flow velocities], tolerates flow velocities up to 0,15 m s <sup>-1</sup> , its growth is very intense at temp. of 16-19°C, during most of the summer causes water increases up to 50% of average water depth
<b><i>Nuphar</i></b>	all species	its stems and leaves lower flow velocities down to 0,1-0,05 m s <sup>-1</sup> , well developed rhizomes and roots protect bottom against erosion, causes water increases up to 12% of average water depth
<b><i>Sagittaria</i></b>	<i>Sparganium</i>	does not create dead zones but can break the current, lowering its velocity and causing uniform, slow accumulation of suspended matter, it is active only 7 months per year, after the growing period it is not efficient in preventing channel erosion
<b><i>Potamogeton</i></b>	all species	active for about 5 months, lowers water velocity and creates dead zones
<b><i>Phragmites</i></b>	<i>Glyceria</i> , <i>Schoenoplectus</i> , <i>Butomus</i>	can break the current lowering its velocity

trol, e.g., *Reynoutria japonica* (Japanese knotweed), *Stratiotes aloides* (water soldier), *Impatiens glandulifera* (Himalayan balm), *Nymphaoides peltata* (fringed water lily); and  
 ► *Phragmites australis* (Norfolk reed), *Typha latifolia* (bullrush) are suitable only for large rivers (NRA Severn-Trent Region).

Also very important is an assessment of the influence of chemical and mechanical plant removal methods on the microflora and microfauna, matter accumulation and rate of biomass decay. Eventually these processes may lead to ecological catastrophes downstream due to oxygen depletion and degradation of habitats.

**MAINTENANCE**

The role of plants, as components modifying and preparing in-stream conditions for organisms, is sometimes questioned because they may decrease channel flow capacity and increase the risk of floods.

**What has to be considered before plant removal?**

Decisions about mechanical removal of plants should be taken carefully after analyzing:

- possible threat of valley flooding if existing vegetation is left undisturbed;
- retentiveness of river bed and valley during rising discharges;
- water levels at which plants are removed from the channel by currents; and
- natural mechanisms limiting plant growth and expansion.

**What are the advantages of vegetation control?**

In some situations it is impossible to avoid maintaining removal operations. Control of in-stream vegetation is important because:

- it stops the rise of water level caused by flow impedance;
- it opens areas of clear water important for organisms, habitat diversity and users of water bodies; and
- in autumn it prevents the blockage of culverts, pumps and sluices with washed-out plants.

**Control of riparian vegetation:**

- encourages root development - enhancement of bank stability;
- prevents invasion of shrubs;

- ▶ prevents large organic matter and debris accumulation; and
- ▶ provides access to the water for users.

### How to protect the functions of river ecosystems.

In cases when some intervention is necessary for conservation reasons, some important considerations are:

- ▶ leaving, wherever possible, undisturbed sections of the river or at least parts of the middle and edge - they act as refugia for plants and animals and allow recolonization (Box 11.3);
- ▶ timing of plant cutting;
- ▶ cutting and dredging operations should be conducted not more than every few years and all operations should be combined;

- ▶ aquatic plants, which have been disturbed during dredging, should be transplanted and a minimum amount of silt left in the channel to retain its profile (Box 11.4); and
- ▶ fish and invertebrates should be protected during all maintenance operations and fish spawning seasons avoided.

Some alternative solutions maybe: partial shading of a river bed, change in the cross-section shape, and enhancing reproduction of herbivores.

### PLANT INTRODUCTION AND PROTECTION

Marginal and emergent plants should not be placed in areas with water depths greater than 20 cm (Table 11.4). It is also highly advised to use structures that protect plants from wave action and flushing by currents. This maybe done by use of a plastic pipe boom or by creating bays. In both cases, two goals are obtained - plant protection,

**BOX 11.3.**  
Two types of river channel management

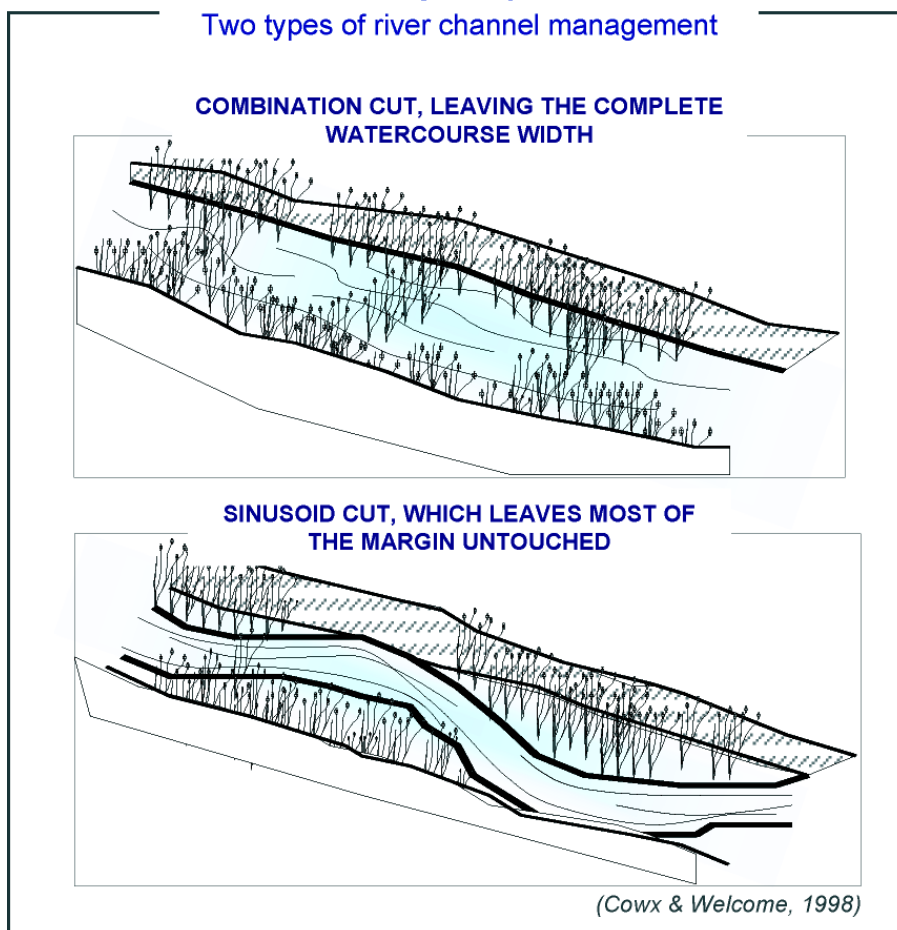

**BOX 11.4**

During maintenance operations some river sections have to be left undisturbed. This enhances colonization processes, protects biodiversity, and preserves the natural character of a river. It is also important to maintain the profile of the channel with bays and meanders because they provide habitats for macrophytes and, therefore, feeding, spawning and nursery areas for fish

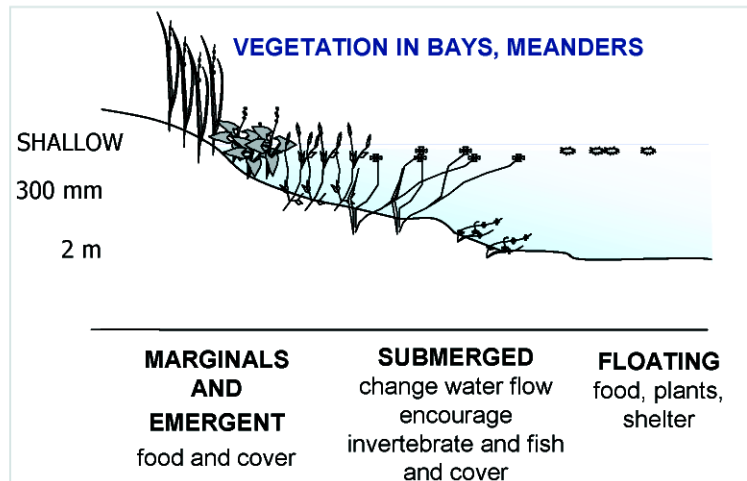
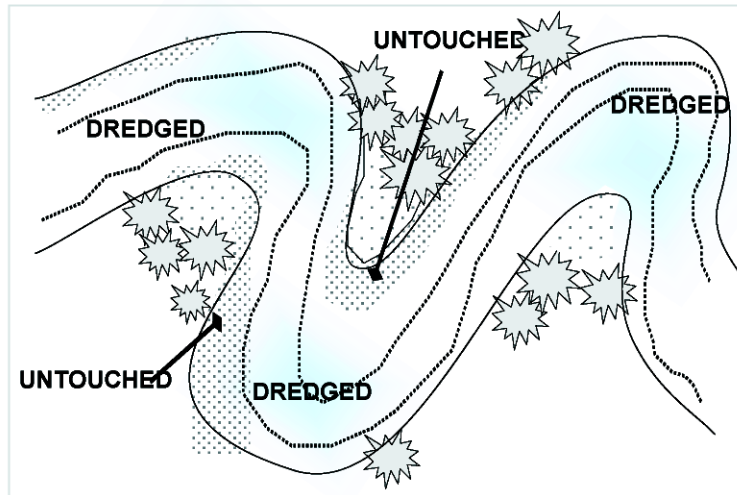

(NRA Severn-Trent Region)

and creation of diverse habitats for invertebrates and fish (Box 11.5).

Species having rhizomes should not be grown from seeds (Box 11.5). In the case of reeds it is better to establish plants in drier soils and allow them to spread naturally.

Before planting floating leaved or submerged plants in water that has little organic matter, they should be first placed in sacks filled with 50:50 soil and rooted manure or compost.

**TABLE 11.4**  
How deep should be macrophytes planted

PLANT TYPE	DEPTH OF WATER
marginals, emergents	up to 20 mm
floating leaved, submergents	up to 2000 mm
common reed	500-2000 mm

### CONCLUDING REMARKS

Application of phytotechnologies, based on the planting of vegetation within, or on, banks of stream channels, increases the self-purification potential of water ecosystems and enhances a fish-

ry, nature conservation and aesthetic values. However, all the operations have to be preceded with careful analysis of their objectives, as well as the time, effort, and costs necessary for protection and maintenance of vegetation.

#### BOX 11.5

#### Enhancement of riparian and aquatic vegetation through protection from waves and current action

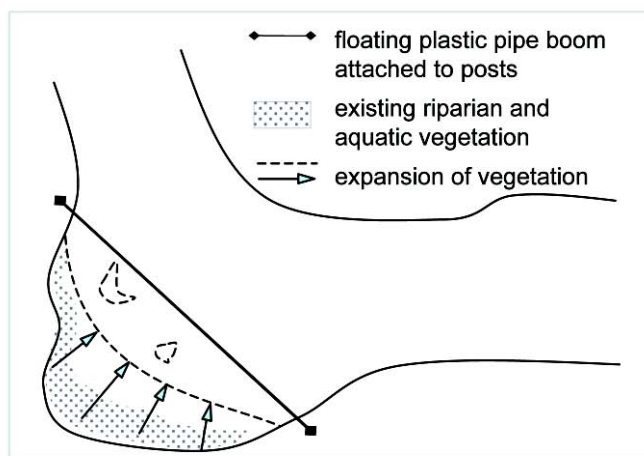

(modified from Cowx & Welcome, 1998)

#### Notch planting of rooted plants, rhizomes and marginal plants, and introduction of floating leaved or submerged plants

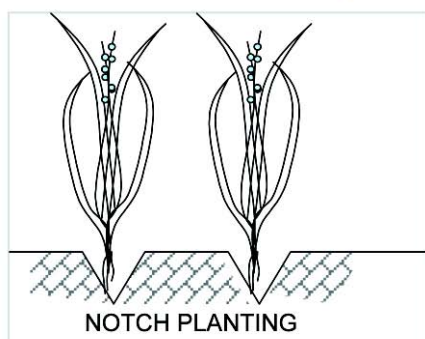

(modified from NRA Severn- Trent Region)

#### MAKE SURE TO CHECK THESE RESOURCES:

Guidelines: chapter 6

<http://home.arcor.de/limnologie/Boehme.htm>

<http://www.aquabotanic.com/paper2-4.html>

<http://www.unece.org/env/water/documents/icpdr.pdf>

<http://www.aquatic.uoguelph.ca/plants/macrophytes/plantframe.htm>

## 11.C. MANAGEMENT OF SHORELINE AND RIVERBED STRUCTURES: INCREASING FISH YIELDS

Riparian vegetation, the main structural element of shorelines, stabilize river banks, are a source of important organic matter for a river, and determine the input of solar energy to a river. This directly influences algal and macrophyte primary productivity and indirectly influences productivity of higher trophic levels like invertebrates and fish. This chapter gives quantitative examples of how stream bank structure should be maintained or restored for increasing fish yields.



Fig. 11.3  
Examples of various shoreline vegetation structures (photo: K. Krauze)

### WHY SHORELINE STRUCTURE IS IMPORTANT FOR FISH

Shoreline structure plays an important role in supporting both biomass and biodiversity of fish in rivers (Table 11.5). Fish respond especially quickly to changes in habitat structure. For example, the removal of woody debris can cause close to a 50% decrease in fish biomass and diversity (Lapinska et al., 2002; Zalewski et al., 2003) - Box 11.6.

### HOW MUCH RIPARIAN VEGETATION SHOULD BE CONSIDERED?

According to the Intermediate Complexity Hypothesis (Zalewski et al., 1994) optimal energy pathways might be obtained in river channels with an intermediate complexity of riparian vegetation. It has been found for small-size upland and low-

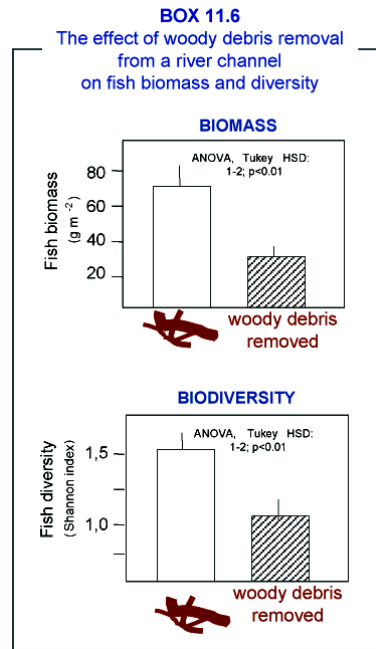

TABLE 11.5

The functions of shoreline riparian vegetation for rivers

SITES	COMPONENTS	FUNCTIONS
<b>Aboveground /above channel</b>	Canopy and stems	- shade controls in-stream temperature and primary production; - <b>source of large and fine plant detritus;</b> - <b>wildlife habitat.</b>
<b>In channel</b>	Large debris derived from riparian vegetation	- controls routing of water and sediment; - <b>shapes habitat: pools, riffles, runs;</b> - <b>provide cover.</b>
<b>Stream banks</b>	Roots	- increases bank stability; - <b>creates overhanging banks and cover;</b> - takes up nutrients from ground and stream water.
<b>Floodplain</b>	Stems and low-lying canopy	- retards movement of sediment, water and floated organic debris during floods.

**Blue-bold letters** indicate functions directly important for fish as a source of food (detritus) and creation of fish habitats and cover.

(after Swanson et al., 1982)



**BOX 11.7 (A)**  
The importance  
of shoreline structure for  
**upland river**  
fish communities

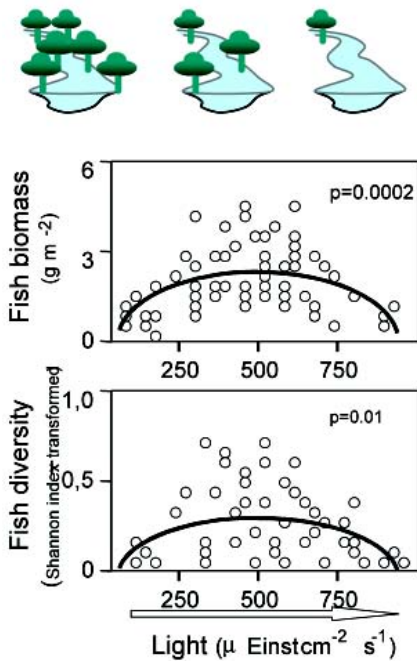

○ average annual values of fish biomass ( $\ln x + 1$ ) and diversity estimated for pool, run and riffle habitats

**BOX 11.7 (B)**  
The importance  
of shoreline structure for  
**lowland river**  
fish communities

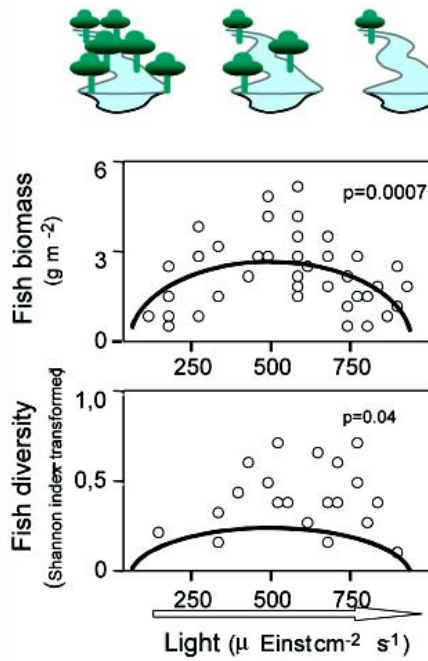

○ average annual values of fish biomass ( $\ln x + 1$ ) and diversity estimated for pool, run and riffle habitats

land rivers that the optimal complexity of riparian vegetation, for maintaining high fish biomass and diversity, is when the amount of light reaching the stream channel is between 300 to 700  $\mu E \text{ cm}^{-2} \text{ s}^{-1}$  (Zalewski et al., 2001; 2003). Fish biomass, and also diversity, in such habitats may be up to three times higher than in upland and lowland rivers receiving lower or maximal light inputs (Box 11.7 a,b).

**HOW CAN MANAGING RIVERBED STRUCTURE INCREASE FISH YIELDS?**

Fish species are characterized by high habitat preferences, thus their diversity and biomass is directly related to the presence of diversified habitats in river ecosystems (Box 11.8 a,b). For example, fish biomass and diversity estimated for small

sized rivers can be twice that of rivers high in riffles and pools than in more uniform run habitats, irrespective of the river type (Zalewski, 2002). River chenalization and regulation for uniform habitat in the form of continuous run stretches, and rehabilitation of meanders and pool-riffle sequences, are especially advised (see chapter 4.A).

**WHY IS RIVERBED STRUCTURE IMPORTANT FOR FISH?**

**Equilibrium of watercourses**

As water flows downstream from its source to the sea, much of its energy is spent overcoming the resistive forces of the valley floor: erosion dissipates energy. Material eroded from floodplains, riverbeds and banks is deposited as the underlying slope declines and the stream loses energy.

**BOX 11.8(A)**  
The importance  
of riverbed structure  
for upland river  
fish communities

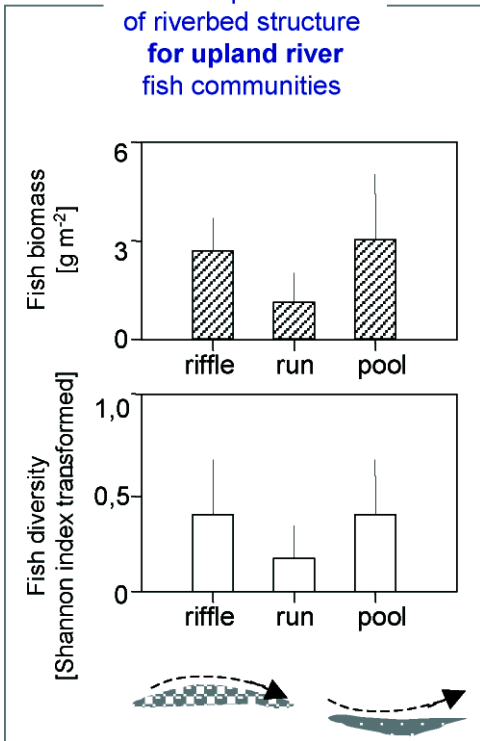

**BOX 11.8 (B)**  
The importance  
of riverbed structure  
for lowland river  
fish communities

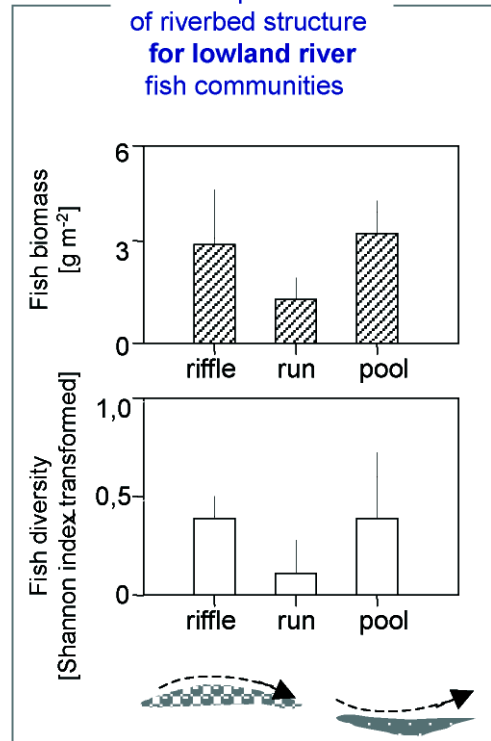

Heavier, coarser material is deposited first. Sediment gradually becomes finer downstream. Watercourses exist in a state of equilibrium (Box 11.9) with the surrounding environment, which

allows development of a variety of habitats, especially meanders, pools and riffles (Box 11.10), that are inhabited by riverine biota (e.g., macroinvertebrates, fish).

**BOX 11.9**  
River in equilibrium

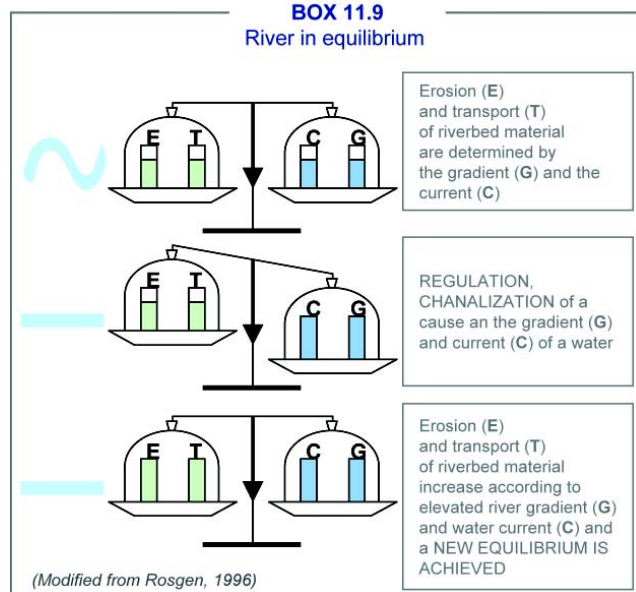

**BOX 11.10**  
**Basic river morphological structure:**  
**meanders and pool-riffle sequence**

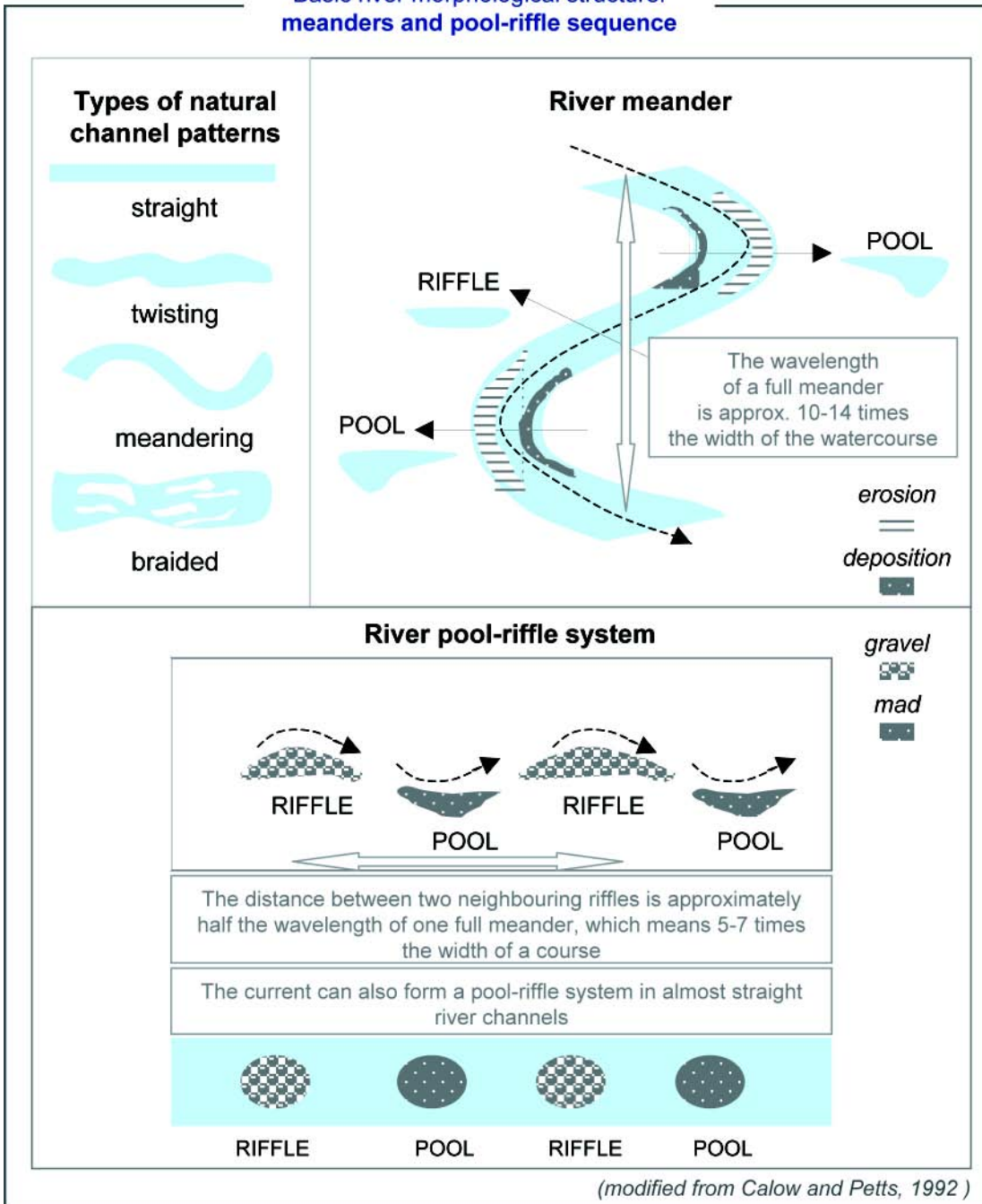

**MAKE SURE TO CHECK THESE RESOURCES:**

Guidelines: chapter 6

## ■ 11.D. ECOHYDROLOGICAL APPROACH IN POND AQUACULTURE

Sustainable management of aquaculture should be understood as the integral part of ecohydrological basin-scale management. It creates possibility not only for efficient fishery production, but also for improvement of water quality and quantity. Use of pond capacity for storage of water during high flow periods and its gradual release it into the river channel during low water flow allows to stabilize hydrological conditions of a river. It can be also applied for reduction of nutrient loads related to the hydro-peaking events (see chapter 10.C), while integrated with phytotechnologies. Adopting such an ecohydrological approach for pond aquaculture increases water and nutrient retention in watershed and enhance self-purification processes. It also support wild fish populations in rivers through shortening the low flow events.

### WHAT IS THE IMPACT OF POND AQUACULTURE ON NATURE RESOURCES?

Traditionally freshwater pond aquaculture usually contributes to water pollution through discharge of farm effluents and through the impact of cultured animals on wild communities. However, from the other point of view, if properly managed, ponds can be used as a tool for sustainable management of streams and rivers. Pond aquaculture can be used for enhancing riverine absorbing capacity through:

- ▶ increasing water retention in watersheds;
- ▶ enhancing nutrient transfer into food webs;
- ▶ creation of refuge areas for land-water plant and animal communities, thus increasing biodiversity of land-water communities; and
- ▶ surplus production of plants and animals for restoration purposes.

#### Improvement of the water cycle

Proper management of aquaculture production should be balanced with water resources availability. It should tend to adopt a production cycle that enables the reconciliation of water retention with production. Water gathered during wet seasons will be released to adjacent areas through infiltration and evaporation. This would positively influence the ground water level and mi-



Photo 11.4  
Aquaculture pond  
(photo: Z. Kaczkowski)

croclimate. Joining aquaculture with watershed-scale water retention and flood protection strategies could minimize the need for expensive engineering works, such as river regulation and reservoir construction. This would not only provide economic benefits through a reduced number of engineering investments, but also would be a mechanism limiting impacts on physical and biological components of river environments.

#### Decreasing nutrient enrichment

Nutrients transported into ponds by water supplies can be trapped in pond sediments and transferred into food webs. Thus, pollution is transformed into valuable aquaculture products.

*It has been shown that phosphorus retention is positively correlated with its rate of input into ponds. Mean inflow/outflow difference is about 0,07kg total phosphorus per hectare per year. (Knoeshe et al., 2003).*

#### Improving landscape values

Diversified patchy landscapes, which are provided by pond aquaculture, create high quality refuge areas for land-water plant and animal communities. This can cause problems for pond management (e.g., occurrence of protected animals such as beavers, otters and fish-eating birds) but also can be used for enhancement of the recreational

value of a given area. This in turn should increase local labour demand and provide additional income from recreation. Such simultaneous existence of a sustainable fishery and wildlife is possible when management scenarios, balanced between aquaculture production and nature protection needs, are created.

### Active protection of animals and plants

Aquaculture facilities can also be incorporated into active protection of animals and plants (see Guidelines, chapter 6). At present this is especially important for protecting heavily exploited fish stocks or stocks threatened with a disrupted recruitment cycle (e.g., lack of spawning habitats). Additional production of fish for stocking purposes can significantly increase the financial efficiency of production when compared to typical market production (e.g., polyculture of ide, *Leuciscus idus* L., with carp in Poland).

### WHAT PROBLEMS CAN BE EXPECTED?

The main problem is to reconcile the goal of aquaculture, production and income enhancement, with increased environmental awareness and watershed management needs. This means that achieving the sustainable ecohydrological development of aquaculture is possible only when producers are supported with scientific information and additional financial funds for investments are available. Such help should be provided by local or central governments and should be planned as a part of watershed protection scenarios. The most valuable help would be supporting the development of recreational attributes of a given facility. Some possibilities are commercial fisheries, places for bird watching, hunting and water sports.

### THREATS TO THE ENVIRONMENT

Unsustainable freshwater pond aquaculture can contribute to water pollution through discharge of fish farm effluents and the impact of cultured animals on wild communities. Usually the impact of wastewaters created by pond aquaculture is limited mostly to the period of drying and harvesting the fish. This pollution is related especially to the bottom layer of water (0 - 0,25 m above

the sediments), which takes on the quality of household sewage and mostly consists of suspended solids and different forms of nitrate and phosphorus. Wastewater quality can be specific to a given culture through introduced substances such as antibiotics, feeds and other chemical substances.

Other kinds of pollution connected with cultured animals that can threaten native communities are introduction of non-native species, genetic impacts on native populations or transfer of diseases and parasites. Escaped cultured animals can influence native populations also through predation and competition for food and space (see Guideline, chapter 6).

### HOW TO MITIGATE THE THREATS?

Fish farm effluents should be brought into areas covered by sedimentation pools and artificial wetlands (Box 11.11):

- ▶ the outflow of sediment can be regulated by flow speed. The threshold flow speed to minimize sediment outflow is **50 mm s<sup>-1</sup> (180 m h<sup>-1</sup>)** - Imhoff & Imhoff, 1982;
- ▶ specific weight of suspended solids for effluents from fishery facilities range between 1,00 and 1,20 N m<sup>-3</sup> (Karpinski, 1999). For very small flock solids the **flow limit is 72 mm h<sup>-1</sup>** (Table 11.6);
- ▶ fish faeces sedimentation reaches 90% if flow speed is **lower than 0,033 m s<sup>-1</sup>** (Jenssen, 1972). This process is more effective if effluents have low turbidity, which prevents crumbling of faecal flocks; and
- ▶ the best results for enhancing suspended solids retention are achieved if **water retention time is at its highest and the flow (V) at its lowest**. Estimation of these two values can be calculated from the following equation:

$$\text{Water Retention Time (h)} = \frac{\text{volume of sedimentary pool (m}^3\text{)}}{\text{flow (m}^3\text{h}^{-1}\text{)}}$$

where:

$V$  (m h<sup>-1</sup>) = flow (m<sup>3</sup> h<sup>-1</sup>) / transverse surface profile of the sedimentation pool (m<sup>2</sup>).

For example, to achieve good results, a well designed sediment pools for flow of 250 L s<sup>-1</sup> should cover an area of 1100 m<sup>2</sup> (Karpinski, 1999).

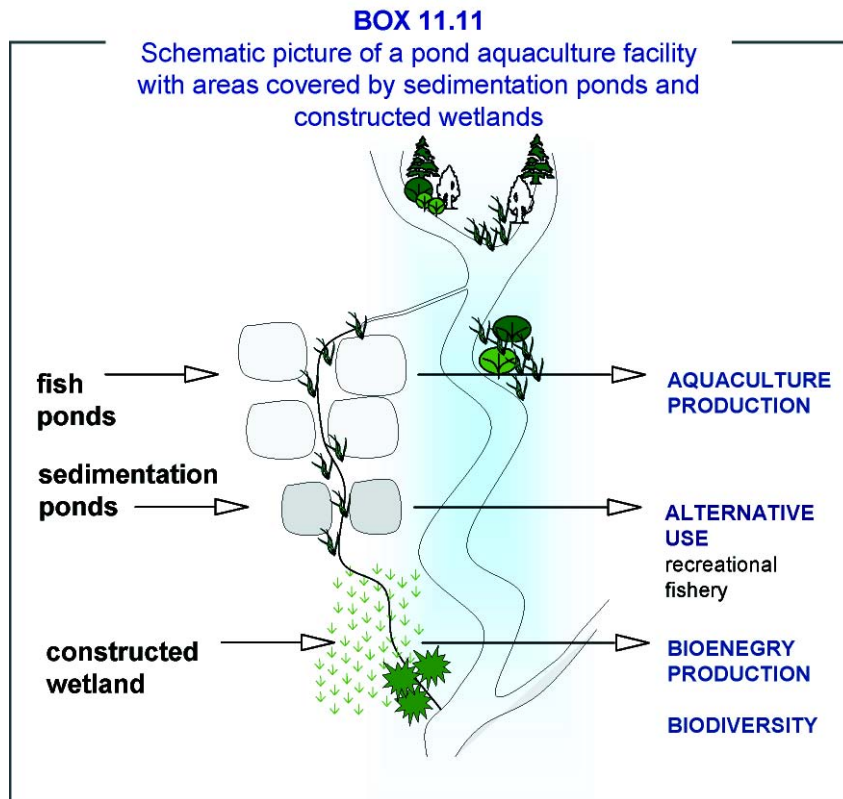

The quantity of contaminated water can also be reduced by proper construction of a pond (bottom slope). According Jeziarska-Madziar & Pinskiwar (1998), the total volume of contaminated water can be reduced from 24% to 2% of total water volume.

- ▶ very good results can be achieved by constructing wetlands on the water outflow from the ponds used for aquaculture. Constructed wetlands can reduce concentrations of **total phosphorus up to 50-90 % and total nitrogen up to 80%**;
- ▶ those biotechnological methods can be supported by technical solutions such as nets, sieves or microstainers. Nets and sieves used

on the outflow can reduce suspended material up to 50-70%.

**TOWARDS „ECOHYDROLOGICAL” AQUACULTURE**

The main problem that has to be resolved is reconciling **reasonable production** with **minimal impact on the environment**. One of the resolutions for the future can be creating **integrated intensive/extensive culture** systems (Varadi, 2003; Varadi & Bekefi, 2003). Such systems consist of **small-area intensive ponds** providing high yield of cultured animals and **large-area extensive ponds** (Box 11.12) - Fig. 11.5. An extended part of the facility can be adapted for purposes of re-

**TABLE 11.6**  
Sedimentation speed of granular suspensions ( $m\ h^{-1}$ ) of different size in sewage with a temperature of  $10^{\circ}C$

	PARTICLE DIAMETER (mm)						
	1,0	0,5	0,2	0,1	0,05	0,01	0,005
sand	502	258	82	24	6,1	0,3	0,06
household sewage	122	61	18	3	0,76	0,03	0,005

*(Imhoff & Imhoff, 1982, modified from Goryczko, 1999)*

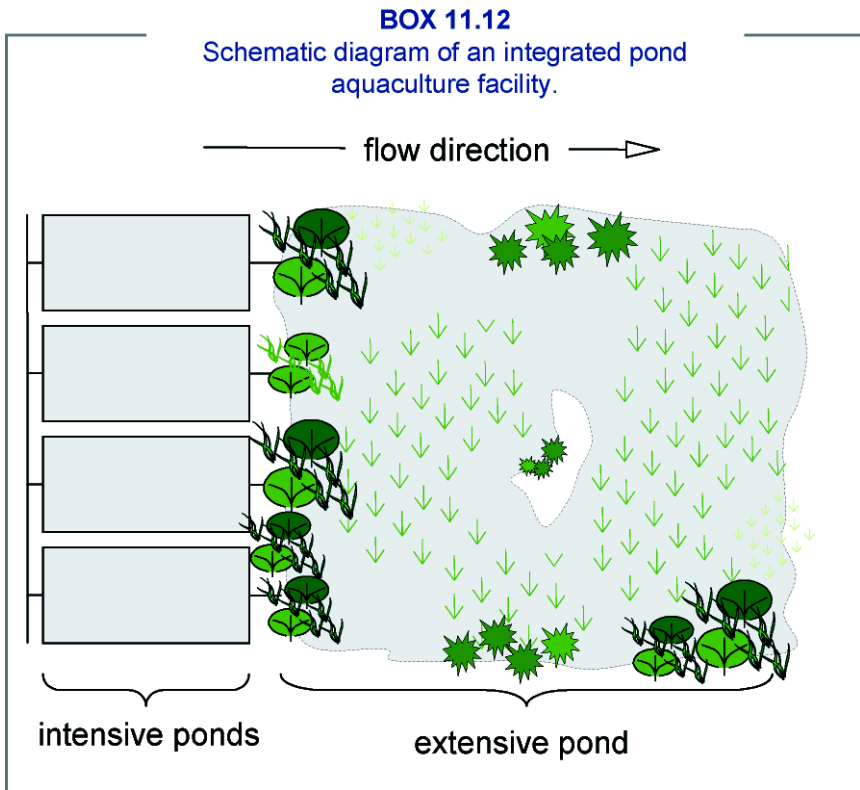

creation, recreational fishery and nature protection. Large-area extensive ponds can be replaced by considerably smaller area **constructed wetlands**. Removing macrophytes and shoreline vegetation can additionally increase nutrient retention in both types of ponds, enhancing their capacity for absorbing and reducing the effect of environmental impacts (Kerepeczki & Pekar, 2003).



Photo 11.5  
Extensive pond for reducing nutrient loads from aquaculture  
(photo: Z. Kaczowski)

## 12.A. ECOHYDROLOGICAL METHODS OF ALGAL BLOOM CONTROL

While management practices for upland reservoirs are usually focused on flood prevention, for lowland reservoirs located in middle or lower river reaches, eutrophication and toxic cyanobacterial blooms are usually the major problem. This is related to the conversion of large parts of lowlands to agricultural and urban areas. Lowland reservoirs are very vulnerable to human impacts because of their specific characteristics (see Chapter 3.G). Based on an understanding of the interplay between reservoir hydrology and biotic dynamics, ecohydrology provides methods for both reducing eutrophication, as well as controlling the appearance of its symptoms.

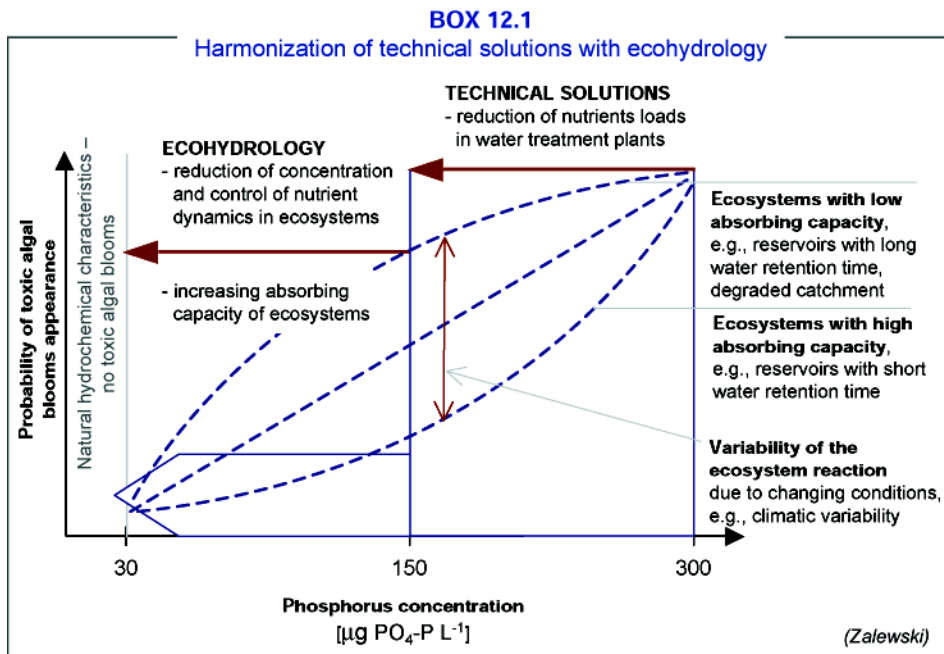

Fig. 12.1  
Toxic cyanobacterial bloom in the water intake, the Sulejow Reservoir, Poland, September 1999  
(photo: M. Tarczynska)

### ELIMINATION OF THREATS - REDUCTION OF CATCHMENT IMPACTS

Understanding the limited capacity of lowland reservoirs for pollutants is important in developing a successful strategy for reducing eutrophication and toxic algal blooms. In a case of European rivers, the average phosphorus concentration is  $300 \text{ mg L}^{-1}$ , which creates risk of toxic algal blooms in lowland dam reservoirs. In order to reduce the concentration to the safe level of  $30 \text{ mg L}^{-1}$ , application of technical solutions only is not sufficient. The strategy should be based on the **harmonization of technical and ecological solutions**

(Box 12.1), which allows the required level of water quality to be reached. The first, necessary step before the application of ecohydrological measures, is always the **elimination of threats**, such as reduction of point sources of pollution (see chapters 4.A, 4.B, 10.A), as well as non-point sources (see chapters 9.A, 9.B, 9.C, 10.B, 10.C) from both direct and indirect catchments. Point sources of pollution include not only direct outflows from farms, industries or cities. Sewage treatment plants should also be considered as a potential threat, since nutrient concentrations in the treated water are often too high compared to the





**BOX 12.2**

**Proper and improper decisions on sewage treatment plant location**

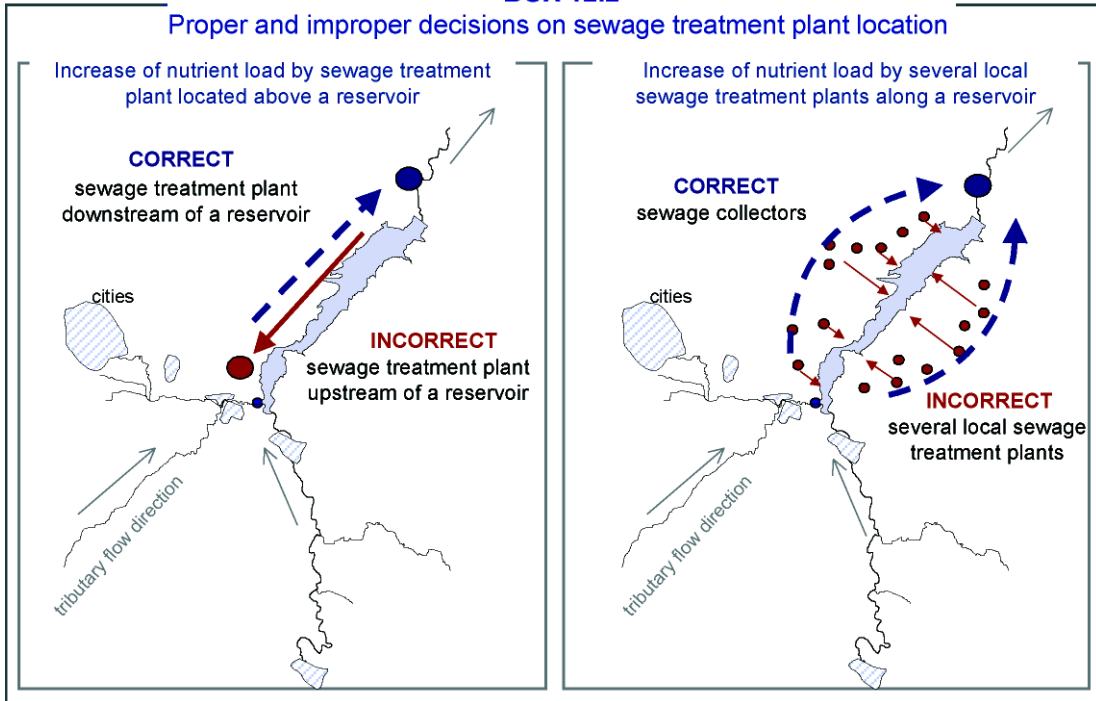

**BOX 12.3**

**Enhancement of sedimentation and phosphorus trapping in the inflow to a reservoir**

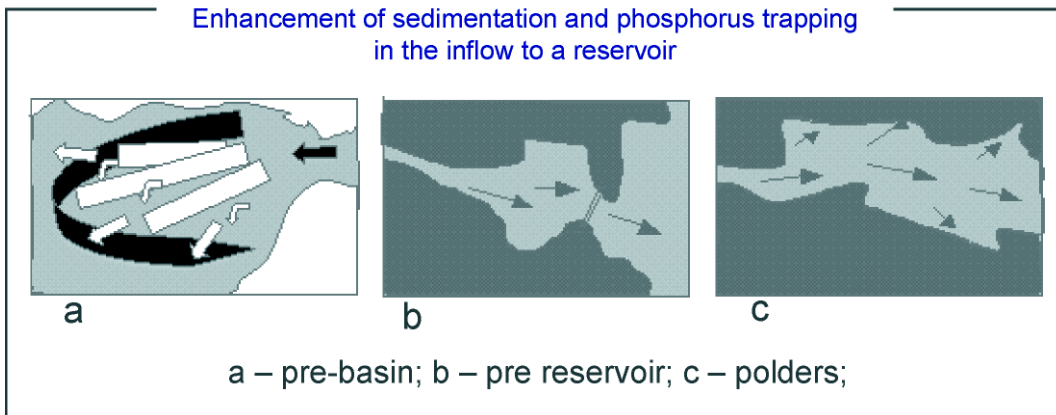

natural hydrochemical characteristics of surface waters. Box 12.2 shows examples of correct and incorrect locations for water treatment plants in relation to a reservoir.

**GENERAL RECOMMENDATIONS FOR A ECOHYDROLOGICAL APPROACH TO RESERVOIR MANAGEMENT**

Ecohydrological control of eutrophication symptoms (understood as appearance of high phytoplankton biomass) in reservoirs, is based on an understanding of the **relationship between hydrological properties**

of a reservoir on the one hand, and **biotic dynamics**, on the other. The major processes responsible for phytoplankton biomass appearance that can to a certain extent be regulated by ecohydrological practices in a reservoir include:

- ▶ reduction of **external nutrient inflow**;
- ▶ control of **water retention time** and **stability of a water column**; and
- ▶ reduction of **internal load**.

### Reduction of nutrient inflow by regulation of reservoir hydraulics

Integrated management of an upstream catchment is always necessary for reduction of the external nutrient supply. Reducing nutrient export by landscapes (see chapter 9) and land-water interface management (see chapter 10) can, however, be complemented with several methods applied in the mouth of tributaries and upper sections of reservoirs. Most of them are based on modification of tributaries (see chapter 10.C) or reservoir hydraulics in order to intensify retention of transported materials. Among the latter, the following systems are the most commonly used (Box 12.3):

- ▶ **Pre-basin systems** involving a system of curtains, which reduces the energy of inflowing water. This kind of solution allows heavy materials transported by rivers to settle in the inlet of a reservoir. The system requires periodic removal of the settled material in order to prevent internal load (Box 12.3 a).
- ▶ **Pre-reservoir systems** that involve the use of a smaller weir upstream of a reservoir can eliminate up to 90% of a phosphorus load if the critical retention time is maximized. Periodic removal of the sediments from a pre-reservoir is also required (Twinch & Grobler, 1986) (Box 12.3 b).
- ▶ **Sedimentation polders** - located on a river above an inflow to a reservoir (see chapter 5.C). Application of seasonally harvested vegetation may enhance sedimentation of suspended material and uptake of dissolved nutrients in these areas (Box 12.3).
- ▶ **Riparian wetland systems** that involve the protection or reconstruction of ecotones with an intermediate degree of complexity upstream of a reservoir. Application of macrophytes and wetland vegetation resistant to water level fluctuations may also be helpful in controlling non-point sources of pollution from a direct catchment of a reservoir. Additionally, vegetation stabilizes sediments, preventing their resuspension.

### Control of water retention time (WRT)

Long water retention time (WRT) is one of the most important factors in reservoirs which can lead to cyanobacterial bloom formation. Shortening WRT during periods when cyanobacterial blooms are expected efficiently reduces their appearance. Extension of WRT to over 60 days usually leads to formation of high cyanobacterial biomass (Box 12.4).

If water retention times are decreased in a reservoir, the following processes can be expected:

- ▶ increased water column mixing;
- ▶ decreased epilimnetic water temperature; and
- ▶ increased oxygenation, especially in the bottom waters of a reservoir.

These hydrological factors can be used as a management tool in many reservoirs, especially in cascades or multiple reservoir systems.

**In through-flow reservoirs** the growth of phytoplankton will be limited by strong mixing as a result of intensive water exchange and short water residence times. Even high concentrations of nutrients will not yield any appreciable biological effects. The algal flora will be restricted to those small, fast-growing and invasive species such as flagellates, green algae, and diatoms.

- ▶ regulation of WRT in **medium-sized reservoirs** is usually a complicated, often impossible task and should therefore be carefully considered in the construction of new reservoirs. In order to eliminate the occurrence of cyanobacterial blooms, it is recommended that the volume of a reservoir should be adjusted to the amount of inflowing water from supply rivers so that the reservoir's WRT does not exceed 30 days;
- ▶ in the case of reservoirs with **long water retention times**, special attention should be given to protection and proper management practices in the catchment area (Box 12.4).

### Stability of the water column

One of the conditions favouring cyanobacterial development is stability of the water column. Destabilization of a reservoir usually prevents vertical migration of cyanobacteria and reduces cell

growth. Therefore, enhancing turbulence within the reservoir may limit both formation and accumulation of cyanobacterial blooms.

Turbulence can be achieved by:

- ▶ decreasing water retention time;
- ▶ increasing flow; and
- ▶ maximizing turbulence created by the wind.

The above effects can be applied at the stage of **reservoir planning** by:

- ▶ orienting the reservoir to maximize **turbulence created by the wind**; and
- ▶ diversifying **lake morphometry** (Box 12.5).

### How to increase turbulence and water flow in a reservoir

The diversified morphometry of a reservoir means that flow is not constant throughout a system, although water retention time is the same. Natural or artificial barriers such as a series of islands or

peninsulas create increased flow. During high flow, the turbulence caused by the flow is often strong enough to mix the entire water column. Intensively mixing water limits the growth of cyanobacteria. Under these conditions the algal flora will be restricted to species that are able to grow in strongly mixing conditions (Box 12.5).

### Wind influence

It is assumed that wind speed above  $3 \text{ m s}^{-1}$  generates turbulence in the water, which prevents blooms from forming (Oliver & Ganf, 2000). This factor should also be considered in the construction of new reservoirs. It can be achieved by orienting the reservoir to maximize turbulence created by the wind, thereby disadvantaging buoyant cyanobacteria, or by utilizing the prevailing wind conditions to drive the blooms away from drinking water intakes, especially during those months when intensive blooms may be expected to occur (Tarczynska et al., 2001) - Box 12.6

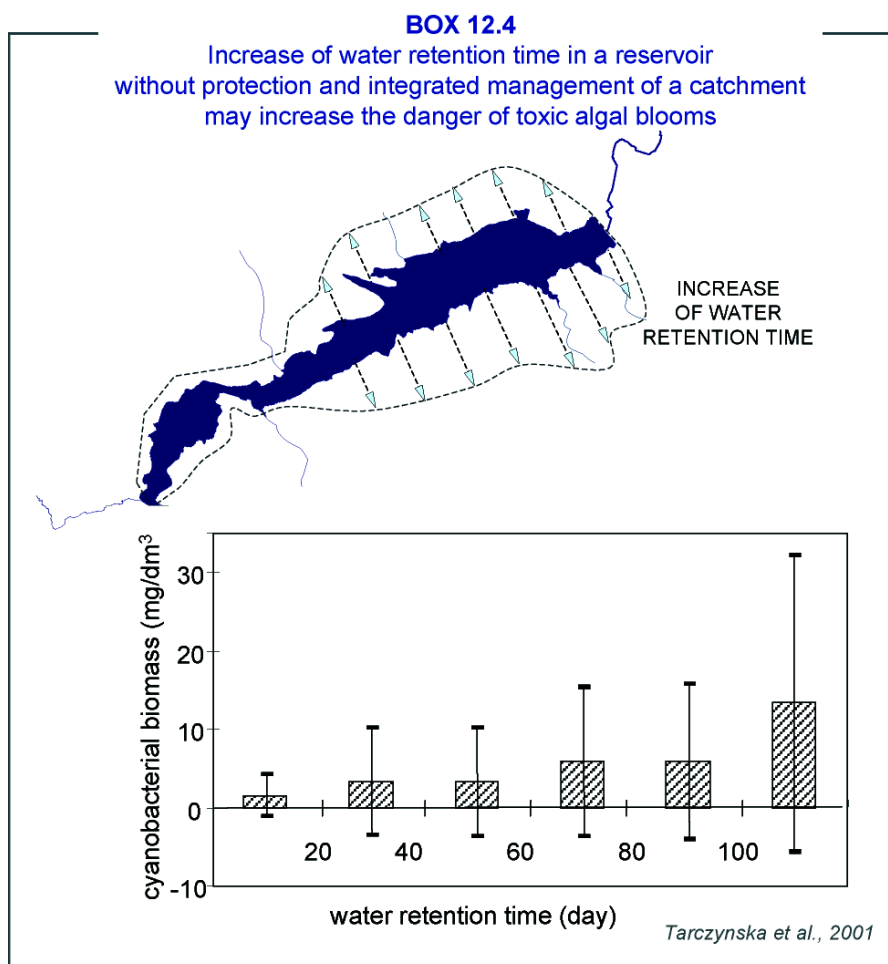

**ARE TOXINS REMOVED DURING DRINKING WATER PURIFICATION PROCESSES?**

Cyanotoxins are chemically very stable and can not be decomposed by acid, alkali or boiling (Harada, 1996). Also in field conditions their degradation is minimal. They are difficult to deactivate during water treatment processes (Chorus & Bartram, 1999).

Cyanobacterial toxins represent a challenge to drinking water treatment, which involves removal of organic substances in both soluble and insoluble forms.

Several drinking water treatment processes are classified into three types: coagulation-filtration, oxidation with oxidants such as chlorine and ozone and adsorption with activated carbon (Harada, 2000). A conventional water treatment process is shown in Box 12.7.

nologies (membranes, air flocculation), have been reported. Appendix 9 summarizes treatment processes and removal of microcystins from contaminated water. The final step in controlling cyanobacteria and their toxins is the drinking water treatment process. Although conventional water treatment processes using coagulation, clarification and filtration are effective in removing cyanobacterial cells (Jones, 1996), these same conventional water treatment processes are only partially successful in removing cyanobacterial toxins. Good control technology must reflect proper management of the watershed and reservoir to prevent algal and cyanobacterial growth, and requires an appropriate monitoring program. In the event that blooms do develop, an appropriate treatment technology for both the cyanobacteria and their toxins will be required (Chorus, 2001).

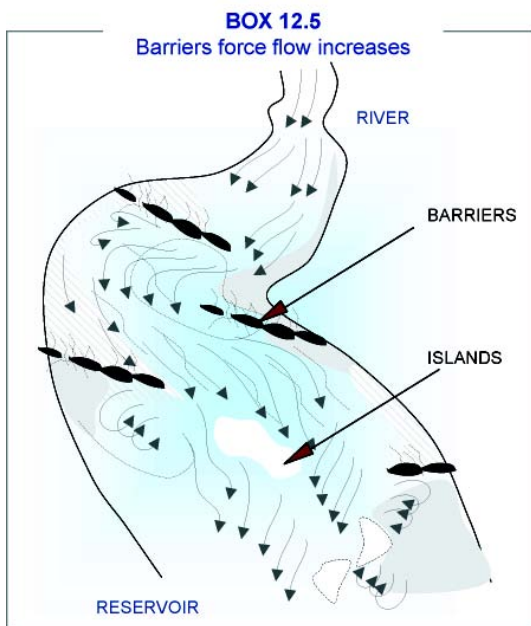

The treatment objective is effective elimination of extra- and intracellular cyanotoxins by adequate technology and sequential treatment stages to minimize cyanotoxin release during water treatment. The application of conventional (pre-oxidation, flocculation), polishing (inter-oxidation, GAC/-BAC adsorption) and final treatment (disinfection, distribution), as well as alternative tech-

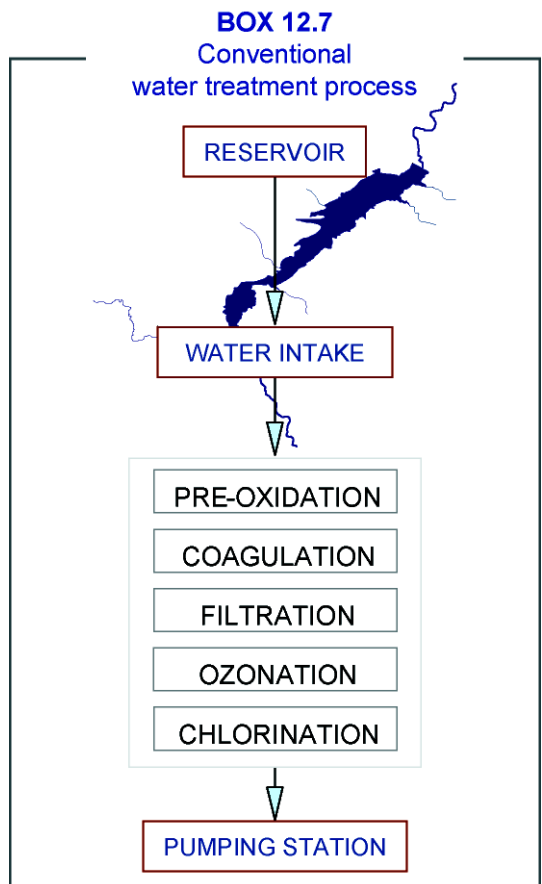

**BOX 12.6**

**Incorrect location of a drinking water intake**

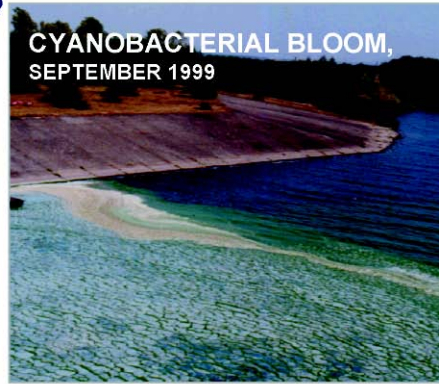
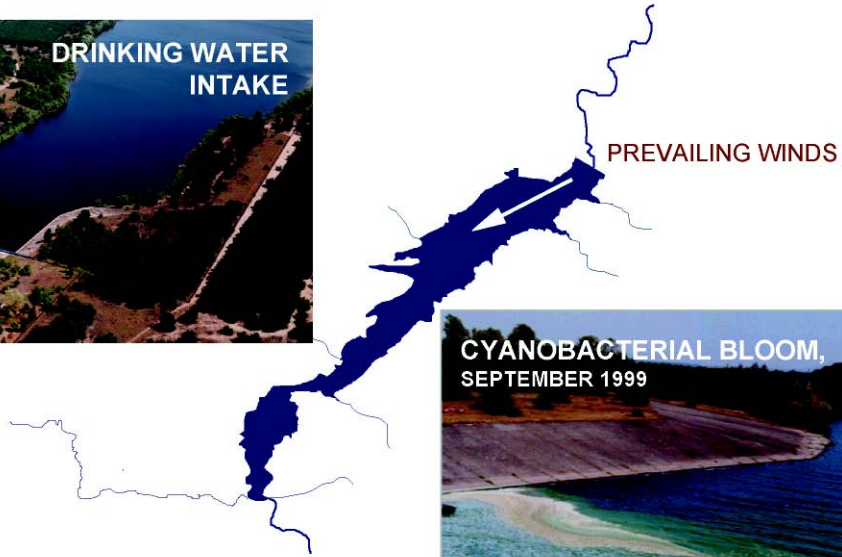
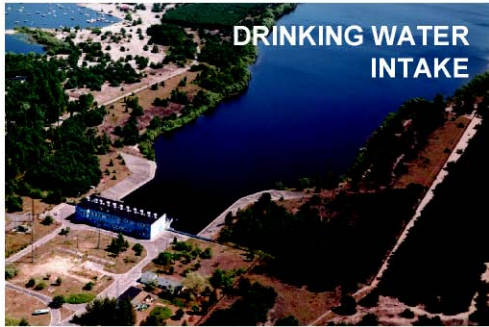

the prevailing wind transports blooms to the bay containing the drinking water intake  
*(the Sulejow Reservoir, Poland)*

*(photo: M. Tarczyska)*

**MAKE SURE TO CHECK THESE RESOURCES:**

Guidelines: chapters 6, 7

## ■ 12.B. HOW TO MANAGE BIOTIC STRUCTURE IN A RESERVOIR

Progressing eutrophication of inland waters leads frequently towards appearance of such symptoms as intensive algal blooms, including blooms of toxic cyanobacteria. In water bodies where the external nutrient load has been previously reduced, and the phosphorus concentrations are relatively low, the most economic way of reducing eutrophication symptoms is implementation of biological methods based on manipulation of the biotic structure of an ecosystem. The objective of this chapter is to present biomanipulation methods to reduce and prevent the appearance of high algal biomass in man-made reservoirs.

### WHAT IS BIOMANIPULATION AND WHERE CAN WE USE IT?

Biomanipulation methods are based on establishing the most profitable, from the point of view of water quality, **biotic structure of an ecosystem** (Shapiro et al., 1975) - Box 12.8. To achieve this goal, biomanipulation should be adjusted to specific conditions that control functioning of a given ecosystem. Nevertheless, there are some basic relationships and mechanisms influencing, directly or indirectly, development of phytoplankton and are of great importance in controlling their blooms.

Biomanipulation methods can be applied in water bodies where the **total phosphorus concentration during spring turnover does not exceed 100-150  $\mu\text{g L}^{-1}$** . In these ecosystems, biomanipulation is an economic way to reduce eutrophication symptoms while the total amount of phosphorus in a reservoir or lake does not change. It is based on allocating nutrients from the pool available for algal primary production to the unavailable pool.

### HOW TO MANIPULATE THE BIOTIC STRUCTURE OF AN ECOSYSTEM

The classic „biomanipulation“ approach is based on increasing **predatory fish abundance (up to 30-40% of the entire fish community)**. Their pressure on zooplanktivorous fish promotes population development of large cladocerans in the water column, which by effective filtration are able to control algal abundance. Thus, biomanipulation utilizes the phenomenon of cascading effects



Fig. 12.2  
Biomanipulation can be an economic way to reduce eutrophication symptoms (photo: Z. Kaczkowski)

(„top-down“ effect), which depends on transmission of changes within given trophic levels to lower ones (Carpenter et al., 1985; McQueen et al., 1986; also see chapter 7.B).

### HOW IS THE TROPHIC STRUCTURE OF AN ECOSYSTEM CONTROLLED?

Domination of large forms of zooplankton result in increasing water transparency and may be achieved by:

- ▶ complete **removal of fish** from water bodies (only in the case of drinking water reservoirs closed for fishery and angling activities);
- ▶ **introduction of new, or reinforcement of, existing populations of predatory fish** (unless planktivorous fish are dominated by deep-bodied species resistant to predation). In the temperate zone stocking with fingerlings of both pelagic (pikeperch) and littoral (pike) predators at between 500-1000 individuals per ha, is recommended. To avoid mutual predation the area of stocking of these two species should be separate;
- ▶ **reduction of the abundance of zooplanktivorous fish** by:
  - intensive **fishing of adult fish** (biomass of all non-predatory fish should be maintained **below 50 kg ha<sup>-1</sup>**);
  - **collecting excessive numbers of juvenile fish** from the littoral zone (their density should not exceed **5 specimens per squ-**

**BOX 12.8**

What should the biotic structure of an ecosystem be to maintain water quality?

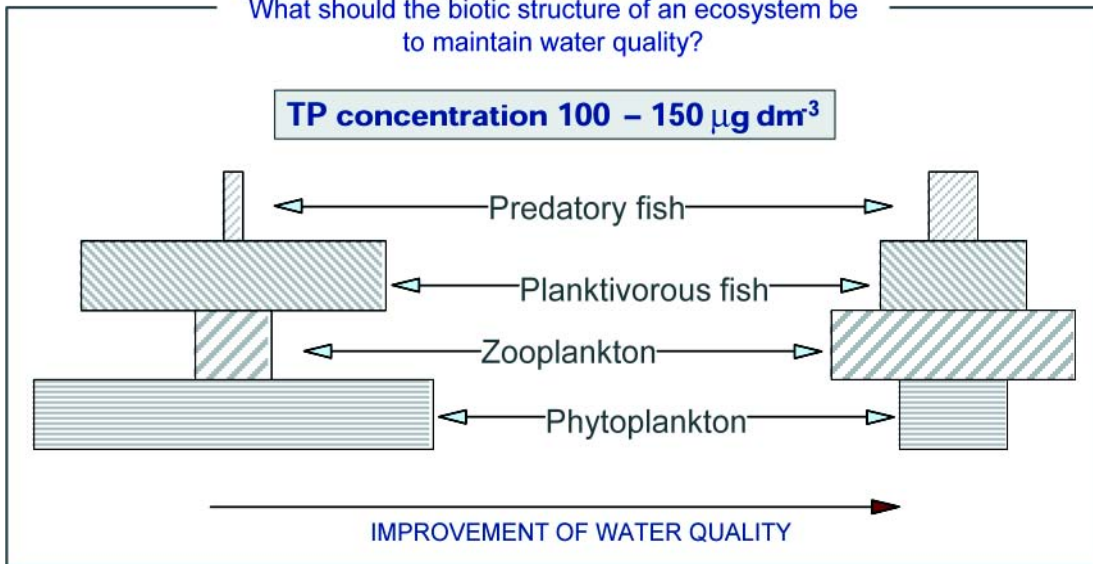

are metre) and transfer them to ponds or lakes as stocking material; and

- **controlling fish spawning** success by water level manipulation and/or by using species-specific spawning substrates.

**HOW TO STRENGTHEN THE EFFECTS**

To strengthen the „top down“ forces leading to the reduction of the intensity of algae blooms, it is also necessary to diminish „bottom-up“ effects, which come from the water ecosystem supplying nutrients. This may be achieved by:

- ▶ the first necessary step is always **reduction of nutrient supply** from a catchment area, by implementing IWM, including elimination of point sources of pollution and reduction of non-point sources supported by application of ecohydrological and phytotechnological measures;
- ▶ intensive **fishing of omnivorous and herbivorous species**, which stimulate algal development by providing them with easily available nutrients;
- ▶ **dredging organic sediments** (after the summer) from areas of intense accumulation in order to diminish internal loading of nutrients. The sediments may be used as fertilisers in agriculture, if no heavy metals are present;

- ▶ **introducing zebra mussels**, which filter seston and block nutrients in biomass. They are also able to consolidate loose bottom substratum, protecting sediment from resuspension. This method is not recommended in water bodies containing many hydro-engineering devices, which are quickly colonized and clogged by this mussel;
- ▶ **creation of sedimentation zones with macrophytes** in backwaters of reservoirs in order to reduce nutrient loads transported from the catchment during floods; and
- ▶ **creation of riparian buffering zones** along shorelines and appropriate planning of tourist infrastructure in order to reduce nutrients load from a direct catchment.

**ROLE OF MACROPHYTES IN CONTROLLING BIOTIC STRUCTURE**

Special emphases should be put on the role of macrophytes in restoring and maintaining a clear water state (Box 12.9). Macrophytes should be encouraged to grow in transparent, shallow and not very large water bodies where the **total phosphorus concentration exceeds 100  $\mu\text{g L}^{-1}$**  and an exclusive use of the classic method of biomani-pulation is usually not sufficient for improving water quality (Fig. 12.2).

These effects are realized via direct and indirect impacts of littoral macrophytes on the dynamics of phytoplankton, zooplankton and fish populations:

- ▶ aquatic macrophytes can **negatively influence planktonic algae** - phytoplankton may suffer from a competition for nutrients, shading and allelopathy;
- ▶ macrophytes can **decrease the amount of nutrients** available to phytoplankton by reducing water movement and thus sediment resuspension;
- ▶ some plants can **oxidize the sediment surface**, preventing phosphorus from being released to the water column;
- ▶ beds of macrophytes **positively affect zooplankton** providing them both shelter and diverse food.
- ▶ macrophytes in the littoral zone serve as refuges and/or foraging grounds, as well as spawning substrates and nursery areas for most **fish species**;
- ▶ the type and density of vegetation in the littoral zone and temporarily flooded terrestrial areas influence to a great extent both **fish species composition and their abundance**;
- ▶ occurrence of littoral macrophytes decides the density of typical ambush **predators** such as pike, *Esox lucius*, greatly affecting their foraging and spawning success;
- ▶ macrophytes not only serve as the substratum for egg attachment, but their presence also diminishes egg mortality, protecting them against wind and wave action and siltation;
- ▶ macrophytes can be removed from an ecosystem, thereby also removing phosphorus and nitrogen (see chapter 12.C).

**BOX 12.9**

General relationship between turbidity, nutrient concentrations and presence of macrophytes

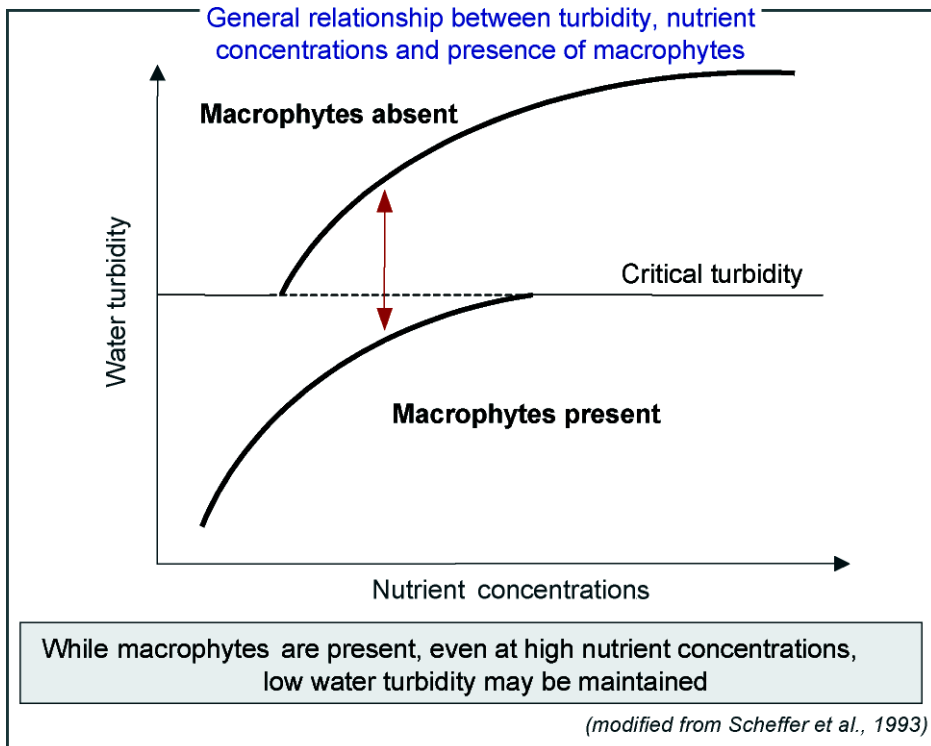

**MAKE SURE TO CHECK THESE RESOURCES:**

Guidelines: chapter 8.C



## 12.C. HARVESTING MACROPHYTES AND MACROALGAE

Macrophytes and macroalgae cultivated in eutrophic lakes and reservoirs, and also in streams and rivers, are an important and effective pathway of nutrient removal from waters and bottom sediments. Nutrients are obtained from available pools and assimilated into the biomass of macrophytes and macroalgae. In some situations, therefore, they may help to restrict phytoplankton growth. In order to increase nutrient removal efficiency and prevent their release back to the water during autumn in temperate regions, it is necessary to seasonally harvest and remove plants from ecosystems.

### WHERE CAN HARVESTING BE APPLIED?

Harvesting macrophytes and macroalgae by uprooting and removing them has been widely used in streams and also, to a certain extent, in reservoirs, where they have caused problems in turbines. This method can, in principle, be used wherever macrophytes or macroalgae are a significant result of eutrophication. At least a mass balance, but even better an eutrophication model, should be constructed to evaluate the significance of the method compared with other methods or as a supplement to other methods.

### WHAT AMOUNT OF NUTRIENTS CAN BE REMOVED?

The removal of nutrients by harvesting will, of course, correspond to the amount of nutrients in the harvested plants, which is - **on a dry matter basis** - in the order of:

- ▶ **5-8% for nitrogen;**
- ▶ **0,5-1,2% for phosphorus.**

If a significant area of a lake or reservoir is covered by macrophytes or macroalgae, it will be a significant amount of nutrients that will be removed by this method. If only the littoral zone contains plants, it may be a small nutrient removal compared with the costs.

The total removal can be found by the following two equations:

$$RN=0,065 MP AC/100 A \text{ (kg N/harvest)}$$

$$RP=0,0085 MP AC/100A \text{ (kg P/harvest)}$$



Fig. 12.3  
Removing macrophytes from  
Lake Biwa, Japan  
(photo: V. Santiago-Fandino)

Where:

RN - Nitrogen removal [kgN/harvest]

RP - Phosphorus removal [kgP/harvest]

0.065 and 0.0085, respectively, are the average concentrations of N and P in plants on a dry matter basis.

MP - the average dry matter mass of plants per m<sup>2</sup>

AC - the coverage of plants [%].

A - the lake or reservoir area in [m<sup>2</sup>].

A simultaneous removal of nutrients from inflowing effluents, if they are point sources, should also be considered to ensure a long-term effect of the harvesting method.

### HOW CAN REMOVED PLANTS BE UTILIZED?

Aquatic plants can be used in several ways, the most common include:

- ▶ animal feeds;
- ▶ soil additives;
- ▶ pulp and paper production;
- ▶ production of chemicals applicable for medicine production; and
- ▶ energy sources.

All the above uses can also be applied to plants removed from constructed and natural wetlands. The productivity of emergent plants is higher than that of terrestrial communities and agricultural crops because they:

- ▶ have optimal conditions for growth, and do not suffer from water shortages.

- ▶ have high tolerances for fluctuations in environmental conditions.
- ▶ have high photosynthetic efficiencies.

#### Animal feeds

A problem with the use of aquatic plants as animal feed is the high moisture content, which causes difficulties in processing, transportation and storage. The process of silaging might become very important in humid tropical and subtropical regions where it is difficult to sun-dry the plants due to rapid spoilage.

The method has been used to restore, at least partially, several **Chinese lakes** where the harvested plants were utilized as pig feed. Utilization of harvested plants as **feed for domestic animals** requires a careful examination of the contamination of the lake or reservoir by toxic substances, as they may have bio-accumulated in the harvested plants.

#### Energy sources

If it is not recommended to utilize the plants as feed for domestic animals instead the plants may be **incinerated**. As the plants have a dry matter content of only 10-20%, the amount of energy, which can be recovered by their incineration is

very modest. Sun drying before incineration is recommended in countries with a warm climate.

#### Soil additives

Plants can be turned into soil additives either in the form of mulch and organic fertilizers or by burning the plants to form ash or using them to make compost. For composting a moisture content of 50 - 70% is required. The relatively high nutrient content in emergent macrophytes favours microbes that produce compost. This method is mostly used, however, for plants removed from constructed wetlands (such as water hyacinth and reeds), where they can be mixed with, e.g., de-watered sludge.

#### Pulp, paper and fibre

Due to their relatively high crude fibre and cellulose contents, common reeds (*Phragmites*) and cattails can be used as a source of paper pulp and fibre. In Romania, reeds were converted into pulp to make **printing paper, cellophane, cardboard** and other products such as cemented reed blocks and compressed fibreboard, furfural, alcohol and fuel, insulation material and fertilizer (Poh-eng & Polprasert, 1996)

#### MAKE SURE TO CHECK THESE RESOURCES:

<http://www.waste.nl/docpdf/WD10.pdf>

<http://www.unep.or.jp/ietc/Publications/Freshwater/FMS7/index.asp>

## 12.D. OTHER METHODS OF WATER QUALITY IMPROVEMENT

### REMOVAL OF SUPERFICIAL SEDIMENT

Removal of superficial sediment can be used to support the recovery process of very eutrophic lakes and areas contaminated by toxic substances. This method can only be applied with great care in small ecosystems. Sediments in eutrophic systems have high nutrient concentrations and potentially can accumulate many toxic substances, including heavy metals. If a wastewater treatment scheme is initiated, storage of nutrients and toxic substances in the sediment might prevent recovery of the ecosystem due to exchange processes between the sediment and water. Anaerobic conditions, which are often present in the sediment of eutrophic lakes, might even accelerate these exchange processes. This is often observed for phosphorus, as iron(III) phosphate reacts with sulphide and forms iron(II)-sulphide by releasing phosphate. The amount of pollutants stored in sediment is often very significant, depending on the discharge of untreated wastewater prior to the introduction of a treatment scheme. Thus, even though the retention time of the water is moderate, it might still take a very long time for an ecosystem to recover.

The removal of bottom sediment can be done mechanically or by use of pneumatic methods. These methods are, however, generally very costly to implement and have therefore been limited

in use to smaller systems. The best known case of removal of superficial sediment is Lake Trummen in Sweden, where 40 cm of the superficial sediment were removed.

Removed sediment can be applied as soil conditioner if it has a high content of nutrients and only minor concentrations of possibly toxic substances. If concentration of toxic substances in sediment is too high to be used as a soil conditioner, it has to be used as landfill or it is necessary to incinerate it. For example in Denmark, standards used for sediment, sludge or compost that can be utilized as soil conditioner are relatively strict, which is showed in the Table 12.1.

The transparency of Lake Trummen was improved considerably, but decreased again due to phosphorus in overflows from rainwater basins. Probably treatment of the overflow after superficial sediment removal would have given a better result. This example shows why it is recommended to set up a mass balance or, even better, a model to have a full overview of all the sources of nutrients or toxic substances.

### SEDIMENT COVERAGE

Covering sediments with an inert material is an alternative to removing superficial sediment. The idea is to prevent the exchange of nutrients (or maybe toxic substances) between the sediment

**TABLE 12.1**  
Maximum concentrations for compounds in sludge applied in Denmark  
as soil conditioner in agriculture

COMPOUND	Max. conc. [mg kg <sup>-1</sup> of d. w.]	EC- 50% repr. reduct. spring- tails [mg kg <sup>-1</sup> of soil d.w.]	Range 1997-1998 found in DK [mg kg <sup>-1</sup> of d. w.]
Cd	0,8	50	0,2 – 4,0
Cr	100		11- 230
Cu	1000 (aver. conc. about 30)	130	8 - 89
Pb	120	2800	17 - 345
Hg	0.8		0.1-0.9
Ni	30	450	4 - 145
Zn	4000 (aver. conc. about 200)	700	
LAS	1300	740	11 – 160 000
DEHP	50	> 5000	4 - 170
PAHs	3		
Nonylphenol	10	44	0,3 - 67

and water. Polyethylene, polypropylene, fibreglass screen or clay are used to cover the sediment surface. The general applicability of the method is limited due to the high costs, even though it might be more moderate in cost than removal of superficial sediment. It has only been used in a few cases and a more general evaluation of the method is still needed.

**SIPHONING OF HYPOLIMNETIC WATER**

Siphoning of hypolimnetic water is more moderate in cost than the two methods mentioned above. It can be used over a longer period and thereby gives a pronounced overall effect. The method is intended to reduce the significant nutrient concentration differences between an epilimnion and hypolimnion, which is often the case in lakes or reservoirs with a pronounced thermocline. The hypolimnetic concentration during water column stratification is often several times greater than the concentration in the epilimnion. This implies that the method will only have an effect during the period of the year when a thermocline is present (in many temperate lakes from May to October/November). However, as the hypolimnetic water can have nutrient concentrations 5-times or more greater than the epilimnetic water, it might have a significant influence on the nutrient budget to apply the method even when a thermocline is absent.

As the hypolimnetic water is colder and poorer in oxygen, the thermocline can descend under strong wind activity thereby reducing the anaerobic zone. This will transport nutrients from the entrained part of the hypolimnion into the epilimnion and will also reduce the total hypolimnetic nutrient pool because its volume will have been reduced. If there are lakes or reservoirs downstream, the method cannot be used, as it only removes, but does not solve the problem. A possibility in such cases would be to remove phosphorus from the hypolimnetic water before it is discharged downstream. The low concentration of phosphorus in hypolimnetic water (maybe 0.5 - 1.5 mg L<sup>-1</sup>) compared with wastewaters, makes it almost impossible to apply chemical precipitation. However, it will be feasible to use ion exchange because the capacity of an ion exchanger is more dependent on the total amount of phosphorus removed and the flow than on the total volume of water treated. Box 12.10 illustrates the use of siphoning and ion exchange of hypolimnetic water.

Several lakes have been restored by this method, mainly in Austria, Slovenia and Switzerland with significant decreases of the phosphorus concentration. Generally, the decline in total phosphorus concentration in an epilimnion is proportional to the amount of total phosphorus removed by siphoning and the length of time the process has been used.

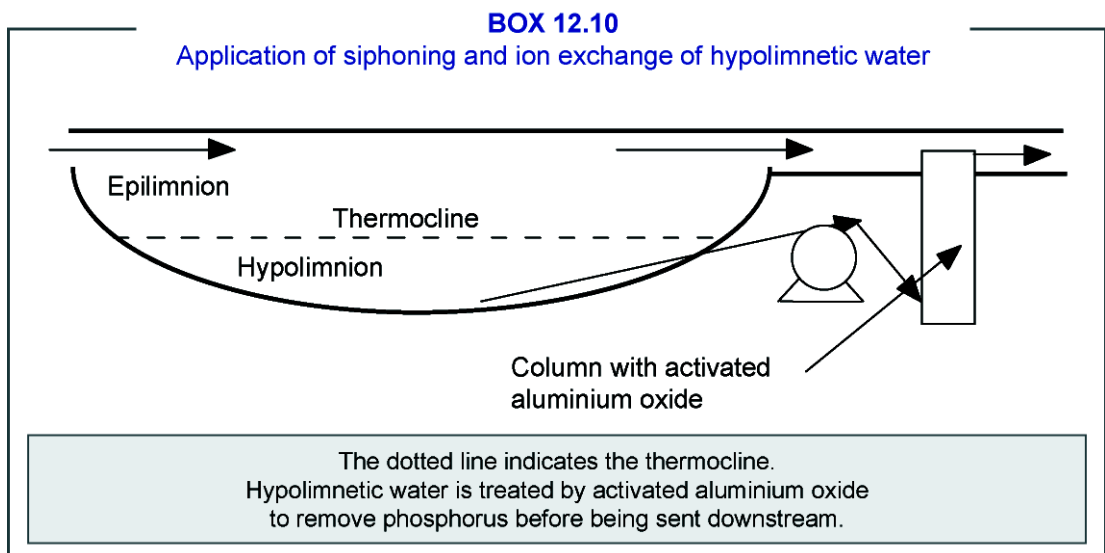

The method has relatively low costs and is relatively effective, but the phosphorus must, of course, be removed from hypolimnetic water before it is discharged if there are other lakes downstream.

### FLOCCULATION

Flocculation of phosphorus in a lake or reservoir is another alternative. Either aluminium sulphate or iron(III)-chloride can be used. Calcium hydroxide cannot be used, even though it is an excellent precipitant for wastewater, as its effect is pH-dependent and a pH of 9.5 or higher is required. The method is not generally recommended as:

- ▶ it is not certain that all flocs will settle and thereby incorporate the phosphorus in the sediment; and
- ▶ the phosphorus might be released from the sediment again at a later stage.

### AERATION

Aeration of lakes and reservoirs is a more direct method to prevent anaerobic conditions from occurring. Aeration of highly polluted rivers and stre-

ams has also been used to avoid anaerobic conditions. A wide spectrum of equipment is available to provide the aeration.

Pure oxygen has been used in Danish Lake Hald instead of air. The water quality of the lake was permanently improved after the oxygenation started. Lately, the method has also been applied for Lake Fure close to Copenhagen. Pure oxygen was pumped to the three deepest points of the lake. In some cases, however, the effect was not very great or as permanent as with other techniques, for instance siphoning of hypolimnetic water.

### CIRCULATION OF WATER

Induced water circulation can be used to break down a thermocline. This might prevent the formation of anaerobic zones and the release of phosphorus from sediments. Furthermore, circulation is able to transfer phytoplankton from the photic zone to deeper waters where light conditions are weaker and so photosynthesis is either considerably reduced or ceases, depending upon how long the cells are kept out of the photic zone.

## ■ 13. ESTUARINE & COASTAL AREAS: HOW TO PREVENT DEGRADATION AND RESTORE

### ECOHYDROLOGY AND PHYTOTECHNOLOGY AS MANAGEMENT TOOLS FOR ESTUARIES AND COASTAL AREAS

Basic to any management plan is the need for a complete knowledge about a system's functioning, how it is structured, what are the key species and determinant environmental factors, what were the pristine characteristics of the area (necessary to establish restoration objectives), what are the disturbance factors and what are their consequences to the system (necessary for mitigation purposes). Ecohydrology relates hydrological factors and ecological phenomena in a two-way perspective, which enables the control of ecology through hydrology and vice-versa. Phytotechnologies use the ability of plants to retain sediments and control nutrient fluxes to restore impacted areas. Ecohydrology and phytotechnology are environmentally friendly techniques and can provide adequate and sustainable solutions for a large number of problems and impacts in estuaries and coastal areas.

### MITIGATION AND REMEDIATION IN ESTUARIES AND COASTAL AREAS

Estuaries and coastal areas are well known for their high productivity, high carrying capacity and ability to support, apart from resident species, a variety of migratory fish, birds and invertebrates. The maximization of this capacity depends on a variety of interacting attributes, several of which reflect the significance of processes in the catchment and the need for a holistic approach for successful estuarine management. However, several actions or activities are responsible for reducing the capacity of estuaries and coastal areas to play their role as highly productive and biodiverse ecosystems. When these actions or activities cause modifications in habitat characteristics and hamper the normal use by resident or migratory species, including humans, remediation and mitigation techniques may be applied to restore the system to pre-disturbance conditions, or to as pristine as possible. Mitigation and restoration involve the same types of activities but are done for slightly different reasons. Mitigation is done to compensate damage done by a recent new disturbing factor and aims to replace the habitats and values

lost in a particular disturbed site. Restoration aims to compensate historical losses and to re-establish past values and provide an enhancement of estuarine and coastal values. Typically, mitigation and restoration actions involve creation, restoration or enhancement of estuarine and coastal areas. Creation refers to the addition of a new area, for example, construction of a salt marsh or tidal flat. Restoration refers to the return of parts of an estuary or coastal area that formerly belonged to those systems, such as can be achieved by removing or breaching a dike to allow return of tidal action. Enhancement refers to the improvement of the quality of an estuarine or coastal area and is frequently linked with the need to increase flushing and water circulation, which can be achieved by opening or enlarging channels for water circulation. However, the final goal of estuarine and coastal management is, by planning and monitoring the activities and uses of estuarine and coastal areas according to their physical, chemical and biological characteristics, to eliminate the need for mitigation or restoration.

### PREVENTION OF DEGRADATION AND RESTORATION OF ESTUARIES AND COASTAL AREAS

Degradation of estuarine and coastal areas can be caused by a large number of activities and actions, both natural and human, which should be avoided or prevented because of their potential for immediate or long-term damage to estuarine and coastal systems. These include such processes as sedimentation, nutrient loading and eutrophication, toxic algal blooms, pollution, degradation of habitats and introduction of exotic species.

### PREVENTION OF EUTROPHICATION USING PHYTOTECHNOLOGY

Prevention of eutrophication in estuaries and coastal areas includes control of nutrient loading in the entire catchment area. Intensive agricultural practices, tourism (e.g., golf) and manure resulting from cattle breeding provide excessive quantities of nutrients that reach an estuary by runoff or via groundwater and should be carefully monitored. Upstream riparian and downstream salt-marsh or mangrove vegetation play a role as buf-

fers, retaining nutrients and reducing loads entering estuarine waters from adjacent lands. Therefore, to prevent eutrophication, damage or destruction of riparian, saltmarsh or mangrove vegetation should be avoided. However, if prevention fails and restoration is necessary, ecologically sustainable solutions can be achieved using ecohydrology and phytotechnologies.

Controlling the eutrophication process and restoring an ecosystem to more pristine conditions can be done by acting in both top-down and bottom-up directions. Increasing the abundance of herbivores is a top-down control that uses natural filterers or grazers to control algal biomass and improve water quality in systems that have undergone eutrophication - an ecohydrological approach.

In fact, as was argued by Herman & Scholten (1990), top-down control of phytoplankton biomass by bivalve grazing makes a system more resilient to increases in external nutrient loading, and in this sense the bivalve population acts as a eutrophication control (Box 13.1).

Eutrophication control by using bivalve suspension feeders has been suggested as a means to combat algal blooms, both in marine and freshwater systems (Takeda & Kurihara, 1994). However, it should be realized that grazing will also enlarge the pool of inorganic nutrients. As was pointed out by Herman & Scholten (1990), this large pool of unused nutrients may be profitable to any primary producer that is less susceptible to grazing by the bivalves, for example, macro-algae like *Ulva* sp. or the colony-forming *Phaeocystis* sp.. Eutrophication control by bivalves involves the risk of a sudden shift in an ecosystem towards another, equally undesirable state, and should therefore be accompanied by nutrient input reduction.

Strategies to prevent nutrients reaching an estuary may include the canalization of nutrient-rich waters through inactive areas (e.g., old salt extraction areas, as suggested by Marques et al, in press) where buffering zones, using phytotechnologies, can be created. However, if a nutrient load enters estuarine waters, freshwater discharge pulses during ebb tide may help by diluting nutrient concentrations and flushing the estuary. Moreover, the use of floating systems („floating bioplato“) with

### BOX 13.1 Top down control of phytoplankton biomass by bivalve grazing

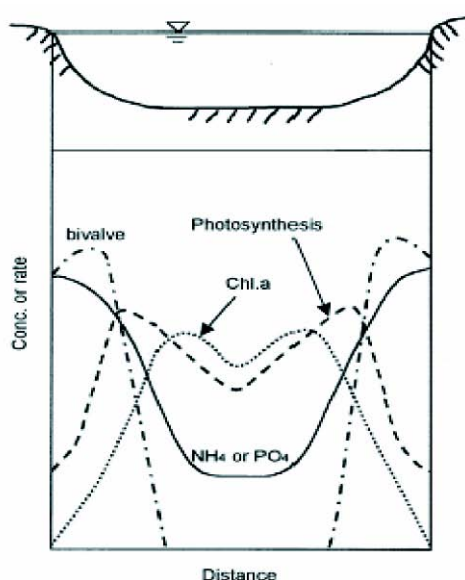

**Schematic biomass distributions of the bivalve *C. japonica*, concentrations of chlorophyll *a* and the nutrients, NH<sub>3</sub>-N and PO<sub>4</sub>-P, and the rate of primary production or photosynthesis in a vertical cross-section of Lake Shinji (a coastal saline lake).**

(modified from Nakamura & Kerciku, 2000)

macroalgae can be used to absorb nutrients directly from water bodies, where needed, even in coastal areas, as suggested by Hodgkin & Birch (1998). However, the periodical harvest of macrophytes and macroalgae is necessary to avoid the release of nutrients back to the water as a result of their decomposition after death.

### CONTROL OF TOXIC MICROALGAL BLOOMS USING ECOHYDROLOGY

Algal blooms generally only occur when nutrient levels are high. A microalgal bloom is defined as the visible appearance of free-floating algae or distinct discolouration of surface water and/or, an algal cell count greater than 2000 cells ml<sup>-1</sup> of water.

To prevent microalgal blooms the basic approach is to control nutrient loads and, indirectly, act on the factors responsible for their excessive production. However, not only nutrient concentrations, but also the ratio N:P:Si (1:1:16) should be monitored. In fact, particularly in dammed estuaries, changes in the ratio occur, since nutrients are trapped in a dam, reducing silica availability downstream, while phosphorus and nitrogen concentrations are re-established by anthropogenic discharges (e.g., sewage, etc.). This decrease of Si may be limiting to diatom growth, the first stage of phytoplanktonic succession (Rocha et al., 2002). A shift in the phytoplankton community may thus occur, favouring the growth of cyanobacteria that, due to the availability of nutrients not used by diatoms, may reach bloom concentrations. The fact that some cyanobacteria (e.g., *Microcystis*) and dinoflagellates (e.g., *Dinophysis*) may become toxic at high concentrations constitutes an added problem to water quality degradation in estuarine and coastal zones. Also, changes in estuarine and coastal water circulation (e.g., caused by construction of dykes, breakwaters, marinas) that may reduce circulation or tidal effects in some areas, promote nutrient accumulation. Therefore, prevention of microalgal blooms should include: control of factors responsible for nutrient production and loading into water bodies, control of water quantity retained by dams and control of activities causing changes in water circulation in estuaries and coastal waters.

Mitigation of microalgal bloom effects may include control of nutrient loads into estuaries and coastal waters by creating buffering zones with riparian, salt marsh and mangrove vegetation. Nutrient ratios can be maintained by management of dam discharge. Such controlled discharge can also contribute to stimulating zooplankton growth and promote the top-down control of microalgae. In fact, pulses of freshwater discharge (short-term inflows, 1-3 days) with their associated nutrient load, increases phytoplankton species diversity, as estimated in modelling studies (Roelke, 2000) and observed in microcosm experiments (Sommer, 1986) and field studies (Morais et al., 2003). This occurs because disturbances over ranges of frequ-

ency and magnitude suppress competitive exclusion and promote high species diversity (Hutchinson, 1961). Because phytoplankton are often able to respond more quickly to disturbance (physical-chemical conditions) than zooplankton (Sommer, 1986), succession from less edible, slower growing k-selected phytoplankton species to more edible and rapidly growing r-selected species, might occur. This will stimulate zooplankton growth resulting in a greater grazing pressure that will prevent the excessive accumulation of phytoplankton and reduce the risk of algal blooms developing (Roelke, 2000). Zooplanktonic grazing pressure can also be increased by controlling and reducing the abundance of zooplanktivorous fishes, as shown by Zalewski et al. (1990) in freshwater systems. Similar interactions were observed in the Guadiana Estuary (south Portugal), where top-down control of mesozooplankton and microzooplankton by fishes efficiently reduced grazing upon phytoplankton (Box 13.2). Also, an increase of bivalve species abundance, mainly filter-feeding species, may reduce microalgal abundance and control toxic blooms, as pointed out above. Finally, widening, opening or cleaning river and estuarine branches enables water circulation to dilute microalgal abundance and helps flush them to the open ocean, reducing the risk of toxic algal blooms.

#### **CONTROL OF ESTUARINE AND COASTAL EROSION USING PHYTOTECNOLOGIES**

Human activities in a river basin are often responsible for accelerated erosion of sediments that can be transported to a river during rainy periods or floods, contributing to sedimentation in estuaries and coastal areas. Decreased river discharge into an estuary, as in dammed rivers, promotes sediment transport from coastal areas into the estuary. Trapping of larger grain size sediments by dams reduces sediment grain size in estuarine and coastal areas, affects benthic habitats, reduces sediment stability for plants, affects salt marsh and sand dune stability, and causes an inward displacement of the coast line (Box 13.3).

In order to prevent such environmental consequences to estuarine and coastal ecosystems, activities that interfere with sediment transport should



**BOX 13.2**

The ecohydrology concept applied to the control of toxic algal blooms  
 Bottom-up and top-down control using freshwater discharge into  
 the Guadiana estuary (SE Portugal)

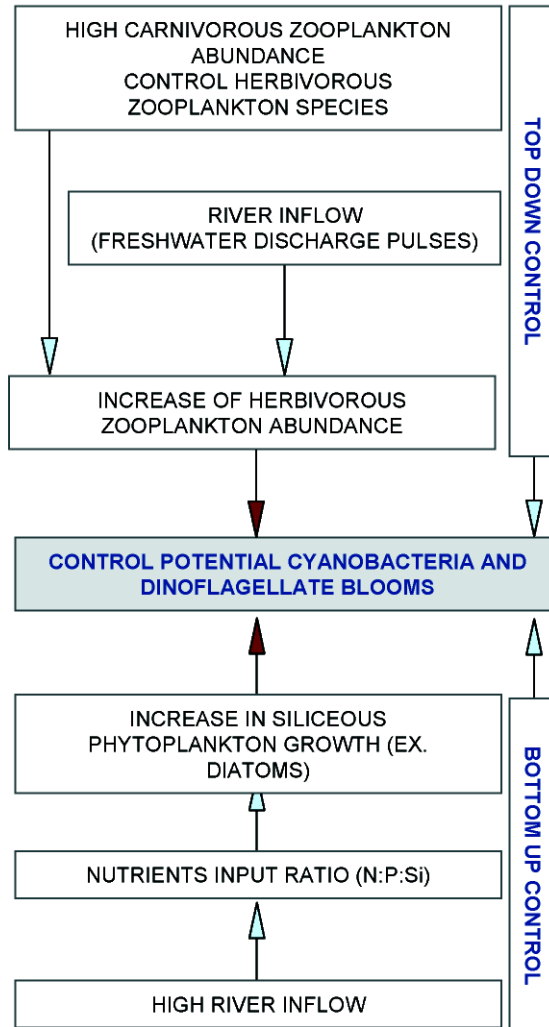
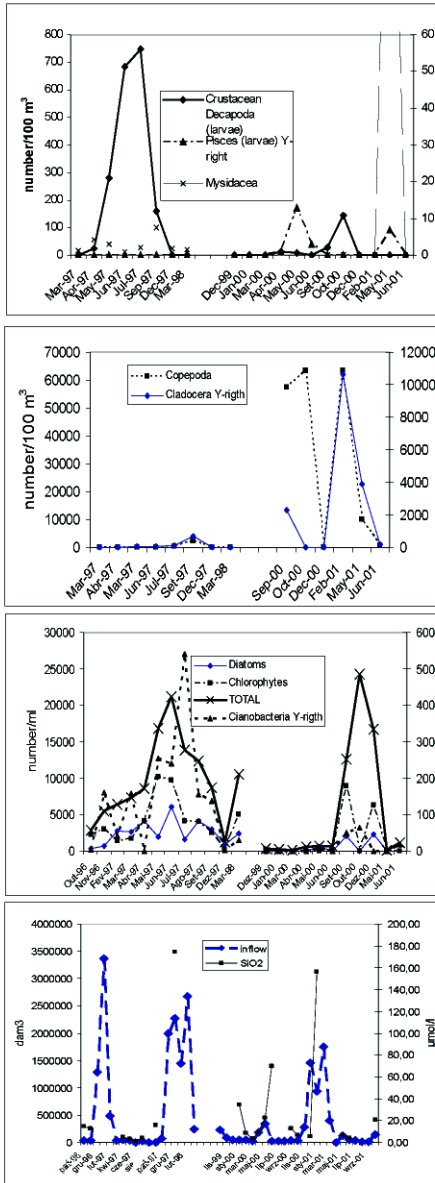

Bottom-up control is based on the fact that high river inflow increases Si concentration and promotes diatom growth, which is inversely related to cyanobacterial growth (B). Top-down control can be achieved also by controlling river inflow, as in dammed rivers. During reduced inflow periods mesozooplanktonic species control the abundance of microzooplankton (C and D), thus limiting this group's grazing effect upon phytoplankton and allowing their abundance to rise (B).

be avoided or carefully monitored, and agricultural practices that reduce erosion should be encouraged. Any form of artificial mouth management should form part of a comprehensive, holistic management plan for an estuary and catchment and should also integrate a water release management plan for dams.

Restoration of areas where erosion occurs can be achieved by restoring physical structures in estuaries, like water flow patterns and vegetation. In this context, phytotechnologies can play a fundamental role. Restoration of riparian vegetation in the upper estuary, salt-marsh vegetation in the lower estuary and dune vegetation on the coast line (Box 13.3A), are environmentally safe and sustainable actions that contribute to retaining sediments in their area of origin, preventing both erosion and loading of massive amounts of sediment into a system.

### DUNES STABILISATION

In order to restore dunes sand can be mechanically added to places where it is needed. This technique has the advantage of allowing „sculpturing“ of a dune to create the best conditions for vegetation development which grows more easily on natural slopes than on very steep slopes (Wilcock, 1977). Attention must be drawn to the need for promoting well established vegetation that can support erosion caused by tides, storms and wind. Sand can be trapped and maintained on dunes by using sand fences. These structures reduce wind velocity and cause deposition of sand grains. Their effectiveness, however, is limited since sand fences can be buried after a short period of time - depending on the winds - and become ineffective. The advantage of sand fences is that they can be installed during any season and they are fully effective immediately after installation (Woodhouse, 1978).

**BOX 13.3 [A]**  
Factors impacting estuaries and coastal areas

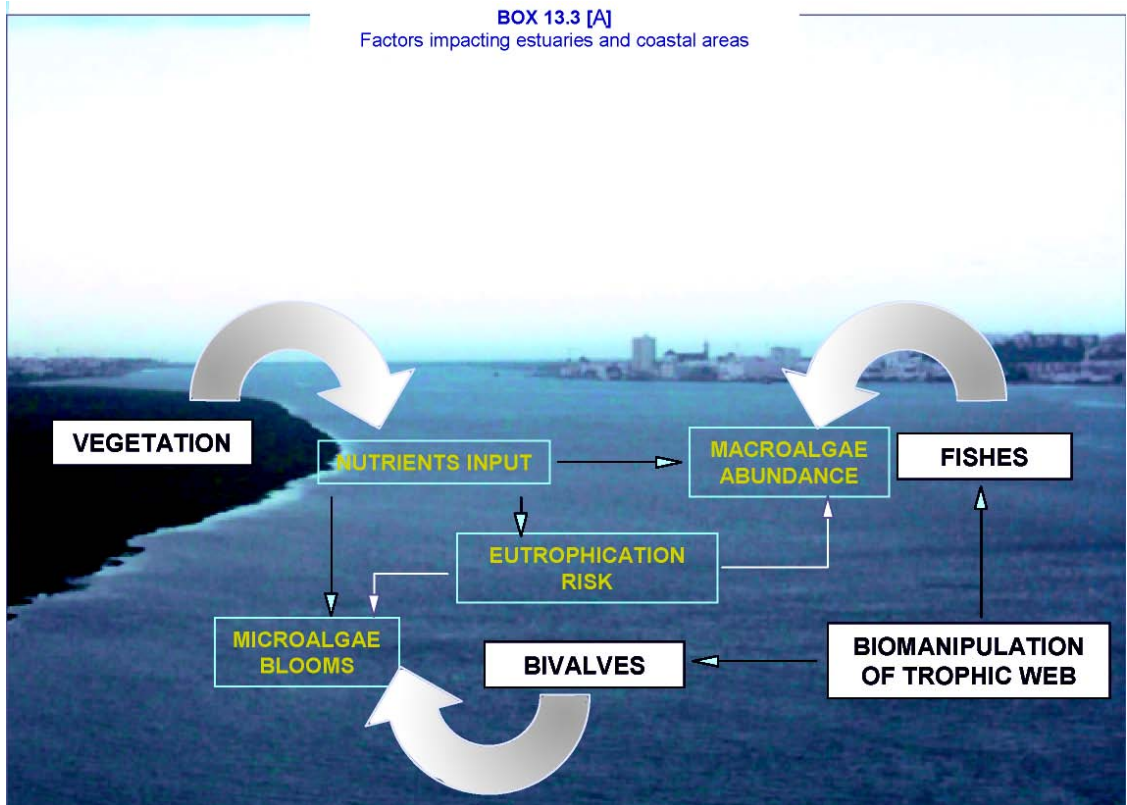

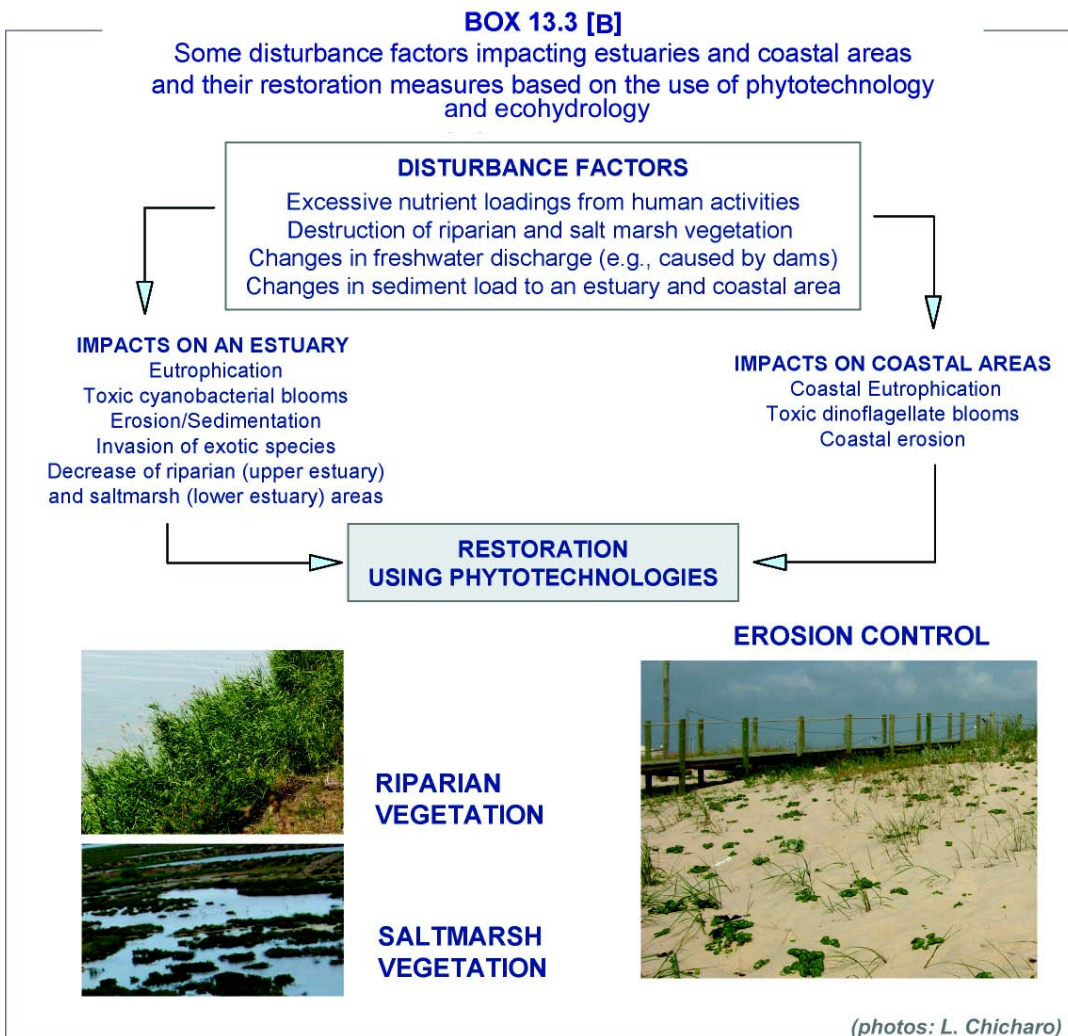

The best way to stabilize dunes is using vegetation since it is usually the less expensive, most aesthetically pleasing, and only self-repairing technique available (Woodhouse, 1978). Dune vegetation acts by trapping sand transported by wind, consolidating a dune and reducing dune migration. Mats and netting are useful in protecting dunes while transplanted dune grasses are being established (Dahl, 1975), mainly because they protect new seedlings (Box 13.4).

**CONCLUSIONS**

Application of ecohydrological and phytotechnological solutions to management actions to be taken in estuarine and coastal areas is not as straightforward as in closed systems like reservoirs, lakes or even in rivers, because of their high hydro-

drological dynamics, where tides associated with other factors play a determinant and variable role. However, tidal currents and controlled dam discharges can be key factors in regulating freshwater inflow, residence time and dilution rates - structuring factors to life in these ecosystems - and, therefore, provide an excellent tool to manage estuaries and coastal areas based on ecohydrological and phytotechnological concepts.

**BOX 13.4**

**Phytotechnology solutions for coastal dunes stabilisation**

**Mitigation of human impact on development of dune vegetation**



**Sand fences retaining sand**

**Re-vegetation and wind transported sand trapping**



**A sand fence system filled with sand and highly ineffective**



**Use of netting for supporting vegetation grow**



**An example of well vegetated and consolidated dune**



*photos: A-D, F: L. Chicharo, E: I. Wagner-Lotkowska*

## ■ 14.A. SOCIO-ECONOMIC ASPECTS OF ECOHYDROLOGY & PHYTO TECHNOLOGY APPLICATIONS IN INTEGRATED WATERSHED MANAGEMENT IWM

The maintenance of homeostatic equilibrium in an ecosystem in order to ensure its ability to continue to produce the desired resources, and to preserve and even enhance its resilience and carrying capacity to assimilate natural and anthropogenic stresses, is a key element in achieving sustainable development. The ecohydrological approach, by integrating knowledge of biota with that of a wide range of hydrological processes at medium or mesoscales (which includes microhabitats, river systems, and catchment areas), provides the scientific background for maintaining the integrity of ecological processes. This integration is one of the three key considerations on which the concept of sustainable development has been built, as depicted in Box 14.1.

Being that water is essential to human life and economic growth, sound management of water resources is central to sustainable development. Ecohydrology, therefore, recognises that sustainable development is dependent on the ability of an ecosystem to maintain evolutionary-established processes and patterns of water and nutrient circulations and energy flows at a basin scale.

In promoting the integration of a catchment and its biota into a single entity, the use of ecosystem properties becomes a management tool within which ecohydrology can address fundamental aspects of water resources management. In effect, it provides the sound scientific basis for adopting a watershed as the basic planning unit. By incorporating the concept of improved ecosystem resilience as a management tool, ecohydrology strengthens the rationale for adopting a preventive, holistic, and global approach to the watershed - as opposed to the reactive, sectoral, and site specific approach typical of present extended practices in water resources management. At the same time, ecohydrology stresses the importance of ecotechnological measures as an integral component of water management, complementing standard engineering approaches.

But water resources management goes beyond these fundamental aspects understanding natural processes and the adoption of technological approaches to address the optimum development and

use of water resources and their protection. Further, development, use, and protection, in terms of an ecohydrological approach, extend to present and intergenerational equity concerns and a full accounting for the economic, social, and environmental values of water. Thus, ecohydrology involves policy, institutional, economic, social, environmental and legal issues, configuring a multidimensional space that needs to be integrated by means of sound management tools and approaches. During recent decades, knowledge derived from successes and failures in the management of the environment and natural resources, particularly water, has contributed to the build up of a well documented set of basic principles for sound management of water and other natural resources, and for the protection of the environment, particularly aquatic ecosystems. These principles constitute a rationale founded upon scientific knowledge, which, according to generalized worldwide experience, guarantee a better approach to the global objective of „sustainable management of water resources, including the protection of aquatic ecosystems and freshwater living resources“. Mar del Plata 1977, Dublin 1992, Río de Janeiro 1992, and many other renowned international meetings are milestones at which some basic global understandings, such as the rational use of water; integrated management of water resources; use of the watershed as a basic planning unit; the social and economic value of water; the role of water in ecosystem protection; etc., have been achieved. Together with the need for sound management tools, such as proper regulatory frameworks, the incorporation and transfer of „clean“ technologies, environmental education, public participation, access to information, use of economic and financial instruments, and the promotion of sustainable practices, etc., these principles have gained international consensus. In particular, Dublin's principle 1 stands out among them because of its extended and complete recognition. The international community, in its search for universal truths and simplicity, attempted to summarize this global knowledge in „paradigms“, which express in a few words, a complex set of

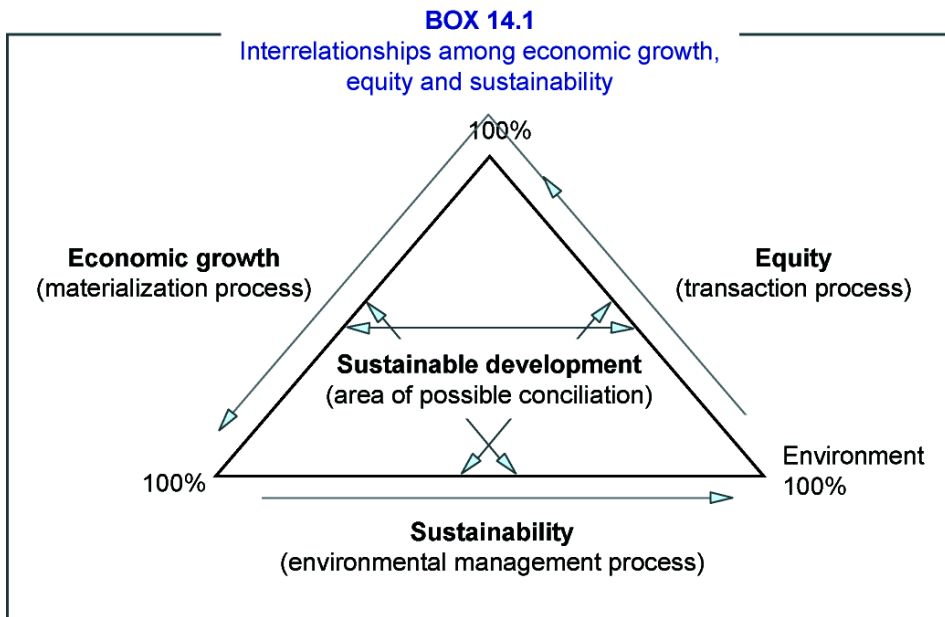

scientific, technological, policy, institutional, social, economic, and environmental issues. At the United Nations Conference on Environment and Development (UNCED 92), „sustainable development” - based on the definition proposed by the renowned Brundtland Commission 2 - was incorporated into a broadly-accepted paradigm expressing the need to carry out developmental actions within the framework of economic efficiency, social acceptability, and ecological integrity.

With regard to water resources, Chapter 18 of UNCED’s Agenda 21 noted the concept of integrated water resources management was based on „the perception of water as an integral part of the ecosystem, a natural resource and a social and economic good, whose quantity and quality determine the nature of its utilization”. Including the Dublin principles, integrated water resources management is presently being widely adopted as the paradigm which should drive society toward sustainable development of water resources. The Global Water Partnership (GWP), which is intensively contributing to the spread the of concept, adopted the following definition: „Integrated water resources management is a process that promotes the coordinated development and management of water, land and related resources in order to maximize the resultant economic and social welfare in an equitable manner without com-

promising the sustainability of vital ecosystems.” The term „integrated” implies a multidimensional concept that calls for the simultaneous consideration of natural resources, social, cultural, institutional, regulatory, economic, and political issues in a watershed. As a reaction to the sectoral, thematic and geographical fragmentation that has characterized present water resources management in most parts of the world, integrated water resources management pursues integration within and between the natural and socio-economic components of the environment, utilizing the river basin as the natural planning unit.

The concept of Integrated Water Resources Management - in contrast to „traditional,” fragmented water resources management - at its most fundamental level is as concerned with the management of water demand as with its supply. Thus, integration can be considered within two basic systems:

- ▶ the natural system, with its critical importance for resource availability and quality, and
- ▶ the human system, which fundamentally determines the levels of resource use, waste production, and pollution of the resource, and which must also set development priorities.

Integration has to occur both within and between these categories, taking into account variability in time and space.

Ecohydrology is another „paradigm“ which addresses the integrated study and use of ecosystems, including their hydrological characteristics and processes, and their combined potential to influence water dynamics and quality, particularly at the catchment scale. In terms of integrated water resources management, it addresses, and scientifically strongly supports, integration within the natural system as well as providing guiding principles and tools to integrate a consideration of ecosystem components within the development framework. Furthermore, it enhances a preventive approach, through improvement of ecosystem resilience that amplifies opportunities for achieving sustainable development.

Within the context of integrated water resources management, ecohydrology should be incorporated into the objectives and policy framework for water management at the highest institutional levels, as well as be disseminated at the community level to promote environmental awareness, enhance water resource values, and stimulate their protection.

Ecohydrology also provides scientific support for the use of a watershed as the planning unit of choice for water resources management. In this manner, ecohydrology contributes to building a basin approach to water resources management at the community level. In effect, ecohydrology creates a common watershed vision that is fundamental for promoting the active involvement and participation of stakeholders, and for putting into effect a process of „social negotiation“ that should be at the root of all decision-making within a basin. Also, it facilitates the solution of downstream-upstream conflicts through enhancing so-called „hydro-solidarity“.

Ecohydrology also helps to strengthen the incorporation of social and environmental values into strategic water resources planning at the water-

shed level, facilitating technological approaches that will contribute to sustainability and, making use of ecosystem properties. Improved ecosystem resilience and ecotechnologies should be an integral part of pollution prevention and water quality restoration programs and measures.

By simultaneously addressing both hydrological and biotic processes at various levels (microhabitat, river systems, entire watersheds) within an ecosystem, ecohydrology provides a sound basis for land and water use, as well as for integrated surface and groundwater management. Thus, ecohydrological principles may strongly influence the conceptual basis upon which regulatory and economic instruments are devised to induce human behaviours compatible with the objectives and goals of strategic, basin-scale planning (TAC Background Papers No. 4. Global Water Partnership. Technical Advisory Committee, 2000).

Because of its holistic and basin-wide approaches, ecohydrology requires a strong commitment from governments and water users to strengthen the knowledge base, in terms of monitoring, data management, research and technological development. It also involves the joint efforts of governmental agencies and stakeholders across various jurisdictional boundaries within a basin to coordinate data gathering, information exchange, and joint interpretation of ecosystem functioning, root cause analyses, and the effects of human interventions on ecosystem components. It basically requires that stakeholders, users, and civil society become aware of its principles and guidelines for action, thus promoting a bottom-up process that will instil ecohydrological principles into institutional and legal frameworks.

Therefore, ecohydrology should evolve from a scientific approach to an institutional approach, within the framework of integrated water resources management, incorporating the economic, financial and social dimensions that currently characterize globally-accepted paradigms.

#### **MAKE SURE TO CHECK THESE RESOURCES:**

Guidelines: chapters 1.D, 1.F, 10

## ■ 14.B. CAN GLOBAL CLIMATE CHANGES AFFECT MANAGEMENT OUTCOMES?

An assessment of potential water resources impacts associated with climate change, and the evaluation of possible water management strategies, deserves increased attention of the world's community. Although „No global crisis is likely to shake the world the way the energy crisis of the seventies did“ [Postel 1992], the global and regional food supply and economic development may be affected by climate-induced changes in water availability in crop-producing regions and in large urban agglomerations. The assessment of climate change impacts on water resources management attempts to portray how the range of possible changes in temperature, precipitation and runoff is likely to affect the range of water uses and their socio-economic implications.

It is still difficult to predict or quantitatively assess the impacts of climate perturbations on water management. There is, moreover, no general consensus among most of national water institutions on the possible adverse consequences of change in climatic processes caused by anthropogenic forcing. In spite of existing uncertainties, the impact of climate on water systems may create serious social problems, at least in vulnerable regions of the world. In the long-term thinking about the Earth's economic future, this issue should not be neglected. Scenarios of possible trends in demographic, economic, technological, and geophysical processes must be investigated. The complexity of the global atmospheric/hydrologic system means that one cannot rule out abrupt changes, and the world's water community should be prepared to cope with them.

The progress in assessing the implications of climate change on water supply and demand, and consequently on management of catchment systems, as well as in assessing the impact of climate on physical, chemical and biological processes, is evident. However, most of the relevant theories and models still need to be improved in order to meet requirements of water resources practice. The IPCC reports (1996, 2001) outlined difficulties in analyzing climate change impacts on water management. Although a number of case studies have been conducted in specific river basins - almost exclusively in developed countries - the un-

certainties in climate change impact on water management remain large. Climate model will tend to estimate that the world as a whole become more „moist“, nevertheless some large areas may experience a decrease in precipitation, accompanied by increased evapotranspiration due to higher temperatures. It is necessary to distinguish between the physical effects of climate change and the impacts reflecting societal values placed on a change in hydrological quantities. This impact highly depends on the level of development of the water system: in some cases large climate change-induced hydrological effects may lead to insignificant increases of economic costs, while in water scarce regions a small change may have dramatic consequences. A conjunctive use system involving several reservoirs, river regulation and groundwater withdrawals will be affected differently than a simple supply system based on direct water abstractions from a non-regulated river.

Studies that have considered possible changes in regional water management for a variety of climate scenarios fall into three categories. The first infers changes in potential water supply due to changes in the water balance of a catchment. Problems in maintaining irrigation supplies from direct river abstractions may be inferred, for example, if summer river flows are simulated to decline. The second research group considered the sensitivity of managed supply/demand systems - usually containing storage reservoirs - to changes in hydrologic inputs. The third group of studies examined integrated water demand/supply systems, additionally taking into account climate impacts on physical and biological processes in rivers and lakes.

Demands may increase in all water-use sectors with an increase of temperature - the broadly accepted consequence of global climate change. Unfortunately, regional and local precipitation changes, having also important influences on water demands, are much less clear. Studies on domestic and industrial water consumption show a great deal of opportunity to adapt to changed climate. Many of the responses being proposed to adapt to climate change require reduction of demands and reallocation of water among water users. The big-



gest current pressure on water resources is caused by high population increases in some parts of the world, and by progressing concentration of economic activities in big urban agglomerations. Results of investigations on domestic water use reported in the literature lead to the conclusion that per capita water requirements will probably change insignificantly in a warmer climate. The amount of water needed for technological processes in industry is rather insensitive to changes in temperature and precipitation, with the exception of increased demand of water for cooling purposes. Hydropower production will decrease with lower river flow.

Serious problems may arise in agriculture, which is the largest consumer of water in the world, accounting at present for 2/3 of global water withdrawals. As human populations in developing countries increase during the next century, the amount of irrigated croplands may have to increase to guarantee global food security. Some recent studies indicate that for a 1°C increase of air temperature one may expect a 12 to 25 percent increase in irrigation demands. Another study shows that for a broad range of prescribed temperature increases, irrigation demand may increase even in cases of up to a 20% precipitation increase. Consequently, on a global scale the amount of water needed for sustainable agricultural production may double by the middle of the next century. This, in turn, may largely extend the number of countries suffering chronic water scarcity. It is important to emphasize that the ultimate effect of global warming on water demand for irrigation depends significantly on agricultural policy, food prices and more equitable distribution of food among nations. At least for the next two decades, non-climatic factors will probably dictate what kind of measures should be undertaken to secure sustainable water supplies. Climate change predictions will, however, add a new highly uncertain component to the challenge of managing water resources. There are still large uncertainties that are propagated through the numerous levels of analysis as one moves from greenhouse gases scenarios; through the comparison of different global climate models outputs; transference of climatic data to

runoff and to other hydrologic variables; impacts on water management decisions; and, finally, on the socio-economic and incremental impacts of response measures. In addition, incremental impacts due exclusively to climate change should be differentiated from changes (sometimes also highly uncertain) that would occur in the absence of climate change.

Water management at present is frequently concerned with reconciling competing demands for limited water resources. At present, these conflicts are solved through legislation, prices, customs or a system of priority water rights. A change in both the amount of water available and water demanded is likely to lead to increased competition for resources. Conflicts may arise between users, regions, and countries, and their possible resolution depends highly on political and institutional arrangements in force. Because different users have different priorities and risk tolerances, the balance point among them, in the face of feasible climate change scenarios, may be quite different from now on (e.g., hydropower production and in-stream uses may be lost compared to domestic and agriculture water supply). The marginal costs of reducing additional increments of water scarcity risk rises rapidly in the case of supply with required high reliability.

Relatively few research results have assessed climate change effects on intensity and frequency of extreme hydrological events: floods and droughts. Unfortunately, the state-of-the-art global atmospheric models may have produced until recently, scenarios at too coarse spatial and temporal resolutions to be useful for assessing expected changes in hydrological extremes. However, recently observed increased variability of some climatic variables seems to have affected flood and drought risks in many regions of the world. The number of major flood disasters world-wide has grown in the past decades: six in the 1950s, seven in the 1960s, eight in the 1970s, 18 in the 1980s, and 26 in the 1990s (Berz 2001). In the second half of the 20th century there has been an increased number of droughts in some areas. An observed upward trend in the number of deaths and in material losses due to weather related disasters

might be at least partly explained by the non-stationary nature of climatic processes.

The fundamental question is what kind of adaptive measures may be applied to cope with possible negative consequences of climatic perturbations? The answer is not simple because of high uncertainties accompanying the climate change issue. The IPCC reports contain an extended discussion on the philosophy of adaptation, and a list of adaptation options suited to the range of water management problems that are expected under climate change. Based on a review of the most recent literature, it may be stated that few additional water management strategies, unique to climate change effects, have been proposed, other than to note that nations have to implement action plans for sustainable water resources management as part of their obligation towards AGENDA 21. The principles laid out in that document may serve as a guide for developing a policy that would enable river basin authorities and water stakeholders to prepare for the uncertain hydrologic and demand conditions that might accompany global warming.

There are many possibilities for adaptation measures or actions. An overview of water supply and demand management options is presented in IPCC documents. A long-term strategy requires that a series of plausible climate and development scenarios be formulated, based on different combinations of population and climate change prediction, along with economic, social and environmental objectives. After development strategies are established, taking into account the possibility of climate change, a set of alternative long-term water management policies might be formulated that consist of technical measures, policy instruments and institutional arrangements, designed to meet the objectives of a particular development setting.

The range of response strategies must then be compared and appraised, each with different levels of reliability, costs, environmental and socioeconomic impacts. Some of the water management strategies will be particularly well suited to deal with climate change uncertainty - i.e., to develop reliable, robust and resilient water sys-

tems focusing on environmental and economic sustainability. The performance of water systems should be tested under varying climatic conditions. After application of engineering design criteria to various climate alternatives, the selection of an optimal water resources plan must be based on social preferences and political realities. It should be added that engineering design procedures also evolve over time, and may be updated as meteorological and hydrological records are extended.

The nature of contemporary water resources management is such that countless factors, economic criteria, and design standards are incorporated because of the complexity of integrated water management and objectives (reliability, costs and safety). The key problem in responding to possible consequences of man-induced global warming is to decide when and what kind of adaptive measures should be undertaken to assure reliability of water supply and to protect against negative economic effects of hydrologic extremes. Water policy decisions always depend on local hydrologic conditions, economic situations, and national priorities. There is, for example, no reason to apply sophisticated decision-making techniques for river systems abundant of water when the results of any climate impact assessment will be trivial. On the other hand, even limited climatic disturbances may lead to a worsening water situation in arid and semi-arid regions, requiring urgent adaptation decisions.

There is no standard, prescribed approach. In watersheds that have little or no control of natural flows, and are largely dependent on precipitation, a different set of water management adaptation strategies should be implemented than in river basins with a high degree of control by storage reservoirs, canals, levees etc. Rapidly urbanizing areas will require different responses than agricultural regions. In general, if a rational water management strategy is undertaken to deal with reasonably foreseeable needs of a region in the absence of climate change, such a strategy may also serve to offset much of the range of possible adverse consequences of climate change.

Two approaches are advocated in dealing with

adaptation of water systems to changed climatic conditions (Waggoner 1990). Firstly, a „wait and see“ or „business as usual“ strategy, which means to postpone decisions on adaptation measures until more reliable information on global atmospheric processes become available. Existing water schemes remain unchanged then, and the new ones will be planned and implemented according to standard procedures. In the case of large hydraulic schemes a very long time is needed for their planning and implementation. As a result, this approach may cause undesirable delays in taking

necessary decisions. Secondly, a „minimum regret“ approach, when policy decisions are taken to solve current problems in the best possible way and, at the same time, to prepare water systems for possible changes and surprises by making them more robust, resilient and flexible for any future. The latter approach assumes that optimality rules should be applied to a range of climatic scenarios. Final decisions may be taken by comparing costs, benefits and losses for each scenario, and on a somewhat subjective interpretation of expected results.

**MAKE SURE TO CHECK THESE RESOURCES:**

Guidelines: chapters 4.H



## APPENDIX

## APPENDIX

**Appendix 1. General considerations of available methods for testing physical-chemical parameters of sediments, recommended holding time and storage conditions of samples**

		<b>HOLDING TIME AND STORAGE CONDITIONS</b>
<b>pH in pore water</b>	measured using an electronic pH metre with glass electrode	-
<b>Ammonia content in pore water</b>	- titrimetric method - ammonia selective electrode method - phenate method	
<b>Total Phosphorus (TP)</b>	After chemical or microwave mineralization - Spectrophotometric method	2 weeks; refrigerate, freeze
<b>Total Organic Carbon (TOC)</b>	- wet oxidation titration - modified titration - combustion after removal of carbonate by addition of HCl and subsequent drying – gas chromatography	
<b>Particle size distribution</b>	Provides information on percent content of sand, silt and clay. - wet sieving - hydrometric method - settling techniques - X-ray absorption	
<b>Percent water content</b>	Measured as a difference of wet weight of a sediment and dry weight after 6 h oven-drying at 105°C	
<b>Conductivity of pore water</b>	Electronic conductivity metre	
<b>Metals</b>	- Spectrophotometric (silver diethyldithiocarbonate) - Atomic Absorption Spectrophotometry - Atomic Emission Spectrophotometry - X-ray fluorescence - Neutron activation	
<b>Pesticides</b>	After extraction - Gas chromatography/mass spectrophotometry (GC/MS) - Gas chromatography/electron capture detection (GC/ECD)	7 days (until extraction), 30 days (after extraction); refrigerate, freeze
<b>Total sulphides</b>	Common in anoxic sediment, toxic for aquatic organisms - Potentiometric methods ASTM - APHA	28 days; refrigerate or NaOH; pH>9
<b>Sediment oxygen demand</b>	Provides information on dissolved oxygen uptake by sediments in terms of physical and biological processes. - including in-situ - respirometry and laboratory respirometry methods.	
<b>Sediment Biochemical Oxygen Demand</b>	Provides information on the dissolved oxygen consumed by microbial organisms while assimilating and oxidizing a organic matter - respirometry and laboratory respirometry methods in specific conditions	
<b>Sediment Chemical Oxygen Demand</b>	Chemical oxygen demand (COD) is a measure of the oxygen equivalent of organic matter content in a sample that is susceptible to oxidation by a strong chemical oxidant at elevated temperature and reduced pH. - Closed reflux/colourimetric method with dichromate (Cr <sub>2</sub> O <sub>7</sub> ) ions.	
<b>Cation Exchange Capacity of sediments</b>	Provides information relevant to metal bioavailability studies - treating samples with ammonium acetate, digesting with sodium hydroxide and titrating to determine the ammonium ion concentration.	
<b>Redox Potential (Eh) in sediments</b>	Provides information on the oxidation-reduction potential (ORP) of sediments. - Potentiometric measurements of Eh using a millivolt reader with a platinum electrode.	
<b>Alkalinity of Pore Water (freshwater sediments)</b>	Provides information on acid-neutralizing (i.e., proton-accepting) capacity of water. - Titration method with H <sub>2</sub> SO <sub>4</sub>	
<b>Loss of Ignition (organic content)</b>	Provides information on organic content. - Igniting the sediments at 550 ± 10° C	

**Appendix 2. Example of field data sheet for soil assessment**

<b>DRILLING CONTRACTOR</b>					<b>ENGINEERING-SCIENCE DRILLING RECORD</b>		
Driller: _____					PROJECT NAME _____		
Inspector: _____					BORING NO. _____		
Rig Type: _____					PROJECT NO. _____		
Drilling Method _____					Location _____		
<b>GROUNDWATER OBSERVATIONS</b>					<b>PLOT PLAN</b>		
WL TOC					Weather _____		
Time					Date/Time Start _____		
Date					Date/Time Finish _____		
Photovac Reading	Sample I.D.	Sample Depths	% Recovery	SPT	FIELD IDENTIFICATION OF MATERIAL	WELL SCHEMATIC	COMMENTS
		1					
		2					
		3					
<b>STANDARD PENETRATION TEST</b>							
SUMMARY.....							
<i>SS=SPLIT SPOON A=AUGERCUTTINGS C=CORED</i>							

**Appendix 3. An example of selected parameters from Sediment Chemical Criteria by EPA, Washington, USA. ([http://www.ecy.wa.gov/programs/tcp/smu/sed\\_chem.htm](http://www.ecy.wa.gov/programs/tcp/smu/sed_chem.htm))**

The "no effects" level - the Sediment Quality Standards, WAC 172-204-320 -- used as a sediment quality goal. The "minor adverse effects" level -- The Sediment Impact Zone Maximum Level, WAC 173-204-420; and the Sediment Cleanup Screening Level/Minimum Cleanup Level, WAC 173-204-520 -- used as an upper regulatory level for source control and cleanup decision making.

	mg kg <sup>-1</sup> dry weight (parts per million (ppm) dry)	<b>SEDIMENT IMPACT ZONE MAXIMUM LEVEL, SEDIMENT CLEANUP SCREENING, LEVEL/MINIMUM CLEANUP LEVEL</b> mg kg <sup>-1</sup> dry weight (parts per million (ppm) dry)
<b>arsenic</b>	57	93
<b>cadmium</b>	5,1	6,7
<b>chromium</b>	260	270
<b>copper</b>	390	390
<b>lead</b>	450	530
<b>mercury</b>	0,41	0,59
<b>silver</b>	6,1	6,1
<b>zinc</b>	410	960
	mg kg <sup>-1</sup> Organic Carbon (ppm Carbon)	mg kg <sup>-1</sup> Organic Carbon (ppm Carbon)
<b>naphthalene</b>	99	170
<b>benzo(a)pyrene</b>	99	210
<b>total pcbs</b>	12	65
	µg kg <sup>-1</sup> dry weight (parts per billion (ppb) dry)	µg kg <sup>-1</sup> dry weight (parts per billion (ppb) dry)
<b>phenol</b>	420	1200

**Appendix 4. Example of a field form and required analysis for sediment sampling**

NAME OF RIVER/LAKE	DATE	TIME	SITE NUMBER

STATION COORDINATES (GPS)	
Latitude:	N .
Longitude:	W .

DESCRIPTION OF STATION LOCATION	TYPE OF SAMPLER	
	grab	
	core	

SEDIMENT DESCRIPTION	
Colour	
Texture	
Odour/sheen:	
Benthic organisms:	

**Appendix 5. Example of data sheet for physical, chemical and biological examination of lakes and reservoirs**

NAME OF RIVER/LAKE	DATE	TIME	SITE NUMBER

STATION COORDINATES (GPS)	
Latitude:	N .
Longitude:	W .

METEOROLOGICAL CONDITIONS			
Wind velocity		Air temperature	
Wind direction		Precipitation	
Cloudiness			

PHYSICAL PARAMETERS			CHEMICAL PARAMETERS	
depth	O <sub>2</sub> concentration	Water temperature		concentration
0 m			NO <sub>2</sub> -N	
1 m			NO <sub>3</sub> -N	
2 m			NH <sub>4</sub> -N	
..... m			TN	
Secchi disc visibility			PO <sub>3</sub> -P	
pH			TP	
Conductivity			SiO <sub>2</sub>	
			DOC	

BIOLOGICAL PARAMETERS			
Chlorophyll a concentration			
<i>In vivo</i> fluorescence of chlorophyll			
Bacterioplankton biomass			
Phytoplankton biomass			
Zooplankton biomass			
Pelagic fish biomass			

GENERAL OBSERVATIONS



## Appendix 6. Biotests used for analysis of cyanobacterial toxicity

TESTED ORGANISM	ASSAY	FORM OF ORGANISM	REFERENCES
<b>Mice</b>	Cell damage Lethality test	Cultured organisms	Falconer et al., 1981; Jackson et al., 1984; Yoshida et al., 1997, Tarczyska et al., 2000
<b>Flies</b> <i>Drosophila melanogaster</i>	Lethality test	Cultured organisms	Swoboda et al., 1994
<b>Mosquitoes</b>	Lethality test	Cultured organisms	Kiviranta, 1992; Kiviranta & Abdel-Hameed, 1994
<b>Plant</b> <i>Spirodela oligorrhiza</i>	Growth inhibition	Culture	Tarczyska et al., 1997; Romanowska-Duda & Tarczyska, 2002
<b>Plant</b> <i>Lemna minor L.</i>	Growth inhibition	Culture	Weiß et al., 2000
<b>Microtox®</b> <i>Vibrio fischeri</i>	Bioluminescence inhibition	Freeze-dried bacteria	Marsalek & Blaha, 2000
<b>ToxAlert®</b> <i>Vibrio fischeri</i>	Bioluminescence inhibition	Liquid bacteria Freeze-dried bacteria	Mankiewicz et al., 2003
<b>ToxiChromoPad™</b> <i>Escherichia coli</i>	Enzymatic activity	Liquid bacteria	Marsalek & Blaha, 2000
<b>Protoxkit FTM</b> <i>Tetraphymena thermophila</i>	Growth inhibition	Cysts (dormant eggs)	Tarczyska et al., 2000
<b>Protoxkit FTM</b> <i>Tetraphymena pyriformis</i>	Growth inhibition	Cysts (dormant eggs)	Marsalek & Blaha, 2000; Nalecz-Jawecki et al., 2002
<b>Daphtoxkit FTM magna</b> <i>Daphnia magna</i>	Lethality test	Ehippia (dormant eggs)	Tarczyska et al., 2000, 2001; Nalecz-Jawecki et al., 2002
<b>Daphtoxkit FTM pulex</b> <i>Daphnia pulex:</i>	Lethality test	Ehippia (dormant eggs)	Kyselkova & Marsalek 2000
<b>Rotoxkit FTM</b> <i>Brachionus calicyflorus</i>	Lethality test	Cysts (dormant eggs)	Marsalek & Blaha, 2000; Nalecz-Jawecki et al. 2002
<b>Thamnotoxkit TTM</b> <i>Thamnocephalus platyurus</i>	Lethality test	Cysts (dormant eggs)	Tarczyska et al. 2000, 2001, Törökné 1999 and 2000, Marsalek and Blaha 2000, Nalecz-Jawecki et al. 2002
<b>Artoxkit M</b> <i>Artemia salina</i>	Lethality test	Cysts (dormant eggs)	Kyselkova & Marsalek 2000; Marsalek & Blaha, 2000; Nalecz-Jawecki et al., 2002;
<b>Spirotox</b> <i>Spirostomum ambiguum</i>	Cell deformation	Cryptological form	Tarczyska et al., 2000, 2001; Nalecz-Jawecki et al., 2002
<b>Nematode toxicity test</b> <i>Panagrellus redivivus</i>	Lethality test	Organisms in culture	Marsalek & Blaha, 2000

## Appendix 7. Enzymatic methods used for analysis of cyanobacterial toxicity

ENZYME	ASSAY	TYPE OF ASSAY	REFERENCES
Protein Phosphatase 1 (PP1)	PPIA (Protein Phosphatase Inhibition Assay)	Colourimetric	An & Carmichael 1994; Ward et al., 1997; Rapala et al., 2002
Protein Phosphatase 1 (PP1) Protein Phosphatase 2 (PP2)	PPIA (Protein Phosphatase Inhibition Assay)	Radiolabelled	Lambert et al., 1994; Fladmark et al., 1998; Flury et al., 2002;
Microcystin conjugate-enzyme	ELISA (Enzyme-Linked ImmunoSorbent Assay)	Colourimetric	Chorus & Bartram 1999; Flury et al. 2002

## Appendix 8. Summary of chromatographic methods for determining hepatotoxins (Nicholson &amp; Burch 2001).

	HPLC			CE	MMPB method
	UV detection	PDA detection	MS detection		
<b>Principle of the technique</b>	Toxins separated by HPLC. UV detection at 240 nm.	Toxins separated by HPLC. PDA detection with UV spectra of analytes.	Toxins separated by HPLC. Detection by MS or MS/MS.	Toxins separated by CE. Detection normally PDA or UV.	Microcystins oxidized whereby Adda side chain is converted to MMPB which is determined.
<b>What it measures</b>	Determines individual toxins, subject to availability of standards.	Determines individual toxins, subject to availability of standards.	Determines individual toxins. May assist in identification of particular toxins, but quantification still subject to availability of standards.	Determines individual toxins, subject to availability of standards.	Gives a sum total of microcystins, as microcystin-LR equivalents if microcystin-LR is used for calibration.
<b>Detection limit and precision</b>	Precision around 5-10%, consistent with robust HPLC techniques. Detection limit depends on concentration factor; 0.02 µg l <sup>-1</sup> estimated for individual toxins using 5 L sample.	Precision around 5-10%, consistent with robust HPLC techniques. Detection limit depends on concentration factor; 0.02 µg l <sup>-1</sup> estimated for individual toxins using 5 L sample.	Precision should be around 5-10%, consistent with robust HPLC techniques. Detection limit depends on concentration factor; 0.02 µg l <sup>-1</sup> for individual toxins using a 5 L sample.	Precision should be around 5-10%, consistent with robust HPLC techniques.	Detection limit of 0.43 ng microcystin. For water samples, detection limit depends on concentration factor.
<b>Current usage and reliability, i.e., is the current usage a research application only and is it amenable to routine use in a commercial laboratory?</b>	Common analytical technique routinely used. Reliability depends on correctly identifying microcystins.	Common analytical technique routinely used. Reliability depends on correctly identifying microcystins. Identification enhanced by spectral data.	Analytical technique becoming more common. Identification of microcystins from mass spectral data much more reliable.	Analytical technique becoming more common but not considered to yet be sufficiently robust for routine use. Even with PDA detection still uncertainties in identifying.	Amenable to routine monitoring. However results not in terms of what is required by guidelines.
<b>Degree of documentation of the method in the literature, i.e., are published standard protocols available?</b>	Well documented and reasonably well standardized.	Well documented and reasonably well standardized.	Not commonly used and therefore not well documented.	CE procedures not that common and therefore not well documented.	Reasonably well documented.
<b>Level of expertise required by the operator/analyst</b>	Moderate level of expertise. High level to correctly identify microcystins.	Moderate level of expertise to operate and to correctly identify microcystins.	Moderate level of expertise to operate and to correctly identify microcystins. Expertise required, should decrease with time.	Moderate level of expertise to operate and to correctly identify microcystins.	Moderate level of expertise.

### Appendix 9. Removal of hepatotoxins (microcystins) by water treatment processes

TREATMENT TECHNIQUE	RESULTS (REMOVAL %)		COMMENTS
	CELL BOUND	EXTRACELLULAR	
Coagulation/sedimentation/ dissolved air flotation	> 80%	< 10%	Removal only achievable for toxins in cells, provided cells are not damaged
Rapid filtration	> 60%	< 10%	Removal only achievable for toxins in cells, provided cells are not damaged
Slow sand filtration	~ 99%	<b>Probably significant</b>	Removal effective for toxins in cells
Combined coagulation/ sedimentation/filtration	> 90%	< 10%	Removal only achievable for toxins in cells, provided cells are not damaged
Dissolved air flotation	> 90%	<b>Not assessed, probably low</b>	Removal only achievable for toxins in cells, provided cells are not damaged
Adsorption – Powdered activated carbon (PAC)	<b>Negligible</b>	> 85%	For adequate PAC doses (>20mg l <sup>-1</sup> ) with a PAC shown to be effective, DOC competition will reduce capacity
Adsorption – Granular activated carbon (GAC)	> 60%	> 80%	For practical EBCTs, DOC competition will reduce capacity and hasten breakthrough, filtration also removes algal cells
Biological granular activated carbon	> 60%	> 90%	See GAC, biological activity enhances removal efficiency and bed life
Pre-ozonation	<b>Very effective in enhancing coagulation</b>	<b>Potential increase</b>	Useful in low doses to assist coagulation of cells; risk of toxin release requires careful monitoring and possibly subsequent treatment steps
Pre-chlorination	<b>Very effective in enhancing coagulation</b>	<b>Causes lysis and release of dissolved metabolites</b>	Useful to assist coagulation of cells but applicable for toxic cyanobacteria only if subsequent treatment steps will remove dissolved toxins and other released metabolites
Ozonation (post clarification)	-	> 98%	Rapid and efficient on soluble toxins provided that DOC demand is satisfied
Free chlorine (post filtration)	-	> 80%	Effective when free chlorine is >0.5 mg l <sup>-1</sup> after > 30 minutes at pH < 8 and low DOC, effect negligible when dose low or pH > 8
Chloramine	-	<b>Negligible</b>	Ineffective. Free chlorine application will yield ineffective chloramines in waters enriched with nitrogenous organic matter
Chlorine dioxide	-	<b>Negligible</b>	Not effective with doses used in drinking water treatment
Potassium permanganate	-	<b>95%</b>	Effective on soluble toxins but only in absence of whole cells
Hydrogen peroxide	-	<b>Negligible</b>	Not effective on its own
UV radiation	-	<b>Negligible</b>	Capable of degrading microcystin-LR and anatoxin-a, but only at impractically high doses
Membrane processes	<b>Likely to be very high (&gt; 99%)</b>	<b>Uncertain</b>	Depends on membrane type, further research required to characterize performance

Source: Adapted from Hrudey et al., 1999;

## ■ GLOSSARY AND MOST COMMONLY USED ABBREVIATIONS

**AEROBES** - organisms that can live only in aerobic conditions as they gain energy from the process of respiration.

**AGGREGATION** - the process of combining smaller spatial units into larger sets.

**ALGAE** - microscopic, usually unicellular, plants. Allochthonous - brought into a water body from outside.

**ALLOCHTHONOUS** organic matter - organic matter transported into a lake or river from adjacent ecosystems.

**ANAEROBES** - organisms living in anaerobic conditions and gaining energy from chemical reactions which are not based on oxygen transformations.

**ANALOGUE MAP** - map printed on paper using graphic symbols to represent features and values.

**ARC** - a line consisting of a series of vertices.

**ATTRIBUTE** - an alphanumeric characteristic of a geographic object (point, line, area) that can be stored in a relational database and linked by an identifier to an object.

**AUTOCHTHONOUS** - produced within a water body.

**BIOASSESSMENT (BIOASSAY)** - Uses biota as the endpoint to represent environmental conditions and assess environmental quality.

**BIODEGRADATION** - the gradual destruction of a material due to natural or artificially induced biological activity.

**BIOLOGICAL assessment (Bioassessment)** - an evaluation of the biological condition of a water body through the use of biosurveys and other direct measurements of resident biota in surface waters.

**BIOLOGICAL CRITERIA (BIOCRITERIA)** - numeric values or narrative expressions that describe the reference biological conditions of aquatic communities inhabiting waters that have been given a designated aquatic life use.

**BIOLOGICAL MONITORING (BIOMONITORING)** - the use of a biological entity as a detector and its response as a measure to determine environmental conditions. Biosurveys and toxicity tests are common biomonitoring methods.

**BIOLOGICAL SURVEY (BIOSURVEY)** - the process of collecting and processing representative portions of a resident aquatic community to determine the community membership, structure, and functions.

**BIOMANIPULATION** - all methods of changing biological structure of an ecosystem in order to improve water quality.

**BIOMASS** - the quantity of living organisms expressed in units of volume or mass, generally related to a unit of volume or area within a water body. Also organic material, usually plant or animal waste, especially used as fuel.

**BIOTEST** - biological test method using animals or plants to provide a measure of total toxicity of a compound.

**BIOTOPE** - populations of all species living in a particular space.

**BLOOMS** - high concentrations of phytoplankton biomass.

**BUFFER** - a zone of given radius around a geographical object (point, line, area).

**CARRYING CAPACITY** - the dynamic equilibrium around which a population fluctuates; regulated by available space and the amount (and quality) of available resources.

**CARTESIAN COORDINATE SYSTEM** - a system of two or three mutually perpendicular axes along which the location of any point can be precisely described by a set of (x,y,z) coordinates.

**CASCADING EFFECT** - transmission of changes within a given trophic level to lower ones.

**CHELATING** - capable of forming a ring-shaped molecular structure and locking a metal ion in place, thereby reducing their activity.

**CLEAR WATER PHASE** - period in spring (frequently in June) characterised by intensive consumption (maximal grazing rate) of filtering zooplankton on phytoplankton. As a consequence, phytoplankton are reduced to very low levels and water transparency increases sharply.

**CONTOUR** - a line connecting points of equal elevation (or other attribute).

**CYANOBACTERIA** [also Cyanophytes or blue-green algae] - a group of phytoplankton, some of which can produce toxins, regulate their depth using a gas-vacuole buoyancy mechanism, and/or fix atmospheric nitrogen for use in growth. They often occur in eutrophic waters as a bloom.

**CYANOTOXINS** - toxins produced by cyanobacteria and classified as: hepatotoxins, neurotoxins, dermatotoxins and lipopolisaccharides (LPS).

**DATA** - the basic element of information that can be processed by a computer; may be alphanumeric or graphical.

**DATA MODEL** - a formal method of arranging data to represent an observed environment.

**DATABASE** - a computer file containing data, organized, inter alia, as a set of tables or coordinates of the points and their attendant attributes.

**DENITRIFICATION** - the microbiologically-mediated reduction of oxygenated nitrogen compounds to gaseous nitrogen.

**DENITRIFYING BACTERIA** - the group of bacteria which utilize nitrate in one of three metabolic pathways:

- a) without accumulating nitrite,
- b) with transient accumulation of nitrite, and
- c) in a two-step denitrification process that transforms nitrate into gaseous nitrogen.

**DIATOMS** [also Bacillariophytes] - a group of algae with siliceous walls.

**DIGITAL TERRAIN MODEL (DTM)** - data which depict the relief of a given area of terrain using a grid or irregular triangular network and contour elevations.

**DIGITIZE** - a means of entering geographical data into computerized databases from analogue maps.

**DINOFLLAGELLATES** - a group of phytoplankton with flagella, or whip-like appendages, by which the organisms have limited movement.

**DIVERSITY OF FISH** - the proportion of a given fish species within a sample population. Diversity may be calculated using the Shannon Index (H), where:  $H' = - \sum p_i \ln p_i$ .  $p_i$  is the ratio of each component (the % of a given species) to the total value (all species=100%). The index may be scaled from 0 to 1, where 0 is the lowest possible diversity and 1 is the maximum possible diversity by dividing  $H'$  by  $\ln S$ , where  $S$  is the number of species having the indicated  $p_i$  value (after Odum 1980).

**ECOLOGICAL INTEGRITY** - the condition of the biotic (biological community) and abiotic (non-biological; water chemistry and habitat) components of unimpaired water bodies, as measured by assemblage structure and function, water chemistry, and habitat measures.

**ECOREGIONS** - a relatively homogeneous area defined by the similarity of climate, landform, soil, potential natural vegetation, hydrology, or other ecologically relevant variables.

**ECOTONE** - the transition zone between two different types of ecosystems, such as a river and a meadow, characterized by very high biodiversity; ecotones may play an important role as buffers, modifying and limiting flows of nutrients and pollutants between ecosystem components.

**EFFICIENT INFILTRATION** - the amount of precipitation water, which passes (percolates) from the unsaturated zone into the ground water. Efficient infiltration is sometimes called recharging infiltration.

**EH** - ecohydrology (see: chapter 2.A).

**ELISA** (enzyme-linked immunosorbent assay) - sensitive biochemical method for detecting compounds that interact with specific antibodies; useful for rapid sample screening for microcystins.

**ENTITY** - a discrete geographical object represented as a digital data structure.

**EX SITU** - removed from its original location.

**FEATURE** - a representation of a geographical object as a point, line, or polygon.

**FILTER** - a small matrix (mask) containing coefficients used for modifying pixel values in a raster image on a map using a variety of mathematical procedures.

**FLUORESCENCE** - the process whereby light is absorbed at one wavelength and almost instantaneously emitted at new and longer wavelengths by an organic molecule, as in the case of photosynthetic pigments.

**GENERALIZATION** - the reduction of the volume of geographical data; such reductions are usually used to construct a better graphical representation on a map or in image enhancement.

**GEOGRAPHIC OBJECT** - a user-defined part of the real world that can be represented using geographical features and attributes.

**GEOREFERENCE** - the relationship between raster data and cartographic coordinates.

**GREEN ALGAE** [also Chlorophytes] - a group of algae which are usually a good food for zooplankton.

**GRID DATA** - the structure of data used to represent geographical objects, composed of square cells of equal area, arranged in rows and columns.

**HEAT BALANCE** - balance of all energy fluxes entering and leaving an ecosystem or landscape.

**HPLC (high performance liquid chromatography)** - analytical method for separation and quantification of compounds in liquid solvents.

**IMAGE** - a graphic representation of an object produced by an optical or electronic device. An image is stored as raster data in the form of pixel values.

**IN SITU** - in the original location.

**IN VIVO** - in living organisms.

**INFILTRATION** - the slow passage of water (percolation), which comes from precipitation, rivers, water reservoirs and condensation of water vapour on soil, through the unsaturated zone to the saturated zone.

**INFILTRATION UNITS** could be:  $1 \text{ km}^2$  or  $\text{mm year}^{-1}$ .

**INTERPOLATION** - making predictions based on measurements done only in a certain area.

**IWM** - Integrated Watershed Management.

**KRIGING** - an interpolation technique based on a theory of the semivariogram.

**LAYER** - a logical set of thematic data covering one subject.

**MAP PROJECTION** - a set of mathematical equations for converting geographical coordinates to Cartesian plane coordinates. The equations allow the depiction of spherical, three-dimensional objects on a flat map.

**METRICS** - a characteristic that changes in some predictable way with increased human influence (e.g., a scoring system).

**MIDSUMMER DECLINE** - sudden midsummer decrease of large, filtering zooplankton (mainly *Daphnia* spp.) biomass.

**MODEL** - a simplification and abstraction of reality. Models can be seen as a data set representing the structure of geographical objects, as well as a set of logical expressions and mathematical equations used to simulate processes. Models may also be physical representations of geographic features.

**MULTIMETRIC APPROACHES** - an analysis technique using several measurable characteristics of a biological assemblage.

**MULTISPECTRAL** - the remote sensing technique for obtaining images over a number of distinct narrow bands of the electromagnetic spectrum.

**MULTIVARIATE COMMUNITY ANALYSIS** - statistical methods (e.g., ordination or discriminant analysis) for analyzing physical and biological community data using multiple variables (quantitative or nominal).

**NODE** - the end points of a line.

**NON-POINT SOURCE POLLUTION** - pollution entering water bodies from diffused sources, including surface and subsurface runoff, nutrient leaching, and erosion, mainly from degraded landscapes (e.g., landscapes degraded due to agriculture, deforestation, etc.).

**NUTRIENT CONCENTRATION** - the amount of a nutrient in a given volume of water.

**NUTRIENT LOAD** - the amount of a nutrient transported into a water body by rivers, sewage discharges, etc., over a given period of time, calculated as concentration multiplied by discharge.

**NUTRIENTS** - chemical elements necessary for growth and development of vegetation. The main nutrients are phosphorus, nitrogen, and carbon. Increased nutrient concentrations stimulate the process of eutrophication in aquatic ecosystems.

**PH** - phytotechnology (see chapter: 2.B).

**PHOSPHATASE** - a group of hydrolytic enzymes liberating the orthophosphate ion from organic compounds.

**PHYCOCYANIN** - a photosynthetic pigment characteristic of cyanobacteria.

**PHYTOEXTRACTION** - removal of chemical substances by plants.

**PHYTOPLANKTON** - the algal component of plankton, which are free-living organisms within an aquatic environment.

**PHYTOREMEDIATION** - removal of contamination through the natural process of plant uptake.

**PIEZOMETER** - a pipe-like trap for ground waters with perforated ends, placed in water bearing layers to measure ground water elevations; when placed in fields, ground water flows can be measured using tracers.

**PIXEL** - one picture element (or cell) in a set of grid data.

**POINT SOURCE POLLUTION** - pollution entering water bodies from concentrated outflows (e.g., pipes transporting municipal and industrial sewage, water from purification plants, irrigation channels, etc.).

**POLYGON** - a vector representation of an enclosed area written as a set of vertices or given by a mathematical function.

**PPIA (protein phosphatase inhibition assay)** - sensitive biochemical method that uses biochemical activity to measure the presence of microcystin and nodularin toxins.

**PYROLYSIS** - the breaking apart of complex molecules into simpler units by the use of heat.

**RADICAL ZONE** - the surface layers of the soil within the reach of plant roots.

**RASTER** - a computer readable format used for representing images or grid data.

**RASTERIZATION** - the process of converting data from vector format to raster format.

**REFERENCE CONDITION** - the chemical, physical, or biological quality, exhibited at either a single site or an aggregation of sites, representing a semi-natural or reasonably attainable condition at the least impaired reference sites.

**REFLECTANCE** - the ratio of energy reflected by a surface to that incident upon it.

**RETENTION TIME** [also Water retention time, WRT] - the ratio of volume and flow of a reservoir or lake.

**RETENTION TIME, WATER RETENTION TIME** - the ratio of volume and flow of a reservoir or lake.

**RTS** - (river type-specific species) - criterion reflects the fish fauna naturally occurring in a specific type of river, excluding species not native in a given area (e.g., country, ecoregion) and not autochthonous for that river.

**RUBBER SHEETING** - the procedure for adjusting the geometry of an image by non-uniform transformations.

**SCALE** - a relationship between the distance on a map and in reality.

**SCANNING** - the process by which analogue maps are converted to raster format by an optical device.

**SEMIVARIOGRAM** - a graph showing the relationship between variance and separation for a pair of data points.

**SHELTERBELT** - a row of trees and shrubs planted in the midst of a cultivated field.

**SHOAL** - a large number of fish swimming together.

**SPATIAL INTERPOLATION** - the procedure of estimating values in certain areas using existing observations.

**SSP** - species criterion reflects the type-specific fauna (RTS-species) composed of species meeting the following minimum criteria: the species are self-reproducing, thus juvenile fishes occur, and maintain, at least a minimum population size.

**STABILIZATION** - a process designed to limit the mobility of toxic chemicals.

**STREAM MICROHABITAT SYSTEM** - the distribution of pools, riffles, and runs, having relatively homogenous substrate types, water depths, and velocities, within a stream course.

**STREAM ORDER** - the dendritic arrangement of channels of a river throughout its drainage basin. The most popular hierarchy is defined such that first order streams are those having no tributaries, second order streams are those formed by the union of two first order streams, third order streams are those formed by the union of second order streams, and so on.

**STREAM POOL-RIFFLE-RUN SYSTEM** - a subsystem of a reach having characteristic bed topography, water surface slope, depth, and velocity patterns. In a natural meandering watercourse, the shallow zones or riffles and the deeper zones or pools lie in a regular pattern connected by runs. The distance between two neighbouring riffles or pools is approximately one half of the wavelength of one full meander, or about 5 to 7 times the width of a watercourse. In-stream habitats at this level are complex hydrological units.

**STREAM REACH** - a length of stream or a stream segment lying between breaks in channel slopes, local side slopes, valley floor widths, riparian vegetation, and bank materials.

**STREAM SEGMENT** - the portion of a stream system flowing through a single bedrock type and bo-

unded by tributary junctions or major waterfalls.

**STREAM SYSTEM** - all running surface waters in a watershed and standing waters within stream systems that may be wetlands or lakes depending upon their depth, hydrologic conditions, soil types, and vegetation cover.

**SUCCESSION** - is a widely-accepted, biological concept implying a sequence in which species or groups of species dominate a plant community.

**SUCCESSION** - the biological concept implying a sequence in which species or groups of species, dominate a community.

**SURFACE** - a representation of geographical object as a set of continuous data (also a data field). Surface runoff - surface flow caused by rainfall, transporting solids, nutrients, and pollutants downhill into aquatic systems.

**THE SATURATED ZONE** - is the zone below the groundwater table where all pores are filled by water.

**THE UNSATURATED ZONE** - is the zone immediately below a land surface and above a water table where pores contain both water and air and are not totally saturated with water. The unsaturated zone is sometimes called the vadose zone.

**TOPOLOGY** - the spatial relationship between nodes, lines, and polygons.

**TREATABILITY STUDY** - a study to determine the efficiency of one or more potential treatment methods or processes for a given remediation problem.

**VECTOR** - a data structure in which lines are represented as a list of ordered coordinates.

**VECTORIZATION** - the process of converting data from raster to vector formats.

**VERTEX (VERTICES)** - a point or series of points with given coordinates on a line.

**WATER BALANCE** - balance sheet of all water fluxes entering and leaving an ecosystem or landscape.

**WATER DEFICIT** - difference between evapotranspiration and water supplies (precipitation and water retention) within agricultural landscapes.

**WETLAND** - a natural or constructed system, permanently or periodically flooded, that can act as water purification systems or nutrient sinks. Purification is enhanced by the activity of vegetation and variety of microbiological and biogeochemical processes taking place within the substrate of the wetland. Wetlands are defined by the presence of hydric soils, characteristic types of vegetation, and a high water table.



## ■ REFERENCES

- Agoshtino A. A., Gomez L. C., Zalewski M.** 2001. The importance of floodplains for dynamics of fish communities of upper river Parana In International Journal of Ecohydrology & Hydrobiology Catchment processes land/water ecotones and fish communities (ed) Zalewski M. Scheimer F. Thrope J. Vol. 1 no 1-2 209-219
- Alloway B. J.** 1995. Heavy metals in soils. 2nd ed., Chapman & Hall, Glasgow. 340 pp.
- Amarasinghe P. B.,** Boersma M. & Vijverberg J. 1997. The effect of temperature, and food quantity and quality on the growth and development rates in laboratory-cultured copepods and cladocerans from a Sri Lankan reservoir. *Hydrobiologia* 350: 131-144.
- An, J.S. & Carmichael W.W.** 1994. Use a colorimetric protein phosphatase inhibition assay and enzyme linked immunosorbent assay for study of microcystins and nodularins. *Toxicon* 32: 1495-1507.
- Andersen T., Hessen D. O.** 1991. Carbon, nitrogen and phosphorus content of freshwater zooplankton. *Limnology and Oceanography* 36: 807-814.
- Anderson J. R.** 1993. State of the Rivers Project. Report 1. Development and Validation of the Methodology. Department of Primary Industries, Queensland.
- Angermeier P. L.,** Karr J. R. 1986. Applying an index of biotic integrity based on stream fish communities: considerations in sampling and interpretation. *North American Journal of Fisheries Management* 6:418-429.
- Azcón-Aguilar C. Barea J.M. 1992. Interactions between mycorrhizal fungi and other rhizosphere microorganisms. In: Allen MJ (Ed) Mycorrhizal functioning. An integrative plant-fungal process. Routledge, Chapman & Hall Inc., New York, pp. 163-198
- Azcón-Aguilar C. Barea J.M.** 1992. Interactions between mycorrhizal fungi and other rhizosphere microorganisms. In: Allen MJ (Ed) Mycorrhizal functioning. An integrative plant-fungal process. Routledge, Chapman & Hall Inc., New York, pp. 163-198
- Balon E.K.** 1975. Reproductive guilds of fishes: A proposal and definition. *J.Fish.Res.Board Canada* 32, 821-864.
- Balon E. K.** 1981a. Reproductive guilds and the ultimate structure of fish taxocenes: amended contribution to the discussion presented at the mini-symposium. *Environmental Biology of Fishes* 3: 149-152.
- Balon E. K.** 1981b. Additions and amendments to the classification of reproductive styles in fishes. *Environmental Biology of Fishes* 6: 377-389.
- Baird, A.J., Wilby R.L. (eds.)** 1999. Eco-hydrology . Plants and water in terrestrial and aquatic environments. Routledge, London, New York. 402pp
- Barbour M. T.,** Gerritsen J., Snyder B. D. & Stribling J. B. 1999. Rapid bioassessment protocols for use in streams and wadeable rivers: periphyton, benthic macroinvertebrates and fish. 2nd ed. EPA 841-B-99-002. U.S. Environmental Protection Agency, Office of Water, Washington.
- Bartoszewicz A.** 1990. Chemical composition of ground waters in agricultural watershed under the soil and climate conditions of Kołecian Plain. p: 127-142 In: Obieg wody i bariery biogeochemiczne w krajobrazie rolniczym (L. Ryszkowski, J. Marcinek & A. Kedziora, eds.). Wydawnictwo Naukowe Uniwersytetu A. Mickiewicza, Poznan (In Polish).
- Bartoszewicz A.** 1994. The chemical compounds in surface waters of agricultural catchments under the soil weather conditions of the Koscian lowland. *Roczniki Akademii Rolniczej w Poznaniu* 25: 5-68. (in Polish)
- Bartoszewicz A., Ryszkowski L.** 1996. Influence of shelterbelts and meadows on the chemistry of ground water. 98-109 In: Dynamics of an agricultural landscape (L. Ryszkowski, N. R. French & A. Kedziora, eds). Zaklad Badan Srodowiska Rolniczego i Lesnego PAN, Poznan.
- Bateman, K.P., Thibault, P., Douglas, D.J. & White, R.L.** 1995. Mass spectral analyses of microcystins from toxic cyanobacteria using on-line chromatographic and electrophoretic separations. *J. Chromatogr. A*, 712: 253-268.
- Bazan J.** 1998. Seasonal changes of phosphorous concentration in different macrophytes species. MSc Theses. University of Lodz (in Polish).
- Bednarek A., Zalewski M., Blaszczyk M., Dabrowska E., Czerwiec E. & Tomaszek J.** 2001. Denitrification processes in bottom sediment of the Sulejow Reservoir - comparison two methods. *Postep w Inzynierii Srodowiska, II Ogolnopolska Konferen. Naukowo-Techn., Rzeszow-Polanczyk* 203-211. (in Polish)

- Bernatowicz S., Wolny P.** 1974. Botany for fishery science. PWRiL., Warszawa. (in Polish)
- Berz G. A.** 2001. Climate change: Effects on possible responses by the insurance industry. 392-399 In: Climate of the 21st century (J. L. Lozan, H. Gral & P. Hupfer, eds). Hamburg.
- Blaylock M.J., Zakharova O., Salt D.E., Raskin I.** 1995. Increasing heavy metal uptake through soil amendments. The key to effective phytoremediation. In: Agronomy abstracts. ASA, Madison, WI, p. 218
- Bloomfield C.** 1981. The translocation of metals in soils. In: Greenland D.J., Hayes MHB (ed.) The Chemistry of Soil Processes. John Wiley & Sons Ltd, Chichester.
- Boon P. J., Wilkinson J. & Martin J.** 1998. The application of SERCON (System for Evaluating Rivers for Conservation) to a selection of rivers in Britain. Aquatic Conservation: Marine and Freshwater Ecosystems 8: 597-616.
- Boyt F. L., Bayley S. E. & Zoltek J. Jr.** 1977. Removal of nutrients from treated municipal wastewater by wetland vegetation. J. Water Poll. Cont. Fed., 49 (5): 789-799.
- Brierley G., Fryirs K. & Cohen T.** 1996. Development of a generic geomorphic framework to assess catchment character. Part 1. A geomorphic approach to catchment characterisation. Working Paper 9603, Graduate School of the Environment, Macquarie University
- Brummer G. W., Gerth J. & Herms U.** 1986. Heavy metal species, mobility and availability in soils. Z.Pflanzenernaehr.Bodenk. 149:382-398.
- Burzynska H.** 1964: Methods of detection and identification rod-bacterium in group Pseudomonas-Achromobacter and similar. Roczniki PZH 15: 171-181. (in Polish)
- Byczynski H., Blaszczyk T. & Witczak S.** 1979. Pollution hazards and protection of groundwater. Wydawnictwo Geologiczne Warszawa. (in Polish)
- Calow P., Petts G.E.** (eds). 1992. The Rivers Handbook. Volume One. Hydrological and Ecological Principles. Blackwell Science Ltd, 526 pp.
- Carmichael W. W.** 2001. Health effect of toxin-producing Cyanobacteria: „The CyanoHABs”. Human and Ecological Risk Assessment 7: 1393-1407.
- Carpenter S. R., Kitchell J. F. & Hodgson J. R.** 1985 - Cascading trophic interactions and lake productivity - BioScience 35: 634-639.
- CEN/TC 230/WG 2/TG 4 N 27.** 2002. Work Item 230116, Water analysis Sampling of fish with electricity.
- Chessman B., Nancarrow J.** 1999. Draft pressure-biota-habitat stream assessment. Report on Adelong Creek field trial. New South Wales. Department of Land and Water Conservation, Sydney.
- Chicharo L.M, Chicharo M.A.** (1995). The RNA/DNA ratio as a useful indicator of the nutritional condition in juveniles of *Ruditapes decussatus*. SCI MAR 59, Suppl. 1: 95-101
- Chicharo M.A., Chicharo L, Valdes L, López-Jamar E., Ré P.** (1998). Estimation of starvation and diet variation of the RNA/DNA ratios in field-caught *Sardina pilchardus* larvae off the north of Spain Mar. Ecology Progress Ser 164: 273-283 1998
- Chicharo M.A., Esteves E, Santos AMP, dos Santos A, Peliz A, and Ré P.** (2003) Nutritional condition, growth and food availability of sardine larvae during a winter upwelling event off northern Portugal. Mar. Ecology Progress Ser. 257: 303-309
- Chikita, K.A.** 1996. Suspended sediment discharge from snowmelt: Ikushunbetsu River, Hokkaido, Japan. J. Hydrol., 186: 295-313.
- Chlapowski D.** 1943. Abot Agriculture. O rolnictwie. Druk Walentego Stefanskiego. Poznan. 164 (In polish)
- Chmielewski, T. J.** 2001. Spatial Planning system as a tool for harmonization of nature and management. Politechnika Lubelska. 290pp. (in Polish)
- Chorus I., Bartram J.** 1999. Toxic cyanobacteria in water. A Guide to their public health consequences, monitoring and management. E&FN Spon, London.
- Chorus I.** 2001. In: I. Chorus, (Ed.), Cyanotoxins. Occurrence, causes, consequences: Springer-Verlag Berlin Heidelberg, Germany.
- Ciolkosz. A., Miszalski, J., Oledzki, J.R.,** 1999. Interpretation of aerial photograph. Interpretacja zdjęć lotniczych. Wydawnictwo Naukowe PWN. Warszawa. (in polish)
- Clarke, K. & Warwick R.** (2001). Change in marine communities: an approach to statistical analysis and interpretation. 2nd edition. PRIMER-E:Plymouth

- Cloern, J.E.** 1987. Turbidity as a control on phytoplankton biomass and productivity in estuaries: Continental Shelf Research, v. 7, no. 11/12, p. 1367-1381.
- Codd, G.A.**, 2000. Cyanobacterial toxin, the perception of water quality, and the prioritisation of eutrophication control. *Ecological Engineering* 16: 51-60.
- Cowx I.G., Lamarque P.** (eds). 1990. Fishing with Electricity. Applications in Freshwater Fisheries Management. Fishing News Books. 248 pp.
- Cowx I. G., Welcomme R. L.** 1998. Rehabilitation of rivers for fish. Fishing News Books. Oxford.
- Cox G. & Tinker B.B.** 1976. Translocation and transfer of nutrients in vesicular-arbuscular mycorrhizas I. The arbuscule and phosphorus transfer: quantitative ultrastructural study. *New Phytologist* 77: 371-378.
- Dahl B. E. & Fall B. A.** 1975. Construction and Stabilization of Coastal Foredunes With Vegetation: Padre Island, Texas. U.S. Army Corp of Engineers, Coastal Engineering Research Center. MP9-75: 51-174
- Daily, G.C., Soderquist, T., Aniyar, S., Arrow, K., Dasgupta, P., Ehrlich, P.R., Folke, C., Jansson, A., Jansson, B., Kautsky, N., Levin, S., Lubchenco, J., Maler, K., Simpson, D., Starett, D., Timan, D., Walker, B.**, 2000. The Value of Nature and the Nature of Value. *Science* 289:395-396
- Day, J. H.** 1980. What is an estuary? *South African Journal of Science*. 76: 198.
- Day, J. H.** 1981. The nature, origin and classification of estuaries. In Day, J. H. (Ed.) *Estuarine Ecology with Particular Reference to Southern Africa*. Cape Town, A.A. Balkema. pp. 1-6.
- De Walle, D. R., B. R. Swistock, W. E. Sharpe.** 1991. Tracer model for Storm flow on a small Appalachian forested catchment - reply. *J. Hydrol.*, 117: 377 - 380.
- Dowgiallo J., Kleczkowski A., Macioszczyk T. & Rozkowski A.** (eds.). 2002, *Hydrological Dictionary*. Państwowy Instytut Geologiczny. Warszawa. (in Polish)
- Dunn H.** 2000. Identifying and protecting rivers of high ecological value LWRDC Occasional Paper No.01/00.
- Edwards, C., Lawton, L.A., Beattie, K.A., Codd, G.A., Pleasance, S., & Dear, G.J.** 1993. Analysis of microcystins from cyanobacteria by liquid chromatography with mass spectrometry using atmospheric-pressure ionisation. *Rapid Commun. Mass Spectrom.* 7: 714-719.
- Ek van R., Witte J.-P. M., Runhaar Klijn F.** 2001. Ecological effects of water management in the Netherlands; the model DEM-NAT, In: *Ecological Engineering* Vol. 16, No 1 127-143
- Elser J. J., Urabe J.** 1999. The stoichiometry of consumer-driven nutrient recycling: theory, observations, and consequences. *Ecology* 80: 735-751.
- Falconer, I.R.** 2001. Toxic cyanobacterial bloom problems in Australian waters: risks and impacts on human health. *Phycologia* 40: 228-233.
- Falconer, I.R., Jackson, A.R.B., Jangley, J. & Runnegar, M.T.** 1981. Liver pathology in mice in poisoning by the blue-green alga *Microcystis aeruginosa*. *Aust. J. Biol. Sci.* 34: 179-187.
- FAME project.** 2001-2004. Development, Evaluation and Implementation of a Standardised Fish-based Assessment Method for the Ecological Status of European Rivers. A Contribution to the Water Framework Directive (acronym: FAME). Research project contract no. EVK1-CT-2001-00094 supported by the European Commission under the Fifth Framework Programme, key action: Sustainable Management and Quality of Water within the Energy, Environment and Sustainable Development Programme (project co-ordinator S.Schmutz). [www.fame.boku.ac.at](http://www.fame.boku.ac.at). FAO/Unesco.
1973. *Irrigation, Drainage and Salinity: An International Source Book*. London: Hutchinson&Co.
- Faush K. D., Lyons J., Karr J.R. & Angermeier P. L.** 1990. fish communities as indicators of environmental degradation. *American Fisheries Society Symposium* 8:123-144.
- Fink J.**, 1963, *Introduction to biochemistry of plant phosphorous*. Wstep do biochemii fosforu roslin, Państwowe Wydawnictwo Rolnicze i Lesne, Warszawa, str. 241 (in polish)
- FISRWG 10.** 1998. *Stream Corridor Restoration: Principles, Processes, and Practices*. The Federal Interagency Stream Restoration Working Group (FISRWG) GPO Item 0120-A; SuDocs No. A 57.6/2:EN3/PT.653. [http://www.usda.gov/stream\\_restoration](http://www.usda.gov/stream_restoration).

- Fladmark, K.E., Serres, M.H., Larsen, N.L., Yasumoto, T., Aune, T. & Doskeland, S.O.**, 1998. Sensitive detection of apoptogenic toxins in suspension cultures of rat and salmon hepatocytes. *Toxicol* 36: 1101-1114.
- Flury, T., Heinze, R., Wirsing, B., Fastner, J., Neumann, U. & Weckesser, J.** 2001. Comparative Evaluation of Methods for Assessing Microcystin Concentrations with a Variety of Field Samples. p: 330-339 In: I. Chorus et al. (Eds), *Cyanotoxins. Occurrence, Causes, Consequences*. Springer, Berlin, Germany.
- Franklin I. R.** 1980. Evolutionary change in small populations. p: 135-149 In *An Evolutionary-Ecological Perspective* (M. E. Soulé, B. A. Wilcox, eds), Sinauer, Sunderland Mass.
- Frissell C. A., Liss W. J., Warren C. E. & Hurley M. D.** 1986. A hierarchical approach to classifying stream habitat features: viewing streams in a watershed context. *Environmental Management* 10: 199-214.
- Galicka, W.** 1993. Inflow of various forms of nitrogen to the Sulejów Reservoir in the years 1981-1984. *Pol. Arch. Hydrobiol.* 40. 2: 119-138.
- Gamble T. N., Betlach M. R. & Tiedje J. M.** 1977: Numerically dominant denitrifying bacteria from world soils. *Applied Environmental Microbiology* 33: 926-939.
- Genereux, D., H. F. Hemond.** 1990. Three component tracer model for stormflow on a small Appalachian catchment - comment. *J. Hydrol.*, 117: 377 - 380.
- Gibert J. , Mathieu J., Fournier F., [eds]** 1997. *Groundwater/Surface Water Ecotones: Biological and Hydrological Interaction and Management Options UNESCO, International Hydrology Series*, Cambridge University Press
- Goldstein R. M., Simon T. P.** 1999. Toward a United Definition of Guild Structure for Feeding Ecology of North American Freshwater Fishes. P: 123-220 In: *Assessing the Sustainability and Biological Integrity of Water Resources Using Fish Communities*. (T.P. Simon, ed.) CRC Press. Boca Raton, USA.
- Goldyn R., Grabia J.** 1996. Concept of application of natural method in purification of pollutants from Jarocin. [W:] Kraska M., Blazjewski R. (red.), *Oczyszczalnie hydrobotaniczne, II Międzynarodowa Konferencja Naukowo-Techniczna, Poznan, 2-3 wrzesnia 1996.* (in polish)
- Goryczko K.** 1999. Water pollution through trout fisheries - treatment methods. In: *Salmonid fish culture and its influence on surface waters quality. Instructional papers.* Gdanska Fundacja Wody, Gdansk, 8 pp. (in Polish)
- Gunderson L. H.** 1989. Historical Hydropatterns in wetland Communities of Everglades National Park. p: 1099-1111 In: *Freshwater Wetlands and Wildlife*. (R. R. Sharitz, J. W. Gibbons, eds.) Oak Ridge, TN U.S.
- Harada K-I.** 1996. Chemistry and Detection of Microcystins. p: In: *Toxic Microcystis* (M. F. Watanabe, K. I. Harada, W. W. Carmichael & H. Fujiki, eds). CRC Pres. Inc., London.
- Harada K-I.** 2000. Chemistry and detection of microcystins In: (Eds) Watanabe M.F., Harada K.-I., Carmichael W.W., Fujiki H. *Toxic Microcystis*. CRC Press Inc., Florida, p. 103-148.
- Harley J.L., Harley E.L.** 1987. A check list of mycorrhiza in British flora. *New Phytol.* 105(2): 1-102.
- Harper D.** 1992. *Eutrophication of Freshwaters. Principles, problems and restoration.* London-New York, Chapman and Hall.
- Harris R. P., Wiebe P. H., Lenz J., Skjoldal H. R. & Huntley M.** 2000. *ICES Zooplankton Methodology Manual.* Academic Press, . 667 pp.
- Haycock N. E., Burt T. P., Goulding K. W. T. & Pinay G. (eds).** 1997. Buffer zones: their processes and potential in water protection. *Quest Environmental.* Harpenden, U.K. 326 pp.
- Herman, P.M.J., and Scholten, H.** 1990. Can suspensionfeeders stabilise estuarine ecosystems? In *Trophic Relationships in the Marine Environment*, eds. M. Barnes and R.N. Gibson, pp. 104-116. Aberdeen, UK: Aberdeen University Press.
- Hillbricht-Ilkowska A., Ryszkowski L. & Sharpley A.N.** 1995. Phosphorus transfers and landscape structure: riparian sites and diversified land use patterns. p: 201-228 In: *Phosphorus in a global environment*. (H. Tiessen, ed.) SCOPE.
- Hodgkin, E. & Birch, P.** 1998. No simple solutions: Proposing radical management options for an eutrophic estuary. *Marine Pollution Bulletin*, 17(9): 399-404.
- Hrudey, S., Burch, M., Drikas, M. & Gregory, R.** 1999. In: I. Chorus & J. Bartram, (Eds.), *Toxic Cyanobacteria in Water: A Guide to Their Public Health Consequences, Monitoring, and Management*. E & FN Spon, London.

- Huet M.** 1949. Aperçu des relations entre la pente et les populations des eaux courantes. *Schweizerische Zeitschrift für Hydrologie* 11, 333-351.
- Hutchinson, G.E.** 1961. Paradox of the plankton. *American Naturalist* 95:137-145.
- Illies J., Botosaneanu L.** 1963. Problemes et methodes de la classification et de la zonation ecologique des eaux courantes, considerees surtout de point de vue faunistique. *Mitt. Internat. Verein. Theoret. Angew. Limnol.* 12: 1-57.
- Imhoff K., Imhoff K. R.** 1982. City canalisation and sewage treatment. *Guideline*. Arkady, Warszawa, . 382 pp. (in Polish):
- IPCC.** 1996. *Impacts, Adaptation, and Mitigation of Climate Change*. Cambridge University Press, 469-486
- IPCC.** 2001. *Impacts, Adaptation and Vulnerability*. Cambridge University Press, 193-233
- ISO/CD 10381 - 5.** Soil quality - sampling.
- ISO/DIS 11464.** Soil quality Pretreatment of samples for physical-chemical analyses
- Jackson, A.R.B., Innes M.C. & Falconer, I.R.** 1984. Clinical and pathological changes in animals experimentally poisoned by *Microcystis aeruginosa*. *Vet. Pathol.* 21: 102-123.
- Jenssen R.** 1972. Taking care of wasters from the trout farm. *Am. Fishes U.S. Trout News*, 17: 4 - 21.
- Jeziarska - Madziar M., Pinskiwar P.** 1998. Intensification of fishery production and protection of environment *Intensyfikacja produkcji rybackiej a ochrona srodowiska*. p: 33 - 40 In: 3rd Carp Producers National Conference, Kazimierz Dolny, 12-14.03.1998. IRS, Olsztyn. (in Polish)
- Johnson R. K.** 2001. Indicator metrics and detection of impact. p: 41-44 In *Monitoring and assessment of ecological status of aquatic environments*. (K. Karttunen, ed.) Nordic Council of Ministers, TemaNord 563
- Jones G.** 1996. *Toxic algae study summary*. Manitoba Department of Environment.
- Jorgensen, S.E.** 1996. The application of ecosystem theory in limnology. *Verh. Int. Verein Limnol.* 26, 181-192.
- Jungwirth M., Muhar S. & Schmutz S.** 1995. The effects of recreated instream and ecotone structures on the fish fauna of an epipotamal river. *Hydrobiologia* 303: 195-206.
- Kadlec R. H., Knight R. L.** 1995. *Treatment Wetlands*. Lewis Publishers, USA.
- Karg J., Ryszkowski L.** 1996. Animals of arable land. p: 138-172 In: *Dynamics of an agricultural landscape* (L. Ryszkowski, N. R. French & A. Kedziora, eds). Zaklad Badan Srodowiska Rolniczego i Lesnego PAN, Poznan.
- Karpinski A.** 1999. Generating and treatment of intensive salmonid fish farm effluent In: *Salmonid fish culture and its influence on surface waters quality*. Instructional papers. Gdanska Fundacja Wody, Gdansk. 8 pp. (in Polish)
- Karr J. R.** 1981 Assessment of biotic integrity using fish communities. *Fisheries Bethesda* 6: 21-27.
- Karr J.R., Fausch K. D., Angermeier P. L., Yant P. R & Schlosser I. J.** 1986. Assessing biological integrity in running waters: a method and its rationale. *Illinois Natural History Survey, Special Publication* 5, 28 pp.
- Kedziora A.** 1996. Hydrological cycle in agricultural landscapes. In: *Dynamics of an agricultural landscape*. p: 65-78 In: (L. Ryszkowski, N. French & A. Kedziora, eds.) PWRiL, Poznan
- Kerepeczki E., Pekar F.** 2003. Treatment of intensive fish farm effluent in polyculture fishponds and wetlands. In: *Beyond Monoculture* (T. Chopin, H. Reinertsen, eds.). EAS Special Publication 33: 220 - 221.
- Keyfitz N.** 1992. *Science Fragmented*. Options. IASA.
- Kiedrzynska E.** 2001. Comparison of Nutrient Deposition Rate in the Pilica River Floodplain of Different Typology. Msc. Thesis. *Tempo asymilacji fosforu przez roslinnosci zroznicowanych typologicznie obszarów zalewowych doliny Pilicy*; [typescript] (In polish)
- Kiviranta, J., Abdel-Hameed A.** 1994. toxicity of the blue-green alga *Oscillatoria agardhii* to the mosquito *Aedes aegypti* and the shrimp *Artemia salina*. *World J. Microbiol. Biotechnol.* 10: 517-520.
- Kiviranta J.** 1992. Larvicidal effect of toxic cyanobacteria on yellow fever mosquito *Aedes aegypti*. *Acta Pharmaceutica Fennica* 101: 83-87.
- Klosowski S.** 1993. The shore vegetation in selected lakeland areas in northeastern Poland. *Hydrobiologia* 251: 227-237.

- Knoeshe R., Schreckenbach K., Pfeifer M., Weissenbach H., Jannurik E. & Szabo P.** 2003. Nutrient balance of carp ponds and pathways of nutrient load. p: 226 - 227 In: Beyond Monoculture. (T. Chopin, H. Reinertsen, ed.) EAS Special Publication 33.
- Koc J. i Polakowski B.**, 1990. Charakterystyka zaglebień bezodpływowych na Poj. Mazurskim w aspekcie przyrodniczym, urządzeniowo rolnym i rolniczym. [W:] Użytki ekologiczne w krajobrazie rolniczym, SGGW, Warszawa: 25-57.
- Kondo, F., Ikai, Y., Oka, H., Ishikawa, N., Watanabe, M.F., Watanabe, M., Harada, K-I. & Suzuki, M.** 1992. Separation and identification of microcystins in cyanobacteria by frit-fast atom bombardment liquid chromatography/mass spectrometry. *Toxicon* 30: 227-237.
- Korc M.** et al. 2002. GIS development-site description in: WELCOME - EUK1-2001-00132 WP 4.1 - GIS description - unpublished report, IETU.
- Koske R.E, Sutton J.C., Sheppard B.R.** 1975. Ecology of Endogone in Lake Huron sands dunes. *Can. J. Bot.* 53: 87-93.
- Kreeger D. A & C. J. Langdon** 1993. Effect of Dietary Protein Content on Growth of Juvenile Mussels, *Mytilus trossulus* (Gould 1850). *Biol Bull* 1993 185: 123-139.
- Kucharski R., Sas-Nowosielska A., Malkowski E. & Pogrzeba M.** 1998. Report prepared for the U.S Department of Energy. Integrated approach to the remediation of heavy metal-contaminated land. IETU Katowice.
- Kucharski R., Marchwinska E. & Gzyl J.** 1994. Agricultural policy in polluted areas. *Ecological Engineering* 3: 299-312
- Kucharski R., Nowosielska A.** 2002. A Decision Support System to Qualify Cost/Benefit Relationship of the Use of Vegetation in the Management of Heavy Metal Polluted Soils and Dredged Sediments. Draft annual report. EVK1-1999-00116.
- Kumar P., Duschenkov V., Motto H., Raskin I.** 1995. Phytoextraction: The use of plants to remove heavy metals from soils. *Environm Sci Technol* 29:1232-1238.
- Kyselkova, I. & Marsalek, B.** 2000. Use of *Daphnia pulex*, *Artemia salina* and *Tubifex tubifex* for cyanobacterial microcystin detection. *Biologia* 55: 637 - 643.
- Lambert, T.W., Boland, M.P., Holmes, C.F.B. & Hrudehy, S.E.** 1994. Quantitation of the microcystins hepatotoxins in water at environmentally relevant concentrations with the protein phosphatase bioassay. *Environ. Sci. Technol.* 28: 735-755.
- Lamshead, P. J. D., Platt, H. M., and Shaw, K. M.** 1983. The detection of differences among assemblages of marine benthic species based on an assessment of dominance and diversity. *J. Nat. Hist.* 17:859-874.
- Landolt E., Kandeler R.**, 1986. The family of Lemnaceae-amonographic study. *Verffentlichungen Geobot. Inst. ETH, Stiftung R(ebel, Z(rich.vol .2.*
- Lapinska M., Kaczkowski Z., Zalewski M.** 2002. Restoration of streams for water quality improvement and fishery enhancement, s.113-125. In: M. Zalewski (red.) "Guidelines for the Integrated Management of the Watershed - Phytotechnology and Ecohydrology. United Nations Environment Programme, Division of Technology, Industry and Economics. Freshwater Management, Series No.5, 188 s.
- Lawton L. A., Edwards C. & Codd G. A.** 1994. Extraction and high-performance liquid chromatographic method for the determination of microcystins in raw and treated waters. *Analyst.* 119: 1525-1530.
- Lechat B.** 1991. Le cours d'eau. Conservation, entretien et aménagement. Serie aménagement et gestion no 2, Strasbourg
- Lenz J.** 1992. Microbial loop, microbial food web and classical food chain: their significance in pelagic marine ecosystems. *Archiv fur Hydrobiologie, Beiheft, Ergebnisse der Limnologie* 37: 265-278.
- Lewis,** 1995. Use of Freshwater Plants for Phytotoxicity Testing: a Review. *Envir. Pollution* 87: 319-336.
- Linderman R.G.** 2000. Effects of mycorrhizas on plant tolerance to diseases. In: Kapulnik Y., Douds D.D. Jr (ed.) *Arbuscular mycorrhizas: physiology and function* Kluwer Academic Publishers, Dordrecht, The Netherlands, 345-365.
- LOLFA/LWA** 1985. Bewertung des ökoloigischen Zustands von Fließgewässern. Landesamt für Wasser und Abfall in Nordrhein - Westfalen, Düsseldorf.
- Lunte C. C., Luecke C.** 1990. Trophic interactions of *Leptodora* in Lake Mendota. *Limnology and Oceanography* 35 (5): 1091-1100.
- Mander U., Palang H.** 1996. Landscape evolution in Estonia. p: 111-122 In: *Landscape diversity: a chance for rural community to achieve a sustaina-*

- ble future. (L. Ryszkowski, G. Pearson & S. Balazy, eds.) Research Centre for Agricultural and Forest Environment PAS. Poznan, .
- Mander U., Palang H. & Jagomagi J.** 1995. Ecological networks in Estonia. Impact of landscape change. *Landschap* 3: 27-38
- Mankiewicz J., Tarczynska M., Walter Z., Zalewski M.** 2003. Natural Toxins from Cyanobacteria. *Act. Biol. Cracoviensia* 45/2: 9-20
- Mankiewicz J., Tarczynska M., Jurczak T., Wojtysiak-Staniaszczyk & Zalewski M.** 2003. Test with luminescent bacteria for the toxicity assessment of cyanobacterial bloom samples. *FEB* 12(8): 861-864.
- Marques, J.C., S.N. Nielsen, M. Pardal & S. Jorgensen** (in press). Impact of eutrophication and river management within a framework of ecosystem theories. *Ecological Modelling*
- Marsalek B., Blaha L.** 2000. Microbiotest for cyanobacterial toxins screening. p: 519-525 In: *New Microbiotest for Routine Toxicity Screening and Biomonitoring.* (G. Personne et al., eds.) Kluwer Academic / Plenum Publishers, New York.
- McMillan P. H.** 1998. An integrated habitat assessment system (IHAS v2) for the rapid biological assessment of rivers and streams. Research Project number ENV-P-I-98132. Council for Scientific and Industrial Research (CSIR), Water Resources Management Programme, South Africa.
- McQueen D. J., Post J. R. & Mills E. L.** 1986. Trophic relationships in freshwater pelagic ecosystems. *Canadian Journal Fisheries and Aquatic Sciences* 43: 1571-1581.
- Meriluoto J.** 1997. Chromatography of microcystins. *Analyt. Chim. Acta*, 352: 277-298.
- Meriluoto J., Eriksson J.** 1988. Rapid analysis of peptide toxins in cyanobacteri. *J. Chromatog.* 438,93-99.
- Meriluoto, J., Lawton, L., & Harada, K-I.** 2000. Isolation and detection of microcystins and nodularins, Cyanobacterial peptide hepatotoxins. p: 65-87 In: O. Holst (Ed.), *Bacterial Toxins: Methods and Protocols.* Totowa: Humana Press Inc.
- Meybeck M.** 2002. Riverine quality at the Anthropocene : Propositions for global space and time analysis, illustrated by the Seine River. *Aquatic Sciences*, 64: 376-393.
- Meybeck M.** 2003. Global analysis of river systems : from earth system controls to Anthropocene controls. *Phil. Trans. Royal Acad. London B*, 354: 1440.
- Mitsch W., Jorgensen S. E.** 2004. *Ecological Engineering and Ecosystem Restoraton.* John Wiley and Sons. Inc. USA. 411 pgs.
- Mitsch W. J., Jorgensen S. E. Hoboken, N.J.** 2004. *Ecological Engineering and Ecosystem Restoration:* Wiley, c2004. QH541.15.R45 M58 2004.
- Miller R.M., Jastrow J.D.** 2000. Mycorrhizal fungi influence soil structure. In: Y. Kapulnik, D.D. Doouds (ed.) *Arbuscular Mycorrhizas: Physiology and Function,* Kluwer Academic Publishers, Netherlands, 3-18.
- Morais P, Chicharo, M.A. & Barbosa, A..** 2003 *Phytoplankton Dynamics in a coastal saline lake* *Acta Oecologica* 24:S87-S96
- Nakamura Y. & F. Kerciku** 2000 Effects of filter-feeding bivalves on the distribution of water quality and nutrient cycling in a eutrophic coastal lagoon. *Journal of Marine Systems* 26 209-221
- Nalecz-Jawecki, G., Taczynska, M. & Sawicki, J.** 2002. Evaluation of the toxicity of cyanobacterial blooms in drinking water reservoirs with micro-biotest. *FEB* 11, 347 - 351.
- Naiman, R.J., Decamps, H., Fournier, F.** (eds.), 1989. *Role of land / inland water ecotones in landscape management and restoration, proposals for collaborative research.* UNESCO, Vendome, France.
- Natures Services. Societal Depenence on Natural Ecosystems.** 1997. ed. G.C. Daily. Island Press. USA. 392 pgs.
- Negri M. C., Hinchman R. R., & Gatliff E. G.** 1996. Phytoremediation: using green plants to clean up contaminated soil, groundwater, and wastewater. p: In, *Proceedings, International Topical Meeting on Nuclear and Hazardous Waste Management,* Spectrum 96. Seattle, WA, August 1996. American Nuclear Society
- Newcomb D., Van Abs D. J.** 2000, *Riparian Methodology. Methodology for defining and assesing riparian areas in the Raritan river basin.* New Jersey Water Supply Authority.
- Newson M.D., Harper D.M., Padmore C.L., Kemp J.L. and Vogel B.** 1998. A cost-effective approach for linking habitats, flow types and species requirements. *Aquatic Conservation: Marine and Freshwater Ecosystems* 8: 431-446.

- Nicholson, B.C. & Burch, M.D.** 2001. Evaluation of analytical methods for detection and quantification of cyanotoxins in relation to Australian drinking water guidelines. In: A report prepared for the National Health and Research Council of Australia, the Water Services Association of Australia, and the Cooperative Research Centre for Water Quality and Treatment. Australia.
- NRA Severn** - Trent Region F.R.C.N. Guidelines.
- Odum E. P. 1971. *Fundamentals of Ecology*. Saunders, Philadelphia. 574 pp.
- Oliveira R..S., Dodd J.C., Castro P.M.L.** 2001. The mycorrhizal status of *Phragmites australis* in several polluted soils and sediments of an industrialised region of Northern Portugal. *Mycorrhiza* 10:241-247
- Oliver R.L., Granf G.G.** 2000. Freshwater blooms. [in] Whitton B.A., Potts M. (eds.) *The ecology of cyanobacteria*. Kluwer Academic Publishers: 149-194.
- ONORM M 6232.** 1995. Richtlinien für die ökologische Untersuchung und Bewertung von Fließgewässern. Österreichisches Normungsinstitut, Wien.
- Onyewuenyi, N. & Hawkins, P.** 1996. Separation of toxic peptides (microcystins) in capillary electrophoresis, with the aid of organic mobile phase modifiers. *J. Chromatogr. A* 749: 271-278.
- Owens P.N., D.E. Walling.** 2002. The phosphorus content of fluvial sediment in rural and industrialised river basins. *Water Research* 36: 685-701.
- Ozimek T.** 1991. Macrophytes as biological filters in sewage purification processes. *Wiadomości Ekologiczne* 37:271-281.
- Ozimek T., Donk E., Gulati R.,** 1993 Growth and nutrient uptake by two species of *Elodea* in experimental conditions and their role in nutrient accumulation in a macrophyte - dominated lake. *Hydrobiologie* 251: 13-18
- Ozimek T., Renman G.,** 1995. Use of macrophytes in unconventional sewage treatment plant. Wykorzystanie makrofitów w niekonwencjonalnych oczyszczalniach ścieków. *Wiad. Ekol.* 41: 239-254. (in polish)
- Paasche, E.,** 1980. Silicon content of five marine plankton diatom species measured with a rapid filter method, *Limnol. Oceanogr.*, 25 (3), 474-480.
- Parson M., Thomas M. & Norris R.** 2002 Australian River Assessment System: Review of Physical River Assessment Methods - A Biological Perspective. Monitoring River Health Initiative Technical Report 21, Environment Australia.
- Pekarova, P., J. Pekar.** 1996. The impact of land use on stream water quality in Slovakia. *J. Hydrol.*, 180: 333-350.
- Penczak T. Zalewski M.** 1973. Distribution of fish numbers and biomass in barbel region of the river and the adjoining old river-beds. *Ekologia Polska* 22 1 107-119.
- Perillo, G.M.E.** 1995. Geomorphology and Sedimentology of Estuaries. Definitions and Geomorphologic Classifications of Estuaries, Development in Sedimentology 53. Pritchard, D. W. 1967. What is an estuary: physical viewpoint. p. 3-5 in: G. H. Lauf (ed.) *Estuaries*, A.A.A.S. Publ. No. 83, Washington, D.C.
- Persoone G., J. Gillett,** 1990. "Toxicological versus ecotoxicological testing". [w]: ed. P. Bourdeau "Short-term toxicity tests for non-genotoxic effects". SCOPE. wyd. John Wiley & Sons. Ltd.
- Peterjohn W. T., Corella D. L.** 1984. Nutrient dynamics in an agricultural watershed: observation on the role of a riparian forest. *Ecology* 65:1466-1475.
- Petersen R. C., Petersen L. B.-M. & Lacoursiere J.** 1992. A building-block model for stream restoration. p: 293-309. In: *River Conservation and Management* (P. J. Boon, P. Calow & G.E. Petts, eds.) John Wiley & Sons Ltd., Chichester, New York, Toronto, Singapore.
- Phillips N., Bennett J. & Moulton D.** 2001 Principles and tools for the protection of rivers, Queensland Environmental Protection Agency report for LWA.
- Phillips J.D.** 1999. *Earth surface systems*. Blackwell, Oxford.
- Poon, G.K., Griggs, L.J., Edwards, C., Beattie, K.A., Codd, G.A.** 1993. Liquid chromatography-electrospray ionisation-mass spectrometry of cyanobacterial toxins. *J. Chromatogr.* 628: 215-233.
- Postel S.,** 1992. *Last Oasis - Facing Water Scarcity*. W.W. Norton & Company, New York
- Pritchard D. W.** 1967. What is an estuary: physical viewpoint. p. 3-5 in: G. H. Lauf (ed.) *Estuaries*, A.A.A.S. Publ. No. 83, Washington, D.C.
- Rapala, J., Erkomaa, K., Kukkonen, J., Sivonen K. & Lahti, K.** 2002. Detection of microcystins with protein phosphatase inhibition assay, high-perfor-



- mance liquid chromatography-UV detection and enzyme-linked immunosorbent assay, Comparison of methods. *Anal. Chim. Acta* 466: 213-231.
- Raskin I., Ensley B. (eds.)**. 2000. Phytoremediation of Toxic Metals. Wiley Interscience N.Y.
- Raven P.J., Fox P., Everard M., Holmes N. T. H. & Dawson F.H.** 1997. River habitat survey: a new system for classifying rivers according to their habitat quality. p: 215-234 In: *Freshwater Quality: Defining the Indefinable?* (P. J. Boon, D. L. Howell, eds) The Stationery Office, Edinburgh.
- Read, D.J., Lewis, D.H., Fitter, A.H., Alexander, I.J.** 1992. Mycorrhizas in ecosystems. Oxford: CAB International.
- Reddy K. R., DeBusk W. F.** 1987. Nutrient Storage Capabilities of Aquatic and Wetland Plants. p: 337-357. In: *Aquatic Plants for Waste Water Treatment and Resource Recovery*. (K. R. Reddy, W. H. Smith eds.) Magnolia Publishing, Orlando FL
- Redfield, A. C., B. H. Ketchum, and F. A. Richards.** 1963. The influence of organisms on the composition of seawater. pp. 26-77. In M. N. Hill (ed). *The Sea*. Vol. 2. *The Composition of Seawater*. Wiley, New York.
- Reisinger H. J., Mountain S. A., Andreotti G., Diluise G., Porta A., Hullman A. S., Ovens V., Arlotti D. & Godfrey J.** 1996. Bioremediation of a Major Inland Oil Spill Using a Comprehensive Integrated Approach. *Proceedings of Third International Symposium and Exhibition on Environmental Contamination in Central and Eastern Europe*. Warsaw.
- Ressom, R., San Soong, F., Fitzgerald, J., Turczynowicz, L., El Saadi, O., Roder, D., et al.** 1994. Health effects of toxic Cyanobacteria (Blue - Green Algae). p: 27-69. Australian Government Publishing Service, Canberra.
- Rice, K.C., O.P. Bricker.** 1995. Seasonal cycles of dissolved constituents in streamwater in two forested catchments in the mid-Atlantic region of the eastern USA. *J. Hydrol.*, 170. 137-158.
- Rocha, C., Galvao, H., & Barbosa, A.** (2002). Role of transient silicon limitation in the development of cyanobacteria blooms in the Guadiana estuary, south-western Iberia. *Mar. Ecol. Prog. Ser.*, 228, 35-45.
- Rodriguez-Iturbe I.** 2000. Ecohydrology: a hydrological perspective of climate-soil-vegetation dynamics. *Water Resources Research* 36: 3-9.
- Roelke, D.L.** 2000. Copepod food quality threshold as a mechanism influencing phytoplankton succession and accumulation of biomass, and secondary productivity: a modelling study with management implications. *Ecological Modelling*, 134: 245-274
- Romanowska-Duda, Z. & Tarczyńska, M.** 2002. The influence of Microcystin-LR and hepatotoxic cyanobacterial extract on water plant (*Spirodela oligorrhiza*). *Environ. Toxicol.* 17(3): 383-390.
- Root R.B.** 1967. The niche exploitation pattern of the blue-gray gnatcatcher. *Ecological Monographs* 37: 317 - 350.
- Roper W.L.** 1991. Preventing Lead Poisoning in Young Children. US Department of Health and Human Services. Public Health Service, Center for Disease Control.
- Rosgen D.L.** 1996. Applied river morphology. *Wetland Hydrology*. Colorado.
- Russell, M.A., D.E. Walling, R.A. Hodgkinson.** 2001. Suspended sediment sources in two small lowland agricultural catchments in the UK. *J. Hydrol.*, 252: 1-24.
- Rutherford I. D., Jerie K. & Marsh N.** 1999. A rehabilitation manual for Australian streams, vol. 1 & 2, Land and Water Resources Research and Development Corporation & CRC for Catchment Hydrology, Canberra.
- Ryszkowski L.** 1985. Impoverishment of soil fauna due to agriculture. *Intecol Bulletin* 12: 7-17.
- Ryszkowski L.** 1992. Energy and Material Flows Across Boundaries in Agricultural Landscapes. p: 270-284 In: *Landscape Boundaries: Consequences for Biotic Diversity and Ecological Flows* (J. Andrew Hansen Francesco di Castri eds). Springer-Verlag. 13
- Ryszkowski L.** 1994. The integrated development of the countryside in central and eastern European countries. *Nature and Environment* 70, Council of Europe Press. 39 pp.
- Ryszkowski L., Kedziora A.** 1996. Ecological guidelines for management of agricultural landscape. In: *Dynamics of an agricultural landscape*. p: 213-223 (L. Ryszkowski, N. French & A. Kedziora, eds.) PWRiL, Poznan,.
- Ryszkowski L., Bartoszewicz A. & Kedziora A.** 1997. The potential role of mid-field forests as

- buffer zones. p: 171-191 In: Buffer Zones: Their Processes and Potential in Water Protection (N. Haycock, T. Burt, K. Goulding & G. Pinay, eds.). Quest Environmental. Harpenden, Hertfordshire, UK.
- Salt D.E., Blaylock N., Kumar N., Dushenkov V., Ensley B.D., Chet I., Raskin I.** 1995. Phytoremediation: A novel strategy for the removal of toxic metals from the environment using plants. *Biotechnol* 13: 468-474.
- Sano, T., Nohara, K. Shirai, F. & Kaya, K.** 1992. A method for microdetection of total microcystin content in waterbloom of cyanobacteria (blue-green algae). *Int. J. Environ. Analyt. Chem.* 49:163-170.
- Sas-Nowosielska A., Kucharski R. & Korcz M.** 2001. Optimizing of land characterization for phytoextraction of heavy metals. *Obieg pierwiastkow w przyrodzie. Monografia t.1.* IOS Warszawa: 345-348.
- Scheffer M., Houser S. H., Meijer M.-L., Moss B. & Jeppesen E.** 1993 - Alternative equilibria in shallow lakes. *Trends in Ecology and Evolution* 8: 275-279.
- Schiemer F., Zalewski M., Thrope J.E., [eds]** 1995 *The Importance of Aquatic - Terrestrial Ecotones for Freshwater Fish Developments in Hydrobiology* Kluwer Academic Publishers
- Schiemer F.,** 1999. Limnological research in the Danube wetlands with emphasis on environmental management and restoration scenarios. *Stroy* In: *Groundwater ecology. A tool for management of water resources* (D. L. Danielopol, C. Griebler, J. Gibert, H.P. Nachtnebel & J. Notenboom, eds.). Lecture notes. Austrian Academy of Science - Institute of Limnology. Vienna - Mondsee.
- Schiemer F., Spindler T.** 1989. Endangered fish species of the Danube River in Austria. *Regulated Rivers. Research and Management* 4:397-407.
- Schiemer F., Zalewski M. & Thorpe J.. (eds.). 1995. *The Importance of Aquatic-Terrestrial Ecotones for Freshwater Fish . Developments in Hydrobiology* 105. Kluwer Academic Publishers,
- Schmutz S., Kaufmann M., Vogel B. & Jungwirth M. (eds.).** 2000b. *Methodische Grundlagen Und Beispiele Zur Bewertung Der Fischökologischen Funktionsfähigkeit Österreichischer Fliessgewässer.* Institut für Wasserversorgung, Gewässergüte und Fischereiwirtschaft Abteilung für Hydrobiologie, Fischereiwirtschaft und Aquakultur Universität für Bodenkultur, Wien, 211pp.
- Schmutz S., Kaufmann M., Vogel B., Jungwirth M. (eds.).** 2000b. *Methodische Grundlagen Und Beispiele Zur Bewertung Der Fischökologischen Funktionsfähigkeit Österreichischer Fliessgewässer.* Institut für Wasserversorgung, Gewässergüte und Fischereiwirtschaft Abteilung für Hydrobiologie, Fischereiwirtschaft und Aquakultur Universität für Bodenkultur Wien. 211pp.
- Schmutz S., Kaufmann M., Vogel B., Jungwirth M., & Muhar S.** 2000a. A multi-level concept for fish-based, river-type-specific assessment of ecological integrity. *Hydrobiologia* 422/423: 279-289.
- Schumm S. A.** 1977. *The Fluvial System.* John Wiley and Sons, New York.
- Seidel K.,** 1966. *Biologischer Seenschutz (W: Pflanzen als Wasserfilter) - Foederation Europaischer Gewässerschutz Symposium,* 76: 357-369.
- Shannon, C. & W. Weaver:** 1949. *Mathematical theory of communication,* University of Illinois Press, Urbana.
- Shapiro J., Lamarra V., Lynch M.** 1975. *Biomani-pulation: an ecosystem approach to lake restoration.* p: 85-96 In: *Proceedings of a Symposium on Water Quality Management Through Biological Control* (P. L. Brezonik, J. L. Fox, eds.) University of Florida.
- Simpson J. C., Norris R. H.** 2000. Biological assessment of river quality: development of AusRivAS models and outputs.p: 125-142 In: *Assessing the biological quality of freshwaters.* (J. F. Wright, D. W Sutcliffe & M.T. Furse, eds.) RIVPACS and other techniques. *Freshwater Biological Association, Ambelside.*
- Smayda, T.,** 1990. Novel and nuisance phytoplankton blooms in the sea: Evidence for a global epidemic, in *Toxic Marine Phytoplankton,* edited by E. Graneli, B. Sundstrom, L. Edler, and D. M. Anderson, Elsevier, New York.
- Smith S.E., Read D.J.** 1997. *Mycorrhizal Symbiosis.* Academic Press, London. pp.605.
- Sommer, U.** 1986. Phytoplankton competition along a gradient of dilution. *Oecologica,* 68: 503-506.
- Sommer U., Stibor H.** 2002. Copepoda - Cladocera - Tunicata: The role of the three major mezo-zooplankton groups in pelagic food webs. *Ecological Research* 17: 161-174.

- Sommer U.** 1992. Phosphorus limited *Daphnia*: intraspecific facilitation instead of competition. *Limnology and Oceanography* 37: 966-973.
- Sommer U., Gliwicz Z. M., Lampert W. & Duncan A.** 1986. The PEG-model of seasonal succession of planktonic events in fresh waters. *Archiv fur Hydrobiologie* 106: 433-471.
- Sorokin Y. I.** 1999. *Aquatic microbial ecology*. Buxkhus Publishers, Leiden.
- Southwood T. R. E.** 1977. Habitat, the template for ecological strategies. *Journal Animal Ecology* 46: 337-365.
- Stalnaker C. B.** 1993. Fish habitat models in environmental assessments. p: 140-162 In: *Environmental Analysis. The NEPA-Experience*. (S.G. Hildebrand, J.B. Cannon, eds) CRC Press, Boca Raton. Fla.
- Stalnaker C. B., Lamb B. L., Henriksen J., Bovee K., & Bartholow J.** 1995. *The Instream Flow Incremental Methodology: A Primer for IFIM: Biological Report* 29, 45 pp.
- Steedman H. F.,** 1976. *Zooplankton fixation and preservation*. UNESCO Press, Paris, 350 pp.
- Strahler A.N.** 1964. Quantitative analysis of watershed geomorphology. *American Geophysical Union Transactions* 38, 913-920.
- Suess M.J.** 1982. *Examination of water for pollution control. A reference handbook*. Vol. 3. WHO. Copenhagen. Pergamon Press, 251-255.
- Sutton, J.C., Sheppard, B.R.** 1976. Aggregation of sand-dune soil by endomycorrhizal fungi. *Can. J. Bot.* 54: 326-333.
- Swanson F.J., Gregory S.V., Sedell J.R., Campbell A.G.** 1982. Land-water interactions: the riparian zone. P.267-291 In R.L. Edmonds (ed.), *Analysis of coniferous forest ecosystems in the western United States*. Hutchinson Ross, Stroudsburg, Pennsylvania, USA.
- Swenson S. M., C.P. Rickard, K. E. Freemark, P. Mac Quarrie** 1991. Testing for Pesticide Toxicity to Aquatic Plants: recommendations for Test Species. *Plants for toxicity Assessment: second Volume*, ASTM STP 1115, J. W. Gorsuch, W. R. Lower, W. Wang and M. Lewis, Eds., American Society for testing and materials, Philadelphia, 1991, 77-97.
- Swoboda, U.K., Dow, C.S., Chaivimol, J., Smith, N. & Pound, B.P.** 1994. Alternatives to the Mouse Bioassay for Cyanobacterial Toxicity Assessment. p: 106-110 In: G.A. Codd et al. (Eds.), *Detection methods for cyanobacterial toxins*. The Royal Society of Chemistry, Cambridge, UK.
- Szczepanski A.,** 1977. Limiting factors and productivity of macrophytes. *Folia geobot. Phytotax.*, 12 : 1-7.
- Szpakowska B., Zyczynska-Baloniak I.** 1994. The role of biogeochemical barriers In water migration of humin substances. *Polish Journal Environmental Studies* 3 (2): 35-41.
- Takeda S. & Kurihara Y.** 1994. Preliminary study of management of red tide water by the filter feeder *Mytilus edulis galloprovincialis*\*1, *Marine Pollution Bulletin*, 28(11): 662-667
- Tarczynska, M., Romanowska-Duda, Z. & Zalewski, M.** 1997. *Spirodela ologorrhiza* culture as bio-test of cyanobacterial blooms toxicity. *Acta Physiologiae Plantarum* 19(2): 242-243.
- Tarczynska, M.** 1998. Causes of toxic cyanobacterial blooms appearance in the Sulejow Reservoir and theirs effect of representatives of freshwater ecosystems. PhD. University of Lodz (in Polish)
- Tarczynska M., Nalecz-Jawecki G., Romanowska-Duda Z., Sawicki J., Beattie K., Codd G. & Zalewski M.** 2001. Test for the Toxicity Assessment of Cyanobacterial Bloom Samples. *Environmental Toxicology* 16: 383-390.
- Tarczynska M., Romanowska-Duda Z., Jurczak T., Zalewski M.** 2001. Toxic cyanobacterial blooms in drinking water reservoir - causes, consequences and management strategy. *Wat. Science and Technology. Water Supply* 1: 237-246.
- Tarczynska M., Nalecz-Jawecki G., Brzychcy M., Zalewski M. & Sawicki J.** 2000. The toxicity of cyanobacterial blooms as determined by micro-biotests and mouse assay. p: 527-532 In: *New Microbiotest for Routine Toxicity Screening and Bio-monitoring*. (G. Personne et al., eds.), Kluwer Academic / Plenum Publishers, New York.
- Tessier A., Campbell P G C & Bisson imie** 1979: Sequential extraction procedure for the speciation of particulate trace metals. *Anal. Chem.* 51: 844-850.
- Thienemann A. (ed.)** 1925. *Die Binnengewasser* 1. *Die Binnengewasser Mitteleuropas*. Stuttgart: Schweitzerbart'sche Verlagsbuchhandlung.
- Thornton J. A. (ed.)** 1982. *Lake Mcllwaine: the eutrophication and recovery of a tropical African man-made lake*. *Monographiae Biologicae* vol. 49, Junk, The Hague. 251 pp.

- Tiedje J. M.** 1982. Denitrification. p: 1011-1026 In Method of soil analysis (A. L. Page, R.H. Miller & D. R. Keeney, eds.) Pt. 2, Agronomy Monograph 9, American Society of Agronomy, Madison, Wis.
- Timchenko V., Oksiyuk O., Gore J.**, 2000. A model of ecosystem state and water quality management in the Dnieper Delta. Special Issue. Ecological Engineering 16: 119-126.
- Todd N. J. & Todd J.** 1993. From Eco-cities to Living Machines. Principles of Ecological Design. North Atlantic Books. USA. 197 pgs.
- Torokné, A. K.** 2000. The potential of the Thamotoxkit microbiotest for routine detection of cyanobacterial toxins. p: 533-539 In: G. Personne et al. (eds.). New Microbiotest for Routine Toxicity Screening and Biomonitoring. Kluwer Academic / Plenum Publishers, New York.
- Townsend C. R., Hildrew A. G.** 1994. Species traits in relation to a habitat template for river systems. Freshwater Biology 31: 265-275.
- Törökne, A. K.** 1999 A new culture-free microbiotest for routine detection of cyanobacterial toxins. Environmental Toxicology Water Quality 1999, 14: 466 - 472.
- Trihey E.W., Stalnaker C. B.** 1985. Evolution and application of instream flow methodologies to small hydropower development: An overview of the issues. p:176-183 In: Proceedings of the symposium on small hydropower and fisheries. (F.W. Olson, R.G. White & R.H. Hamre, eds). The American Fisheries Society. Denver, Colorado.
- Turner, R. E. and N. N. Rabalais.** 1994. Coastal eutrophication near the Mississippi River delta. Nature 368: 619-621.
- Turner, R. E., and Rabalais N. N..** 1994. Changes in Mississippi River nutrient supply and offshore silicate-based phytoplankton community responses, p. 147-150. In K. R. Dyer and R. J. Orth [eds.], Changes in fluxes in estuaries: Implications from science to management. Olsen & Olsen Fredensborg.
- Twinch A. J., Grobler D. C.** 1986. Pre-impoundment as a eutrophication management option: a simulation study at Hartbeespoort Dam. Water S.A. 12: 19-26.
- US EPA.** 1989a. Remedial Investigation and Feasibility Study at the Tonolli Corporation Site. Nesquehoning, PA.
- US EPA.** 1989. Risk Assessment Guidance for Superfund. Vol.1. Human Health Evaluation Manual. Parts A, B and C. US EPA /540/1-89/002. Washington.
- U.S. EPA.** 1997. Recent Developments for In situ Treatment of Metal Contaminated Soils. 542-R-97-004
- Uhlman D.** 1975 Hydrobiologie. Fischer, Studgart.
- UNEP.** 2000. Lakes and Reservoirs Similarities, Differences and Importance. Newsletter and Technical Publications Volume 1
- UNEP.** 2003. Phytotechnologies. A Technical Approach in Environmental Management. UNEP, Division of Technology, Industry and Economics. Freshwater Management Series No.7
- UNEP/Wetlands International.** 1997. Wetlands and Integrated River Basin Management: experiences in asia and the Pacific. asia Pacif-Kuala Lumpur. Malaysia. 346 pgs.
- Van der Ryn S. & Cowan S.** 1996. Ecological design. Island press. 201 pgs.
- Vangronsveld J., Van Assche F. & Clijsters H.** 1995. Reclamation of a bare industrial area contaminated by non-ferrous metals: in situ metal immobilization and revegetation. Environmental Pollution 87: 51-57.
- Varadi L.** 2003. A review of extensive/semi-intensive integrated freshwater fish production systems in Central and Eastern Europe. p: 88 - 91 In: Beyond Monoculture. (T.,Chopin, H. Reinertsen eds.) EAS Special Publication 33.
- Varadi L., Bekefi E.** 2003. Economic analysis of combined intensive - extensive pond fish production systems. p: 348-349 In: Beyond Monoculture. (T.,Chopin, H. Reinertsen eds.) EAS Special Publication 33.
- Verhoeven J. T. A., Maltby E., & Schmitz M. B.** 1990. Nitrogen and phosphorus mineralization in tens and bogs. Journal of Ecology 78: 713-726.
- Vorosmary C. J., Fekete B., Meybeck M. & Lambers R. B.** 2000. The global systems of rivers : its role in organizing continental landmass and defining land-to-ocean linkages. Global Biogeochemical Cycles, 14: 599-621. 100-
- Vorosmary C.J., Sahagian D.** 2000. Antropogenic disturbance of the terrestrial water cycle. Bioscience 50: 753-765.
- Vymazal J., Brix H., Cooper P.F., Green M.B. and Habrel R.** 1998. Constructed wetlands for waste water treatment in Europe. Backhuys Publisher, Leiden, 366 pp.

- Waggoner P. E.** 1990. Climate Change and U.S. Water Resources. John Wiley & Sons, New York
- Wagner I., Zalewski M.** 2000. Effect of hydrological patterns of tributaries on biotic processes in lowland reservoir - consequences for restoration. *Ecological Engineering*, Vol.16, 79-90.
- Wagner-Lotkowska I.** 2002. Influence of the selected climatic, hydrological and biological factors on eutrophication processes and symptoms in the Sulejów Reservoir, PhD Thesis [typescript] (in polish)
- Wang W.** 1989. Literatur review on duckweed toxicity testing. *Environ Research* 52:7-22.
- Ward J.V.** 1989. The four-dimensional nature of lotic ecosystems. *J. N. Am. Benthol. Soc.* 8: 2-8.
- Ward, C.J., Beattie, K.A., Lee, E.Y.C. & Codd, G.A.** 1997. Colorymetric protein phosphatase inhibition assay of laboratory strains and natural blooms of cyanobacteria: comparisons with high-performance liquid chromatographic analysis for microcystins. *FEMS Microbiol. Let.* 153: 465-473.
- Warwick RM, Clarke KR** (1995). New 'biodiversity' measures reveal a decrease in taxonomic distinctness with increasing stress. *Mar Ecol Prog Ser* 129, 301-305
- Water Framework Directive.** 2000. Directive of the European Parliament and of the Council 2000/60/EC Establishing a Framework for Community Action in the Field of Water Policy, 1997/0067(COD), C5-0347/2000, LEX 224, PE-CONS 3639/1/00, REV1.
- Water Quality Standarts Handbook** 1994., EPA-83-B-94-005a, secondo Edition (Maryland, USA)
- Weiß, J., Libert, H. P. & Braune, W.** 2000. Influence of Microcystin-RR on growth and photosynthetic capacity of the duckweed *Lemna minor* L. *J. Appl. Bot.* 74:100-105.
- Widdows, J.** 1985. Physiological Procedures. In: The Effects of Stress and Pollution on Marine Animals. B.L. Bayne et al. (Eds.). Toronto: Praeger Press. pp. 161-178.
- Willby N.J., Abernethy V.J., Demars B.O.L.** 2000. Attribute-based classification of European hydrophyte and its relationship to habitat utilization. *Freshwater Biology* 43: 43-74.
- Wilcock F.A. & Carter R.W.G.** 1977. An Environmental Approach to the Restoration of Badly Eroded Sand Dunes. *Biological conservation*. Vol.77: 279-291
- Wojtal A., Frankiewicz P. & Zalewski M.** 1999. The role of the invertebrate predator *Leptodora kindtii* in the trophic cascade of a lowland reservoir. *Hydrobiologia* 416: 215-223.
- Wolanski E., Boorman L. A., Chicharo L., Langlois-Saliou E., Lara R., Plater A. J., Uncles R. J. & Zalewski M.** 2004. (in press). Ecohydrology as a new tool for sustainable management of estuaries and coastal waters. *Wetlands Ecology and Management*.
- Woodhouse W.W.Jr.** 1978. Dune Building and Stabilization With vegetation. U.S. Army Corp of engineers. Vol.3: 9-104.
- Wootton R.** 1990 - Ecology of Teleost Fishes. London New York. Chapman and Hall. 404 pp.
- World Health Organization,** 1971. International Standards for Drinking-water, 3rd ed., Geneva,
- World Health Organization.** 1998. Guidelines for drinking water quality, 2nd ed., Addendum to Vol. 2, Health criteria and other supporting information. Geneva.
- Wright J.F., Furse M. T. & Armitage P. D.** 1993. RIVPACS - a technique for evaluating the biological quality of rivers in the U.K. *Water Research* 3: 15-25.
- Yoshida, T., Makita, Y., Nagata, S., Tsutsumi, T., Yoshida, F., Sekijiima, M.** 1997. Acute oral toxicity of microcystin-LR, a cyanobacterial hepatotoxin, in mice. *Natural Toxins* 5: 91-95.
- Yu S. Z.** 1995. Primary prevention of hepatocellular carcinoma. *Journal Gastroenterology and Hepatology* 10: 674-682.
- Zalewski M.** 1983. The influence of fish community structure on the efficiency of electrofishing. *Fish Management* 14(4):177-186.
- Zalewski M.,** 2000. Ecohydrology-the scientific background to use ecosystem properties as management tools toward sustainability of water resources. Guest Editorial *Ecological Engineering* 16:1-8.
- Zalewski M. (ed.)** 2002. Guidelines for the Integrated Management of the Watershed. Phytotechnology and Ecohydrology. UNEP, Division of Technology, Industry and Economics. *Freshwater Management Series No.5.*, 188 pp.
- Zalewski M., Cowx I.G.** 1990. Factors Affecting the Efficiency of Electric Fishing. Chapter 4, pp. 89-111, in: I.G. Cowx and P. Iamarque (eds) *Fishing with Electricity. Applications in Freshwater Fisheries Management*. Fishing News Books. 248 pp.

- Zalewski, M., Brewinka-Zaras, B., Frankiewicz, P. & Kalinowski, S.**, 1990. The potential for bio-manipulation using fry communities in low land reservoirs: concordance between water quality and optimal recruitment. *Hydrobiologica* 200/201: 549-556.
- Zalewski M., Naiman R. J.** 1985. The regulation of riverine fish communities by a continuum of abiotic-biotic factors. P: 3-9 in *Habitat modification and freshwater fisheries*. (J. S. Alabaster, ed.) FAO UN, Butterworths, London.
- Zalewski M., Brewinska - Zaras B., Frankiewicz P. & Kalinowski S.** 1990. The potential for bio-manipulation using fry communities in a lowland reservoir: between water quality and optimal recruitment. *Hydrobiology* 200/201: 549-556
- Zalewski M., Puchalski W., Frankiewicz P. & Bis B.** 1994. Riparian ecotones and fish communities in rivers - intermediate complexity hypothesis. p: 152-160 In: *Rehabilitation of Freshwater Fisheries*. (I.G. Cowx, ed.) Fishing News Books.
- Zalewski M., Janauer G. S. & Jolankai G. (eds.)**. 1997. *Ecohydrology - A new Paradigm for the Sustainable Use of Aquatic Resources*. International Hydrological Programme UNESCO. Technical Document on Hydrology No 7. Paris, 58 pp.
- Zalewski M., Tarczynska M., Wagner-Lotkowska I.** 2001. Ecohydrological approach for elimination of toxic algal blooms in lowland reservoir. *Verh. Internat. Verein. Limnol.* 27 1-8
- Zalewski M., Bis B., Frankiewicz P., Lapinska M. & Puchalski W.** 2001. Riparian ecotone as a key factor for stream restoration. *Ecohydrology & Hydrobiology* 1 (1-2): 245-251.
- Zalewski M., Lapinska M. & Bayley P. B.** 2003. Fish Relationships with wood in large rivers. p: 195-211. In: *Ecology and Management of Wood in World Rivers* (S. Gregory ed.) American Fisheries Society. Bethesda, Maryland.
- Zalewski M., Robarts R.** 2003. Ecohydrology a new Paradigm for Integrated Water Resources Management. *SIL News* 40:1-5
- Zalewski M., Wagner-Lotkowska I., Tarczynska M.** 2000. Ecological approaches to the elimination of toxic algal blooms in a lowland reservoir. *Limnology* 27 3176-3183.
- Zdanowicz A.** 2001. Influence of riparian ecotone zones on the nutrients concentration in groundwater. Falenty IMUZ, PhD thesis. (in Polish)
- Zdanowicz A.** 2004. Analizis of non-point sources pollution movement conditions in the Grabia river catchment. *Woda-Srodowisko-Obszary Wiejskie* in press. (in Polish)
- Zielinska K.**, 1997. Analizis of phosphorous content In different willow species from the shore of Sulejów Reservoir. Msc. Thesis. Analiza zawartosci fosforu w różnych gatunkach wierzb rosnacych nad Zalewem Sulejowskim. Praca magisterska, Katedra Ekologii Stosowanej Uniwersytetu Lodzkiego, Lodz, [typescript] (In polish)
- Zhou, L., Yu, D., Yu, H. et al.** 2000. Drinking water types, microcystins and colorectal cancer. *Zhonghua Yu Fang Yi Xue Za Zhi* 34(4): 224-226.

**INTERNET RESOURCES**

<http://www.unep.or.jp/ietc/Publications/Freshwater/FMS1/index.asp>  
<http://www.unep.or.jp/ietc/Publications/Freshwater/FMS2/index.asp>  
<http://www.unep.or.jp/ietc/Publications/Freshwater/FMS5/index.asp>  
<http://www.unep.or.jp/ietc/Publications/Freshwater/FMS7/index.asp>  
[http://www.unep.or.jp/ietc/Publications/Freshwater/SB\\_summary/index.asp](http://www.unep.or.jp/ietc/Publications/Freshwater/SB_summary/index.asp)  
<http://www.unep.or.jp/ietc/Publications/index.asp>  
<http://www.unep.or.jp/ietc/Publications/index.asp>  
<http://www.unep.or.jp/ietc/Publications/Integrative/EnTA/AEET/index.asp>  
[http://www.unep.or.jp/ietc/Publications/Short\\_Series/LakeReservoirs-4/index.asp](http://www.unep.or.jp/ietc/Publications/Short_Series/LakeReservoirs-4/index.asp)  
[http://www.unep.or.jp/ietc/Publications/Short\\_Series/LakeReservoirs-3/index.asp](http://www.unep.or.jp/ietc/Publications/Short_Series/LakeReservoirs-3/index.asp)  
[http://www.unep.or.jp/ietc/Publications/Short\\_Series/LakeReservoirs-2/index.asp](http://www.unep.or.jp/ietc/Publications/Short_Series/LakeReservoirs-2/index.asp)  
[http://www.unep.or.jp/ietc/Publications/TechPublications/TechPub-15/main\\_index.asp](http://www.unep.or.jp/ietc/Publications/TechPublications/TechPub-15/main_index.asp)  
<http://www.unep.or.jp/ietc/Publications/TechPublications/TechPub-17/index.asp>  
<http://www.unep.or.jp/ietc/Publications/TechPublications/TechPub-12/index.asp>  
<http://www.unep.or.jp/ietc/Publications/techpublications/TechPub-11/index.asp>  
<http://www.unep.or.jp/ietc/Publications/techpublications/TechPub-8b/index.asp>  
<http://www.unep.or.jp/ietc/Publications/techpublications/TechPub-7/index.asp>  
<http://www.unep.or.jp/ietc/Publications/techpublications/TechPub-5/index.asp>

## ■ CONTRIBUTING AUTHORS

Maciej Zalewski  
International Centre of Ecology,  
Polish Academy of Sciences  
Warsaw, Dziekanow Lesny 1 Konopnickiej Str.,  
05-092 Lomianki, Poland

Iwona Wagner-Lotkowska  
Centre for Ecohydrological Studies,  
University of Lodz,  
12/16 Banacha Str.,  
90-237 Lodz, Poland

Richard D. Robarts  
GEMS/Water Programme  
c/o National Water Research Institute  
11 Innovation Blvd.  
Saskatoon, SK, CANADA S7N 3H5

Agnieszka Bednarek,  
Piotr Frankiewicz,  
Tomasz Jurczak,  
Zbigniew Kaczkowski,  
Edyta Kiedrzyńska,  
Małgorzata Lapinska,  
Małgorzata Tarczyńska,  
Adrianna Trojanowska,  
Adrianna Wojtal,  
Centre for Ecohydrological Studies,  
University of Lodz,  
12/16 Banacha Str., 90-237 Lodz, Poland

Jan Bocian,  
Katarzyna Izydorczyk,  
Kinga Krauze,  
Joanna Mankiewicz,  
Beata Sumorok,  
International Centre of Ecology,  
Polish Academy of Sciences  
Warsaw, Dziekanow Lesny, 1 Konopnickiej Str.,  
05-092 Lomianki, Poland

Alberto T. Calcagno  
Argentine Institute of Water Resources;  
Faculty of Engineering University of  
Buenos Aires  
Azcuena 1360 P7 „15” - C1115AAI  
Buenos Aires, Argentina

Alexandra Chicharo,  
Luis Chicharo,  
University of Algarve,  
CCMAR, Campus de Gambelas (FCMA),  
8000-810 Faro, Portugal

Sven E. Jorgensen  
Department of Analytical Chemistry  
Universitetsparken 2  
DK-2100 Copenhagen  
Denmark

Zdzisław Kaczmarek,  
Institute of Geophysics,  
Polish Academy of Sciences  
64 Ks. Janusza Str., 01-452 Warsaw, Poland

Philippe Pypaert  
UNESCO -ROSTE  
Palazzo Zorzi, Castello 4930  
30122 Venice, Italy

Vicente Santiago-Fandino  
UNEP - IETC  
1091 Oroshimo-cho, Kusatsu-City,  
Shiga 525-0001, Japan

Rafał Kucharski,  
Aleksandra Sas-Nowosielska,  
Institute for Ecology of Industrial Areas,  
6 Kossutha Str., 40-933 Katowice, Poland

J. Michael Kuperberg,  
Florida State University  
226 Morgan Building, 2035 E. Paul Dirac  
Drive Tallahassee, FL 32310-3700

Artur Magnuszewski,  
Faculty of Geography and Regional Studies,  
University of Warsaw,  
30 Krakowskie Przedmieście Str.,  
00-927 Warsaw, Poland

Joanna Markowska  
Jacek Markowski  
Department of Agricultural Bases for Environ-  
mental Development,  
Faculty Computer Laboratory,  
Agricultural University of Wrocław  
24 Plac Grunwaldzki Str.  
50-363, Wrocław, Poland

Zdzisława Romanowska-Duda,  
Department of Plant Growth Regulation,  
University of Lodz,  
12/16 Banacha Str., 90-237 Lodz, Poland

Lech Ryszkowski,  
Andrzej Kedziora,  
Research Center for Agricultural  
and Forest Environments,  
Polish Academy of Sciences,  
Agricultural Academy of A. Cieszkowski  
19 Bukowska Str., 60-809 Poznań, Poland

Anna Zdanowicz,  
Institute for Land Reclamation  
and Grassland Farming,  
Falenty, 05-090 Raszyn, Poland



UNITED NATIONS EDUCATIONAL, SCIENTIFIC AND CULTURAL ORGANIZATION  
International Hydrological Programme

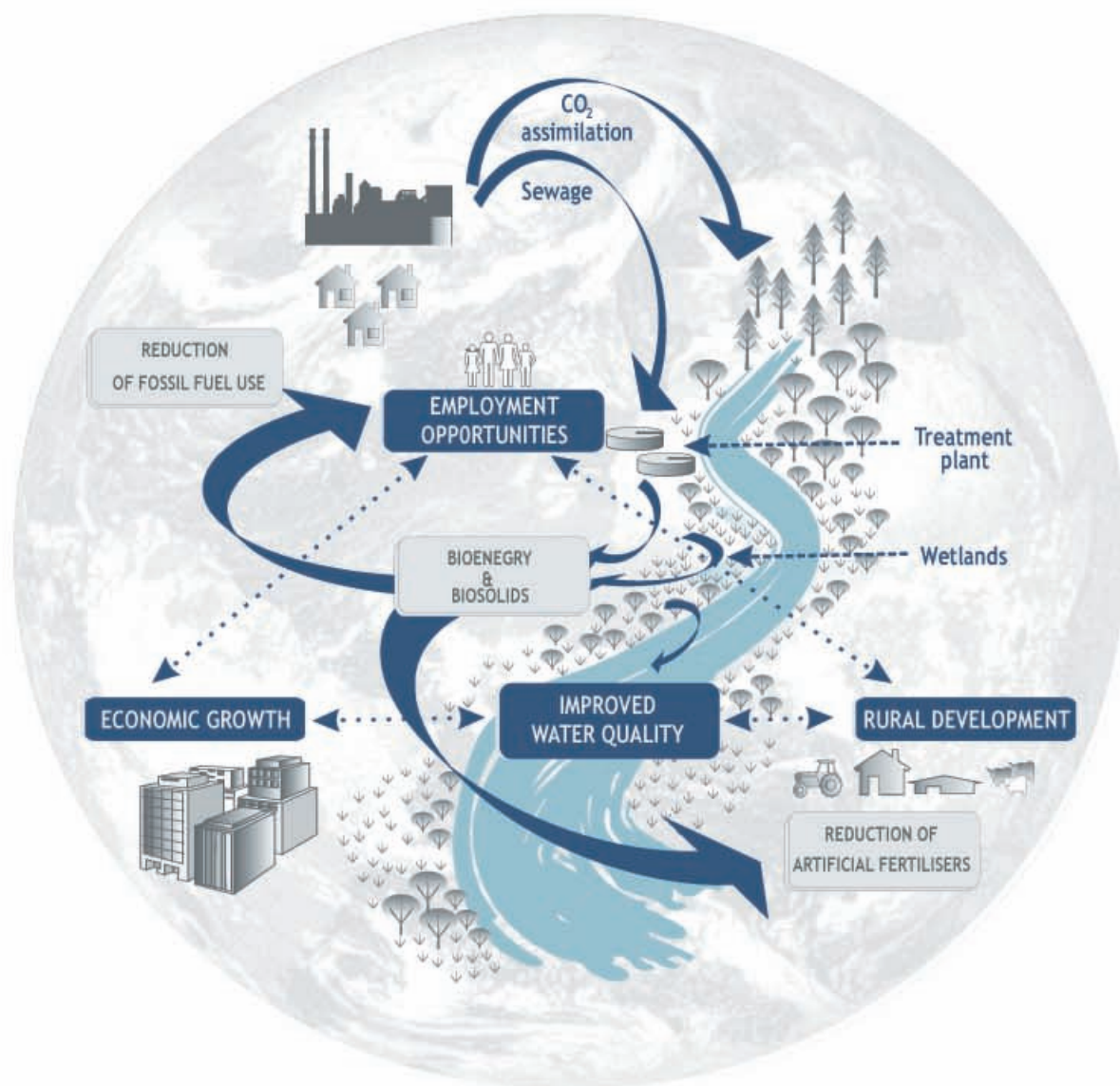

**UNESCO Regional Bureau for Science in Europe (ROSTE)**

Palazzo Zorzi, Castello 4930 - 30122 Venice Italy  
phone: +39 041 260 15 11, fax: +39 041 528 99 95

**UNESCO International Hydrological Programme**  
**Division of Water Sciences**

1, rue Miollis 75732 Paris Cedex 15, France  
phone: + 331 45 68 39 95, fax: + 331 45 68 58 11

The United Nations Environment Programme  
International Environmental Technology Centre  
International Centre for Ecology  
Polish Academy of Sciences  
Centre for Ecohydrological Studies  
University of Lodz