

World Heritage Scanned Nomination

File Name: 1063.pdf

UNESCO Region: EUROPE AND NORTH AMERICA

SITE NAME: Tokaj Wine Region Historic Cultural Landscape

DATE OF INSCRIPTION: 29th June 2002

STATE PARTY: HUNGARY

CRITERIA: C (iii)(iv)

DECISION OF THE WORLD HERITAGE COMMITTEE:

Excerpt from the Report of the 26th Session of the World Heritage Committee

Criterion (iii): The Tokaji wine region represents a distinct viticultural tradition that has existed for at least a thousand years and which has survived intact up to the present.

Criterion (v): The entire landscape of the Tokaji wine region, including both vineyards and long established settlements, vividly illustrates the specialized form of traditional land-use that it represents

BRIEF DESCRIPTIONS

The cultural landscape of Tokaj graphically demonstrates the long tradition of wine production in this region of low hills and river valleys. The intricate pattern of vineyards, farms, villages and small towns, with their historic networks of deep wine cellars, illustrates every facet of the production of the famous Tokaj wines, the quality and management of which have been strictly regulated for nearly three centuries.

1.b State, Province or Region: Borsod-Abaúj-Zemplén County

1.d Exact location: N48 09 E21 21

REPUBLIC OF HUNGARY

THE WORLD HERITAGE

Documentation

for the nomination of the

**CULTURAL LANDSCAPE OF
TOKAJI WINE REGION**

REPUBLIC OF HUNGARY

Present study is based on various contributions

Compiled by

VÁTI KHT – Budapest

commissioned by the
Hungarian Ministry of Environment Protection
Authority for Nature Conservation

Budapest 2000

Contents

	Page
I. Identification of the natural/cultural property	1
a. Country	1
b. Province	1
c. Name of Property	1
d. Exact location on map and indication of geographical co-ordinates	1
e. Maps and plans	2
f. Area proposed for inscription	3
II. Justification for inscription	4
a. Statement of the significance of the cultural/natural property	4
b. Comparative analysis	7
c. Integrity/authenticity	11
d. Criteria under which inscription is proposed	16
III. Description	20
a. Description of property	20
b. History and development	31
c. Form and date of most recent records of property	36
d. Present state of conservation	38
e. Policies and programmes related to the presentation and promotion of the property	40
IV. Management	41
a. Ownership	41
b. Legal status	41
c. Protective measures and means of implementing them	43
d. Agencies with management authority	45
e. Level at which management is exercised (on property, regionally) and name and address of contact person	45
f. Agreed plans related to property	46
g. Sources and levels of finance	48
h. Sources of expertise and training in conservation and management techniques	48
i. Visitor facilities and statistics	50
j. Property management plan and statement of objectives	51
k. Staffing levels (professional, technical, maintenance)	51

V.	Factors affecting the property	52
a.	Development pressures	52
b.	Environmental pressures	52
c.	Natural disasters and preparedness	52
d.	Visitor/tourism pressures	52
e.	Number of inhabitants within property, buffer zone	53
VI.	Monitoring	54
a.	Key indicators for measuring state of conservation	54
b.	Administrative arrangements for monitoring property	54
c.	Results of previous reporting exercises	54
VII.	Documentation	55
a.	Illustrations	55
b.	Copies of management plans and extracts of other relevant plans	55
c.	Bibliography	55
d.	Addresses where inventory, records and archives are held	58
	Annex	



I. Identification of the natural / cultural property

a) Republic of Hungary

b) Region: Borsod-Abaúj-Zemplén County

c) Name of property: Tokaji Wine Region Cultural Landscape

d) Exact location on map and indication of geographical co-ordinates

The total area of the proposed area and the buffer zone is identical with the area of the Tokaji Wine Region, as is set in the Act No. CXXI of 1997.

The area proposed for inscription is the part of the administrative areas of the following nine settlements, which includes the most significant habitats of the Tokaji Wine Region: Tokaj, Bodrogkeresztúr, Bodrogkisfalud, Mád, Mezőzombor, Rátka, Szegi, Tarcál, Tállya, and the Ungvári Wine-Cellar in Sátoraljaújhely, as well as the princely Rákóczi Wine-Cellar situated at Sárospatak.

The Core Area is a natural unite of the Wine Region's. The southern and south-western boundary are the railway and the secondary road N° 3713 running at the foot of the mountain, the northern and north-eastern boundary coincide with the administrative boundaries of relevant communities, as well as the main road N° 37, the eastern boundary is the administrative boundary. If the boundary runs in built area, the nomination extends to the both sides of the relevant streets. The registered mines within the boundaries of the Core Area having licences according to the Act No.XLVIII of 1993 on Mines are excepted from the World Heritage area.

The buffer zone consists of the administrative areas of the following settlements except those areas which are within the Core Area: Abaújszántó, Bekecs,

Bodrogkeresztúr, Bodrogkisfalud, Bodrogolaszi, Erdőbénye, Erdőhorváti, Golop, Hercegkút, Legyesbénye, Makkoshotyka, Mád, Mezőzombor, Monok, Olaszliszka, Rátka, Sáradsadány, Sárospatak, Sátorajjájhely, Szegi, Szegilong, Szerencs, Tarcal, Tállya, Tokaj, Tolcsva and Vámosújfalú.

Location and geographical co-ordinates

(WGS-84 ELLIPSOIDI KR.)

Property: north 48° 6' 12" to 48° 16' 32"
east 21° 11' 31" to 21° 26' 34"

Property and buffer zone: north 48° 4' 11" to 48° 26' 30"
east 21° 4' 14" to 21° 42' 30"

e) Maps and plans (see Annex 1e)

1. map: Geographical situation	1:500.000
2. map: Topographical map of Core Area of the Property	1:75.000
3. map: Property: Core Area and Buffer zone	1:250.000
4. map: Land use	1:250.000
5. map: Nature and landscape protection	1:250.000
6. map: Cultural heritage	1:250.000
7. map: City Map of Sátorajjájhely, with the sign of the nominated Ungvári Cellar	1:15.000
8. map: Entrances of Ungvári Cellar Sátorajjájhely	1:1000
9. map: Plan of Ungvári Cellar Sátorajjájhely	1:1000
10. map: City Map of Sárospatak, with the sign of nominated Rákóczi Cellar	1:15.000
11. map: Plan of Rákóczi Cellar Sárospatak	1:750

f) Area proposed for inscription

Area:	132,555 km ²
Buffer zone:	748,797 km ²
Alltogether :	881,352 km ²

II. Justification for inscription

Summary

The first closed wine region of the world (1737)

World-famous wine region

Site of finding of the Miocene fossil vine (Vitis Tokajensis)

Habitat of primary vine (Vitis sylvestris)

1000 year old viticulture

Richness in geological heritage

Diversity of soils

Particular geographical situation

Favourable climate for Botrytis cinerea (in winyards)

Particular microclimate for Gladosporium cellare (in vine-cellars)

Sessile oak for barrels and casks

Meeting point of Roman and Caucasian viticulture traditions

Common settlement heritage of several nations and religions

Architectural heritage of multilevel social system

Underground paradise (historic wine cellars)

Harvest celebrations

Living testimony of thousand year relatedness of landscape

a) Statement of the significance of the natural / cultural property

The landscape of the Tokaji Wine Region - where this princely wine is produced for hundreds of years - is uniquely various and wonderful, showing up a special cultural value that has been elaborated and saved for us through the organic transforming work of people living in symbiosis with this area.

“For a country with one tongue and one manner is weak and shall fall. Therefore I command thee, my son, to aid aliens in good will and to hold them in high esteem, so that they shalt stay under thy wings rather than seek shelter elsewhere. “ These words of admonishment, written by the first King of Hungary, Saint Stephen (1000-1038) to his son, have resounded through the course of Hungarian history. In every era, peoples arrived and settled in the Carpathian Basin, bringing their own cultures with them. Kabars and Pechenegs, Jazygians and Cumanians, Saxons

and Swabians, Ruthenes and Poles, Serbs and Romanians, Armenians and Jewish. Who knows if there is a country in Europe which gave the peace of a new home to more peoples than Hungary? And who knows if there is a wine region that has profited from the skill of so many peoples as Tokaj has?

The settlement structure harmonises with the land in both its scale and internal structure within the proposed property and buffer zone. There is a rich and valuable stock of historic monuments which is an architectural documentation of the traditional agrarian land use and way of living. The area has been continuously populated since medieval times which is illustrated by overlapping material from different periods in the individual settlements, their ancient monuments and groups of buildings.

The grapes are grown in the vineyard, but the wine is made in the cellar. This is simple enough, but cellars and wineries may vary greatly in appearance, depending on the type of wine made in them. This is especially true for a wine region like Tokaj, shaped by centuries of tradition and long-established local wine specialties. The cellar, today superseded by the winery, has no doubt become the characteristic type of building across the Foothills of the Tokaji Wine Region. Here it has evolved through the centuries in very different ways than in other parts of Hungary.

The construction of most cellars in the Foothills of the Tokaji Wine Region took place between the mid-1500s to the late 17th century, during the period of the region's ascendancy.

Beyond the fact that cellars are typical architectural elements in the settlements of the wine region, the princely Rákóczi Wine-Cellar at Sárospatak and the Ungvári Wine-Cellar at Sátoraljaújhely deserve special attention.

The unique significance of Tokaji Wine Region was recognised very early. The emperor Charles VI (Charles III Hungarian king) declared the area almost the same as the property plus buffer zone to be a closed wine region, the first of this

kind in the world. The legal declaration of the borders of Tokaji Wine Region dates back nearly for four centuries.

Through the course of history, Tokaji has received accolades from such dignitaries of art as Beethoven, Rossini, Liszt, Schubert, and Goethe. Although the commitment of these geniuses to the wine of the Foothills of the Tokaji Wine Region turned out to be invaluable, the deposition of crowned “celebrities” have had even more clout.

Of special impact was the publicity stirred by Louis XIV, the Sun King, when he commanded that the festive royal table never be without Tokaji. He was also the author of the well-known aphorism “C’est le roi des vins et le vin des rois”, ”This is the king of wines, and the wine of kings.” The French monarchs’ love of Tokaji proved to be more than just a passing fad. Even Napoleon III, the last emperor, and Empress Eugenie, ordered 30-40 Gönc barrels of the wine for the Court every year.

The success of Tokaji is proverbial on Russian soil, where it listed Peter the Great and Empress Elizabeth Petrovna in the ranks of its most faithful customers. By contrast, few people know that Gustav III, King of Sweden, never had any other wine to drink. Louis XV and Frederick the Great tried to outdo one another in the excellence of the vintages they stocked when they treated Voltaire or Dumas to some Tokaji.

The papal devotion to the wine is an even older tradition. The first Pope to make a famous declaration was Pius IV, who was driven by a sip of a sweet wine from Tállya to exclaim at the Synod of Trident, “This wine is worthy of the Supreme Priest of God!” Pius X probably had a sweet spot for Tokaji as well. He went so far as to break Vatican mores when he ruled that even previously opened bottles were acceptable on the papal table-provided that the wine in question was Tokaji. The holy annunciation with the greatest impact of all, often quoted to this day, left the lips of Benedict XIV when he received a gift of Tokaji from Maria Theresa:

“Happy is the Queen who sent thee, happy is the soil that hath grown thee, and happy am I who drink thee.”

b) Comparative analysis

People around the world sought Tokaji, and many pursued its secret as well. The “cuttings transaction” perpetrated by Lazar Schwendi was not an isolated occurrence in the Foothills’ past. According to Romanian sources, the general was preceded, by an entire century, by Stefan Cel Mare, Prince of Moldova (1457-1504), who sought to promote viticulture in his country by importing canes from Tokaj, together with a vineyardist named Cotnari János. It was this master of vines who planted in Moldova the variety known in Hungarian as Kövérszőlő, the “Fat Grape,” and after whom both the grape and the wine region there came to be called Cotnar.

The third famous export of cuttings from Tokaj transpired in 1783, when empress Catherine II had defeated the last Tartar Khan and annexed the Crimean Peninsula to her Russian empire. The newly appointed governor of the province, Prince Patiomkin, promptly set about bringing an economic boom to the peninsula. As part of this scheme, he attempted to naturalize Tokaj’s viticulture in the Crimea. Pulling his diplomatic strings, he purchased 19,000 stocks and commissioned three Hungarian wine growers to plant them. This was how the Furmint and Hárslevelű grapes first appeared in the Crimea.

The uniqueness of the wine of Tokaj is a combined result of natural potential (climate, soil, the diverse location of the sites), the grape varieties grown, and the human factor, the culture of making wine. Thanks to the unmatched natural endowments of the land, the growers of Tokaj hail and welcome *Botrytis cinerea*, a mold considered to be the arch enemy in most other wine regions in the world. This fungus attacks the vineyards of the Foothills each year, although not always

to the same extent. Due to the favourable climatic conditions, the ensuing infection is not gray rot but a noble variety; the one responsible for botrytised, or Aszú, berries.

In Tokaj, the fungus concentrates the substances in the grapes to such an extent that the harvested must may contain over 850 grams of sugar (by comparison, the unfermented must of a good quality wine weighs in with 200 to 230 grams). This means that the must is so rich in sweetness-and also in acidity and aromas, that not all of the sugar in it can ferment into alcohol.

Of course, botrytis causes noble rot in other parts of the world as well, for instance along the Rhine, in Sauternes, Alsace, and the Loire but nowhere in the same quantity or quality as in Tokaj. Here botrytisation can be so perfect that it becomes feasible, indeed desirable, to pick the shriveled berries out of the bunch one by one. This makes for a special level of selection that is unrivaled anywhere else. To this day, the most precious grade of Tokaji, the Aszú is categorised based on the unique advantage of individually selected botrytised berries. In short, Tokaji Aszú is a naturally sweet white wine born from the inimitable coincidence of a number of factors. It is also the wine that made Tokaj world famous, and the one that drew the boundaries of the wine region in the most natural way possible.

The golden foothills are protected by verdant ridges to the north and the blue veins of rivers to the south.

This special situation facilitates haze lifting up from the rivers to create the special microclimate of the Tokaji Wine Region that *Botrytis cinerea* deserves.

Botrytis wines grown in northern locations, in particular German Beerenauslese and Trockenbeerenauslese wines, conquer the taster with their lively acids that are better retained under a cooler climate, and their intense sweetness. The botrytis and ice wines crafted in these regions are textbook examples of concentrated flavor.

Sauternes, the best-known botrytis wine of the southern type, owes its reputation to a completely different style. In Sauternes, it is rarely possible to put off the harvest indefinitely, waiting for colder days to set in. Fall near the Atlantic is more tempered and damp. The grapes ripen more fully, but lose their acids quickly, while in the presence of all that moisture, botrytis literally enshrouds and penetrates the berries. This natural potential has been realized in a splendid style by French winemakers. Their wines are composed not so much on the sugar/acid duality as on the juxtaposition between sweetness and the tartness resulting from intense botrytisation. The keywords in Sauternes are harmony and elegance, rather than concentration.

Tokaj is a uniquely located growing area. Under its climate, which is warmer than those of wine regions further north, the grapes ripen more fully, ideally, they are overripe, by the time botrytis sets in. This leads to a decisive difference between Tokaji and the Beerenauslese and Trockenbeerenauslese wines, not so much from the acid quantity as from the composition of that acidity. Also, the ripeness of the fruit and the drier continental climate together set Tokaji apart markedly from natural sweet wines of the southern type (such as Sauternes). The inside of well-ripened grapes with a higher sugar content is not the best habitat for botrytis to survive. When the autumn is long and dry, a requisite for optimum botrytisation, the noble mold penetrates the flesh of the fruit, where it transforms the aromas. However, it rarely injures the skins, and practically never forms a film on them. In good years, this scenario of botrytisation results in berries whose consistency is almost rubbery firm rather than runny, and which can thus be picked out of the bunch one by one. To put it differently, fruit selection in Tokaj can be carried to the extreme because of the way botrytisation takes place.

The picking out of botrytis berries, the highest possible order of fruit selection, had become an accepted and profitable practice in the Foothills of the Tokaji Wine

Region by the early 1600s. Such a system of selection was the ideal in every other wine region, but nowhere else was it put into practice as it was in Tokaj.

The famous Tokaji Aszú is, therefore, a wine crafted with the use of selected botrytis grapes.

Tokaj had a flourishing cooperage business until World War II. The wines called for fine barrels.

The best barrels and casks are made from sessile oak.

The forests of the Tokaj range supplied excellent timber to satisfy that demand. Zemplén oak has been a hallmark for quite some time, a brand recognized far and wide in the international world of wine. But what makes the Zemplén variety different from other members of the oak family?

Sessile oak (*Quercus Petraea*) is a large, long-living tree that grows slowly, sometimes to attain 200 years of age. It likes relative warmth and even water supply, but will tolerate smaller stretches of drought. It is a European species of oak, typical of the hills and mountains of the Atlantic and the Mediterranean. Like the pedunculate oak (*Quercus Robur*), it has a texture well-marked by growth rings visible to the naked eye. Its wood is medium-hard, resistant to wear, and positively durable due to its tannin content. Coopers like it because it is easy to split and work with. For them, the best varieties are the ones impermeable to liquids, namely the sessile oak and the pedunculate oak of the lowlands, although the former of the two is invariably preferred. As a source of staves, sessile oak growing in hills at an altitude of 400 to 700 meters has always been more sought-after.

The sessile oak groves of the Zemplén yield timber mostly of the medium-dry type. This excellent wood to use that commanded a hefty price before World War II.

Occasionally in Europe, one can come across a wine cask made in the first half of the century from Zemplén oak, but this particular wood has such close ties with Tokaji that are unique in the world of wine. While growers in the major wine regions of the Continent select the wood for their barrels from various and often very distant lands,

the famous wine of the Foothills of the Tokaji Wine Region has been inextricably linked with the renowned oak growing next door.

In wine regions of the world where great natural sweet wines are made, consumers need only to acquaint themselves with one or two wine categories, or four or five at the most. In contrast, Tokaj boasts no fewer than eight sweet wine categories unique to it, not counting wines labelled simply as late harvest, or two dry wines made from botrytised grapes.

At first glance, then, the available selection of Tokaji can seem to be bewildering. Adding to the confusion are the blurred differences between the various ways of processing the fruit and handling the wine after which the specialities have been named. These days, the wines of Tokaj are ranked in categories mostly, but not exclusively, based on their analytical parameters.

c) Integrity / Authenticity

Integrity

The presently known exclusively beautiful and culturally rich environment of Tokaji Wine Region has been created and preserved for us by humankind in association with, and response to, the natural environment.

The area boasts of very favourable natural and climate potentialities, which results in its unique suitability for vine-growing. Wines of this region have gained a European respect and rank very early.

The authenticity and integrity of the property proposed for inscription are based on geological, hydrological, geo-morphological, climatic, natural as well as regional and cultural historical relationships.

The Tokaj-Eperjes Range, including the Foothills of the Tokaji Wine Region, consists of low mountains or hills densely articulated by valleys and streams. Although its

surface took millions of years to take shape, and its original volcanic morphology has either disappeared or changed, the first glance suffices to ascertain the volcanic origins of the terrain. The volcanoes themselves were active nine 9-15 million years ago, creating the base rocks of Tokaj in such diversity that is unique in Europe. These volcanic sequences were later decomposed and altered by postvolcanic processes, adding further colour to the geology of the slopes.

The people of every age have found their own special treasures in Tokaj. In the New Stone Age, the obsidian of this land must have been much sought-after as excellent material for flint tools. A similar rarity of later times was the precious opal, an iridescent gem in three colours, which was collected from the northern side of the mountains. From medieval times on, gold and silver were produced at the mines of Telkibánya, which rose to national significance in the 15th century. The recovery of non-metallic resources started in the 1400s around Sárospatak, where quartzite was mined for the manufacture of millstones. Industrial development in the early 1900s brought a boom in the mining of other minerals such as kaolin, bentonite, rhyolite tuff, and andesite. Local resources have sustained the Porcelain Manufactory of Hollóháza since 1831. These days, there are few spas left utilizing the hot springs in the area, although in the early 20th century a large number of them offered their services to the guests.

The uniqueness of Tokaj as a wine region can be attributed to a large extent to the weathered rocks that were produced by a great diversity of volcanic and postvolcanic activity.

The various sites differ in their microclimates, but also in their dormant forces under foot. The now cool inferno of volcanoes contains and releases different minerals of varying concentration underneath each vineyard. In certain locations, the rocks weather and crumble, nourishing the vines through the soil, but next door millions of years may have been unable to coax any nutrients out of the depths.

In Northern Hungary, including Tokaj, grape growing and cellar construction date back to an eastern legacy, rather than to the Roman heritage. This must have had a lot to do with the Kabar tribe, whose members arrived and settled down in the Carpathian Basin together with the ancient Hungarians, and were well-versed in the art of building in underground rock.

Hungarians brought and bequeathed the traditions of the wine-cellars to the posterity from those times more than 1100 years ago.

The best vineyard sites occupy the southern slopes where they are protected from northern and northwesterly winds by relatively tall forested peaks. To the south, these same sites overlook flatlands, which warm up faster and thus prevent frost from clinging to the slopes, but maintain high humidity through their bogs. At the crack of a Fall day, the hills often afford superb views of the vineyards of Tokaj wrapped up in a blanket of mist. Yet more importantly than the beauty that first meets the eye, these mists nurture *Botrytis cinerea*, the mold responsible for shriveling the grapes and thus, ultimately, for giving us Tokaji.

Authenticity

Searching for clues in time, we cannot even begin to say for sure in what form viticulture existed in the Foothills of the Tokaji Wine Region during the time of Hungarian settlement 1100 years ago. Although we have no material evidence, we can be quite certain that Hungarians already grew grapes and made wine in these early days. Hungary's viticulture has a twofold origin: It is partly nourished by western and Latin roots, and partly by eastern traditions. For a long period, Hungarians had lived in the antechamber of the Caucasians, where they acquired their winemaking skills. Proof of this are those vocabulary items which found their way into the Hungarian language around this time as Turkish loan words, like

szőlő (“grape”), csiger (“marc wine”), bor (“wine”), ászok (“cask”). As they occupied what became their permanent homeland in the Carpathian Basin, Hungarians were probably aware early on of Tokaj’s excellent potential for growing grapes, and they tried to transplant the knowledge they had accumulated in the Caucasians.

From the second half of the 12th century, when Walloon settlers arrived, we can clearly talk about viticulture in Tokaj; one hundred years later abundant records attest to the fact that grapes were grown throughout the area.

After 1526 the Tokaji Wine Region started to play a more and more important role since Hungary lost its best vine-growing areas in the South in the Mohács battle. A proof of the continuous agricultural land use activity since Medieval times is the special interior structure and architecture of settlements of the settlement system that adjusts itself harmonically to the land.

One key to understanding the society and spirit of the Foothills of the Tokaji Wine Region is the oppidum (market-town), a special type of settlement unique to Hungary. The upswing of rural commodity production, generally in the 14th century, strengthened larger villages in commercially important locations. In time, these communities developed their own institutions of local government and obtained certain privileges, such as the payment of tax in a lump sum instead of individual payments by every dweller.

From the mid-17th century on, the flourishing oppidums came under an all-out attack from the landowners. One of the two groups that mounted a successful resistance to this attack consisted of the large, Ottoman-ruled towns on the Plain that had absorbed the population from the abandoned villages and became the property not of the Spahi, but of the Treasury as territories of distinguished value. Their economic prowess relied on the extensive rearing of

gray cattle and on brisk trade, which supplied them with enough cash to appease the gluttony of the Ottoman dignitaries by peaceful means.

The other large group of the oppidums that managed to negotiate survival comprised settlements specialising in wine. Especially successful among them were the proud oppidums of Tokaji region, each with a firm sense of identity which developed an unusually dense network in this region. Sárospatak, Sátoraljaújhely and Tolcsva had won oppidum status before the 1300s; Tokaj, Tarcal, Olaszliszka, Szerencs, Tállya and Abaújszántó in the 15th century; Erdőbénye and Mád in the 16th, and Bodrogkeresztúr in the 17th century. Some of them were destroyed more than once, but they always rose from the ashes. The grape-growing, wine-making serfs, artisans of the oppidums, together with the nobility who moved into them in increasing numbers, were quite successful in defending the rights of these settlements. The oppidums saw their halcyon days in the 16th and 17th centuries, and left us memento of wonderful buildings and monuments.

A unique architectural value of the area is the rich variety and mixture of the architecture of the aristocracy, the great domains, the forming middle class and the peasantry architecture of the area.

d) Criteria under which inscription is proposed

Based on paragraph 24 criteria a/iii, a/v and b/ii of and paragraph 39 criterion ii/b from the criteria mentioned in the operational principles of UNESCO, we propose Tokaji Wine Region on the World Heritage list on the grounds of the following reasons:

Paragraph 24, criterion (iii): *“bear a unique or at least exceptional testimony to a cultural tradition or to a civilisation which is living or which has disappeared”*

The present state of Tokaji Wine Region reflects a unique land-use civilization that has been existing for centuries and the related cultural traditions. With centuries-old experience grape cultivation and viticulture still make use of the unique geographical, geological, geomorphologic, hydrographical and climatic conditions of Tokaji Wine Region.

The lifestyle and civilisation based on this are still organised in accordance with a centuries-old legal system even these days.

This exceptional cultural tradition and civilisation have ensured immigrants of various nations – Saxons, Swabians, Russians, Polish, Serbs, Romanians, Armenians, and Jewish - live together harmoniously for centuries in this region.

Paragraph 24, criterion (v): *“be an outstanding example of a traditional human settlement or land-use which is representative of a culture (or cultures), especially when it has become vulnerable under the impact of irreversible change”*

The cultural landscape of Tokaji Wine Region is an outstanding example of a traditional human settlement and land use which is representative of a culture.

The present character of the diverse and extremely attractive cultural landscape of

Tokaji Wine Region is the result of millennia-old land-use forms based on viticulture.

The site has always been populated since the Middle Ages, and land-use patterns have remained unchanged.

Land use and the multi-national residents' way of life have always followed the varying natural conditions. The economic basis has primarily been viticulture and grape cultivation.

From cultural, historical, topographical, environmental and ecological viewpoint, Tokaji Wine Region cultural landscape is the document of land-use tradition that has remained unchanged for centuries.

The unaltered tradition of viticulture land-use is evidenced by not only the present vine-yards of the region but also the dwellings of the proposed area and buffer-zone that have displayed the special construction form of a civilisation and culture in which the lifestyle of aristocracy and peasantry, wanderers and provincial dwellers, Hungarians and immigrants have formed a unity and do so these days as well.

Paragraph 24, b (ii): *“be legal and/or contractual/or traditional protection and management mechanisms to ensure the conservation of the nominated cultural properties or cultural landscapes. The existence of protective legislation at the national, provincial or municipal level and/or a well established contractual or traditional protection as well as o adequate management and/or planning control mechanisms is therefore essential and, as is clearly indicated in the following paragraph, must be stated clearly on the nomination form. Assurances of the effective implementation of these laws and/or contractual and/or traditional protection as well as of these management mechanisms are also expected. Furthermore, in order to preserve the integrity of cultural sites, particularly those open to large numbers of visitors, the State Party concerned should be able to provide evidence of suitable administrative arrangements to cover the management of the property, its conservation and its accessibility to the public.*

Written evidences of the management and protective measures of Tokaji Wine Region date back to the early 1600s.

In the beginning of the 17th century the settlements of Tokaji Wine Region created a common legal system that concerns the defence of vine-yards. Statutory defence was started with decree of 1737 of the emperor Charles VI (Charles III Hungarian king). The king declared the area almost the same as the property plus buffer zone to be a closed wine region, the first in its kind in the world.

The defence was strengthened by classification of vine-yards that dates back to 1730, 1765, 1772. Even today there is strong classification in Tokaji Wine Region. In 1893 the first Act on Wine Management was passed and it was followed by other acts in 1908, 1924, 1936 and 1997, and in 2000 a Regulation of Wine Management in Tokaji Wine Region was decided.

Paragraph 39, category (ii): “...originally evolved landscape. This results from an initial social, economic, administrative, and/or religious imperative and has developed its present form by association with and in response to its natural environment. Such landscapes reflect that process of evolution in their form and component features. They fall into two sub-categories: (the second is relevant)

- a continuing landscape is one which retains an active social role in contemporary society closely associated with traditional way of life, and in which the evolutionary process is still in progress. At the same time it exhibits significant material evidence of its evolution over time.

The cultural landscape of Tokaji Wine Region is an organically evolved landscape. It has developed its present form by association with and in response to its natural environment and reflects this process of evolution in its form and component features.

The Tokaji Wine Region cultural landscape represents a continuing landscape which retains an active social role in contemporary society closely associated with the traditional way of life, and in which the evolutionary process is still in progress. At the same time it exhibits significant material evidence of its evolution over time. There is a close interaction between existing landscape features and agrarian forms of land-use.

The natural environment has remained a source and means of subsistence for the local population, as expressed by a number of architectural monuments around.

Also the organic unity of cultural and natural dimensions in the Tokaji Wine Region cultural landscape continues to be part of the social structure, current economic activity, agrarian land use and general way of life.

The unique and easily identifiable zonal structure of the Tokaji Wine Region is a natural geographical condition and a result of land use and viticulture alike.

Agrarian land use, however, is not only evidenced by the zonal structure of the landscape but also by the spatial organisation and character of the built environment.

The settlements of the region are of medieval origin, the land-use and architecture reflect the oneness connected to grape cultivation and the social diversity that is characterised by traditions of aristocracy, citizenry, peasantry, Hungarians and people with different languages and religions.

III. Description

a) Description of property

The proposed property and its buffer zone are located in the north-eastern corner of Hungary, in the area of Borsod-Abaúj-Zemplén County. The chief-town of the county is Miskolc. The buffer zone borders upon the Slovakian Republic in a short distance. The area of the county is 7248 square kilometres, the population is 735000.

Geological, relief and hydrographic characteristics

Geographical borders of the nominated property and buffer zone: inner areas of Zempléni Mountains in the north, Hungarian-Slovakian border and the River Bodrog in the east, a short part of the River Tisza and Taktaköz in the south and Hernád-valley in the west.

The eastern part of the area under investigation is situated on the Szerencsi hills. Its surface is composed of ridges of a hill in an approximately north-south oriented strike, the average height of which is 250 metres above sea level. The average value of the relative relief is 70 metres per square-kilometre. More than 80% of the surface is covered by sarmatian rhyolite tuff. Its elevations are bare rhyolite and riodacite cones. Its precious mineral substances are zeolite, kaolin, hydro-quartzite and bentonite. At the foot of the hills, in a south-south-eastern direction from the Tokaj mountain, we can find a 150 metres deposit layer of gravel, sand, warp and fresh water burden. In the upper layers the soil is composed of brown soil developed on lymph-like clay, while in the lower layers it is characterised by chernozem with patches of lime.

The core of the Tokaj hill, which constitutes the southern peak of the Zemplén mountains, is made up of andesite, rhyolite and rhyolite tuff. The foothill slope is

covered by loess up to the height of 250 metres in a cone-like way. At lower parts its thickness can reach up to 30-40 metres. The average relative relief of the hill is 117 metres per square-kilometre. Its natural substances are andesite and rhyolite tuff. Its determining soil type is the acidic brown soil developed on lymph-like clay.

The average height of the slope ranges exposed to the south-east, north and west-north-west direction from the Tokaj hill is 514 metres above sea level. More than 80% of the surface is endangered by soil erosion. The degree of the annual erosion reaches 1 to 3 centimetres. Under the surface the product of the volcanic post-activities can be found, the surface is covered by solifluctional deposit or at some places by loess. Among the natural substances zeolite, kaoline and bentonite are substantial. It is also possible to find andesite, flint and hydroquartzite here. 55% of the soil is brown forest soil developed by clay infiltration and 34% is brown soil. The proportion of the barren stony areas is only 4%.

Bodrogeköz is situated between the wave band of the Bodrog and Tisza, beneath the above mentioned slope range. The little region is a flat area between 95 and 128 metres high above the sea level. The average relative relief is 4 metres per square-kilometre. The 90% of the surface is dominated by Neoholocene casting formations, such as meadow clay and marshy deposits. Its soil is mainly determined by chernozem as well as marsh soil and to a smaller extent sodic soil.

The most significant water resources are the Bodrog and the Tisza rivers as well as the backwaters and oxbows created after their regulation. The water reservoir at Tiszalök made the Bodrog navigable, too. Other significant, but smaller water flows in the area are the Szerencs brook, the Gilip brook (dammed to a 39 hectare water surface next to Monok), the Tatka channel, the Fennsík channel (created by the confluence of Fördő and Mádi-brook), and the Ronyva, Hercegekúti, Szarkakúti, Tolcsvai and Bényei brooks, respectively, flowing into the Bodrog. Most of them are seasonal or abate during the summer.

Local climatic characteristics

Higher areas are situated at the border of the moderately wet zone, the lower areas belong to the moderately hot and dry climate. The amount of sunshine is around 1900-2000 hours per year, in summer the average is between 750 and 790 hours, while in winter it is 200 hours on average. The annual mean temperature is between 9.6 and 9.9 °C, during the vegetation season it is around 16.3-16.9 °C. The daily mean temperature is over 10 °C over about 184 days a year, namely between 14th April and 14th October. On average the daily mean temperature does not go below freezing for 180 days but on the southern slopes this period may last longer than 190 days. Between 20th April and 15th October the temperature is above freezing. The mean of the highest degrees within a year is 33°C and the lowest is -16°C. The annual amount of rain is around 600-620 mm out of which 370-390 mm arrive in the vegetation season. Its climate makes it possible to grow cultivated plants that require hotter climate. The Tokaji Wine Region is perfect for cultivating grapevines, while the flatter areas provide perfect conditions for growing plants on tillage and at places with high subsoil water level grazing and grassland farming would be preferable.

Flora and fauna

The area according to plant geography classification can be ranked among Tokajense flora locality of the larger North-Hungarian mountains flora area (Matricum) within the Hungarian flora land (Pannonicum). Hornbeam and Turkey oaks (*Quercus petraea*-*Carpinetum*, *Quercus petraea*-*cerris*) form the climatic associations on the less typical slopes exposed to the north and in the more fresh valleys. On the south-facing slopes the thermophil oak (*Corno-Quercetum pubescenti-petraea*) is peculiar. *Cornus mas* (Cornelian cherry), *Crataegus monogyna* (singleseed hawthorn), *Viburnum lantana* (Wayfaring tree) and *Amygdalus nana* (dwarf almond), which can be found in large number in some places, are the most remarkable among the shrubs. Mostly in warmer location it is

more frequent to find soft-stalked plants such as *Iris variegata*, *iris graminea* ssp. *pseudocyperus*, *Aster cinereus*, *Lathyrus pisiformis* and *Stipa stenophylla*. 17 species of orchid live on Kopasz mountain.

Forests mostly consist of non-native pine- and locust-trees. The damaging effect of the former one is changing the chemical properties of the soil: the fallen pine needles sour the soil strongly. The latter one consumes the nutritives of the soil, practically exploiting it, while forming an ineradicable polycormon colony. Both have the effect of totally thinning out their undergrowth because of the deep shadow (pine) and allelopathical features (locust), and they do away with the territory of valuable soft-stalked populations.

The most typical cultivated plant of this area is grape-vine, but in southern locations there is also peach, plum, and rarely almond. The most typical plough-land grain is wheat, but we can also mention maize, rye and sunflower.

Regarding the animal population, the regions of Tokaj-Bodrogszug Landscape Protection Area has the most important role. It is a significant nestling and brooding place for birds and rich in fish. The most tipycal and precious species are the night heron, spoonbill, common heron, cormorant, white stork, Short-toed Eagle, Imperial Eagle, Lesser Spotted Eagle. Two of the seven or eight pairs of stock owl known in Hungary live on Nagy-Kopasz.

In the stock of game there are big populations of rabbit, deer and wild boar living in the forests above vine-lands and meadows. Animal keeping is not considerable.

Tokaj-Bodrogszug Landscape Protection Area is quite prominent among nature conservation territories, and also the examined parts of the Landscape Protection Area of Zemplén, but we can mention some nature conservation areas with local importance protecting the same value and the individually protected species of different plant and animal.

Areas of protected nature: Tokaj-Bodrogszug (District of landscape protection; partly covering the property only), Bodrogszegi Várhegy (Protected area), Tállyai

Patócshegy (Protected area), Zempléni District (District of landscape protection; partly covering the property only), Erdőbénye woody pasture (Protected area) (see map 4. in Annex),

Cultural property

Settlement-related and architectural values

The settlement system and the settlement forms of the Tokaj Wine Region are inseparable from the morphological and hydrographical features of the area.

One of the frames of the interrelationships between settlements and of the settlement system of the region is the Bodrog, and the other one is the Stream Szerencs and the River Hernád at the western border.

There is a chain of settlements along the Bodrog. These settlements are located on the right bank of the river meandering at the foot of the Zemplén mountain range. Bodrog is one of the water-collecting rivers of the mountain range, and there are further settlements to be found in the valleys of the smaller streams falling into the Bodrog. The Bodrog is emptying into the Tisza at Tokaj, marking one of those ancient passing-places which provide the settlements between the two banks of the Tisza with connection.

The Szerencs is falling into the Takta through a broad mouth, having settlements on its both sides. The extremely valuable capabilities of the area, and its aptitude for being a good place to settle down had already been recognised by the first Magyar settlers of Hungary. The name Tokaj itself, coming into Hungarian as an Armenian loanword meaning ‘grape’ at around the 10th century, is an evidence for the early origin of the settlement, its system of ethnical relationships and the fact that viticulture was known at that time. The changing of the area into wine region deeply influenced the thinking and culture of the local population. However, by the conversion of the area into wine region, we do not only mean regal

regulations, but rather the uniformed environmental culture typical of Tokaji Wine Region, that can be identified even these days.

In the built environment of the region, the architectural cultures of many centuries are intertwining in a unique way: there can be found Catholic churches of medieval origin, Orthodox churches from the 18th-19th century, monuments of the and Jewish sacral architecture, documentaries of the princely architecture of castles, castles and mansions of the aristocracy as well as dwelling-houses, wine houses and cellars of the people.

An important monument of the early settlement of the area is the Roman style Catholic church in Bodrogolaszi from the 12th century, situated in the buffer zone.

In every settlement of the nominated property there can be found a gothic Roman-Catholic church from the Middle Ages.

In Tokaj and in Tállya, there are ruins of castles from the 14th century, and among settlements in the buffer zone, it is Monok, Sárospatak and Szerencs where there are Medieval castles.

The noble castles and mansions are the emblems of the wealth gained from viticulture, from which four of them are standing in Tarcál, and another nine are in the buffer zone. These buildings were built in the 18th-19th century, in the glory of the Tokaj Wine Region.

The synagogues and other sacral buildings in Tarcál, Tokaj and Mád, the Orthodox and Roman-Catholic churches of Tokaj, and the Orthodox churches of Abaújszántó, Bodrogkeresztúr, Bodrogolaszi, Sárospatak, Sátoraljaújhely and Szerencs, all protected by the Ancient Monument Act were also built at this time.

The density of monuments is marked by the protected areas of monuments, of which one happens to be in Tokaj and the other one in Tállya, and another ten are situated in the settlements of the buffer zone.

The most typical establishments of Tokaj are the cellars. The cellar of King Kálmán in Tarcál was already mentioned in 1110.

The two basic cellar types preferred in Tokaj were the vaulted and the carved varieties. The vaulted was basically a space underneath a residential building, both with an identical floor plan. The cellar was usually dug when the house itself was built, and mainly accessed from the porch. In this set-up, the grapes were processed in a room to the rear of the house, just above the cellar.

The other version, the carved cellar was not directly linked with the building. On the surface level, only a stonework entryway with a latticed gate made from wood or steel was visible. The cellars carved in volcanic tuff did not need to be reinforced with vaults because the rock was strong enough to support the ceiling. In Tokaj, 80-85 percent of all the cellars were made this way.

The most interesting type is the multi-level cellar labyrinth with a jumbled floor plan. Created over the centuries by horizontally and vertically linking cellars carved near each other, these mazes appeared in the commercial centers of the Foothills of the Tokaji Wine Region, in Erdőbénye, Mád, Tállya and the town of Tokaj. Their most famous example is the cellar network in the Ungvári district of Sátoraljaújhely, which evolved through interconnecting 27 separate cellars side by side and one on top of another. This labyrinth has the capacity to hold 13000 casks of the Gönc and Szerednye type.

This cellar labyrinth, the Ungvári Cellar in Sátoraljaújhely is part of the nomination. The historically unique and attractive Rákóczi Cellar in Sárospatak, that has 1000 metres long ways, is also part of the nominated property. Within the nominated property, there are several similar and valuable cellars like those.

Sátoraljaújhely, Ungvári Wine-Cellar

In the deed of foundation of Sátoraljaújhely, there are mentions about the origin of the wine-cellars going back to the 1200's. The original settlers went to the foothill of the Sátor hill from the floods of the Bodrog river, and probably used the cellars, excavated in rhyolitic tuff, for food storing and as shelter from their enemies.

The value of Tokajhegyalja and thus the district of the Ungvári cellars rised up along with the decay of the South-Hungarian vine regions in Szerémség, during the 16th century invasion of the Turks.

Denomination of the cellars derive from their situation along with the wine-transporting main road, going in the north-eastern direction, which road goes through the city of Ungvár.

In its present form, the Ungvári wine-cellars are on a 50.000 m² open air area, in the northern part of Sátoraljaújhely. The 14-16 km long, four storied wine-cellars has been elaborated through the horizontal and vertical contraction of 27, originally individual cellars, whose storing capacity is 13.000 barrels from Gönc and Szerednye, (20.000hectolitre i.e. 528.000 gallons). It is a labyrinth type winery. The base width of the branches is 180-200-250 cm, their height is 170-190 cm. Characteristic decoration of the cellars are the so-called circle branches, that vary from 6-8 m through 20-25 m up to 50-60 m in length. The conformation and maintenance of the expressively good cellar climate is supported by more than 15 m deep main ventilating holes, and smaller ventilating holes connecting the individual levels.

The basic value of the winery is implied in its special micro climate providing due maturation of Tokaji wine specialities – Szamorodni and Aszú wines. The optimal regulation of air motion is actuated through the controlling of the ventilation holes and the so-called air-doors. It is supplemented by the grey-black mould, *Gladosporium cellare* on the walls of the cellars. As a result of all these, the temperature of the cellars is between 9-11 °C, the relative humidity is between 85-95%, all through the year.

The Ungvári Cellar is the property of the state-owned Tokaj Kereskedőház Rt (Tokaj Trading House Co.).

Sárospatak Rákóczi Cellar

This cellar is situated in the historic centre of Sárospatak, 14 metres deep under the park of the Rákóczi Fortress-Castle (in volcanic rock). Its total length is about 1000 metres, accommodating tokaji wines, and thus, one of the largest and most beautiful winery of Tokaji Wine Region (Hegyalja), as well as a living proof of the wine and vine-culture of Hegyalja and Sárospatak, going back to the Árpáadian age (10th-13th century). It is duly enlisted as a historic site of Sárospatak, since it has been the property of famous personalities of the castle and the region since the XVI. century, being one of the repositories of their wealthy. The past of the cellar under the fortress park is known back to the times of Péter Perényi, who erected the fortress between 1534 and 1541. Its major owners were King Miksa I and Dobó Ferenc. In 1612 it got in the propriety of Mihály Lorántffy. As a result of the marriage of György Rákóczi I - the prince of Transylvania - and Zsuzsanna Lorántffy the estate increases significantly, thus the winery passes to the property of the Rákóczi princes until the fall of the Hungarian independence war (1711). The owners after that were as follows: the princes of Trautsohn between 1712 and 1776, the princes of Bretzenheim between 1806 and 1875, princes of Windisch-Graetz between 1875 and 1950. From 1951 it was a property of the Tokajhegyaljai Pincegazdaság (Tokajhegyalja Winery), whereas from 1971 it was handled by the Tokaj State Farm Wine Combinate. At present – since 1992 – it is owned by Megyer Rt. (Megyer Inc.). The cellar reached its final extension between 1776-1791, there has been no enlargements or restructuring since that time. Humidity in this cellar of excellent consistency and constant climate is 96%, which is provided by the velvety grey-black mould (*Gladosporium cellare*) growing steadily and thickly on the walls. The *Gladosporium cellare* is an individual feature of the Tokaji cellars. This special mould, is in close connection with the Aszú and Szamorodni wines. The wine is necessary for the growing of the mould, and it gives special character to the wine. Thus the cellar is capable of seasoning excellent quality and high consumption value Szamorodni and Aszú wines.

The winery can accommodate 900 pieces of “Szerednyei” barrels, which barrel is a peculiarity of Tokaj-hegyalja.

There are two taster chambers in the cellar. In the Great Taster, which may room 80 people, large groups can be received. The Small Taster may accommodate only 14 people. There are 7 coats of arms above the tables, symbolising the most important settlements of the region: Sáropatak, Tarcál, Tokaj, Mád, Tállya, Sátorajújhely, Tolcsva.

Another historic sight of the cellar is the Rákóczi bacon fryer, where – most probably – the Rákóczi family tasted its wines.

In 1957 a museum has been established on purpose of conserving the best vintage Aszú wines and rarities for the posterity.

The owner of the Rákóczi Cellar is Megyer Rt. (Megyer Inc.). The firm utilises this famous winery of historic past in the fields of viticulture and tourism.

Archaeological values

A geological-archaeological celebrity is the *Vitis Tokaiensis* that is one of the finds that date back to the Miocene flora and was found here, in Erdőberénye. This ancient grape-leaf, which can be regarded as the ancestor of each and every grape-type, proves that the grape is a pre-historic endemic plant in Tokaj. The primary vine, the *Vitis sylvestris* is growing wild in Tokaj even nowadays.

In the Neolithic in Boldogkőváralja, there was a human settlement in which people dealt with making obsidian and flint implements. (Obsidian finds: Erdőberénye-Liget, Aranyosvölgy, Erdőhorváti etc.). People using copper and bronze tools (“culture of Bodrogkeresztúr”) used to live in the Northern foreground of the Tokaj mountain (Dereszla-tető, Henye). Finds from early Bronze Age (“culture of Hatvan”): at the boundaries of Tarcál, Mézesmál-tető, Szerencs, Mezőzombor, Erdőberénye and Sárzasadány.

Bronze Age finds: Tiszaladány-Nagyhomokos (Ürgehát)

Bronze Age: finds of the “culture of tumuli” in Rakamaz

pots from the “culture of Füzesabony”: Tokaj, Szerelmi dűlő (Parcel of Love)

finds from the “culture of Piliny”: Tarcal, Mád, Bodrodkeresztúr, Tokaj (motorway)

finds from the “culture of Gáva: the area of Tokaj, Szerencs, Tállya Mád, Tarcal, Tolcsva, Bodrogkeresztúr

Finds of the migration period: Vandal settling: Tiszaladány-Nagyhomokos

Hun finds: Mád, Végardó, Tiszaladány

Avar findspots: Tiszadada, Tiszalök, Tiszaeszlár, Bashalom, Tiszanagyfalu

Pots of the migration period: Tokaj, Szerelmi dűlő

Finds, pots and establishments from the Árpád Age:

the “tomb of the Leader Tarcal” in tarcal, above Mestervölgy, tomb of a leader in Rakamaz (in both of them there is a sword of the leader, the famous silver satchel plate etc.)

in Rakamaz-gyepföld: silver disk with griffins used as a hair ornament

in Karos: a tomb of a leader (sword, silver satchel plate, sun-disk)

in Kenézlő: populous common cemeteries

in Tiszaeszlár: tombs of a leader and of militants, common cemetery, village of Tiszalök-Rázompuszta

in Mezőzombor: female tomb of high rank

the tomb-site in Sárospatak

“treasure of Tokaj” silver-set in Zalkod-Szegfarka

earth fortification from the 10-11th century in Szabolcs

Hymesudvar (earth fortification of Tokaj), around 1200

(The most important items of cultural heritage are plotted onto the 6.map - Annex 1e)

b) History and developments

Tokaj is claimed by many with certitude to have been the centre of Attila's Hun empire. This claim may well be true. What is an undisputed fact, however, is that the region became all-important for the occupying Hungarian tribes, who cherished their kinship with the Huns.

The salt-road coming from the salt-mines of Máramaros leading to Buda used to cross the Tisza at Tokaj foothills, so that is the place where the Polish merchants travelled to the Balkans and to Transylvania or to the Upper-Hungarian regions. The crossing-place at Tokaj was created in the crossing of roads and war roads.

Soon enough after they had arrived, the Hungarians settled the area of Tokaj and, even before that, the Bodrogköz, where they found shelter in the bogs between the bifurcating waters. Hungarians here enjoyed relative protection for the next eleven hundred years. How much this refuge was needed became obvious in 1241, when it was through this region that Batu Khan's Mongolian hordes invaded the country to run down the Hungarian royal troops on the Muhi Puszta, just a few kilometers south of Tokaj. Although the Tartars failed to capture Sárospatak, the most prominent fortification in the area, a quarter of Tokaj's inhabitants perished during the year and a half of the Mongolian Occupation.

In the first centuries of the Hungarian Kingdom, the decisive part of the Tokaj region belonged to the Crown, while Patak (short for Sárospatak) and Szerencs served as the headquarters of the ispán, the land-steward reporting to the royalty. Through donations, the original crown properties were turned into feudal estates controlled by the local nobility by the 13th century.

The flourish of Hungarian viticulture owed a great deal to Latin peoples who found a new home in the country. They often arrived in the company of German settlers, or else they would found towns together with them. The Latin presence proved especially crucial in the Szerémség, in Southern Hungary one of the most important Hungarian wine regions prior to the heyday of Tokaj. In fact, the Latin peoples are assumed to have added an entire chapter to the history of the Foothills of the Tokaji Wine Region, albeit only scant evidence—material or written—

remains to support that claim. Latin settlers were first invited to settle down in Tokaj by Béla III (1130-1162), and then by Béla IV (1235-1270). By all likelihood, these immigrants were Walloons from Northern France, subject to being lumped together in Hungarian with all the neo-Latin peoples as *olasz*, meaning “Italian”. However, certain researchers claim that these early settlers had indeed come from Italy, and were arguably—if not verifiably—responsible for propagating the Furmint grape. The memory of these settlers is enshrined in the names of villages such as Bodrogolaszi, Olaszliszka, and presumably Tállya.

The Felvidék, or Upper Hungary, has been home to Germans since the infant centuries of the Hungarian State. They settled in the Szepesség forming a tight community, and generally maintained a decisive presence in the towns. Eventually, most of them blended in with the Hungarian matrix, but persisted in their identity for a long time in terms of culture and tradition.

The barons finally bowed to the House of Anjou (1308-1387) that had followed Árpád’s Dynasty (895-1301), but in the 1500s, under the reign of the Hunyadis, the Upper Country fell under the dominion of a new foe, the Czech Jan Griska. As the leader of the Hussites, a religious group driven out from the Czech lands, Griska resisted Hunyadi Mátyás (Matthias Corvin) for a long period of time. When he was finally defeated by this last great Hungarian king, he became one of the most loyal subjects of the crown. The memory of the Hussites is still guarded by a handful of characteristic buildings along the Hernád. In the 14th and 15th centuries, the valley of this river played a role perhaps even more remarkable than that of Tokaj. It was itself abundant in thriving vineyards, but its essential advantage consisted in its geographical-economical location.

In the first half of the 16th century, one third of Hungary fell under the Ottoman Occupation.

Tokaj was a veritable no man’s land in those days. It fell outside the territories under Ottoman rule, but remained vulnerable to raids. Although the area formally belonged to the Hungarian Kingdom, through cultural and political ties it was

closely attached to the Transylvanian Principality, which remained a huge sore in the eyes of the Habsburg Court for its successful resistance. Due to its geographic position in a shredded country beleaguered by incessant uncertainty and strife, Tokaj became a site of deployment by the second half of the 16th century.

At the earliest, the birth of Tokaji Aszú can be dated to around 1630, the year that newcomers to Tokaj will generally be told first. Legend has it that in that year, Szepsi Laczkó Máté, evangelist of Erdőbénye and pastor at Lórántffy Mihály's domain, wanted to lead the villagers to the harvest as usual, but fears of an Ottoman incursion held them back day after day. By the time they finally did venture into the vineyards, botrytis infection had set in and shriveled the grapes. The workers proceeded to pick these crinkled berries anyway, and the pastor placed the wine made from them as an Easter gift on the table of Lórántffy Zsuzsanna, daughter of his lord and who was engaged to Rákóczi György I, Prince of Transylvania.

At the beginning of the 17th century, the Transylvanian principality was then acquired, although only held for two years, by the founder of a dynasty, the Rákóczis, which became one of the most prominent families in the annals of Hungarian history, and whose destiny was intertwined with Tokaji's rise to world fame.

Rákóczi György still held the throne in 1631, the year for a long time believed to be the official date of birth of Tokaji Aszú. In fact, the wine of Tokaj had already been a major source of income for the Rákóczis, and thus served as a pillar of the Princes' power. As the fame of the magnificent drink reached ever farther, more and more wealth was accrued by the local culture.

The dawn of the 18th century saw the last great member of the family step into the arena of history. The moment of Rákóczi Ferenc II came when the Ottomans had been driven out of nearly all of Hungary, and it seemed that no one would be able to resist the Habsburg Court. Coming into an inheritance after a turbulent childhood, Rákóczi Ferenc II swore to the Catholic faith, but he really thrived on

the same ideals as his Protestant ancestors. He was destined to be chosen, in 1703, as the prince who would lead Hungary's longest ever war of independence.

During the eight years of the war, Ferenc forged a solid network of international relations. While Tokaji Aszú, the most valuable treasure of his holdings, had for decades generated the revenue needed to carry on the struggle for independence, so did the fame of the wine ascend in the wake of that heroic effort. Tokaji Aszú made money as well as nurtured relations. It was a commodity, but it also served as a special gift that paved the Prince's way into the courts of Louis XIV, King of France, and of the Russian Emperor, Peter the Great. Tokaji was esteemed as a precious rarity—as “the wine of kings and the king of wines.”

The drive for independence led by Rákóczi Ferenc II was defeated in 1711. The Prince fled to Turkey, leaving his estates in Tokaj to the monarch in power. Over the remaining nine decades of the 18th century, Hungary slowly found its position within the Habsburg empire, but it never relinquished its separate identity. The 150 years of anguish were now followed by peaceful times in comparison. Relying on a steady market demand and a tradition of wine-making that had been honed for centuries, Tokaj enjoyed relative prosperity through most of the period. In fact, by 1780, the Foothills of the Tokaji Wine Region became the most densely populated region of the country. Its rate of 52 inhabitants per square kilometer was nearly double the national average, and it even exceeded that of France or the more advanced German states. Tokaji was highly in demand, and the estates were constantly short of helping hands. The élan of the 17th century remained tangible in these more tranquil times. Poland emerged as a distinguished market for Tokaji, and the Russian emperors maintained in Tokaj what amounted to a colony commissioned to supply the Court with the excellent wine.

The Tokaji had had a great attraction for the people of the surrounding areas from the very beginning.

The Slovaks typically settled down in the northern reaches of the Zemplén, now part of Slovakia, and in tiny villages deep in the interior of the same range. They

were regarded as hard-working day labourers who knew how to work with timber and wood, and who often worked in the vineyards of Tokaj.

The Orthodox Ruthenians kept coming into the area from the 16th to the 19th century.

From 1733 to 1798, the Russian Czars ran a small colony that they called the Wine Purveyors' Commission in Tokaj, to ensure a steady supply of the excellent wine (originally set up by empress Anna Ivanovna).

The Greeks emerged as major players in the trade of Tokaji toward the end of the 17th century, and they held on to that role until the late 1700s. They were moved to the town of Tokaj by Rákóczi Ferenc II after Szatmár had been captured, and they soon found a niche in the community. Most of them were of Macedonian extraction, and ultimately only few decided to choose the Foothills of the Tokaji Wine Region as a permanent home (an example was the Konstantin family in Tolcsva). As Turkish citizens, the Greek merchants were rarely distinguished by the locals from their Serbian and Armenian colleagues.

Starting in the late 1700s, they were slowly superseded by the Jews, who arrived and settled in increasing numbers. Historians have shown that, from the beginning of the 17th century, Polish Jews had commercial interests in the wine of Tokaj. The first major wave of Jewish emigration to Hungary, triggered by the insurrection of Hmelnitzky's Cossacks in 1648, reached Tokaj in the second half of the 18th century. The most important Jewish communities were formed in Mád, Tolcsva and Sátoraljaújhely, and later in the town of Tokaj. When the second wave hit between 1800 and 1867, the Jews came to play a significant role in the business of each community in the Foothills of the Tokaji Wine Region, and a decisive one in its wine trade.

The 19th century was a period of gradual impoverishment, and also of continuously searching for a way to once again put Tokaji on the table of the most discriminating consumer.

The end of the century saw a well-known problem hit Tokaj: Phylloxera duly appeared on the scene. It raised its head at the relatively late date of 1885, but when it did, it promptly proceeded to destroy most of the vineyards in a matter of a few years.

The Jewry was wiped out by World War II; ownership by the aristocracy and the few smallholders about to join the bourgeoisie was abolished by the communism that followed it. In this way, those who had formed the decisive, most skilled and most apt force behind the growing and trading of wine in Tokaj vanished or drifted to the margins of life.

The political changes in 1990 shook Hungarian society to its foundations, releasing processes from the grip of slumber with elemental force. Once again, the best were given a chance to create the best, in Tokaj and elsewhere in the country. And Tokaji was indeed reborn.

c) Form and date of most recent records of property

Land registry

1: 4000 scale up-to-date uninhabited area cadastral maps and database with public authenticity are available in the district land register administration (Miskolc).

Topographical maps

The most up-to-date topographical map is available from the Hungarian Armed Forces Mapping Office in analogue and digital form (scale: 1:50000, see Annex 2 – Topographical maps).

The 1:10000 scale EOVS projection system topographical map of the area is available. Similarly 1:10000 scale maps of the Gauss-Krüger projection system are available. A part of the information contained in the 10000 scale maps is also available in digital format. Similarly, we have a 1:25000 scale series.

Biotic data

In the database of the Bükki National Park, all the data concerning the protected species within the nominated property are found partly in digital and partly in analogue form. Processing of these data is done continuously as is GPS-based processing of digitised data.

Environmental protection data (including water quality)

Észak Magyarországi Környezetvédelmi Felügyelőség
(North-Hungarian Environmental Protection Inspectorate)
Észak Magyarországi Vízügyi Igazgatóság
(Northern Hungary Water Management Directorate)

Hydrological data

Felső Tisza-vidéki Vízügyi Igazgatóság
(Upper Tisza Region Water Management Directorate)
Észak Magyarországi Vízügyi Igazgatóság
(Northern Hungary Water Management Directorate)

Meteorological data

Országos Meteorológiai Szolgálat
(National Meteorological Service)
Észak Magyarországi Vízügyi Igazgatóság
(Northern Hungary Water Management Directorate)

Archaeological archives

Kulturális Örökségi Igazgatósága
(Directorate for Cultural Heritage)

Historic monument protection archives

d) Present state of conservation

The fine state of conservation of the biosphere is due to the centuries-old land use tradition which has always been in harmony with the available resources. The area has not suffered from any damages of intensive cultivation or industry.

Notably in terms of land ownership and economy and their impact on the respective areas, the situation is to be seen in a differentiated way.

During the past ten years, Hungary experienced an intensive law establishment process having its conceptual basis in the creation of an independent and democratic legislation. Legislation has been aimed at incorporating the EU acquis and achieving a certain level of conformity of individual sectorial legislation as well.

The status and future of the cultural landscape proposed for World Heritage listing is essentially determined by Act No. LIII. of 1996 on Nature Protection aimed at generally protecting the natural values and areas, the landscape and its natural systems, the biological diversity, supporting the acknowledgement and sustainable use thereof, as well as satisfying the demand of society for a healthy and aesthetic natural environment.

Act No. CXXI of 1997 On Grape Cultivation and Wine Management regulates the planting, cultivation and grubbing of grapevines, production, storage and release to the market of grape must, wine and wine distillates, along with administrative tasks and competencies relating to grape cultivation and wine production.

Tokaji Wine Region is given legal defence as a closed wine region. By the Act a production area is considered as a closed wine region if its products are worthy of distinguished protection and require special rules to govern the cultivation of grapes in addition to the production and treatment and distribution of the wine.

Tokaji Wine Region is a cultural landscape which is largely determined by its natural heritage and includes a number of landscape-shaping cultural factors.

The traditional architectural monuments located within the property and the buffer zone are well-conserved regarding the original fabric, original appearance and artistic effect; also the continuing preservation and maintenance of the historic building material is guaranteed.

The built-up heritage is protected by the Act No. LIV of 1997 on Historic Building Preservation.

Although licensed mining areas are excluded from the world heritage submission, considering that they are in close connection with the Core Area and sometimes form its enclosures, it is important to notice that mining is a domestic activity of the area from the primitive times, and it is still an important employment factor. Open air mining is strictly regulated, thus mining seats the life, culture and landscape values of the region.

The basis of this activity is set down in the Act No. XLVIII of 1993 on Mining. The act regulates excavation in accord with life, health, safety, environment protection, private property protection and the management of mineral resources. Mines have their own mining sites, this is the basis of the activity.

Mining activities are bound to the licence of the Inspection of Mines, in accord with the Technical Industrial Plan. Further proviso is the elaboration of a Landscape Plan.

In the confirmation clause of the Technical Industrial Plans, the regulations of the authoritative Environment Protection Inspectorate, National Park Directorate and Water Management Directorate are laid down.

The blast, splinter and seismic effects of the explosions are to be kept on the possible minimal level through due planning and actuation, with the involvement of experts.

The noise and dust burden resulting from boring, exploded stone collecting, its transport, breaking and selecting, must be reduced by technical solutions, and specified environmental limits are compulsory. Instruments to be applied in the field of reducing environmental side effects are modern appliances, such as boring machines equipped with automatic dust exhauster, low noise level excavators, dump trucks, front-end loaders, coating of the installed appliances, the application of wet dust precipitation, dust-absorption of transport corridors, and their covering with asphalt, and the recultivation of abandoned quarries.

e) Policies and programmes related to the presentation and promotion of the property

Policies and programs to present and promote values can be found in every settlement in forms of state, civil or private initiations. Inland and international programs and publications promote the introduction and familiarisation of the region.

IV. Management

a) Ownership

Proposed region and buffer-zone: 881,352 km²

Private and community properties:

In Abaújszántó, Bekecs, Bodrogkeresztúr, Bodrogkisfalud, Bodrogolaszi, Erdőbénye, Erdőhorváti, Golop, Hercegkút, Legyesbénye, Makkoshotyka, Mád, Mezőzombor, Monok, Olaszliszka, Rátka, Sáradsadány, Sárospatak, Sátoraljaújhely, Szegi, Szegilong, Szerencs, Tarcal, Tállya, Tokaj, Tolcsva, Vámosújfalu

Church property: in the settlements mentioned above

State property:

forests, the vineyards of Tokaj Kereskedőház (72 ha) and permanent state property monuments in Mád and Sárospatak

b) Legal status

During the past ten years, Hungary experienced an intensive law establishment process having its conceptual basis in the creation of an independent and democratic legislation. Legislation has been aimed at incorporating the EU acquis and achieving a certain level of conformity of individual sectorial legislation as well.

The status and future of the cultural landscape proposed for World Heritage listing is essentially determined by Act No. LIII of 1996 on Nature Protection aimed at generally protecting the natural values and areas, the landscape and its natural systems, the biological diversity, supporting the acknowledgement and sustainable use thereof, as well as satisfying the demand of society for a healthy and aesthetic natural environment. The law defines the concept of the National Park, regulates

in detail among others the intended use of the protected natural environment including the national parks, the activities that are permitted to be exercised there and provides for buffer zones to be established outside these areas.

On the basis of Act No. XCIII of 1995, nationalisation of National Park land formerly owned by co-operatives will be completed by 2000.

While former laws were meant to protect the unique value of the built environment by protecting each of the elements separately, a new integrated approach has been gaining ground since the 1990s and replacing the former object- and monument-centred view.

The first sign of these endeavours was Act No. LXV of 1990 on the establishment of local self-government, which made the protection of the built environment a task of both the communities and the county-level local governments.

Act No. LIII of 1995 on the general rules of environmental protection includes provisions on the protection of the man-made (built) environment.

Act No. XXI of 1996 on regional planning and zoning sets out the regional tasks of environmental, landscape and nature protection and conservation.

Act No. LIV of 1997 on historic monument protection endeavours to promote the interests of monument preservation within a holistic concept of protecting the built environment with due consideration of area and settlement development, nature and landscape conservation, international obligations and promotion of public awareness of the cultural heritage.

Act No. CXL of 1997 on the protection of cultural assets and museum-type institutions, on public library services and public education provides for the disclosure, preservation, protection and publication of all national and accumulated assets, including the archaeological heritage.

Act No. LXXVIII of 1997 on the formation and protection of the built environment defines as a land use objective the development of the natural,

landscape and built valuables of the environment and the protection of villagescapes and landscapes.

Act No. CXXI of 1997 On Grape Cultivation and Wine Management regulates the planting, cultivation and grubbing of grapevines, production, storage and release to the market of grape must, wine and wine distillates, along with administrative tasks and competencies relating to grape cultivation and wine production.

Tokaji Wine Region is given legal defence as a closed wine region. By the Act a production area is considered as a closed wine region if its products are worthy of distinguished protection and require special rules to govern the cultivation of grapes in addition to the production and treatment and distribution of the wine.

Tokaj-Bodrogzug (District of landscape protection; partly covering the property only) is enacted by the decree 7/1986 OKTH, Bodrogszegi Várhegy (Protected area), is enacted by the decree 6/1990 (VI.18) KÖM, Tállyai Patócshegy (Protected area) is enacted by the decree 2/1987 (VII.10.) OKTH, Zempléni District (District of landscape protection; partly covering the property only), Erdőbénye woody pasture (Protected area)

(see map 4. in Annex),

The Tokaj protected environment of monuments is enacted by the decree 15413/1986 KTM-MM

c) Protective measures and means of implementing them

The Minister of Agriculture took measures concerning grape cultivation and wine management in directives, among others, the obligation of the Certificate of Origin was introduced. The certification is subjected to the control of Wine communities and Wine community councils.

Nature conservation areas are controlled by Authority for Nature Conservation under the Hungarian National Ministry of Environment Protection.

Protection of historic monuments, supervision of maintenance in good operational condition is a task primarily belonging to the Historic Monument Protection Authority.

According to the law on historic monuments, the owner of the asset has to maintain the historic monument in good condition.

The competence for historic monument protection is with the Historic Monument Protection Directorate of the National Historic Monument Protection Authority as a first instance and with the President of the Authority as a second instance. This is also the authority which grants building permits.

Any changes that would influence the state, traditional appearance, historical and aesthetic effect of a historic monument are subject to the consent of the Historic Monument Protection Authority.

Permission by the Historic Monument Protection Authority is necessary whenever land use plans or local building codes affect objects under monument protection. The modification of the boundary of any built-up zone within settlements also requires permission by the Historic Monument Protection Authority if such modification concerns monument protection interests.

In the interest of monument protection, the Historic Monument Protection Authority may oblige the owner to maintain the estate in good state, while technical supervision may request the removal or demolition of elements disturbing the view of the monument.

The Historic Monument Protection Authority may levy a fine if the legal provisions are infringed.

In addition to protecting the historic monuments in its area, the task of local government in respect of monument protection is primarily to continuously monitor the situation of historic monuments and protected areas and to inform the

Historic Monument Protection Authority about any observations made and measures taken within their own sphere of competence.

d) Agencies with management authority and name and address of responsible contact person

Nature protection management of the nominated area is done by the Bükki National Park Directorate.

Responsible manager: József Duska

Address: H-3304, Eger, Sánc utca 6.

Phone: (36)-36-411-581 Fax: (36)-36-412-791

Responsibility for the archaeological finds is with the Cultural Heritage Directorate.

Responsible manager: Dénes B. Jankovich, Director

Address: H-1053 Budapest, Magyar u. 40.

Phone: (36-1) 266-0027 Fax: (36-1) 327-7702

Historic monument protection regarding national level values is ensured by the National Historic Monument Protection Authority

Responsible manager: Zoltán Cselovszki, President

Address: H-1014 Budapest, Táncsics M. u. 1.

Phone: (36-1) 3569-722 Fax: (36)-1-212-91-13

e) Level at which management is exercised (e.g. on property, regionally)

Regional-level management of nature protection in Hungary is exercised in accordance with the respective nature protection and other sectorial legislation. In Hungary, the obligation to manage the cultural heritage is the responsibility of the owner at all times. The professional and legal framework for management is

defined by the law on historic monument protection and building. The financial background for management of the state property is ensured by the income of the individual entities and the separate line in the budget, through the Treasury Asset Directorate. The by-laws of local governments related to value protection may grant financial support for the owners. In addition, the owners can apply for financial support to the foundations and separate state resources. These subsidies are in the form of one-time non-refundable grants or co-financing. The State Historic Monument Restoration Centre of the National Historic Monument Protection Authority provides design and professional restoration aid to solve the most demanding tasks.

f) Agreed plans related to property (e.g. regional, local plan, conservation plan, tourism development plan)

National Land Use Plan

The aim of the National Land Use Plan is to define a perspective for spatial structure within the country (location of the national transportation and utility networks, the system of urbanised, agricultural and nature preservation areas), to define the use of the land and conservation of natural resources as well as to ensure the framework conditions for development both from engineering and ecological aspects.

The task of the National Land Use Plan is:

- To balance the spatial structure
- To ensure a more consistent insertion into the global and European systems of communication
- To implement the regional land use quality conditions
- To provide area-related conditions for favourable development perspectives of settlements and groups of settlements

The Regional Structural Plan defines (in consideration of the load bearing capacity of the land) environmental protection, ecological conditions, the already established transport connections, the conditions for the national settlement structure, the obligations assumed within international co-operation programmes, the order of land use at regional level, the spatial structure of transport connections, and outlines the development trends of communities and provides guidelines for their development and/or change in their current development. Guidelines for regional land use are specified in the zonal regulations.

The National Land Use Plan – among others – declares the Tokaji Wine Region a priority area, an extremely sensitive area also in terms of cultural heritage. In this area, the historic monuments, buildings, bridges, archaeological sites, cityscapes, historic centres, villages, settlements, historical earthworks (dams, hills, earth fortresses) and the cultural and educational infrastructure embodied in the landscape features as well as the living human-ecological system of values shall be conserved by integrated protection.

There is a national interest in harmonised planning, land use and development of the cultural heritage areas. Hence the boundaries of the already defined priority areas have to be modified according to the cultural heritage areas and the same rules should apply for both.

The objective is to preserve the entire heritage as one single entity, be it cultural landscapes, archaeological properties, or historic monuments, i.e. to preserve all the heritage concentrated within the area proposed for inscription of the World Heritage List.

Regional Land Use Plans

The regional plan of Borsod-Abaúj-Zemplén county is being prepared. The plan is consistently following the rules and regulations of the National Land Use Plan, and detailing and making it even more accurate.

Local Land Use Plans

Local administration are obliged by the Act No. CXV of 1999 to renew their town plans and form decree on the protection of architectural values till the end of 2003. The local plans are obliged to consistently follow the measures of regional plans.

g) Sources and levels of finance

In Hungary sources of finance are as follows: Central state budget, Central Environmental Protection Fund Budget objective (according to the applications filed), Foreign grants: PHARE and Other EU grants.

Under Act No. LIV of 1997, the state-owned historic monuments and groups of buildings are maintained by the state. According to section 30 of Law, local governments shall ensure protection, maintenance and appropriate use of the monuments they own. Local governments may request financial aid from the central budget for priority or nationally important tasks.

Further opportunities of financing are funding competitions, applications for tax exemptions or low-interest loans.

h) Sources of expertise and training in conservation and management techniques

The human resources necessary for the theoretical support and practical implementation of management are available at the Bükki National Park Directorate. The directorate employs a supervisory team composed of ecologists, agrarian engineers, forestry engineers.

A number of national and regional Hungarian institutions are involved in the inventarisation, registration, documentation and restoration of the cultural heritage. These are: the Archaeological Institute of the Hungarian Academy of Science, the Ethnographic Institute of the Hungarian Academy of Science, the

History of Arts Research Group of the Hungarian Academy of Science. Ethnographic Museum, National Historic Monument Protection Authority, Cultural Heritage Directorate, The Miskolc Herman Ottó Museum.

These institutions have the necessary staff of archaeologists, ethnographers and art historians. The restoration expert personnel of the National Historic Monument Protection Authority is also available.

Training of archaeologists, ethnographers, art historians and architects is conducted in several Hungarian universities, professional restoration personnel is trained at the Hungarian High School of Fine Arts. There is a proper network of expertise and training in Hungary to ensure the supply of appropriately qualified staff in all respects.

i) Visitor facilities and statistics

Important events in Tokaji Wine Region				
Event	Place	Time	Visitors	Features
Grape harvest days	Settlements in Tokaji Wine Region : Mád, Tállya, Bodrogkeresztúr, in the centre of Erdőberénye, the main programme is in the main street of Tokaj	End of September, beginning of October 1-2 days	30 000 people	Traditional grape harvest parade, local wine contest, wine tents, open market, tools of viticulture, traditional song and folk dance groups
Cultural Days in Zemplén	Settlements of Zemplén , Sárospatak	August one week	10 000 people	Concerts of classical music, cultural events, ball and dinner
Farmers' Days in Hegyalja	Szerencs city centre	The weekend before Whitsuntide 3 days	25 000 people	Wine contest of Tokaji Wine Region, vocational conference, the presentation of the values of the area, professional market of 150 exhibitors
Tarcal Fair	Sports ground in Tarcal , Kopasz hegy of Tokaj	End of July 2 days	5-6000 people	Demonstration plays of the Árpád Age: horsemen and bow-men, recalling of historical wine-routes
Children's and Gypsy Dance Festival	The Cultural Centre of Sátorajjájhely	August 2 days	5-6000 people	Hungarian and foreign groups

j) Property management plan and statement of objectives

The concerning acts and regulations are closed in the Annex. The management plans of protected nature areas – covering a minority of the nominated property - are under renewal.

The management of cultural property is controlled by the respective national, regional and local plans.

k) Staffing levels (professional, technical, maintenance)

In Hungary general organising principle is that the owner is responsible for the management and maintenance of the property. The owner can get professional help from several highly educated experts of National professional bodies, especially from the Directorate of Bükk National Park, Monument Protection Authority, and several NGO-s as wine communities, wine councils etc.

V. Factors affecting the property

a) Development pressures (e.g. encroachment, adaptation, agriculture, mining)

In Hungary, due to legislation on nature conservation and environmental protection and acts on monuments, vineyards and wine production no development is possible in the protected areas in the Tokaji Wine Region and in the buffer zone that could be harmful from nature conservation and especially from viticulture and wine production point of view.

b) Environmental pressures (e.g. pollution, climate change)

No significant pollution can be expected. Pollution transported by air is decreased since the heavy industry plants essentially decreased their production after 1990 in the region. Farther development of canalisation and sewage treatment is desirable.

c) Natural disasters and preparedness (earthquakes, floods, fires, etc.)

No true natural disasters endanger the area of the Tokaji Wine Region. Drought can damage the agriculture of the area. Danger of flood can menace the settlements along the riverside of Bodrog and Tisza, on the fringe of the protected area. Flood protection of these settlements is adequate, i.e. no disasters are anticipated there.

d) Visitor/tourism pressures

One may say that tourism has no effects endangering the natural property and cultural values of Tokaji Wine Region.

e) Number of inhabitants within property, buffer zone

Property: 12.947

Buffer zone: 72.380

Altogether 85.327

VI. Monitoring

a) Key indicators for measuring state of conservation

The most important current and potential indicators for measuring the protection and state of conservation of the natural property are as follows:

Current: (mainly in the protected nature areas)

- vegetation and biotope pattern
- population size of characteristic species for individual biotope types and relative frequency

Potential:

- abundance and dominance values of weeds and invasive species

Monitoring of the cultural property is ensured by the institutions referred to under sections IV.d and VI.k.

b) Administrative arrangements for monitoring property

The National Monitoring Program is under development, it will cover all the sectors of spatial development, national and regional land use. The Secretary of Hungarian National Committee of World Heritage monitors annually every each Hungarian property listed by Unesco World Heritage Committee.

c) Results of previous reporting exercises

In the recent years, in the wake of privatisation, most of the new efforts have aimed at the traditional planting density instead of types adjusted to accommodate machinery plantations in vineyards. There were no significant change in the number of protected cultural objects. Important tendency is the development of local protecting system of architectural values. One can so realise the sign of appearance of subsidiary in the preservation of cultural heritage.

VII. Documentation

a) Illustrations (see Annex)

b) Copies of management plans, extracts of relevant acts (see Annex)

c) Bibliography

General and comprehensive works

Bél M., 1735-1742 – Notitia Hungaria novae historico geographica I-IV. Budapest, V. Budapest, 1892.

Bombardi M., 1718. – Topographia magni regni Hungariae, Viennae

Fényes E., 1851 – Magyarország geographiai szótára I-IV. Pesten

Hunfalvy J.-Rohbock A., 1860 – Magyarország és Erdély eredeti képekben II. Darmstadt

Korabinszky J. M., 1786 – Geographisches – Historisches und Producten Lexikon von Ungarn

Marosi S.-Somogyi S., szerk.: 1990 – Magyarország kistájainak katasztere. Budapest

Paget J., 1839 – Hungary and Transylvania, with remarks on their condition, social, political and economical, London

Prinz Gy.-Cholnoky J. – gr. Teleki-Bartucz L., é.n. Magyar föld magyar faj I. Magyarország tájrajza. Budapest

Rudolf trónörökös szerk.: 1896 – Az Osztárk-Magyar Monarchia írásban és képen. Magyarország, IV. köt. Budapest

Vályi A., 1796 – Magyarország leírása. Buda

History

Csánki D., 1890-1913 – Magyarország történelmi földrajza a Hunyadiak korában. I-III., V. Budapest

Györffy Gy., - Az Árpád-kori Magyarország történet földrajza. Budapest

Hóman B. – Szekfű Gy., 1935 – Magyar történet I-V. Budapest

Marczali H., 1911 – Magyarország története. Budapest

Pach Zsgmond P. szerk.: 1976-1989 – Magyarország története tíz kötetben. Budapest

Monographs of counties

Bél M., 1732 – Zempleniensis Comitatus Notitia Historica, Kézirat, Országos Széchényi Könyvtár Kézirattára, Fol. Lat. 274
Borovszky Samu szerk.: Abaúj-Torna vármegye. Budapest
Borovszky Samu szerk.: Zemplén vármegye. Budapest
Mohl J. – Laszgallner A. G., 1928 – Das Tokayer Weingebirge und dessen Umgebungen genannt: Hegyallya, Kassa
Molnár A., 1799 – Tekintetes Nemzetes Zemplén vármegye leírása, Kézirat, Az Országos Széchényi Könyvtár Kézirattára, Quart. Hung. 61.
Varga Gáborné szerk.: 1970 – Borsod-Abaúj-Zemplén megye története és legújabb kori adattára. Miskolc

Tokaji Wine Region

Alkonyi L., 2000 – Tokaj. A szabadság bora...
Bencsik J., 1991 – Tokaj. Tokaj
Csorba P., 1995 – Tolaj-hegyalja tájökölógiai szerkezetének és geomorfológiai adottságainak összehasonlítása. Földrajzi Értesítő, XLIV. évf. 1-2.
Dékány T., 1997/1-2. – Tokaj-hegyalja nekirugaszkodik. Falu Város Régió
Fucker A., 1751 – Tokainum Illustratum, Kézirat, Az Országos Széchényi Könyvtár Kézirattára, Quart. Lat. 1984.
Gyulai I., 1984 – Védett természeti értékek Borsod-Abaúj-Zemplén megyében. Miskolc
Halmai L., szerk.: 1997 – Borút 97. Csobogó magazin I. évf. 3. sz.
Kardos J., 1983 – A szőlő- és bortermelés integrációja Tokaj-hegyalján. Budapest, kézirat
Laposa J., 1996 – Föld alatti mennyország – Rákóczi pince. Borbarát magazin I. évf. 1. sz.
Pataky S. szerk.: 1996 – Tarcál. Tarcál
Pataky S. 1997 – Bortúra Tokaj-hegyalján. Tarcál
Pap M., 1983 – Tokaj
Szabó J., 1984 – Tokaj-hegyaljai album. Budapest
Szabolcs A., 1991 – Tokaj-hegyaljai kalendárium. Miskolc
Tamaskó Ö. szerk.: 1958 – Zempléni hegység. Budapest
Tardy J. 1996 – Magyarországi települések védett természeti értékei. Budapest
Tardy L. 1963 – A tokaji Orosz Borvásárló Bizottság története (1733-1798) Sárospatak

Architecture and monuments

- Ághné Korompay K., 1989 – Tokaj a XVIII.-XIX. század fordulóján. Archív tervek üzenete a múltból a holnapot építő mának. In.: Tokaj és Hegyalja I. Szerk.: Bencsik J. és Szappanos Erzsébet, Miskolc
- Borbély A., 1933 – Adatok Tokaj vára helytörténetéhez, Debreceni Szemle, 11. szám
- Csorba Cs., 1989 – Tokaj várának története, in.: Tokaj és Hegyalja I. Szerk.: Bencsik J. és Szappanos Erzsébet, Miskolc
- Cs. Dobrovits S., 1983 – Építkezés a XVIII. századi Magyarországon (Az uradalmak építészet), Budapest
- Dobrik szerk.: 1987 – Műemlékek Borsod-Abaúj-Zemplén megyében. Miskolc
- Ember A., 1987 – Debreczeni Ember András és Marton János leírásai Tokaj-Hegyalja és Zemplén településeiről. Szerk.: Pap Miklós, Miskolc
- Genthon I., 1959 – Magyarország művészeti emlékei II. Budapest
- Győrffy K., 1991 – Kultúra és életforma a XVIII. századi Magyarországon (Idegen utazók megfigyelései), Budapest
- Hodinka A., 1989 – A tokaji görög katolikus parochia történetének forrásai. In.: Tokaj és Hegyalja I. Szerk.: Bencsik J. és Szakál J.-né, Miskolc
- Hrenkó P., 1978 – Lucas Geörg Ssicha hadmérnök tokaji várképei nyomában, Geodézia és Kartográfia, 30. évf. 5. szám
- Olajos Cs., 1990 – A tarcali koronauradalom építészeti emlékei. A Herman Ottó Múzeum Évkönyve
- Ribáry Z. – Joó T., 1964 – A tokaji pálos kolostor nyomában. A Herman Ottó Múzeum Közleményei, 6.
- Soós E., 1914 – A tokaji vár történeti hadi- és műleírása, Adalékok Zemplén-vármegye történetéhez, XIX.
- Spech L., 1823. Tisza-Tokaj városának rövid leírása, Tudományos Gyűjtemény, IV.
- Magyarország műemlékjegyzéke 1990 – I. Budapest
- Szabadsfalvy I., Cseri M. szerk.: 1992 – Borsod-Abaúj-Zemplén megye képes műemlékjegyzéke. Miskolc
- Szabó J., 1989 – Szerzetesrendek, kegyestánítórendi-iskola Tokajban. In.: Tokaj és Hegyalja I. Szerk.: Bencsik J. és Szappanos E., Miskolc

Ethnography and history of economy

- Bakos J., 1947 – Bodroghöz, Hegyalja és Hegyköz táj- és néprajzi irodalma. I. rész. Sárospatak
- Bakos J., 1950 – A pataki múlt hétköznapijai. Adalékok Sárospatak gazdaságtörténelméhez. Sárospatak
- Bakos J., 1957 – Tokaj-hegyalja és bortermelése néprajzi, hely-, gazdaság- és művelődéstörténeti irodalma. Sárospatak
- Bencsik J., 1988 – Tokaj város gabonafelvásárlása a XVIII. század végén. In.: Hegyaljai mezővárosok történeti néprajza, szerk.: Bencsik J. és Viga Gy., Miskolc

Bencsik J., 1990 – Tisza-Tokaj mezőváros túlnépesedése a XVIII. század második felében. In.: Tokaj és Hegyalja II. Szerk.: Bencsik J. és Szakál J.-né, Miskolc
Bencsik J. 1993/a – Paraszt és mezővárosi kultúra a XVIII.-XX. században, Miskolc-Tokaj
Bencsik J. 1994/b – Tokaj társadalma a tárgyak tükrében (1774-1849), Sátoraljaújhely
Fügedi M., 1997 – Borsod-Abaúj-Zemplén megye népművészete
Makkai L., 1954 – I. Rákóczi György birtokainak gazdasági iratai (1631-1648). Budapest
Makkai L., 1966 – Jobbágytelek és parasztgazdaság az örökös jobbágyság kialakulásának korszakában. Tanulmányok Zemplén megye XV-XVIII. századi agrártörténetéből. Budapest
Orosz I., 1960 – A hegyaljai mezővárosok társadalma a XVII. században. Budapest
Orosz I., 1984 – Településrend és a kertek típusai Tokaj-Hegyalja mezővárosaiban a XVII.-XVIII. században Ethnographia, XCV.

d) Addresses where inventory, records and archive are held

Magyar Nemzeti Múzeum
(Hungarian National Museum)
1088 Budapest, Múzeum körút 14-16

Magyar Természettudományi Múzeum Állat- és Növénytár
(Hungarian Natural Science Museum Animal and Plant Archive)
1088 Budapest, Baross utca 13.

Magyar Mezőgazdasági Múzeum
(Hungarian Museum of Agriculture)
1146 Budapest, Olof Palme sétány

Magyar Országos Levéltár
(Hungarian State Archives)
1014 Budapest, Bécsi kapu tér 2/4 (Historical maps)

Országos Széchenyi Könyvtár Térképtára
(Map Archive of the National Széchenyi Library)
Budapest Budavári Palota, F szárny

Hadtörténeti Intézet és Múzeum Térképtára
(Map Archive of the Military History Institute and Museum)
1014 Budapest, Kapisztrán tér 2/4

Borsod-Abaúj-Zemplén Megyei Múzeumi Igazgatóság
2529 Miskolc, Görgey Artúr út 28.

Borsod-Abaúj-Zemplén megyei Levéltár
2525 Miskolc, Fazekas utca 2.

Földmérési Intézet (FÖMI)
(Land Survey Institute)
1149 Budapest, Bosnyák tér 5.

Magyar Honvédség Térképészeti Hivatala
(Mapping Institute of the Hungarian Armed Forces)
Budapest, Szilágyi Erzsébet fasor 7-9.

MTI – Magyar Távirati Iroda
H-1016 Budapest, Naphegy tér 8.

OmvH – Országos Műemlékvédelmi Hivatal
H-1014 Budapest, Táncsics M. utca 1.

VÁTI – Magyar Regionális Fejlesztési és Urbanisztikai Közhasznú Társaság
H-1016 Budapest, Gellérthegy utca 30-32.

written and compiled on the basis of various contributions by

Frankó Ákos and Dr. Máté Zsolt

with special thanks to László Alkonyi for authorising the use of the text of his book “Tokaj the Wine of Freedom” and to Tibor Dékány who is the author of most of the photos

Budapest, in December of 2000

Signature on behalf of the
Republic of Hungary

Annex 1

Annex 1e - Maps and plans

1. map: Geographical situation	1:500.000
2. map: Topographical map of Core Area of the Property	1:75.000
3. map: Property: Core Area and Buffer zone	1:250.000
4. map: Land use	1:250.000
5. map: Nature and landscape protection	1:250.000
6. map: Cultural heritage	1:250.000
7. map: City Map of Sátoraljaújhely, with the sign of the nominated Ungvári Cellar	1:15.000
8. map: Entrances of Ungvári Cellar Sátoraljaújhely	1:1000
9. map: Plan of Ungvári Cellar Sátoraljaújhely	1:1000
10.map: City Map of Sárospatak, with the sign of nominated Rákóczi Cellar	1:15.000
11.map: Plan of Rákóczi Cellar Sárospatak	1:750

World Heritage, Cultural Landscape of Tokaj Wine Region

Republic of Hungary

List of pictures

01. Satellite view of Tokaji Wine Region
02. The view of Tarczal from vineyards
03. The Wine Region
04. Winter in the vineyard
05. Part of a street in Tarczal
06. The “Kings’ Court” in Tarczal, from the 16th century
07. The process of grapes becoming aszú
08. Sessile oak forest in the Zemplén mountain range
09. Cellar in Sátoraljaújhely
10. View of Tokaj
11. Synagogue and the college of rabbinical studies in Mád, from the late 18th century
12. One puttony of aszú
13. Orthodox church in Tokaj, end of 18th century
14. The entrance of the Dessewffy Mansion in Tokaj, around 1700
15. The SÁrgaborház (Yellow Wine House) in Mád in the vineyard
16. Disznókő in Mád in winter
17. Grape harvest in the Royal Parcel in Mád
18. Settlement of Tokaj from the Bodrog
19. Vine harvest in Tállya
20. Mansion in Tállya, from the 18th century
21. Plantation of wines in Tokaj
22. View of Bodrogkeresztúr
23. View of Tokaj from Bodrogkeresztúr
24. Wine plantation in Bodrogkeresztúr
25. Wine plantation along the Bodrog
26. Wine plantation in autumn
27. Jewish cemetery in Bodrogkeresztúr
28. Cluster of grapes becoming aszú
29. The Ungvár Cellar in Sátoraljaújhely
30. The Pogácsás Cellar in Tolcsva
31. Peasant cottage
32. The Rákóczi Castle in Sárospatak, from the 16th century
33. Entrance of a cellar in Tolcsva
34. View of Erdőberénye in winter
35. The Rákóczi Castle in Sárospatak, from the 16th century
36. Chain of cellars in Erdőberénye in winter
37. Entrance of a cellar made of carved stone in Erdőberénye
38. Chain of cellars in Erdőberénye in summer
39. Wine plantation in Mád
40. Hooper in work
41. Bottles of Tokaji
42. The Hall of the Knights in the Rákóczi Cellar in Tokaj
43. The favourite “place for eating bacon” of Prince Rákóczi in Sárospatak
44. Golden plated silver work decorating the satchel of a Hungarian conqueror in the 9th century, found in Tarczal
45. Wax seal of Tarczal market-town from 1612



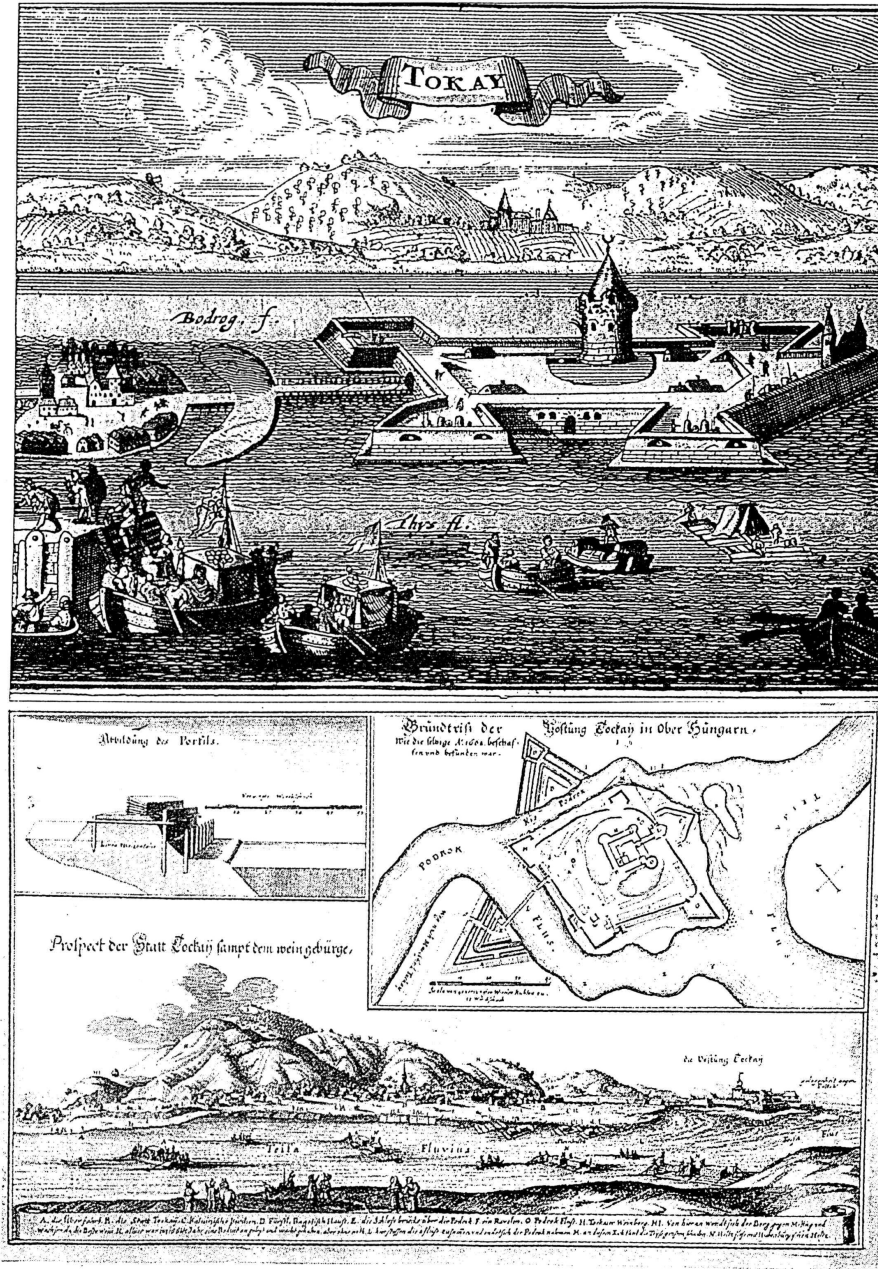

Panorama of Tokaj – 17th century



Annex 1e 1. map: WORLD HERITAGE - TOKAJI WINE REGION

geographical situation

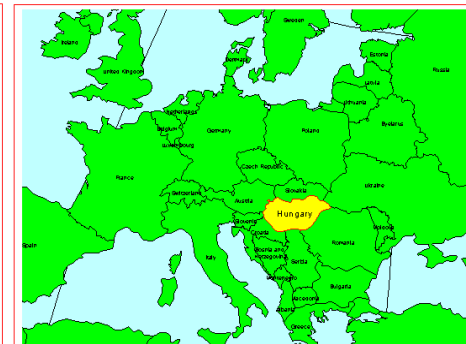

OVERVIEW of Europe

Legend

-  location of Tokaji Wine Region
-  main cities and capitals
-  Hungary
-  neighbour countries
-  seas and oceans

Scalebar



Scale

1 : 500.000

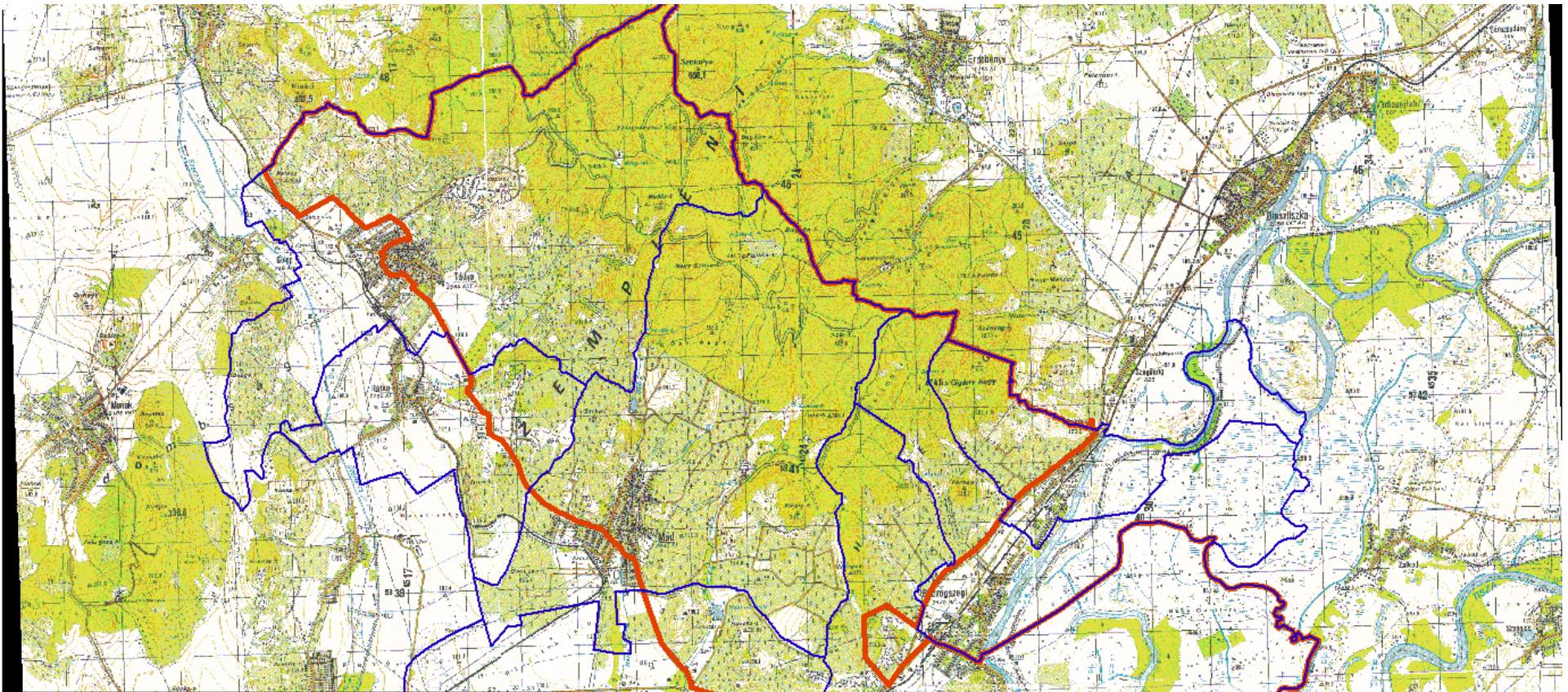

Projection: HUNGARIAN NATIONAL PROJECTION (EOV)

edited by Sándor Bardóczi



Annex 1e
 2. map: WORLD HERITAGE - TOKAJI WINE REGION
 Topographical map of Core Area of the Property

Legend

-  Core Area
-  Administrative Boundary

Scale

1:75,000

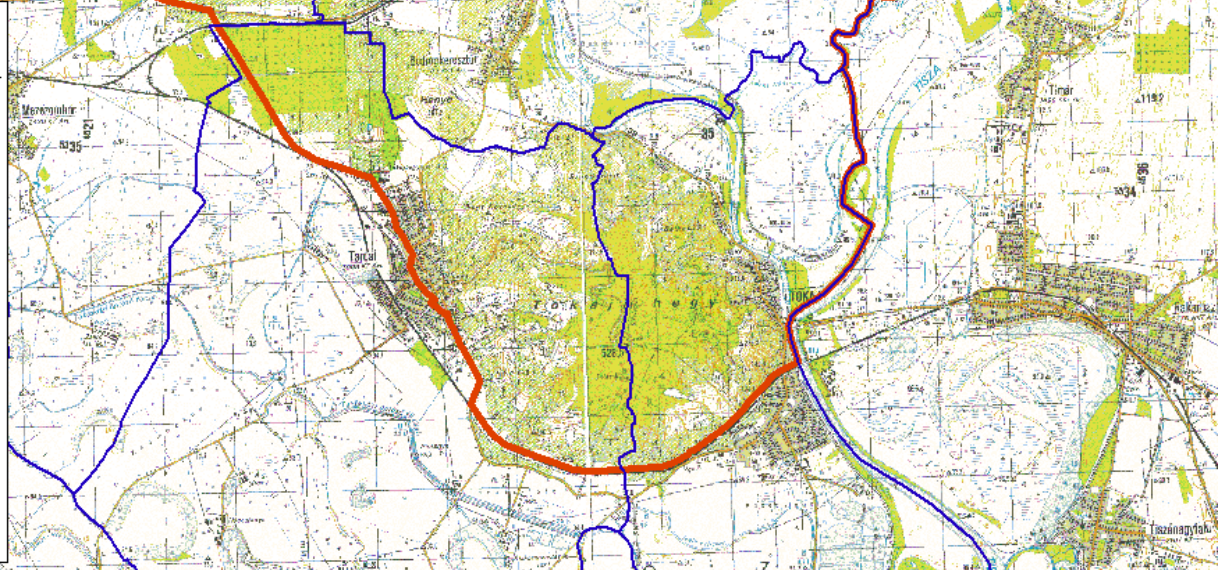
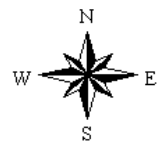
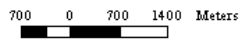

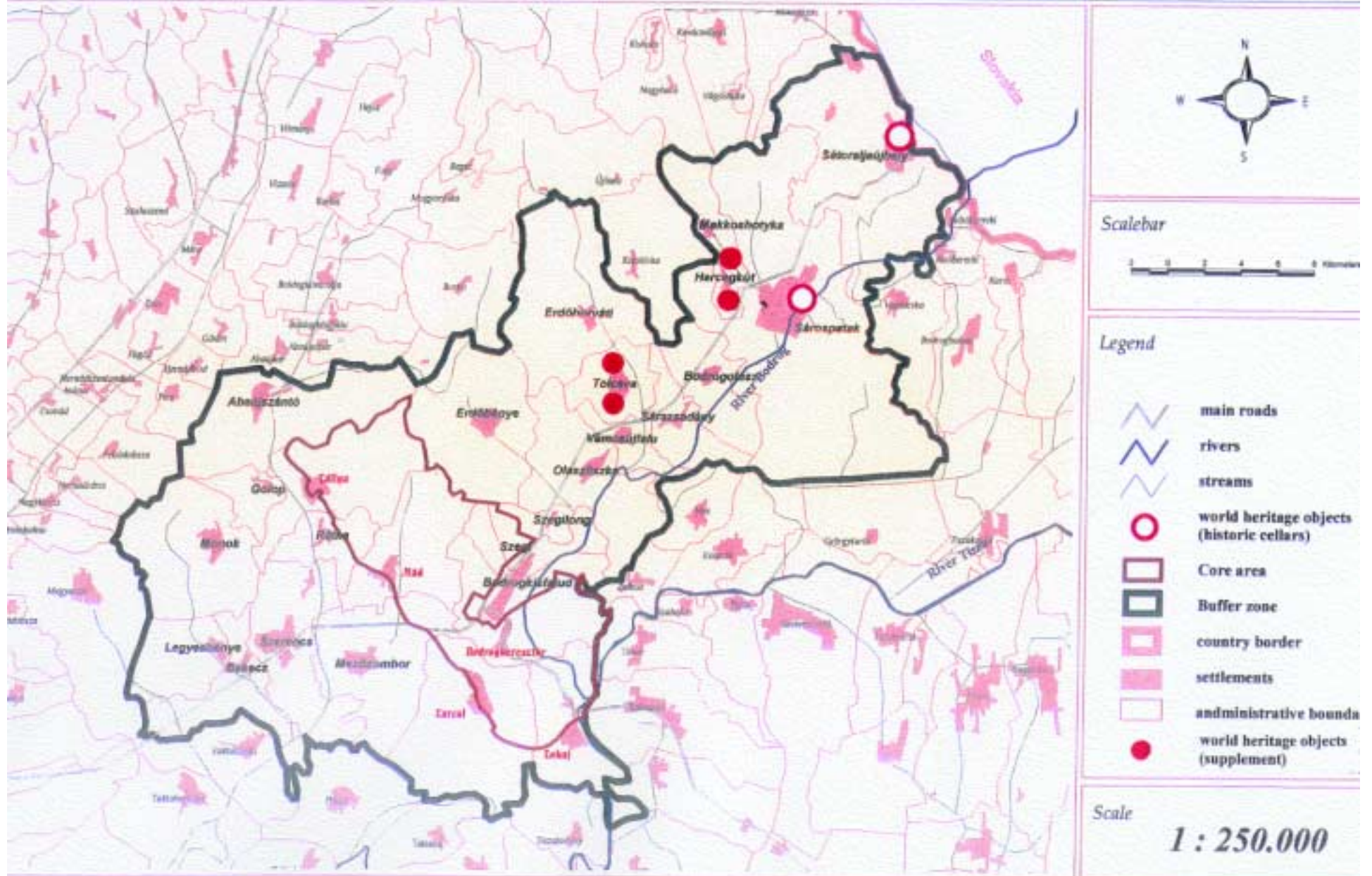

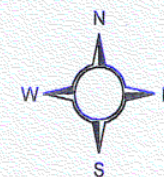
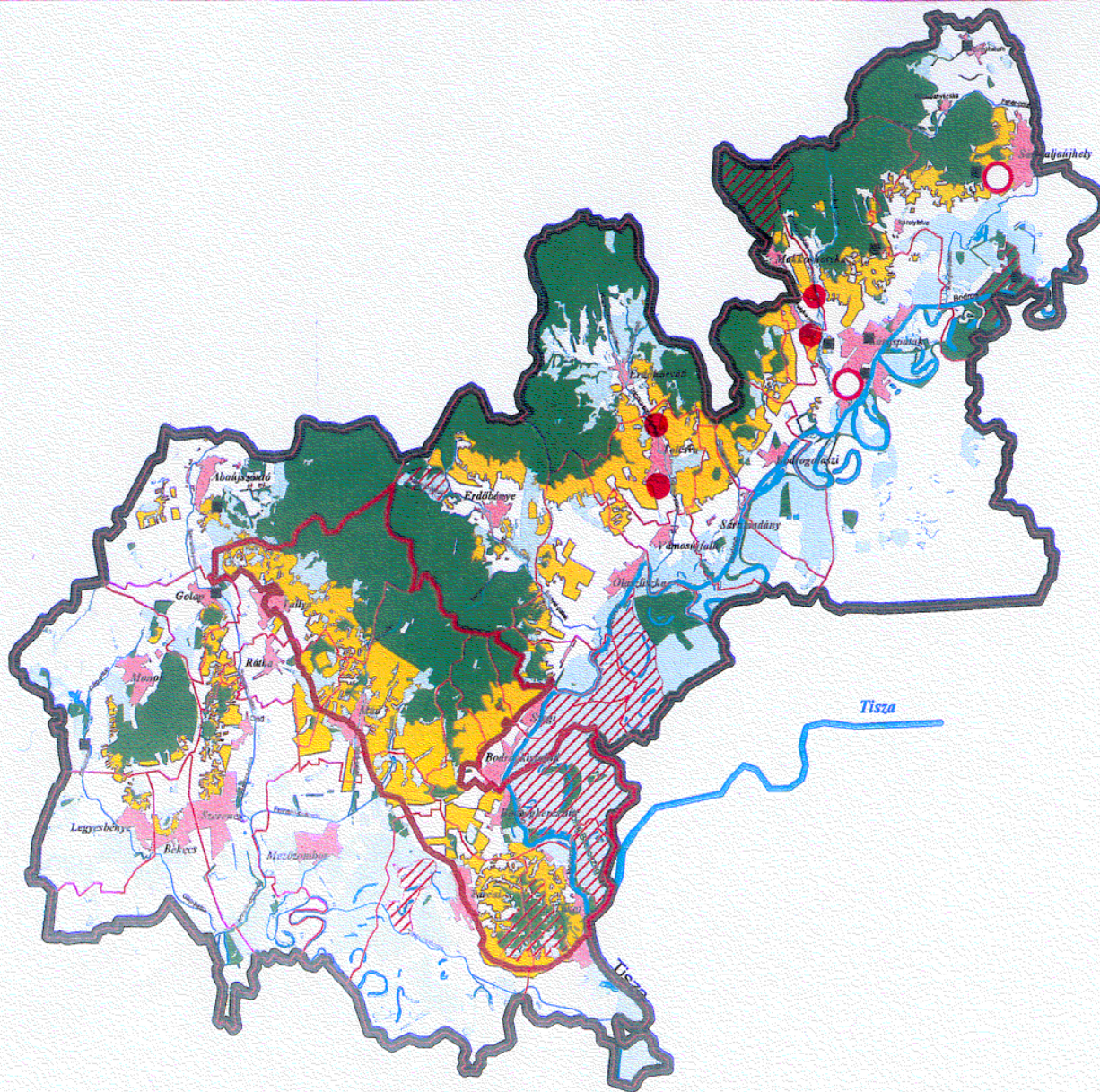

Legend

- world heritage objects (historic cellars)
- administrative boundary
- core area
- buffer zone
- nature protection area
- world heritage objects – supplement
- main roads
- railways
- rivers
- streams
- residential areas
- classified vineyards
- national reservation area
- greenway elements**
 - forests
 - meadows and pastures
 - backwaters and lakes

Scale

1 : 250.000

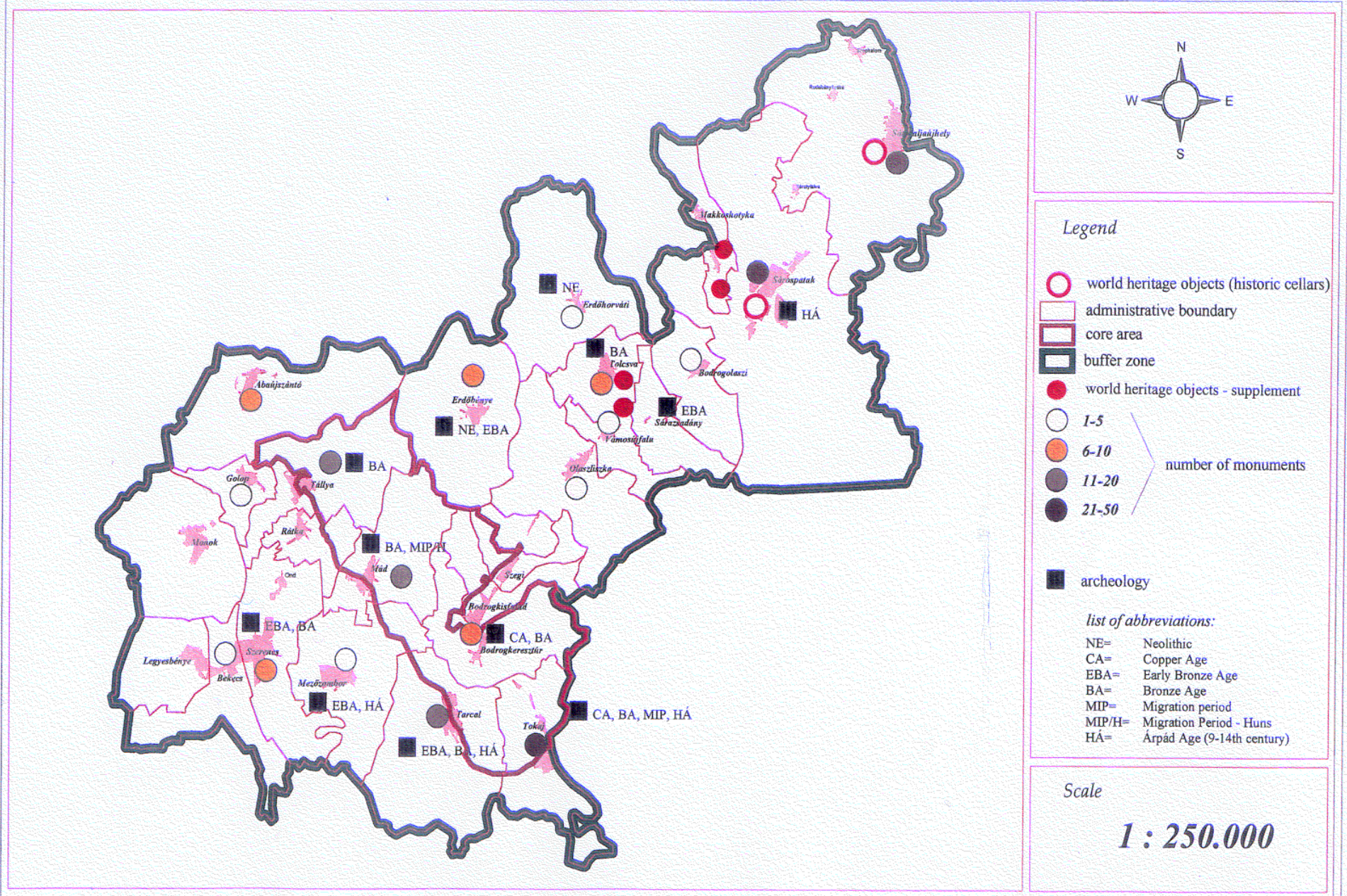

Projection: HUNGARIAN NATIONAL PROJECTION (EOV)

Scale

1 : 250.000

edited by Sándor Bardóczi

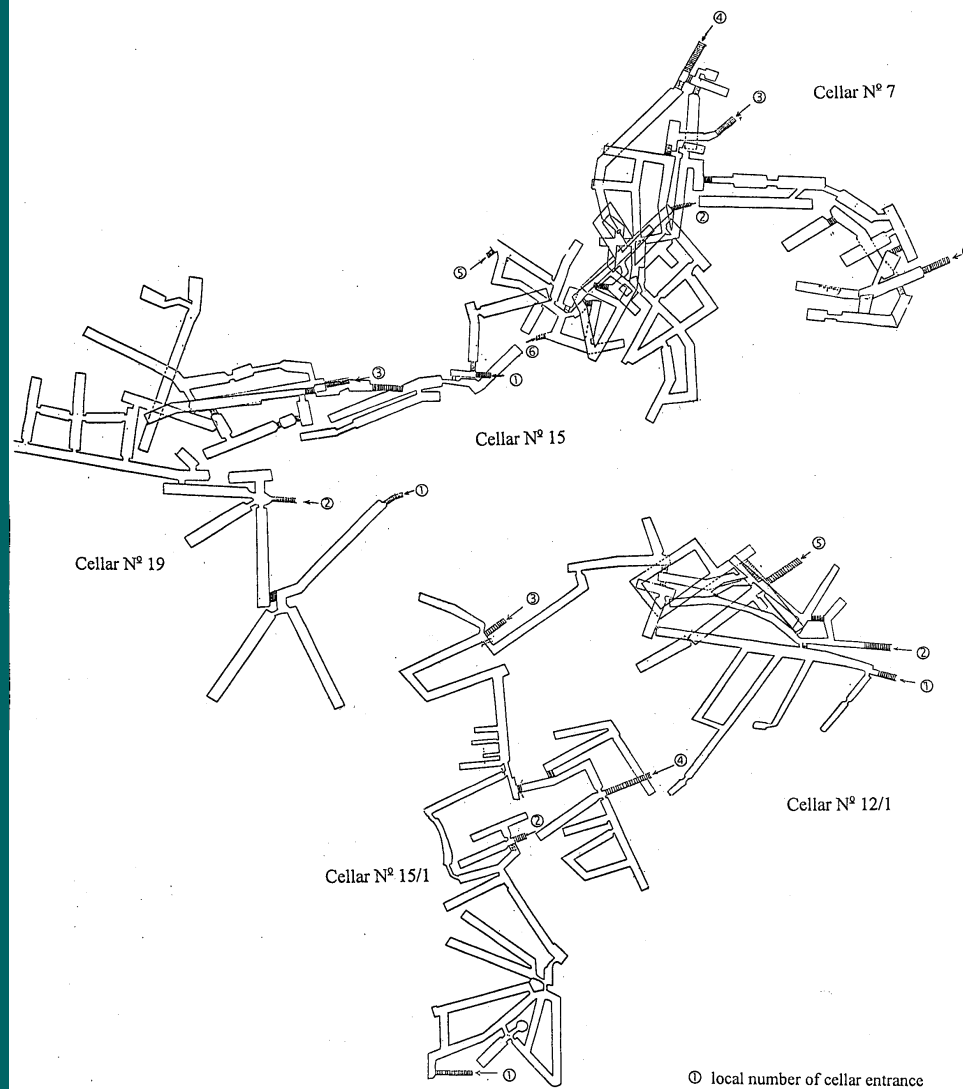

Annex 1 e - WORLD HERITAGE TOKAJI WINE REGION

Map 9. - Plan of Ungvári Cellar 1:1000

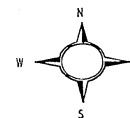



Ungvári Cellar – Sátoraljújhely



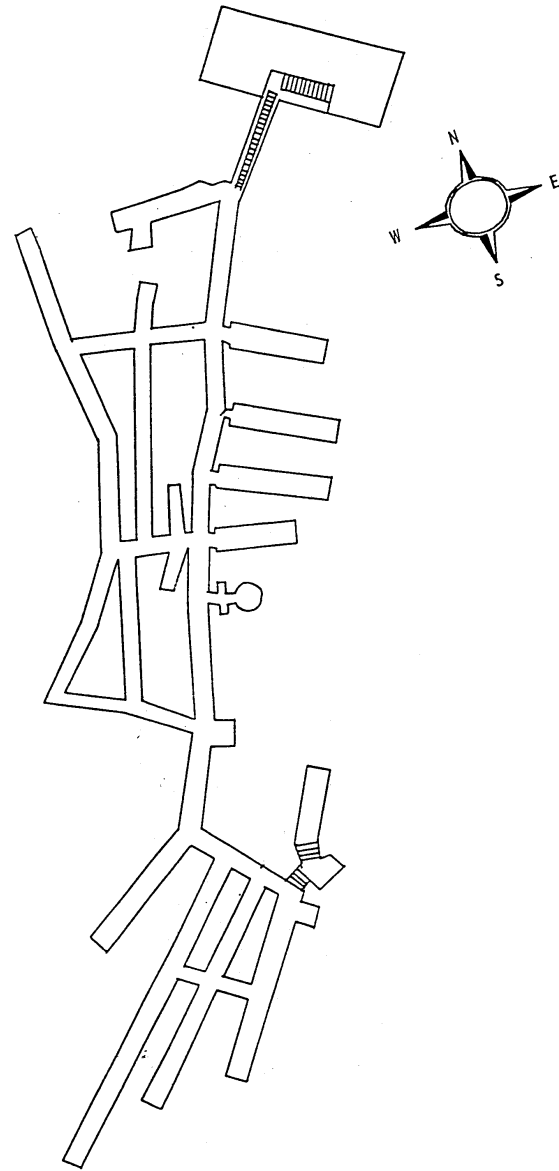

Annex 1e – World Heritage Tokaji Wine Region
Map 11. – Plan of Rákóczi Cellar Sárospatak 1:750



Rákóczi Cellar – Sárospatak

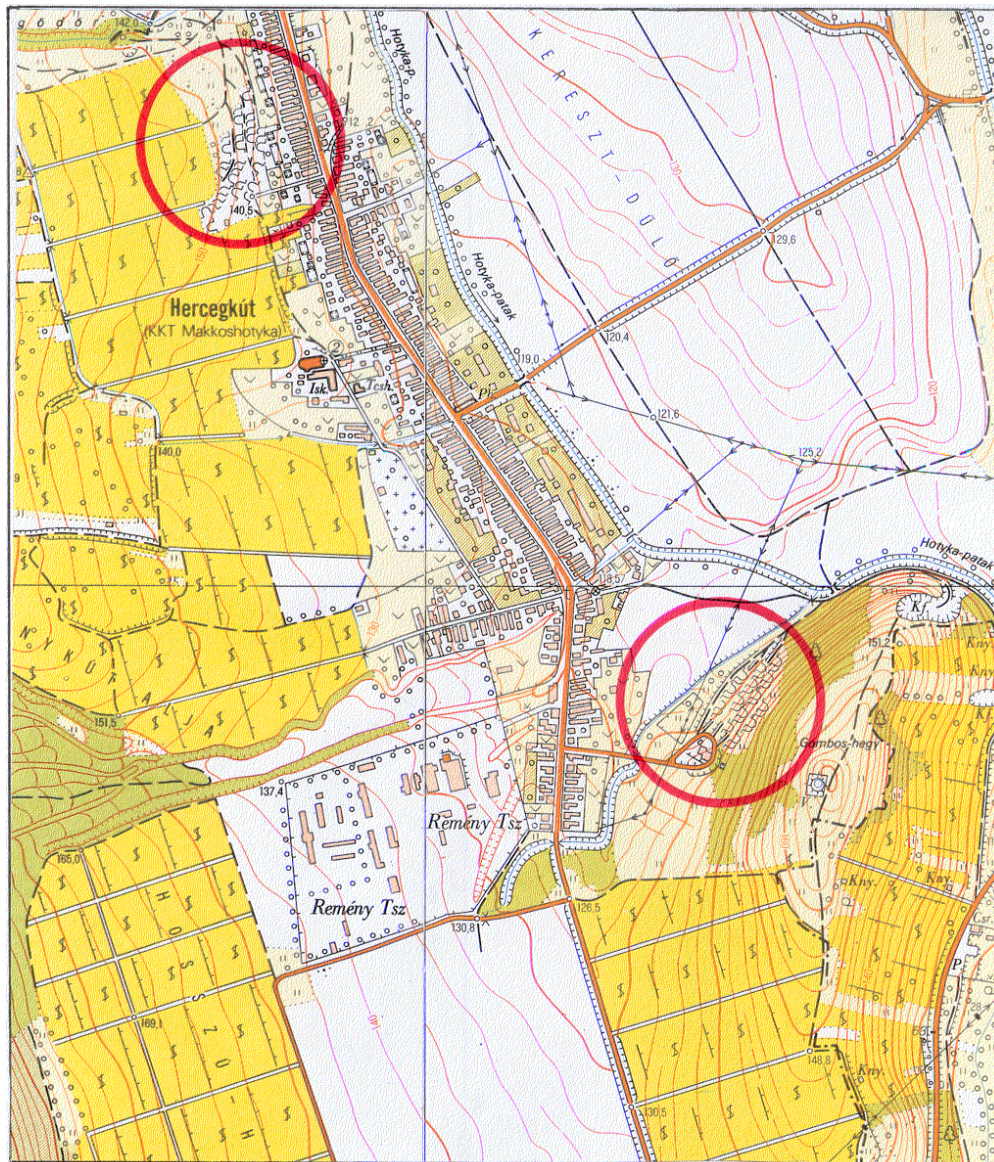

Annex 1 e –

Supplement

WORLD HERITAGE TOKAJI WINE REGION

Map 13. - Village map of Hercegekút

1:10 000

with the signs of Kóporosi and Gomboshegyi cellars

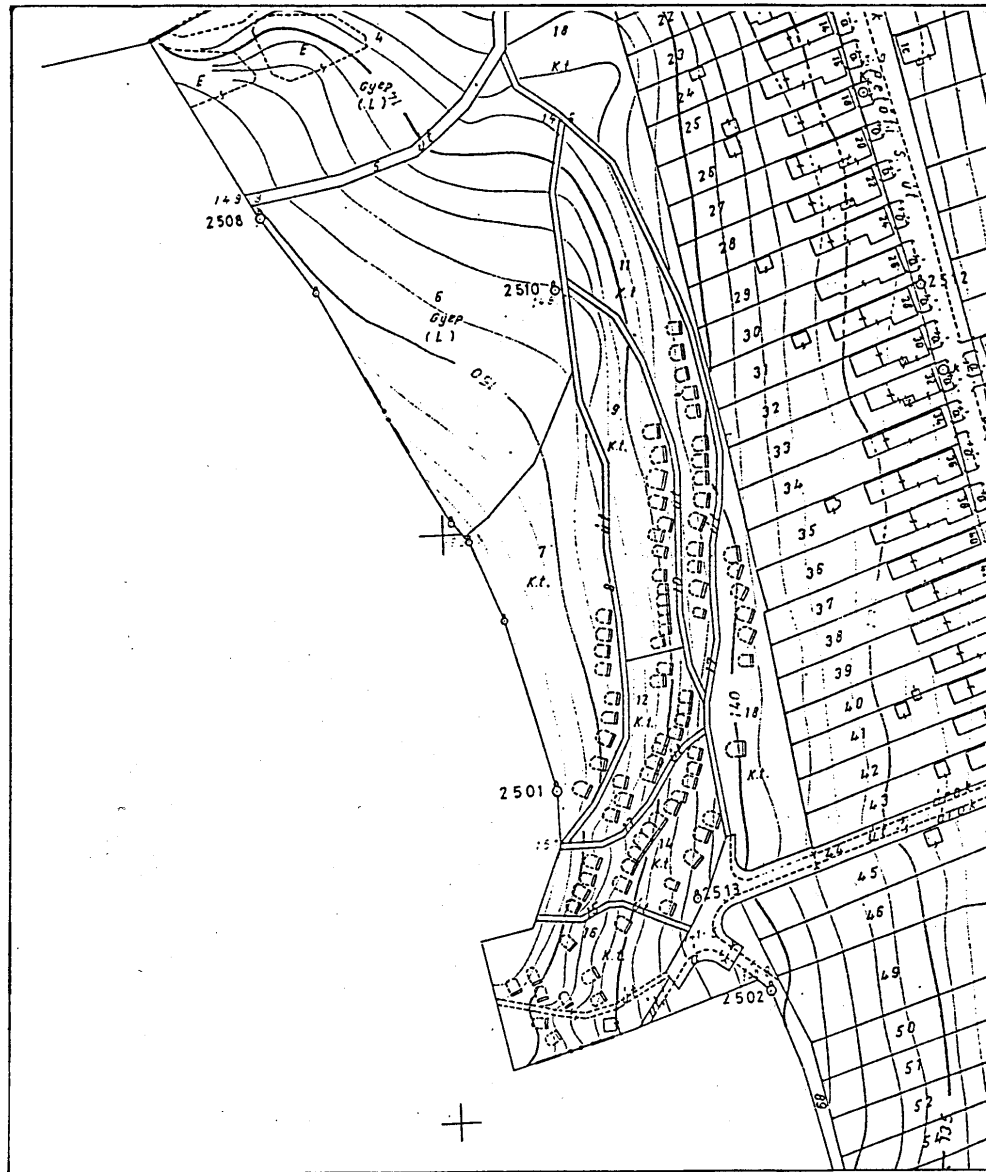

Annex 1 e –
 Supplement **WORLD HERITAGE TOKAJI WINE REGION**
 Map 14. - Site map of Hercegekút Kőporosi cellars 1:2 000

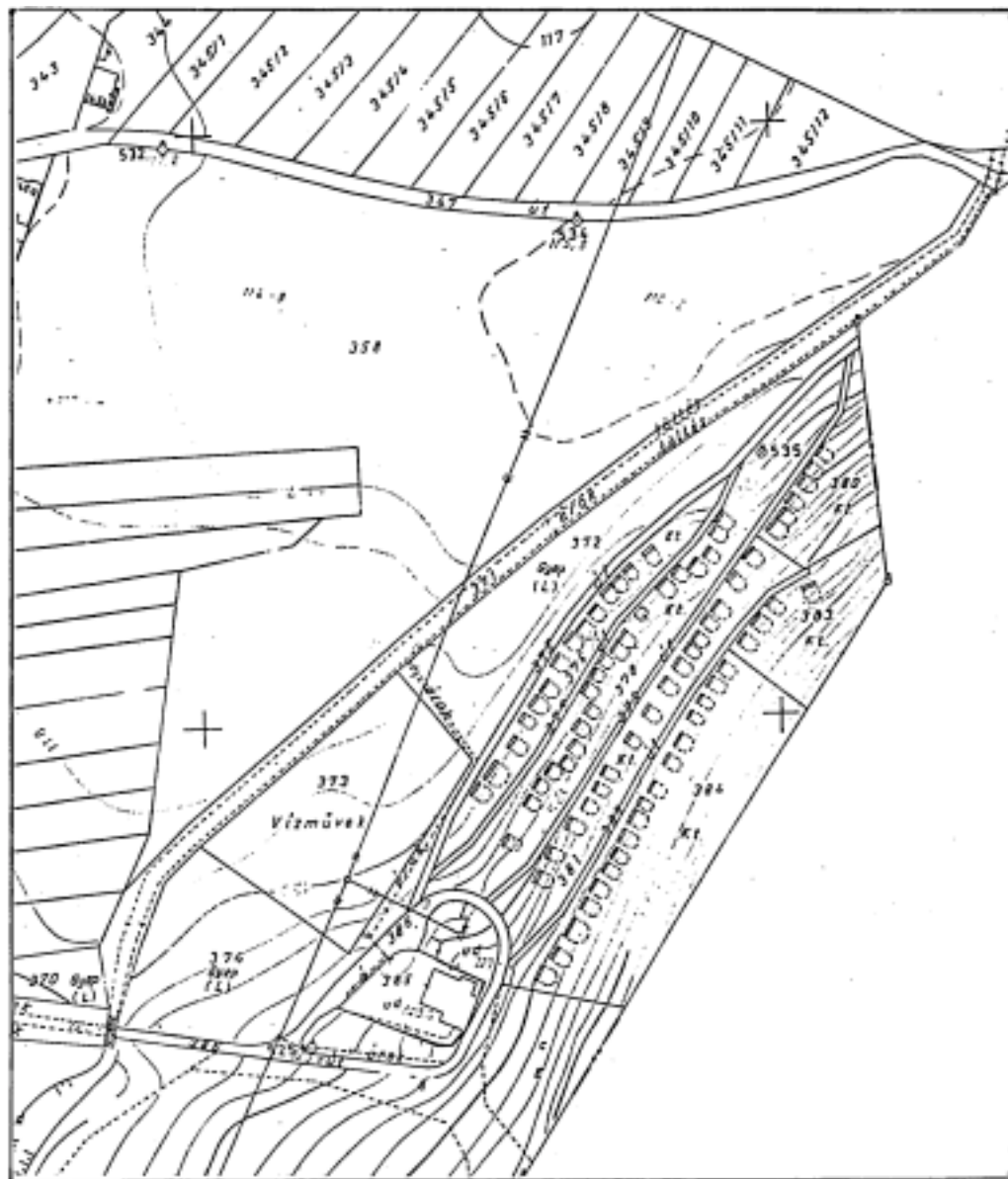

Annex 1 e -
 Supplement **WORLD HERITAGE TOKAJI WINE REGION**
 Map 15. - Site map of Hercegkút Gomboshegyi cellars 1:2 000

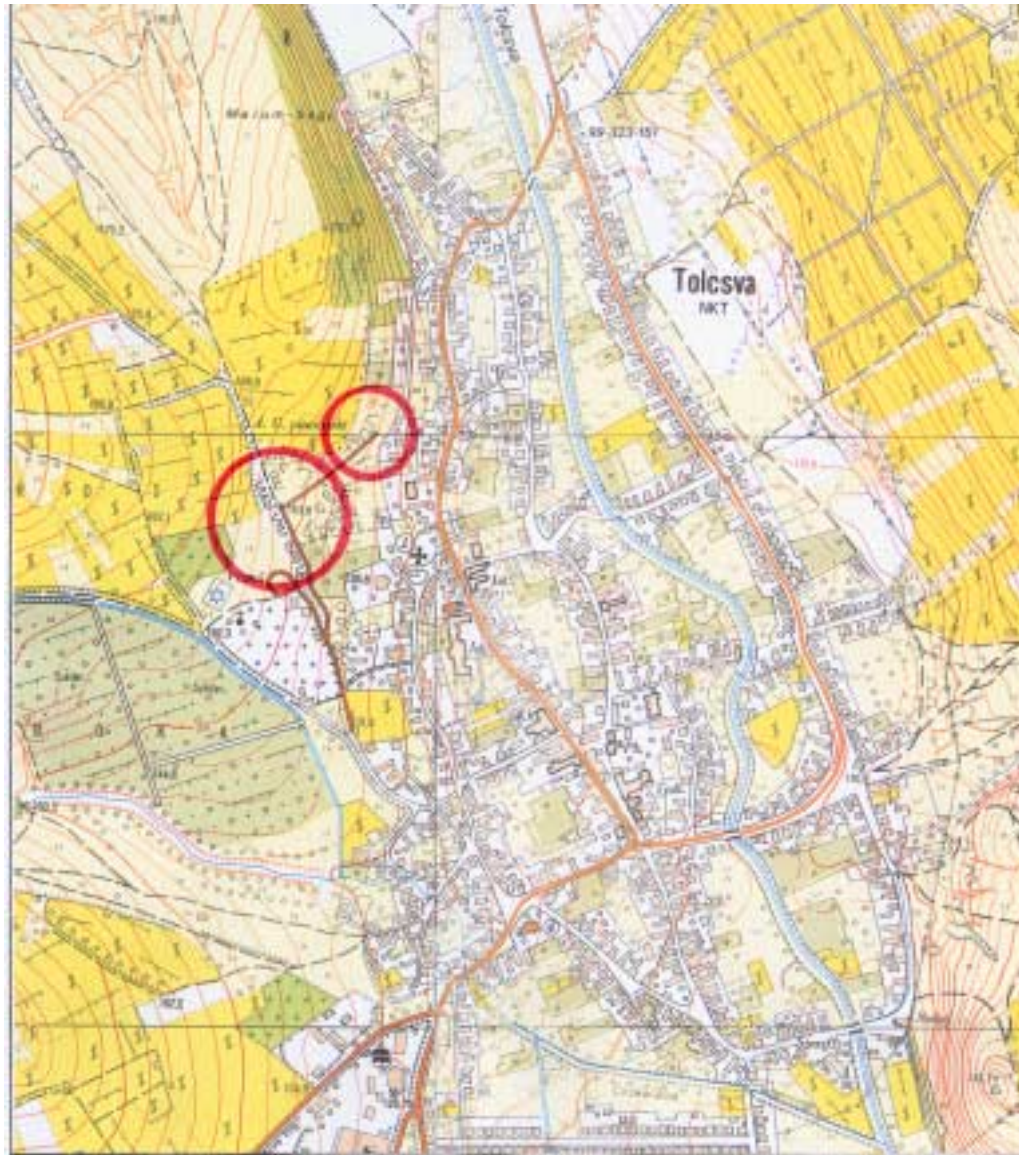

Annex 1 e -

Supplement

Map 16. -

WORLD HERITAGE TOKAJI WINE REGION

Village map of Tokcsva

1:10 000

with the signs of Oremus cellars and Wine Museum

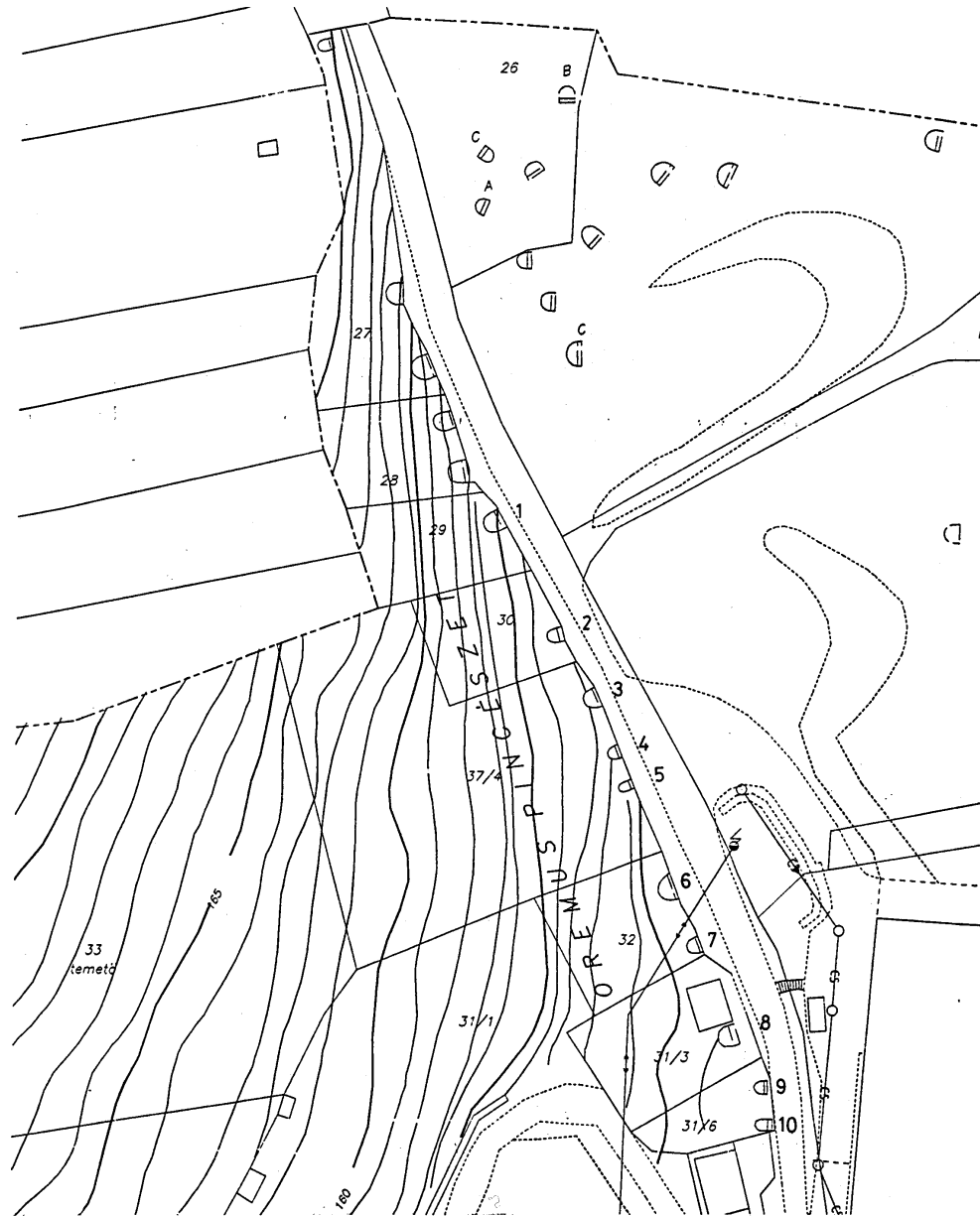

Annex 1 e –
 Supplement **WORLD HERITAGE TOKAJI WINE REGION**
 Map 17. - Site map of Tolcsva Oremus cellars 1:2.000

1. Új (38-as)



2. Gárdosy



3. Kapczár



4. Tomcsányi

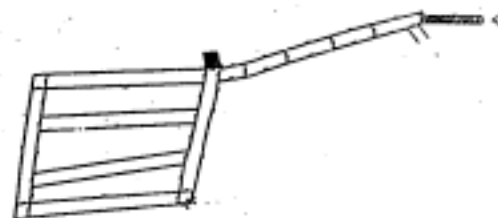

5. Lykai

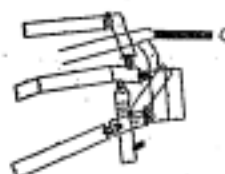

6. Dessewffy

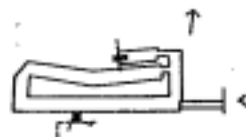

7. Roller

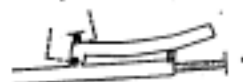

8. Felső-Bekényi

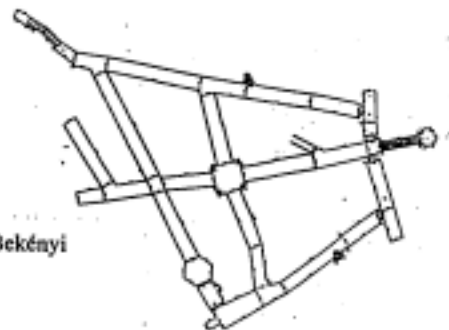

9. Alsó-Bekényi

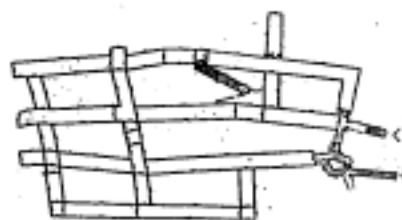

10. Fux

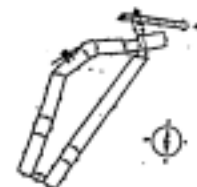

11. Kurucz

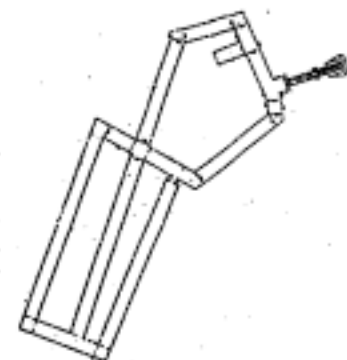

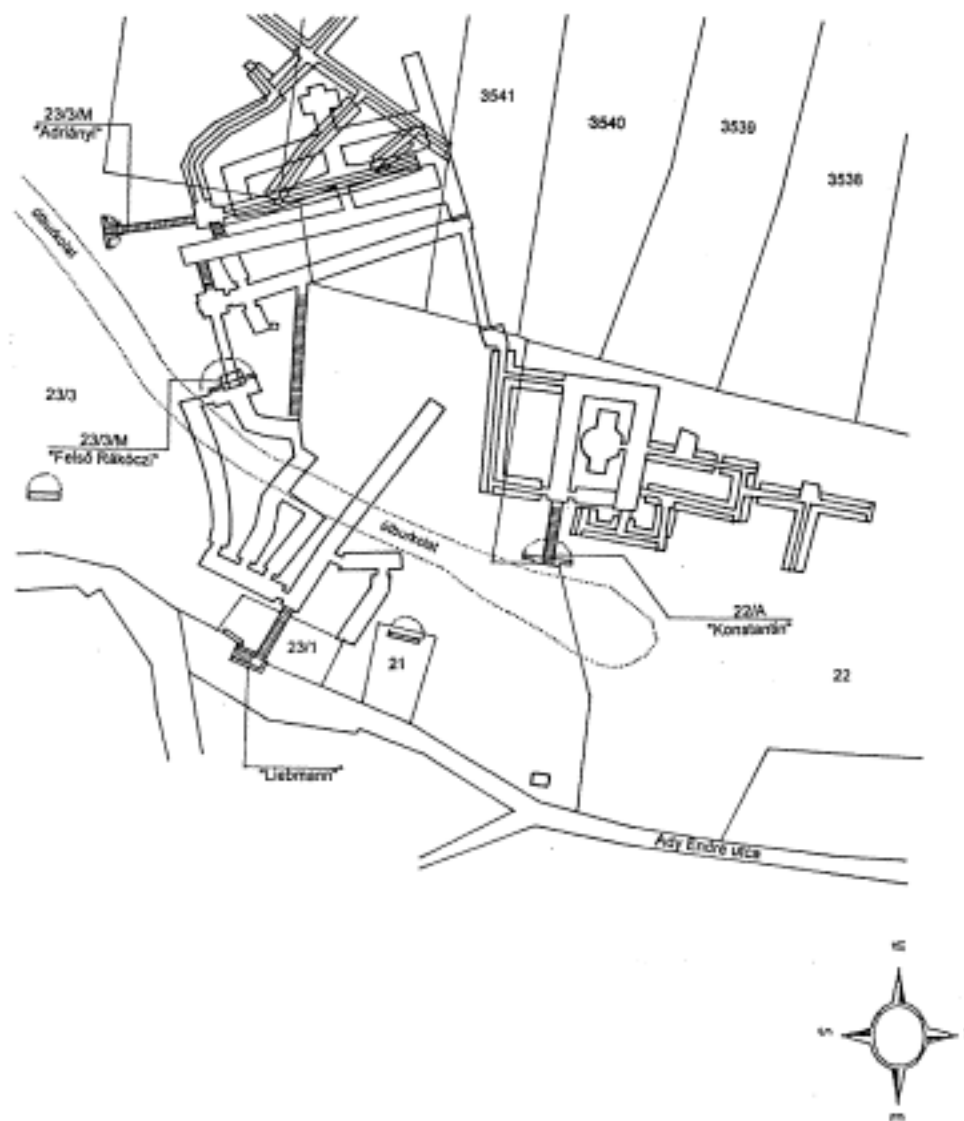

Annex 1 e-
 Supplement **WORLD HERITAGE TOKAJI WINE REGION**
 Map 19. - Map of Tolcsva Wine Museum cellars 1:750

REPUBLIC OF HUNGARY

THE WORLD HERITAGE

Supplement of the nomination

Management Plan 3.

**CULTURAL LANDSCAPE OF
TOKAJI WINE REGION**

REPUBLIC OF HUNGARY

Present study is based on various contributions

Compiled by
VÁTI KHT – Budapest

and commissioned by the
Authority of Cultural Heritage and Authority for Nature Conservation

Budapest 2001

Content of this volume

Supplement for the nomination (page 2.)

Management Plan 3. (page 8.)

Content of additional volumes

Nomination (2000)

Management Plan 1. (2000)

Management Plan 2. (2000)

REPUBLIC OF HUNGARY

THE WORLD HERITAGE

Supplement of the nomination

**CULTURAL LANDSCAPE OF
TOKAJI WINE REGION**

REPUBLIC OF HUNGARY

Present study is based on various contributions

Compiled by
VÁTI KHT – Budapest

and commissioned by the
Authority of Cultural Heritage and Authority for Nature Conservation

Budapest 2001

Supplement for the World Heritage Nomination Documentation of the Tokaji Wine Region - cultural landscape

The nominating Hungarian Republic, considering experiences of the local survey held in autumn, 2001., supplements the nomination with the following objects, situated outside the core area (see: 3. map supplement):

Hercegkút – Wine cellar rows Kőporosi and Gomboshegyi
Tolcsva – Oremus wine cellar row
Tolcsva – Cellars of the Wine Museum

Description of the supplementary objects and sites:

Hercegkút – wine cellar rows Kőporosi and Gomboshegyi

As compared to other, historic settlements of the Tokaji Wine Region, this settlement is relatively young. It was established in 1748-49 on a logged land by Swabian settlers arriving from the French-Swiss border areas, who were called by the prince Trautson János, owner of the area that time, to substitute the population decayed in the turkish wars and the Rákóczi freedom war.

Every house in the village had their own wine cellar, forming elongated wine cellar rows along the village. The cellars were sold and bought with the houses, as belonging to them. Apart from Hercegkút, there are no such tiered wine cellar rows in any other location of the .

The three-four storied Kőporosi wine cellar row is situated on the northwestern edge of the village, and comprises more than eighty cellars. The Gomboshegyi wine cellar row situated on southern edge comprises nearly eighty cellars. These cellar rows, digged into the hillsides, are running one above the other at both locations. Some of these cellars are as old as the village itself, though the majority of them have been established after the phylloxera epidemic by the end of the 19th century.

At the entrance of the cellars there are hard andesite vaults, but in the inner tracts it can be seen that the passages are digged into soft rhyolitic tuff, similarly to the majority of other cellars in the Tokaji Wine Region. The majority of

cellars consists of one or two passages, and there are some three-passage cellars as well.

Tolcsva - Oremus cellar row

Oremus Pincészet Rt., Tolcsva, Cellar row

Village of Tolcsva is set on the two sides of the Tolcsva brook, at a 100-150 metres sea-level altitude, at the hill of the Zemplén mountain and on its southern slopes, on an area of 1638 hectares, with 634 houses and 2445 inhabitants. This is one of the most famous wine producing settlement of Hegyalja, at the leg of the slope running towards the Bodrog river.

It is probable that the inhabitants hid from the Tatars into underground holes in the second half of the 13th century, and afterwards recognized that the wine stored in these holes keeps its quality for a long time. After the tatarian attack in 1241, king Béla IV. called Italian and French grape-growers for the reconstruction of the destructed vineyards. In summertime, these settlers dealt with the vineyards, and in the winters, with cellar digging. How much is the quality of wine connected to the cellar? Here is the answer from an old parable: “It is the cellar that makes the wine good.”

These cellars are dugged into the relatively high slope at the western side of the settlement, their entrance is oriented towards north-northeast. They are originated in the 13th to the 17th centuries. In that period, already with the purpose of wine aging, underground cellars were dugged into the western hillside of Tolcsva. The Oremus cellar labyrinth, almost 4000 m² in size, is accessible through several entrances. The high number of entrances shows that sometime these were individual family cellars. The connection of the cellars happened probably in the 19th-20th centuries. Temperature in the cellars is 10 °C, the humidity is 96-98 per cent. The underground cellars dispose of natural ventilation. The ventilation duct is called “soul-pit” by the local people. The cellars accommodate the so-called grey-black mould or “cellare”, which provides excellent climate for the cellar, adjusts humidity and cleans the air. The traditional 136 liter sized “Gönczi” barrels and the 200 liter volume “Szerednyei” barrels are placed on the so-called “pincegadnár”, made of hard oaktree.

Tolcsva – Cellars of the Wine Museum

Tolcsva, cellar row 1.

Among the many thousands of cellars in Tokaji Wine Region c, the Wine Museum of Tolcsva is one of the oldest and wettest, consisting of four cellars

with museum functions. The main branch is the Konstantin cellar, the other is the Adrianyi cellar, which two are connected by the branch called the upper Rákóczi cellar. The Liebmann cellar is accessible from the other side of the road, but is connected underground to the Adrianyi cellar.

The history of the Rákóczi cellar is related to the princely Rákóczi family. The Konstantin cellar is named after the rich greek Constantinus merchant family that moved to Hungary from Macedonia in the 16th century. The greek wine merchant house, operating with a centre at Tokaj, played an important role in the wine trade of Tokaj-Hegyalja until the 17th-19th century, when their role was taken over by Polish merchants. Descendants of the late wine merchants of the Constantin dynasty, – Constantin Ottó, Constantin Mihály and Constantin Miklós – did much for the blooming wine-growing of Tolcsva.

Their vineyards, cellarages and wineries were socialized in 1945. The cellarages are presently in the property of the Tokaj Kereskedőház Rt.

The cellar is almost 1000 linear metres, digged cellar, which accommodates more thousand museum piece bottles of wine, whereas the wine that is designated to be of museum quality in the future is aging in 999 wooden barrels. The wall of the cellar is covered with the grey-black mould cellare like tapestry, and this mould extends to the bottles, too. Sometimes it entirely covers the bottles, which results in a special sight. It fixes and discharges humidity on huge surfaces, thus serving as an automatic climate moderator. The temperature in the cellar is 12 °C throughout the year.

Relative humidity of the cellar is 88-50 per cent. The grey-black mould prevents proliferation of the harmful moulds as well.

The low temperature of the cellar helps the aging of wines in the “Gönczi” barrels.

The aszú-wine stored here can be conserved even for several centuries.

Wines stored in this cellarage are extremely valuable. There are products in the cellar from the early 1900's.

There are wines in the cellarage from the 1906, 1912, 1915, 1920, 1936, 1937, 1940, 1942 etc. years.

More than 80 per cent of the wines stored in the cellar belong to the three, four, five and six ‘puttony’ (basket) category.

There is also a significant stock from old vintage aszú-essences.

The best wines are handled as future museum pieces and bottled after 10-12 years of aging.

Signature on behalf of the
Republic of Hungary

List of Maps in Annex 1e - Supplement

Map 3.	Map of supplemented nomination	1:250.000
Map 13.	- Village map of Hercegkút	1:10.000
Map 14.	- Site map of Hercegkút Kőporosi cellars	1:2.000
Map 15.	- Site map of Hercegkút Gomboshegyi cellars	1:2.000
Map 16.	- Village map of Tolcsva	1:10.000
Map 17.	- Site map of Tolcsva Oremus cellars	1:2.000
Map 18.	- Map of Tolcsva Oremus cellars	1:1.000
Map 19.	- Map of Tolcsva Wine Museum cellars	1:750

List of Pictures in Annex 1e – Supplement

46 - 47.	Hercegkút – Kőporosi cellars
48 - 49.	Hercegkút – Gomboshegyi cellars
50 - 51.	Tolcsva – Oremus cellars
52 - 53.	Tolcsva – Oremus cellars
54.	Tolcsva entrance of the Wine Museum
55.	Tolcsva – drinking hall in the Wine Museum
56.	Tolcsva - Wine Museum

REPUBLIC OF HUNGARY

THE WORLD HERITAGE

Management Plan 3.

**CULTURAL LANDSCAPE OF
TOKAJI WINE REGION**

REPUBLIC OF HUNGARY

Present study is based on various contributions

Compiled by
VÁTI KHT – Budapest

and commissioned by the
Authority of Cultural Heritage and Authority for Nature Conservation

Budapest 2001

Table of Contents of Management Plan 3.

0.	Declaration of Intent for Cooperation	10
1.	Introduction – The aim and necessity of the management plan	12
2.	Description of the property and its environment	13
2.1	Description of property	14
2.2.	Delimitation of the property	15
2.3.	Description of the core area	15
2.3.1	Justification for inscription on the World Heritage List	15
2.3.2	Detailed description	17
2.3.3	Fitting of the area into the region	27
2.3.4	History and developments	27
2.4	Significance of the property	31
2.4.1	Cultural significance	31
2.4.2	Ecological significance	33
2.4.3.- 2.4.4	Social-economical importance	34
3.	Connections of the management plan and legal issues	34
3.1	The organization of management: Management Forum	34
3.2	Documents of self-regulation	35
3.3	Legal restrictions	36
3.4	Sources of possible conflicts	37
3.5	Correction procedures	38
4.	Objectives, directives	38
4.1	Register of natural and cultural values	38
4.2	List of issues endangering the property	38
4.3	Conservation and protection principles	38
4.3.1	Catastrophe protection	39
4.3.2	Fire-protection	39
4.3.3	Resolution of mining impacts	39
4.4	Objectives reinforcing the present state of protection and conservation of the property	40
4.5	Objectives – prospects	40
4.5.1	Short term objectives, priorities – actualization strategies	42
4.5.2	Mid-term objectives	43
5.	Tourism data, objectives, schedules	43
5.1	Main elements of the regional tourism offer	43
5.2	Tourism infrastructure	44
5.2.1	Transport facilities	44
5.2.2	Information	44
5.2.3	Numeric data of catering services	45
5.3	Major tourism programmes and number of visitors	46
5.4	Possible damages caused by visitors	47
5.5	Description of tourism policy	47
5.6	Special objectives concerning sustainability of tourism	47
5.7	Short- and mid-term tourism objectives	48
6.	Actualization of the management plan	48
6.1	Schedule of regular sittings of the Management Forum	48
6.2	Secretary of the Management Forum	49
6.3	Budget	49
6.4	Communication and information service	49
7.	Regular review of the Management Plan – base data of the initial state	49
7.1	Revision	49
7.2	Database of the initial state	50
8.	Annex 1e – Supplement	51

DECLARATION OF INTENT FOR COOPERATION

The Hungarian National Committee of the Ministry of National Cultural Heritage of the Hungarian Republic has sent on 28th December, 2000. the nomination documentation of the Tokaji Wine Region to the UNESCO World Heritage Centre operated in Paris.

The core area of the selected, protected region contains part of the administrative area of Mezőzombor, Mád, Rátka, Szegi, Bodrogkeresztúr, Bodrogkisfalud, Tarcál, Tállya, and Tokaj, the Rákóczi Cellar at Sárospatak, the Ungvári Cellar at Sátoraljaújhely, the Oremus Cellar at Tolcsva, the Tolcsva Wine Museum of the Tokaj Kereskedőház, and the storied roww of cellars at Hercegkút.

The concerned local governments and owners, with the coordination of the president of the County Regional Development Council of Borsod-Abaúj-Zemplén County:

- Cooperate in favor of the protection of the universal and individual values of the above areas and objects,
- Harmonize related tasks,
- Inform each other on the occurring recognized data,
- Harmonize documents to be handed in to higher forums and inform each other on plans under elaboration,
- Establish a forum for the management and development of the area nominated for world heritage status which reviews and harmonizes the management plan under construction on a yearly basis.

Present parties confirm this intent with their signature and incur a liability to abide by the above, in relation to the above areas.

The proposed version of the applying management plan and the cooperation contract of the concerned local governments, owners and the County Regional Development Council of Borsod-Abaúj-Zemplén County is prepared by the

Hungarian National Committee of World Heritage until 30th November, 2001.,
and forwards to the UNESCO World Heritage Centre.

Miskolc, 5th November 2001.

1. Introduction – The aim and necessity of the management plan

The importance of the Tokaji Wine Region has been recognized very early in history. In his edict of 1737, Charles VI, emperor of the Holy Roman Empire and King of Hungary by the name of Charles III, pronounced the area into a closed wine region for the first time in the world, thus providing the possibility and circumstances for the area to develop and to conserve its individual and unique values.

This defension has been further supported by the classification of wine-areas and various wine-laws.

In the second half of the 20th century the legislation in Hungary has made a significant step forward both in the protection of natural and cultural values. This specifically applies to the practice of the past decade, which was already geared to European legal harmonization with an aim to elaborate the conformity of the individual sectoral laws.

Paralell with the defence of interests carried out in the legislation, the National Physical Plan, which lays codified for the Parliament to accept, describes the Tokaji Wine Region as one of signal importance and value, and as an area of high sensibility from the point of view of the cultural heritage. The importance of the Tokaji Wine Region as well as its unique, special natural and cultural values and the task of the conservation of those, are thus issues of great awareness not only in the local communities but also in the national public opinion, which served as a basis for the preparation of the world heritage list inscription tender material, and for the elaboration of the following management plan.

The unique and special values of the Tokaji Wine Region have been evolved and subsists as a result of several hundred years' unchanged land-utilization practice, that is vinegrowing – and the inherent wine production.

It is an elementary duty of the Hungarian state and the local communities to conserve unchanged the values upheaped in the cultural environment of the Tokaji Wine Region and to deliver them for the future generations.

It is an elementary condition for this aim to be achieved that the old tradition of this unique form of land utilization, vine-growing and wine-production, being in sound harmony with nature, be conserved in the future.

The world heritage area only has future if the settlements concerned have future, too. Thus, it is an important factor that vine-growing and wine-production, along with tourism, should provide the local settlements with profitable opportunity to work, and it is also important to facilitate alternative developments that do not endanger the world heritage values but contribute to the development of the quality of life of the local inhabitants.

For this end, for the conservation, utilization and sustainable development of known and still undiscovered values of the Tokaji Wine Region in accord with the requirements and recommendations of the World Heritage Convention, the concerning authorities of the Hungarian state and the local governments prepare a management plan.

The task of the plan is to specify values, prospects and strategy to follow as well as short-, medium-, and long-term objectives for the proposed area on the basis of operative Hungarian laws, legal documents, local governmental decrees and with the joint resolve of the authorities concerned, in accord with the national, regional and local governmental plans and their objective and instrumental system.

Preparation of the management plan is a condition for the acceptance of the world heritage nomination. The management plan is advisory, playing a strategic guiding and influencing role, but is not compulsory.

Preparation of the management plan is an elementary condition for a series of issues:

- to secure publicity for the values,
- to provide the local and the national community with the possibility of continuous local monitoring of the realization of the objectives of the world heritage convention,
- to provide a base document for the responsible,
- to support the conservation, development and transmittance of the values of the Tokaji Wine Region cultural landscape for the future generations through the continuity of planning, programming and financing.

2. Description of the property and its environment

2.1 Description of property

The proposed property and its buffer zone are located in the north-eastern corner of Hungary, in the area of Borsod-Abaúj-Zemplén County. The chief-town of the county is Miskolc. The area of the county is 7248 square kilometres, the population is 735000.

Geographical borders of the nominated property and buffer zone: inner areas of Zempléni Mountains in the north, Hungarian-Slovakian border and the River Bodrog in the east, a short part of the River Tisza and Taktaköz in the south and Hernád-valley in the west.

The total size of the proposed area and the buffer zone is identical with the area of the Tokaji Wine Region, as is set in the Act No. CXXI of 1997.

The area proposed for inscription is the part of the administrative areas of the following settlements, which includes the most significant habitats of the Tokaji Wine Region: Tokaj, Bodrogkeresztúr, Bodrogkisfalud, Mád, Mezőzombor, Rátka, Szegi, Tarcál, Tállya, and the Ungvári Wine-Cellar in Sátoraljaújhely, as well as the princely Rákóczi Wine-Cellar situated at Sárospatak, the row of wine-cellars of Herceggút, the historic wine-cellars of Tolcsva Oremus winery and the Wine-Museum of the Tokaj Kereskedőház.

The Core Area is a natural unite of the Wine Region's. The southern and south-western boundary are the railway and the secondary road N^o 3713 running at the foot of the mountain, the northern and north-eastern boundary coincide with the administrative boundaries of relevant communities, as well as the main road N^o 37, the eastern boundary is the administrative boundary. If the boundary runs in built area, the nomination extends to the both sides of the relevant streets. The registered mines within the boundaries of the Core Area having licences according to the Act No. XLVIII of 1993 on Mines are excepted from the World Heritage area.

The buffer zone consists of the administrative areas of the following settlements except those areas which are within the Core Area: Abaújszántó, Bekecs, Bodrogkeresztúr, Bodrogkisfalud, Bodrogolaszi, Erdőbénye, Erdőhorváti, Golop, Herceggút, Legyesbénye, Makkoshotyka, Mád, Mezőzombor, Monok, Olaszliszka, Rátka, Sáradsadány, Sárospatak, Sátoraljaújhely, Szegi, Szegilong, Szerencs, Tarcál, Tállya, Tokaj, Tolcsva and Vámosújfalú.

Location and geographical co-ordinates

(WGS-84 ELLIPSOIDI KR.)

Property: north 48° 6' 12" to 48° 16' 32"
east 21° 11' 31" to 21° 26' 34"

Property and buffer zone: north 48° 4' 11" to 48° 26' 30"
east 21° 4' 14" to 21° 42' 30"

Area proposed for inscription

Area:	132,555 km ²
Buffer zone:	748,797 km ²
Altogether:	881,352 km ²

2.2. Delimitation of the property

The Tokaji Wine Region is an area that is exactly specified in the wine act. We have specified the border of the buffer zone identically with this specification. Its importance is based on legal documents, as the laws and plans define defension, restrictions and rules in accord with sustainability for this area.

The physical delimitation of the core area, containing values outstandingly concentrated, is obvious. The core area is a natural morphological unit of the wine region. The excellent quality vinegrowing areas on the south-western slopes form an insular, closed unit within the whole area. 89% of the areas in the vine cadastre are of 1st class quality.

The significance of settlements situated close to each other within the core area is shown by the high number of archaeological sites and the historical fact that these small villages have been given the rank of market town as early as the middle ages. One third of the historic monuments and the half of the 1st – 2nd class vineyards in the area are situated within the core area, which extends over one seventh of the whole wine region.

2.3 Description of the core area

2.3.1. Justification for inscription on the World Heritage List

The first closed wine region of the world (1737)

World-famous wine region

Site of finding of the Miocene fossil vine (Vitis Tokajensis)

Habitat of primary vine (Vitis sylvestris)

1000 year old viticulture

Richness in geological heritage
Diversity of soils
Particular geographical situation
Favourable climate for Botrytis cinerea (in winyards)
Particular microclimate for Gladosporium cellare (in vine-cellars)
Sessile oak for barrels and casks
Meeting point of Roman and Caucasian viticulture traditions
Common settlement heritage of several nations and religions
Architectural heritage of multilevel social system
Underground paradise (historic wine cellars)
Harvest celebrations
Living testimony of thousand year relatedness of landscape

The present state of Tokaji Wine Region reflects a unique land-use civilization that has been existing for centuries and the related cultural traditions. With centuries-old experience grape cultivation and viticulture still make use of the unique geographical, geological, geomorphologic, hydrographical and climatic conditions of Tokaji Wine Region.

The cultural landscape of Tokaji Wine Region is an organically evolved landscape. It has developed its present form by association with and in response to its natural environment and reflects this process of evolution in its form and component features.

The Tokaji Wine Region cultural landscape represents a continuing landscape which retains an active social role in contemporary society closely associated with the traditional way of life, and in which the evolutionary process is still in progress. At the same time it exhibits significant material evidence of its evolution over time. There is a close interaction between existing landscape features and agrarian forms of land-use.

The natural environment has remained a source and means of subsistence for the local population, as expressed by a number of architectural monuments around. Also the organic unity of cultural and natural dimensions in the Tokaji Wine Region cultural landscape continues to be part of the social structure, current economic activity, agrarian land use and general way of life.

Land use and the multi-national residents' way of life have always followed the varying natural conditions. The economic basis has primarily been viticulture and grape cultivation.

From cultural, historical, topographical, environmental and ecological viewpoint, Tokaji Wine Region cultural landscape is the document of land-use tradition that has remained unchanged for centuries.

The unaltered tradition of viticulture land-use is evidenced by not only the present vine-yards of the region but also the dwellings of the proposed area and buffer-zone that have displayed the special construction form of a civilisation and culture in which the lifestyle of aristocracy and peasantry, wanderers and provincial dwellers, Hungarians and immigrants have formed a unity and do so these days as well.

The lifestyle and civilisation based on wine making and viticulture still organised in accordance with a centuries-old legal system even these days.

Written evidences of the management and protective measures of Tokaji Wine Region date back to the early 1600s.

In the beginning of the 17th century the settlements of Tokaji Wine Region created a common legal system that concerns the defence of vine-yards. Statutory defence was started with decree of 1737 of the emperor Charles VI (Charles III Hungarian king). The king declared the area almost the same as the property plus buffer zone to be a closed wine region, the first in its kind in the world.

The defence was strengthened by classification of vine-yards that dates back to 1730, 1765, 1772. Even today there is strong classification in Tokaji Wine Region.

In 1893 the first Act on Wine Management was passed and it was followed by other acts in 1908, 1924, 1936 and 1997, and in 2000 a Regulation of Wine Management in Tokaji Wine Region was decided. The hill settlements of the Tokaji Wine Region have adopted their own wine regulation as well.

2.3. Detailed description

Geological, relief and hydrographic characteristics

Geographical borders of the nominated property and buffer zone: inner areas of Zempléni Mountains in the north, Hungarian-Slovakian border and the River Bodrog in the east, a short part of the River Tisza and Taktaköz in the south and Hernád-valley in the west.

The eastern part of the area under investigation is situated on the Szerencsi hills. Its surface is composed of ridges of a hill in an approximately north-south oriented strike, the average height of which is 250 metres above sea level. The average value of the relative relief is 70 metres per square-kilometre. More than 80% of the surface is covered by sarmatian rhyolite tuff. Its elevations are bare rhyolite and riodacite cones. Its precious mineral substances are zeolite, kaolin, hydro-quartzite and bentonite. At the foot of the hills, in a south-south-eastern

direction from the Tokaj mountain, we can find a 150 metres deposit layer of gravel, sand, warp and fresh water burden. In the upper layers the soil is composed of brown soil developed on lymph-like clay, while in the lower layers it is characterised by chernozem with patches of lime.

The core of the Tokaj hill, which constitutes the southern peak of the Zemplén mountains, is made up of andesite, rhyolite and rhyolite tuff. The foothill slope is covered by loess up to the height of 250 metres in a cone-like way. At lower parts its thickness can reach up to 30-40 metres. The average relative relief of the hill is 117 metres per square-kilometre. Its natural substances are andesite and rhyolite tuff. Its determining soil type is the acidic brown soil developed on lymph-like clay.

The average height of the slope ranges exposed to the south-east, north and west-north-west direction from the Tokaj hill is 514 metres above sea level. More than 80% of the surface is endangered by soil erosion. The degree of the annual erosion reaches 1 to 3 centimetres. Under the surface the product of the volcanic post-activities can be found, the surface is covered by solifluctional deposit or at some places by loess. Among the natural substances zeolite, kaoline and bentonite are substantial. It is also possible to find andesite, flint and hydroquartzite here. 55% of the soil is brown forest soil developed by clay infiltration and 34% is brown soil. The proportion of the barren stony areas is only 4%.

Bodrogköz is situated between the wave band of the Bodrog and Tisza, beneath the above mentioned slope range. The little region is a flat area between 95 and 128 metres high above the sea level. The average relative relief is 4 metres per square-kilometre. The 90% of the surface is dominated by Neoholocene casting formations, such as meadow clay and marshy deposits. Its soil is mainly determined by chernozem as well as marsh soil and to a smaller extent sodic soil.

The most significant water resources are the Bodrog and the Tisza rivers as well as the backwaters and oxbows created after their regulation. The water reservoir at Tiszalök made the Bodrog navigable, too. Other significant, but smaller water flows in the area are the Szerencs brook, the Gilip brook (dammed to a 39 hectare water surface next to Monok), the Tatka channel, the Fennsík channel (created by the confluence of Fördő and Mádi-brook), and the Ronyva, Hercegkúti, Szarkakúti, Tolcsvai and Bényei brooks, respectively, flowing into the Bodrog. Most of them are seasonal or abate during the summer.

Local climatic characteristics

Higher areas are situated at the border of the moderately wet zone, the lower areas belong to the moderately hot and dry climate. The amount of sunshine is around 1900-2000 hours per year, in summer the average is between 750 and 790 hours, while in winter it is 200 hours on average. The annual mean

temperature is between 9.6 and 9.9 °C, during the vegetation season it is around 16.3-16.9 °C. The daily mean temperature is over 10 °C over about 184 days a year, namely between 14th April and 14th October. On average the daily mean temperature does not go below freezing for 180 days but on the southern slopes this period may last longer than 190 days. Between 20th April and 15th October the temperature is above freezing. The mean of the highest degrees within a year is 33°C and the lowest is -16°C. The annual amount of rain is around 600-620 mm out of which 370-390 mm arrive in the vegetation season. Its climate makes it possible to grow cultivated plants that require hotter climate. The Tokaji Wine Region is perfect for cultivating grapevines, while the flatter areas provide perfect conditions for growing plants on tillage and at places with high subsoil water level grazing and grassland farming would be preferable.

Flora and fauna

The area according to plant geography classification can be ranked among Tokajense flora locality of the larger North-Hungarian mountains flora area (Matricum) within the Hungarian flora land (Pannonicum). Hornbeam and Turkey oaks (*Quercus petraea*-*Carpinetum*, *Quercus petraea*-*cerris*) form the climatic associations on the less typical slopes exposed to the north and in the more fresh valleys. On the south-facing slopes the thermophil oak (*Corno-Quercetum pubescenti-petraea*) is peculiar. *Cornus mas* (Cornelian cherry), *Crataegus monogyna* (singleseed hawthorn), *Viburnum lantana* (Wayfaring tree) and *Amygdalus nana* (dwarf almond), which can be found in large number in some places, are the most remarkable among the shrubs. Mostly in warmer location it is more frequent to find soft-stalked plants such as *Iris variegata*, *iris graminea* ssp. *pseudocyperus*, *Aster cinereus*, *Lathyrus pisiformis* and *Stipa stenophylla*. 17 species of orchid live on Kopasz mountain.

Forests mostly consist of non-native pine- and locust-trees. The damaging effect of the former one is changing the chemical properties of the soil: the fallen pine needles sour the soil strongly. The latter one consumes the nutritives of the soil, practically exploiting it, while forming an ineradicable polycormon colony. Both have the effect of totally thinning out their undergrowth because of the deep shadow (pine) and allelopathical features (locust), and they do away with the territory of valuable soft-stalked populations.

The most typical cultivated plant of this area is grape-wine, but in southern locations there is also peach, plum, and rarely almond. The most typical ploughland grain is wheat, but we can also mention maize, rye and sunflower.

Regarding the animal population, the regions of Tokaj-Bodrozug Landscape Protection Area has the most important role. It is a significant nestling and brooding place for birds and rich in fish. The most typical and precious species are the night heron, spoonbill, common heron, cormorant, white stork, Short-

toed Eagle, Imperial Eagle, Lesser Spotted Eagle. Two of the seven or eight pairs of stock owl known in Hungary live on Nagy-Kopasz.

In the stock of game there are big populations of rabbit, deer and wild boar living in the forests above vine-lands and meadows. Animal keeping is not considerable.

Tokaj-Bodrozug Landscape Protection Area is quite prominent among nature conservation territories, and also the examined parts of the Landscape Protection Area of Zemplén, but we can mention some nature conservation areas with local importance protecting the same value and the individually protected species of different plant and animal.

Areas of protected nature: Tokaj-Bodrozug (District of landscape protection; partly covering the property only), Bodrogszegi Várhegy (Protected area), Tállyai Patócshegy (Protected area), Zempléni District (District of landscape protection; partly covering the property only), Erdőbénye woody pasture (Protected area)

Cultural property

Archaeological values

In the Neolithic in Boldogkőváralja, there was a human settlement in which people dealt with making obsidian and flint implements. (Obsidian finds: Erdőberénye-Liget, Aranyosvölgy, Erdőhorváti etc.). People using copper and bronze tools (“culture of Bodrogkeresztúr”) used to live in the Northern foreground of the Tokaj mountain (Dereszla-tető, Henye). Finds from early Bronze Age (“culture of Hatvan”): at the boundaries of Tarcal, Mézesmál-tető, Szerencs, Mezőzombor, Erdőberénye and Sáradsadány.

Bronze Age finds: Tiszaladány-Nagyhomokos (Ürgehát)

Bronze Age: finds of the “culture of tumuli” in Rakamaz

pots from the “culture of Füzesabony”: Tokaj, Szerelmi dűlő (Parcel of Love)

finds from the “culture of Piliny”: Tarcal, Mád, Bodrodkeresztúr, Tokaj (motorway)

finds from the “culture of Gáva: the area of Tokaj, Szerencs, Tállya Mád, Tarcal, Tolcsva, Bodrogkeresztúr

Finds of the migration period: Vandal settling: Tiszaladány-Nagyhomokos

Hun finds: Mád, Végárdó, Tiszaladány

Avar findspots: Tiszadada, Tiszalök, Tiszaeszlár, Bashalom, Tiszanagyfalu

Pots of the migration period: Tokaj, Szerelmi dűlő

Finds, pots and establishments from the Árpád Age:

the “tomb of the Leader Tarcál” in Tarcál, above Mestervölgy, tomb of a leader in Rakamaz (in both of them there is a sword of the leader, the famous silver satchel plate etc.)

in Rakamaz-gyepföld: silver disk with griffins used as a hair ornament

in Karos: a tomb of a leader (sword, silver satchel plate, sun-disk)

in Kenézlő: populous common cemeteries

in Tiszaeszlár: tombs of a leader and of militants, common cemetery, village of Tiszalök-Rázompusztá

in Mezőzombor: female tomb of high rank

the tomb-site in Sárospatak

“treasure of Tokaj” silver-set in Zalkod-Szegfarka

earth fortification from the 10-11th century in Szabolcs

Hymesudvar (earth fortification of Tokaj), around 1200

Settlement-related and architectural values

The settlement system and the settlement forms of the Tokaj Wine Region are inseparable from the morphological and hydrographical features of the area.

One of the frames of the interrelationships between settlements and of the settlement system of the region is the Bodrog, and the other one is the Stream Szerencs and the River Hernád at the western border.

There is a chain of settlements along the Bodrog. These settlements are located on the right bank of the river meandering at the foot of the Zemplén mountain range. Bodrog is one of the water-collecting rivers of the mountain range, and there are further settlements to be found in the valleys of the smaller streams falling into the Bodrog. The Bodrog is emptying into the Tisza at Tokaj, marking one of those ancient passing-places which provide the settlements between the two banks of the Tisza with connection.

The Szerencs is falling into the Takta through a broad mouth, having settlements on its both sides. The extremely valuable capabilities of the area, and its aptitude for being a good place to settle down had already been recognised by the first Magyar settlers of Hungary. The name Tokaj itself, coming into Hungarian as an Armenian loanword meaning ‘grape’ at around the 10th century, is an evidence for the early origin of the settlement, its system of ethnical relationships and the fact that viticulture was known at that time. The changing of the area into wine region deeply influenced the thinking and culture of the local population. However, by the conversion of the area into wine region, we do not only mean regal regulations, but rather the uniformed environmental culture typical of Tokaji Wine Region, that can be identified even these days.

In the built environment of the region, the architectural cultures of many centuries are intertwining in a unique way: there can be found Catholic churches of medieval origin, Orthodox churches from the 18th-19th century, monuments of the and Jewish sacral architecture, documentaries of the princely architecture of castles, castles and mansions of the aristocracy as well as dwelling-houses, wine houses and cellars of the people.

An important monument of the early settlement of the area is the Roman style Catholic church in Bodrogolaszi from the 12th century, situated in the buffer zone.

In every settlement of the nominated property there can be found a gothic Roman-Catholic church from the Middle Ages.

In Tokaj and in Tállya, there are ruins of castles from the 14th century, and among settlements in the buffer zone, it is Monok, Sárospatak and Szerencs where there are Medieval castles.

The noble castles and mansions are the emblems of the wealth gained from viticulture, from which four of them are standing in Tarcál, and another nine are in the buffer zone. These buildings were built in the 18th-19th century, in the glory of the Tokaj Wine Region.

The synagogues and other sacral buildings in Tarcál, Tokaj and Mád, the Orthodox and Roman-Catholic churches of Tokaj, and the Orthodox churches of Abaújszántó, Bodrogkeresztúr, Bodrogolaszi, Sárospatak, Sátoraljaújhely and Szerencs, all protected by the Ancient Monument Act were also built at this time.

The density of monuments is marked by the protected areas of monuments, of which one happens to be in Tokaj and the other one in Tállya, and another ten are situated in the settlements of the buffer zone.

The most typical establishments of Tokaj are the cellars. The cellar of King Kálmán in Tarcál was already mentioned in 1110.

The two basic cellar types preferred in Tokaj were the vaulted and the carved varieties. The vaulted was basically a space underneath a residential building, both with an identical floor plan. The cellar was usually dug when the house itself was built, and mainly accessed from the porch. In this set-up, the grapes were processed in a room to the rear of the house, just above the cellar.

The other version, the carved cellar was not directly linked with the building. On the surface level, only a stonework entryway with a latticed gate made from wood or steel was visible. The cellars carved in volcanic tuff did not need to be reinforced with vaults because the rock was strong enough to support the ceiling. In Tokaj, 80-85 percent of all the cellars were made this way.

The most interesting type is the multi-level cellar labyrinth with a jumbled floor plan. Created over the centuries by horizontally and vertically linking cellars carved near each other, these mazes appeared in the commercial centers of the Foothills of the Tokaji Wine Region, in Erdőbénye, Mád, Tállya and the town of Tokaj. Their most famous example is the cellar network in the Ungvári district

of Sátoraljaújhely, which evolved through interconnecting 27 separate cellars side by side and one on top of another. This labyrinth has the capacity to hold 13000 casks of the Gönc and Szerednye type.

This cellar labyrinth, the Ungvári Cellar in Sátoraljaújhely is part of the nomination. The historically unique and attractive Rákóczi Cellar in Sárospatak, that has 1000 metres long ways, is also part of the nominated property. Within the nominated property, there are several similar and valuable cellars like those.

Sátoraljaújhely, Ungvári Wine-Cellar

In the deed of foundation of Sátoraljaújhely, there are mentions about the origin of the wine-cellars going back to the 1200's. The original settlers went to the foothill of the Sátor hill from the floods of the Bodrog river, and probably used the cellars, excavated in rhyolitic tuff, for food storing and as shelter from their enemies.

The value of Tokajhegyalja and thus the district of the Ungvári cellars rised up along with the decay of the South-Hungarian vine regions in Szerémség, during the 16th century invasion of the Turks.

Denomination of the cellars derive from their situation along with the wine-transporting main road, going in the north-eastern direction, which road goes through the city of Ungvár.

In its present form, the Ungvári wine-cellars are on a 50.000 m² open air area, in the northern part of Sátoraljaújhely. The 14-16 km long, four storied wine-cellars has been elaborated through the horizontal and vertical contraction of 27, originally individual cellars, whose storing capacity is 13.000 barrels from Gönc and Szerednye, (20.000hectolitre i.e. 528.000 gallons). It is a labyrinth type winery. The base width of the branches is 180-200-250 cm, their height is 170-190 cm. Characteristic decoration of the cellars are the so-called circle branches, that vary from 6-8 m through 20-25 m up to 50-60 m in length. The conformation and maintenance of the expressively good cellar climate is supported by more than 15 m deep main ventilating holes, and smaller ventilating holes connecting the individual levels.

The basic value of the winery is implied in its special micro climate providing due maturation of Tokaji wine specialities – Szamorodni and Aszú wines. The optimal regulation of air motion is actuated through the controlling of the ventilation holes and the so-called air-doors. It is supplemented by the grey-black mould, cellare on the walls of the cellars. As a result of all these, the temperature of the cellars is between 9-11 °C, the relative humidity is between 85-95%, all through the year.

The Ungvári Cellar is the property of the state-owned Tokaj Kereskedőház Rt (Tokaj Trading House Co.).

Sárospatak Rákóczi Cellar

This cellar is situated in the historic centre of Sárospatak, 14 metres deep under the park of the Rákóczi Fortress-Castle (in volcanic rock). Its total length is about 1000 metres, accommodating tokaji wines, and thus, one of the largest and most beautiful winery of Tokaji Wine Region (Hegyalja), as well as a living proof of the wine and vine-culture of Hegyalja and Sárospatak, going back to the Árpadian age (10th-13th century). It is duly enlisted as a historic site of Sárospatak, since it has been the property of famous personalities of the castle and the region since the XVI. century, being one of the repositories of their wealthy. The past of the cellar under the fortress park is known back to the times of Péter Perényi, who erected the fortress between 1534 and 1541. Its major owners were King Miksa I and Dobó Ferenc. In 1612 it got in the propriety of Mihály Lorántffy. As a result of the marriage of György Rákóczi I - the prince of Transylvania - and Zsuzsanna Lorántffy the estate increases significantly, thus the winery passes to the property of the Rákóczi princes until the fall of the Hungarian independence war (1711). The owners after that were as follows: the princes of Trautsohn between 1712 and 1776, the princes of Bretzenheim between 1806 and 1875, princes of Windisch-Graetz between 1875 and 1950. From 1951 it was a property of the Tokajhegyaljai Pincegazdaság (Tokajhegyalja Winery), whereas from 1971 it was handled by the Tokaj State Farm Wine Combinat. At present – since 1992 – it is owned by Megyer Rt. (Megyer Inc.). The cellar reached its final extension between 1776-1791, there has been no enlargements or restructuring since that time. Humidity in this cellar of excellent consistency and constant climate is 96%, which is provided by the velvety grey-black mould (*Gladosporium cellare*) growing steadily and thickly on the walls. The *Gladosporium cellare* is an individual feature of the Tokaji cellars. This special mould, is in close connection with the Aszú and Szamorodni wines. The wine is necessary for the growing of the mould, and it gives special character to the wine. Thus the cellar is capable of seasoning excellent quality and high consumption value Szamorodni and Aszú wines.

The winery can accommodate 900 pieces of “Szerednyei” barrels, which barrel is a peculiarity of Tokaj-hegyalja. There are two taster chambers in the cellar. In the Great Taster, which may room 80 people, large groups can be received. The Small Taster may accommodate only 14 people. There are 7 coats of arms above the tables, symbolising the most important settlements of the region: Sárospatak, Tarcal, Tokaj, Mád, Tállya, Sátoraljaújhely, Tolcsva. Another historic sight of the cellar is the Rákóczi bacon fryer, where – most probably – the Rákóczi family tasted its wines. In 1957 a museum has been established on purpose of conserving the best vintage Aszú wines and rarities for the posterity. The owner of the Rákóczi Cellar is Megyer Rt. (Megyer Inc.). The firm utilises this famous winery of historic past in the fields of viticulture and tourism.

Hercegkút – wine cellar rows Kőporosi and Gomboshegyi

As compared to other, historic settlements of the Tokaji Wine Region, this settlement is relatively young. It was established in 1748-49 on a logged land by Swabian settlers arriving from the French-Swiss border areas, who were called by the prince Trautson János, owner of the area that time, to substitute the population decayed in the Turkish wars and the Rákóczi freedom war.

Every house in the village had their own wine cellar, forming elongated wine cellar rows along the village. The cellars were sold and bought with the houses, as belonging to them. Apart from Hercegkút, there are no such tiered wine cellar rows in any other location of the .

The three-four storied Kőporosi wine cellar row is situated on the northwestern edge of the village, and comprises more than eighty cellars. The Gomboshegyi wine cellar row situated on southern edge comprises nearly eighty cellars. These cellar rows, dugged into the hillsides, are running one above the other at both locations. Some of these cellars are as old as the village itself, though the majority of them have been established after the phylloxera epidemic by the end of the 19th century.

At the entrance of the cellars there are hard andesite vaults, but in the inner tracts it can be seen that the passages are dugged into soft rhyolitic tuff, similarly to the majority of other cellars in the Tokaji Wine Region. The majority of cellars consists of one or two passages, and there are some three-passage cellars as well.

Tolcsva - Oremus cellar row

Oremus Pincészet Rt., Tolcsva, Cellar row

Village of Tolcsva is set on the two sides of the Tolcsva brook, at a 100-150 metres sea-level altitude, at the hill of the Zemplén mountain and on its southern slopes, on an area of 1638 hectares, with 634 houses and 2445 inhabitants. This is one of the most famous wine producing settlement of Hegyalja, at the leg of the slope running towards the Bodrog river.

It is probable that the inhabitants hid from the Tatars into underground holes in the second half of the 13th century, and afterwards recognized that the wine stored in these holes keeps its quality for a long time. After the tatarian attack in 1241, king Béla IV. called Italian and French grape-growers for the reconstruction of the destructed vineyards. In summertime, these settlers dealt with the vineyards, and in the winters, with cellar digging. How much is the

quality of wine connected to the cellar? Here is the answer from an old parable: “It is the cellar that makes the wine good.”

These cellars are dugged into the relatively high slope at the western side of the settlement, their entrance is oriented towards north-northeast. They are originated in the 13th to the 17th centuries. In that period, already with the purpose of wine aging, underground cellars were dugged into the western hillside of Tolcsva. The Oremus cellar labyrinth, almost 4000 m² in size, is accessible through several entrances. The high number of entrances shows that sometime these were individual family cellars. The connection of the cellars happened probably in the 19th-20th centuries. Temperature in the cellars is 10 °C, the humidity is 96-98 per cent. The underground cellars dispose of natural ventilation. The ventilation duct is called “soul-pit” by the local people. The cellars accommodate the so-called grey-black mould or “cellare”, which provides excellent climate for the cellar, adjusts humidity and cleans the air. The traditional 136 liter sized “Göncki” barrels and the 200 liter volume “Szerednyei” barrels are placed on the so-called “pincegádnár”, made of hard oaktree.

Tolcsva – Cellars of the Wine Museum

Tolcsva, cellar row 1.

Among the many thousands of cellars in Tokaji Wine Region c, the Wine Museum of Tolcsva is one of the oldest and wettest, consisting of four cellars with museum functions. The main branch is the Konstantin cellar, the other is the Adrianyi cellar, which two are connected by the branch called the upper Rákóczi cellar. The Liebmann cellar is accessible from the other side of the road, but is connected underground to the Adrianyi cellar.

The history of the Rákóczi cellar is related to the princely Rákóczi family. The Konstantin cellar is named after the rich greek Constantinus merchant family that moved to Hungary from Macedonia in the 16th century. The greek wine merchant house, operating with a centre at Tokaj, played an important role in the wine trade of Tokaj-Hegyalja until the 17th-19th century, when their role was taken over by Polish merchants. Descendants of the late wine merchants of the Constantin dynasty, – Constantin Ottó, Constantin Mihály and Constantin Miklós – did much for the blooming wine-growing of Tolcsva.

Their vineyards, cellarages and wineries were socialized in 1945. The cellarages are presently in the property of the Tokaj Kereskedőház Rt.

The cellar is almost 1000 linear metres, digged cellar, which accommodates more thousand museum piece bottles of wine, whereas the wine that is designated to be of museum quality in the future is aging in 999 wooden barrels.

The wall of the cellar is covered with the grey-black mould cellare like tapestry, and this mould extends to the bottles, too. Sometimes it entirely covers the bottles, which results in a special sight. It fixes and discharges humidity on huge surfaces, thus serving as an automatic climate moderator. The temperature in the cellar is 12 °C throughout the year.

Relative humidity of the cellar is 88-50 per cent. The grey-black mould prevents proliferation of the harmful moulds as well.

The low temperature of the cellar helps the aging of wines in the “Gönczi” barrels.

The aszú-wine stored here can be conserved even for several centuries.

Wines stored in this cellarage are extremely valuable. There are products in the cellar from the early 1900's.

There are wines in the cellarage from the 1906, 1912, 1915, 1920, 1936, 1937, 1940, 1942 etc. years.

More than 80 per cent of the wines stored in the cellar belong to the three, four, five and six ‘puttony’ (basket) category.

There is also a significant stock from old vintage aszú-essences.

The best wines are handled as future museum pieces and bottled after 10-12 years of aging.

2.3.3 Fitting of the area into the region

The core area and the buffer zone are situated in Borsod-Abaúj-Zemplén county, which is in the northeast part of Hungary. This county, along with two additional, comprises the North-Hungarian planning-statistical region of Hungary.

Landscape utilization of the country is specified by its natural geographical making. The county can be divided into two, significantly differing landscape units, the hill area, which shows a great morphological variety and the plainland, which is capable of agricultural utilization. The culture of the Tokaji Wine Region is situated at the border line of these two areas, on the good-lying, shiny and mild slopes, which are an excellent area for vine growing.

2.3.4. History and developments

Tokaj is claimed by many with certitude to have been the centre of Attila's Hun empire. This claim may well be true. What is an undisputed fact, however, is that the region became all-important for the occupying Hungarian tribes, who cherished their kinship with the Huns.

The salt-road coming from the salt-mines of Máramaros leading to Buda used to cross the Tisza at Tokaj foothills, so that is the place where the Polish merchants

travelled to the Balkans and to Transylvania or to the Upper-Hungarian regions. The crossing-place at Tokaj was created in the crossing of roads and war roads. Soon enough after they had arrived, the Hungarians settled the area of Tokaj and, even before that, the Bodrogeköz, where they found shelter in the bogs between the bifurcating waters. Hungarians here enjoyed relative protection for the next eleven hundred years. How much this refuge was needed became obvious in 1241, when it was through this region that Batu Khan's Mongolian hordes invaded the country to run down the Hungarian royal troops on the Muhi Puszta, just a few kilometers south of Tokaj. Although the Tartars failed to capture Sárospatak, the most prominent fortification in the area, a quarter of Tokaj's inhabitants perished during the year and a half of the Mongolian Occupation.

In the first centuries of the Hungarian Kingdom, the decisive part of the Tokaj region belonged to the Crown, while Patak (short for Sárospatak) and Szerencs served as the headquarters of the ispán, the land-steward reporting to the royalty. Through donations, the original crown properties were turned into feudal estates controlled by the local nobility by the 13th century.

The flourish of Hungarian viticulture owed a great deal to Latin peoples who found a new home in the country. They often arrived in the company of German settlers, or else they would found towns together with them. The Latin presence proved especially crucial in the Szerémség, in Southern Hungary one of the most important Hungarian wine regions prior to the heyday of Tokaj. In fact, the Latin peoples are assumed to have added an entire chapter to the history of the Foothills of the Tokaji Wine Region, albeit only scant evidence—material or written—remains to support that claim. Latin settlers were first invited to settle down in Tokaj by Béla III (1130-1162), and then by Béla IV (1235-1270). By all likelihood, these immigrants were Walloons from Northern France, subject to being lumped together in Hungarian with all the neo-Latin peoples as *olasz*, meaning “Italian”. However, certain researchers claim that these early settlers had indeed come from Italy, and were arguably—if not verifiably—responsible for propagating the Furmint grape. The memory of these settlers is enshrined in the names of villages such as Bodrogolaszi, Olaszliszka, and presumably Tállya. The Felvidék, or Upper Hungary, has been home to Germans since the infant centuries of the Hungarian State. They settled in the Szepesség forming a tight community, and generally maintained a decisive presence in the towns. Eventually, most of them blended in with the Hungarian matrix, but persisted in their identity for a long time in terms of culture and tradition.

The barons finally bowed to the House of Anjou (1308-1387) that had followed Árpád's Dynasty (895-1301), but in the 1500s, under the reign of the Hunyadis, the Upper Country fell under the dominion of a new foe, the Czech Jan Griska. As the leader of the Hussites, a religious group driven out from the Czech lands, Griska resisted Hunyadi Mátyás (Matthias Corvin) for a long period of time. When he was finally defeated by this last great Hungarian king, he became one

of the most loyal subjects of the crown. The memory of the Hussites is still guarded by a handful of characteristic buildings along the Hernád. In the 14th and 15th centuries, the valley of this river played a role perhaps even more remarkable than that of Tokaj. It was itself abundant in thriving vineyards, but its essential advantage consisted in its geographical-economical location.

In the first half of the 16th century, one third of Hungary fell under the Ottoman Occupation.

Tokaj was a veritable no man's land in those days. It fell outside the territories under Ottoman rule, but remained vulnerable to raids. Although the area formally belonged to the Hungarian Kingdom, through cultural and political ties it was closely attached to the Transylvanian Principality, which remained a huge sore in the eyes of the Habsburg Court for its successful resistance. Due to its geographic position in a shredded country beleaguered by incessant uncertainty and strife, Tokaj became a site of deployment by the second half of the 16th century.

At the earliest, the birth of Tokaji Aszú can be dated to around 1630, the year that newcomers to Tokaj will generally be told first. Legend has it that in that year, Szepsi Laczkó Máté, evangelist of Erdőbénye and pastor at Lórántffy Mihály's domain, wanted to lead the villagers to the harvest as usual, but fears of an Ottoman incursion held them back day after day. By the time they finally did venture into the vineyards, botrytis infection had set in and shriveled the grapes. The workers proceeded to pick these crinkled berries anyway, and the pastor placed the wine made from them as an Easter gift on the table of Lórántffy Zsuzsanna, daughter of his lord and who was engaged to Rákóczi György I, Prince of Transylvania.

At the beginning of the 17th century, the Transylvanian principality was then acquired, although only held for two years, by the founder of a dynasty, the Rákóczis, which became one of the most prominent families in the annals of Hungarian history, and whose destiny was intertwined with Tokaji's rise to world fame.

Rákóczi György still held the throne in 1631, the year for a long time believed to be the official date of birth of Tokaji Aszú. In fact, the wine of Tokaj had already been a major source of income for the Rákóczis, and thus served as a pillar of the Princes' power. As the fame of the magnificent drink reached ever farther, more and more wealth was accrued by the local culture.

The dawn of the 18th century saw the last great member of the family step into the arena of history. The moment of Rákóczi Ferenc II came when the Ottomans had been driven out of nearly all of Hungary, and it seemed that no one would be able to resist the Habsburg Court. Coming into an inheritance after a turbulent childhood, Rákóczi Ferenc II swore to the Catholic faith, but he really thrived on the same ideals as his Protestant ancestors. He was destined to be chosen, in 1703, as the prince who would lead Hungary's longest ever war of independence.

During the eight years of the war, Ferenc forged a solid network of international relations. While Tokaji Aszú, the most valuable treasure of his holdings, had for decades generated the revenue needed to carry on the struggle for independence, so did the fame of the wine ascend in the wake of that heroic effort. Tokaji Aszú made money as well as nurtured relations. It was a commodity, but it also served as a special gift that paved the Prince's way into the courts of Louis XIV, King of France, and of the Russian Emperor, Peter the Great. Tokaji was esteemed as a precious rarity—as “the wine of kings and the king of wines.”

The drive for independence led by Rákóczi Ferenc II was defeated in 1711. The Prince fled to Turkey, leaving his estates in Tokaj to the monarch in power. Over the remaining nine decades of the 18th century, Hungary slowly found its position within the Habsburg empire, but it never relinquished its separate identity. The 150 years of anguish were now followed by peaceful times in comparison. Relying on a steady market demand and a tradition of wine-making that had been honed for centuries, Tokaj enjoyed relative prosperity through most of the period. In fact, by 1780, the Foothills of the Tokaji Wine Region became the most densely populated region of the country. Its rate of 52 inhabitants per square kilometer was nearly double the national average, and it even exceeded that of France or the more advanced German states. Tokaji was highly in demand, and the estates were constantly short of helping hands. The élan of the 17th century remained tangible in these more tranquil times. Poland emerged as a distinguished market for Tokaji, and the Russian emperors maintained in Tokaj what amounted to a colony commissioned to supply the Court with the excellent wine.

The Tokaji had had a great attraction for the people of the surrounding areas from the very beginning.

The Slovaks typically settled down in the northern reaches of the Zemplén, now part of Slovakia, and in tiny villages deep in the interior of the same range. They were regarded as hard-working day labourers who knew how to work with timber and wood, and who often worked in the vineyards of Tokaj.

The Orthodox Ruthenians kept coming into the area from the 16th to the 19th century.

From 1733 to 1798, the Russian Czars ran a small colony that they called the Wine Purveyors' Commission in Tokaj, to ensure a steady supply of the excellent wine (originally set up by empress Anna Ivanovna).

The Greeks emerged as major players in the trade of Tokaji toward the end of the 17th century, and they held on to that role until the late 1700s. They were moved to the town of Tokaj by Rákóczi Ferenc II after Szatmár had been captured, and they soon found a niche in the community. Most of them were of Macedonian extraction, and ultimately only few decided to choose the Foothills of the Tokaji Wine Region as a permanent home (an example was the Konstantin family in Tolcsva). As Turkish citizens, the Greek merchants were rarely distinguished by the locals from their Serbian and Armenian colleagues.

Starting in the late 1700s, they were slowly superseded by the Jews, who arrived and settled in increasing numbers. Historians have shown that, from the beginning of the 17th century, Polish Jews had commercial interests in the wine of Tokaj. The first major wave of Jewish emigration to Hungary, triggered by the insurrection of Hmelnitzky's Cossacks in 1648, reached Tokaj in the second half of the 18th century. The most important Jewish communities were formed in Mád, Tolcsva and Sátoraljaújhely, and later in the town of Tokaj. When the second wave hit between 1800 and 1867, the Jews came to play a significant role in the business of each community in the Foothills of the Tokaji Wine Region, and a decisive one in its wine trade.

The 19th century was a period of gradual impoverishment, and also of continuously searching for a way to once again put Tokaji on the table of the most discriminating consumer.

The end of the century saw a well-known problem hit Tokaj: Phylloxera duly appeared on the scene. It raised its head at the relatively late date of 1885, but when it did, it promptly proceeded to destroy most of the vineyards in a matter of a few years.

The Jewry was wiped out by World War II; ownership by the aristocracy and the few smallholders about to join the bourgeoisie was abolished by the communism that followed it. In this way, those who had formed the decisive, most skilled and most apt force behind the growing and trading of wine in Tokaj vanished or drifted to the margins of life.

The political changes in 1990 shook Hungarian society to its foundations, releasing processes from the grip of slumber with elemental force. Once again, the best were given a chance to create the best, in Tokaj and elsewhere in the country. And Tokaji was indeed reborn.

2.4 Significance of the property

2.4.1 Cultural significance

The landscape of the Tokaji Wine Region - where this princely wine is produced for hundreds of years - is uniquely various and wonderful, showing up a special cultural value that has been elaborated and saved for us through the organic transforming work of people living in symbiosis with this area.

Tokajhegyalja is a kind of open book, from which the history of the area can be read out continuously.

Searching for clues in time, we cannot even begin to say for sure in what form viticulture existed in the Foothills of the Tokaji Wine Region during the time of Hungarian settlement 1100 years ago. Although we have no material evidence, we can be quite certain that Hungarians already grew grapes and made wine in these early days. Hungary's viticulture has a twofold origin: It is partly nourished by western and Latin roots, and partly by eastern traditions. For a long

period, Hungarians had lived in the antechamber of the Caucasians, where they acquired their winemaking skills. Proof of this are those vocabulary items which found their way into the Hungarian language around this time as Turkish loan words, like szőlő (“grape”), csiger (“marc wine”), bor (“wine”), ászok (“cask”). As they occupied what became their permanent homeland in the Carpathian Basin, Hungarians were probably aware early on of Tokaj’s excellent potential for growing grapes, and they tried to transplant the knowledge they had accumulated in the Caucasians.

From the second half of the 12th century, when Walloon settlers arrived, we can clearly talk about viticulture in Tokaj; one hundred years later abundant records attest to the fact that grapes were grown throughout the area. The memory of the Wallon settlers is recorded in the names of settlements as Olaszliszka, Bodrogolaszi.

After 1526 the Tokaji Wine Region started to play a more and more important role since Hungary lost its best vine-growing areas in the South in the Mohács battle.

The settlement network harmonises with the land in both its scale and internal structure within the proposed property and buffer zone. There is a rich and valuable stock of historic monuments which is an architectural documentation of the traditional agrarian land use and way of living. The area has been continuously populated since medieval times, which is illustrated by overlapping material from different periods in the individual settlements, their ancient monuments and groups of buildings.

One key to understanding the society and spirit of the Foothills of the Tokaji Wine Region is the oppidum (market-town), a special type of settlement unique to Hungary. The upswing of rural commodity production, generally in the 14th century, strengthened larger villages in commercially important locations. In time, these communities developed their own institutions of local government and obtained certain privileges, such as the payment of tax in a lump sum instead of individual payments by every dweller.

From the mid-17th century on, the flourishing oppidums came under an all-out attack from the landowners. One of the two groups that mounted a successful resistance to this attack consisted of the large, Ottoman-ruled towns on the Plain that had absorbed the population from the abandoned villages and became the property not of the Spahi, but of the Treasury as territories of distinguished value. Their economic prowess relied on the extensive rearing of gray cattle and on brisk trade, which supplied them with enough cash to appease the gluttony of the Ottoman dignitaries by peaceful means.

The other large group of the oppidums that managed to negotiate survival comprised settlements specialising in wine. Especially successful among

them were the proud oppidums of Tokaji region, each with a firm sense of identity which developed an unusually dense network in this region. Sárospatak, Sátoraljaújhely and Tolcsva had won oppidum status before the 1300s; Tokaj, Tarcal, Olaszliszka, Szerencs, Tállya and Abaújszántó in the 15th century; Erdőbénye and Mád in the 16th, and Bodrogkeresztúr in the 17th century. Some of them were destroyed more than once, but they always rose from the ashes. The grape-growing, wine-making serfs, artisans of the oppidums, together with the nobility who moved into them in increasing numbers, were quite successful in defending the rights of these settlements. The oppidums saw their halcyon days in the 16th and 17th centuries, and left us memento of wonderful buildings and monuments.

A unique architectural value of the area is the rich variety and mixture of the architecture of the aristocracy, the great domains, the forming middle class and the peasantry architecture of the area.

The grapes are grown in the vineyard, but the wine is made in the cellar. This is simple enough, but cellars and wineries may vary greatly in appearance, depending on the type of wine made in them. This is especially true for a wine region like Tokaj, shaped by centuries of tradition and long-established local wine specialties. The cellar, today superseded by the winery, has no doubt become the characteristic type of building across the Foothills of the Tokaji Wine Region. Here it has evolved through the centuries in very different ways than in other parts of Hungary.

The construction of most cellars in the Foothills of the Tokaji Wine Region took place between the mid-1500s to the late 17th century, during the period of the region's ascendancy.

Beyond the fact that cellars are typical architectural elements in the settlements of the wine region, the princely Rákóczi Wine-Cellar at Sárospatak, the Ungvári Wine-Cellar at Sátoraljaújhely, the row of multilevel cellars at Hercegkút, the historical cellars of Oremus company and the Wine Museum of Tokaj Kereskedőház at Tolcsva deserve special attention.

2.4.2 Ecological significance

The National Physical Plan specifies the Tokaji Wine Region as part of the national level ecological system. Areas listed in the zone contain the habitats and ecological values and thus serve the defence of biodiversity through providing sustainable utilization and use.

Nature conservation areas and protection zones in the area of the Tokaji Wine Region bear peculiar ecological importance. Geographical, geological and climatic capabilities of the area, that favour vine growing greatly, is an

elementary condition for the production of the outstanding quality wine, known for centuries. The survival of this has never been endangered by developments or industry implantations that are dangerous to the ecological system.

A geological-archaeological celebrity is the *Vitis Tokaiensis* that is one of the finds that date back to the Miocene flora and was found here, in Erdőberénye. This ancient grape-leaf, which can be regarded as the ancestor of each and every grape-type, proves that the grape is a pre-historic endemic plant in Tokaj. The primary vine, the *Vitis sylvestris* is growing wild in Tokaj even nowadays.

2.4.3.- 2.4.4 Social-economical significance

Vine growing is not only based on outstanding natural and ecological capabilities, but its social conditions and economical consequences are also of high importance. It cannot be reckoned as a sole natural, social or economical issue.

The centuries old traditions of vine growing and wine production at Tokajhegyalja are still determinant factors in the life of the present society. Traditions, as being living store of learning, facilitate many among such inhabitants in the area to be able to contribute to the works in periods of higher labour intensity, like cutting or harvest, that otherwise, in other periods may pursue a profession that is not connected to grape or wine at all. Thus grape and wine has a population-keeping role in the area as well. Increasing the grape growing areas is not an objective, but the replacement of perished vineyards of first class climatic and topographical facilities is a prime economical and social interest of the wine region. It is very important to provide areas of extraordinary facilities with landscape-, and nature-friendly infrastructure.

Cultured consumption of quality wine products is part of the culinary and behavioural culture.

The Tokaji wine, which has a significant role in the identity of the people living in this landscape, beyond its social-economical importance in the region, also represents extraordinary national and international value. The village and wine tourism, based on this, in the otherwise economically depressed region, has an important, population keeping role as an alternative income-raising potential.

3. Connections of the management plan and legal issues

3.1 The organization of management: Management Forum

The core area with its 132,555 km² and the four individual sites are under the management of thirteen local governments. Effective management seemed practical to be based on the local governments concerned. Assigned representatives of the concerned – on the basis of the operative Tokajhegyalja Mayors Forum – raise a Management Forum, which specifies and adopts the necessary measures on regular sittings, harmonizes the action program and makes proposals on the utilization of resources. The Management Forum is complemented with constant guests. These include organizations of national level importance, representatives of owners of the individual sites and the self-regulating organization of all vine-growers of the core area and the buffer zone.

Settlement local governments

Tokaj
Bodrogkeresztúr
Bodrogkiszfalud
Herceggút
Mád
Mezőzombor
Rátka
Szegi
Tarcál
Tállya

Organizations of national scope of authority

Nature Conservation Office
Cultural Heritage Protection Office

Owners of the individual sites

Megyer Rt.
Tokaj Kereskedőház Rt.
Oremus Rt.

Self-regulating Organization of Vine-growers and Oenologists

Wine Community Council of Tokajhegyalja Wine Region

3.2 Documents of self-regulation

The planned Regulation of the Wine Community Council of Tokaji Wine Region

The operation of the regulation:

The administration area - Tokaji Wine Region

The regulation is obligatory for every member of the wine community.

The subject of the regulation: professional regulation of grape cultivation and viticulture in the area of the wine community, sanctioning offences against the regulation, and regulation of procedures.
(See Management Plan I, 2000)

Management plan of nature conservation areas:

The nature reserves that are wholly or partly located in the proposed region or the puffer zone (Tokaj-Bodrogszegi Tájvédelmi körzet, Tállyai Patócs-hegy and Bodrogszegi Várhegy) have a handling plan whose arrangement and content is suitable for the international conventions.
(See Management Plan II, 2000)

Local settlement plans – Regulations for value conservation

The Act No. CXV of 1999 obliges the local city council to renew the physical planning before the end of 2003 and to constitute regulations for the conservation of local architecture values. Local physical planning compulsorily matches the instructions of the regional plans. (See Management Plan 2., 2000)

3.3 Legal restrictions

According to the Hungarian legal system, the direction independence of the city councils can be controlled only by laws that serve public interest even in regional reference. Such public interests are protected by the following laws: (attached in the other volume of the management plan)

- Act No. LIII of 1996 on the protection of environment
 - Act No. CXXI of 1997 on grape cultivation and viticulture
 - 106/1997. (XII. 19.) FM decree on the enforcement of Act No. CXXI of 1997 on grape cultivation and viticulture
 - Act No. LXIV of 2001 on the protection of cultural heritage (enacted instead of the Act No. LIV of 1997 on the protection of monuments.)
- (See Management Plan 2., 2000)

The legal approval of the National Physical Planning that contains decisions protecting the interests of the region is in process.

National Physical Plan (See Management Plan 2., 2000)

The aim of the National Physical Plan is to determine the country's perspective spatial structure (the location of the national transport and public utility networks, the system of urbanized, agricultural and natural regions), to regulate

broadly the land-use and the protection of natural resources, and to ensure the technological and ecological frame conditions of developments.

The tasks of the National Physical Plan are:

- to make the spatial structure better-balanced
- to ensure a more consistent integration into the global and European connection-system
- to create high quality conditions of the land-use in the region
- to create the regional conditions of a development perspective that is favourable for settlements and settlement groups.

The area is classified into the following zones serving protection and handling by the National Physical Plan:

- the zone of the national ecological network,
- the zone of sensitive natural areas,
- the zone that is of high importance in the viewpoint of the cultural heritage,
- the zone of the protected areas of high priority in air-cleanness viewpoint.

3.4 Sources of possible conflicts

Conflicts resulting from mining activity

Conflicts resulting from mining activity can be divided into two major groups. The first is the group of after-effects of previous mining activities, these are normally landscape wounds, such as mining courts and lakes, hump-yards, waste deposits, abandoned without recultivation.

Part of these mines belongs to the areas of valuable landscape and natural facilities, which are often protected. Possible excavations are basically related to non-metallic minerals.

Conflicts resulting from silviculture

Inefficient accordance of the interests of silviculture and nature conservation may result in landscape use conflicts. After 1990 the professionally unskilled new owners often prefer to plant in their areas landscape alien species that are cheaper to operate. In certain areas bark supplants the more valuable sessile oak.

Conflicts of social origins

In certain borderlands of settlements concerned by tourism and recreation, the late vine-hills might be degraded into weekend house areas.

3.5. Correction procedures

The operability of the management plan rests upon its consensual acceptance, thus the Management Forum, which congregates the interested parties, is authentic to act if the management rules are violated as well as it should try to correct such violation or abuse with the involvement of the parties concerned, and to arrange the conflict.

4. Objectives, directives

4.1 Register of natural and cultural values (see in annex attached to the management plan 3.)

- GIS based spatial database
- Cadastre of Winery and viticulture
- Nature conservation areas
- Archeological sites
- List of monuments
- List of local monuments and sites

4.2 List of issues endangering the property

As a result of the geological variety of the area, it is exceptionally rich in non-metallic mineral resorts, such as zeolite, kaoline, bentonite etc. Open cut mining can entail landscape, air pollution and noise issues.

4.3 Conservation and protection principles

In the national, regional and local plans specifying the prospects and the future of the area, environmental, natural, landscape, grape growing and cultural heritage protection are high-priority concerns. (See in: Management Plan 2000, Vol. I.) Protection principles are in accord with the concerning international

conventions. Decisions of the plans are based on the principles of integrated protection and sustainable development.

With the deconstruction of the industry in the county, industrial air pollution is decreasing.

There is no flood danger in the core area. There are areas protected by levees in the areas along the Bodrog and Tisza rivers in the buffer zone. Due to ecological changes in the collecting areas extending over the state borders, purposeful fortification of the protection system is in progress.

4.3.1 Catastrophe protection

Catastrophe protection plans are prepared at the County Catastrophe Protection Directorate on the regional level, and at city catastrophe protection sub-offices and the local governments of smaller settlements. The leader of the task of county level catastrophe protection is the president of the General Assembly of Borsod-Abaúj-Zemplén County. Leaders of the city sub-offices are the local mayors, and in the villages mayors are the assigned responsables on the settlement level.

4.3.2 Fire-protection

The county, the cities and the villages all dispose of their own fire protection plans. The fire protection plan of the county is kept at the Fire Station of Borsod-Abaúj-Zemplén County, those of the cities are at the city fire stations, and the plans of the villagess are at the local volunteer fire brigades. Regular excercises are kept by the competent fire captaincies.

4.3.3 Resolution of mining impacts

Open air mining is strictly regulated, thus mining seats the life, culture and landscape values of the region.

The basis of this activity is set down in the Act No. XLVIII of 1993 on Mining. The act regulates excavation in accord with life, health, safety, environment protection, private property protection and the management of mineral resources. Mines have their own mining sites, this is the basis of the activity.

Mining activities are bound to the licence of the Inspection of Mines, in accord with the Technical Industrial Plan. Further proviso is the elaboration of a Landscape Plan.

In the confirmation clause of the Technical Industrial Plans, the regulations of the authoritative Environment Protection Inspectorate, National Park Directorate and Water Management Directorate are laid down.

The blast, splinter and seismic effects of the explosions are to be kept on the possible minimal level through due planning and actuation, with the involvement of experts.

The noise and dust burden resulting from boring, exploded stone collecting, its transport, breaking and selecting, must be reduced by technical solutions, and specified environmental limits are compulsory. Instruments to be applied in the field of reducing environmental side effects are modern appliances, such as boring machines equipped with automatic dust exhauster, low noise level excavators, dump trucks, front-end loaders, coating of the installed appliances, the application of wet dust precipitation, dust-absorption of transport corridors, and their covering with asphalt, and the recultivation of abandoned quarries.

4.4 Objectives reinforcing the present state of protection and conservation of the property

Better utilization of the valuable grape yards.

Development of nature friendly tourism.

Construction of the digital value registering systems.

Landscape recultivation.

4.5 Objectives – prospects

It is reasonable to handle the Tokaji Wine Region as a nationally outstanding value.

It is to be achieved that the protection, development and management of the Tokaji Wine Region cultural landscape be reckoned with adequate emphasis, in accord with its value, as set both in the national and in the regional plans.

Protection of the landscape, natural and cultural heritage values, achievement of the highest possible level of sustainable utilization of the facilities, and the vitalization and optimization of landscape and environment-friendly economical activity are exposed aims.

Another exposed task is the due utilization of first class grape producing areas, the provision of quality production and due infrastructure for areas of extraordinary facilities and their conservation.

Quality protection ought to be supported through differentiated regulation.

Development of the settlements must be harmonized with the conservation of landscape and natural values.

The subsistent proportionate historical landscape structure, the settlement network and settlement structure must be protected. Specification of larger development areas must be withheld and increment of intra areas must be restricted. In those areas of the wine region that are specially sensitive in landscape concerns, building activity must be restricted, but especially greenfield investment and land waste. Technical and aesthetic condition of the settlement centres must be improved.

The potentials of tourism must be increased through the improvement of cultural, health and other personal services, the harmonization of the interests of landscape- and nature protection with tourism.

From the point of view of the future of the area it is of strategic importance to develop tourism, especially wine-, eco-, and village-tourism, bicycle and horse riding tourism.

Causes of transmigration must be abolished, especial as far as the intellectuals are concerned. Conditions of healthy mode of life and health care must be improved.

Special attention must be paid to the tackle of depopulation of the small villages, for example, through the improvement of the road system, the support of village tourism, job creation in agriculture in accord with the landscape facilities, organization of investments, and project preparative and marketing activity.

Territorial inequalities must be alleviated through the introduction of a balanced development model.

An attractive economical environment must be established. Replantation of perished first class grape-growing areas, development of village accommodations, survival of traditional crafts and construction of the bicycle route system must be supported.

A support system must be elaborated for an environment-friendly, local resolution of energy supply.

The high rate of agricultural self-supplying must be corrected through the creation of alternative income raising facilities.

Recultivation of derelict mines, landscape wounds must be accelerated.

Emission of air polluting materials must be decreased.

4.5.1 Short term objectives, priorities – actualization strategies

The Management Forum must have the geographical information system compilation concerning basic data of the area accomplished. It has to organize regular data updating and monitoring of the core area on this basis.

The Management Forum must participate in the conforming work through the elaboration of regional and local settlement plans, and must opine so that it would carry considerations that are for the conservation of the values of the wine region.

The Management Forum must conform the PR and marketing activities of core area settlements, their investment organizing work and project preparative tasks. It is reasonable to base this balanced activity on the role of the central core area of Tokaj town.

Digital administrative systems must be created for the first and second class grape growing areas. The marketing system of utilization must be elaborated in the framework of the cooperation already launched with the Szent István University.

The unique landscape values must be surveyed and cadastred.

Landscape wounds of derelict mining areas must also be surveyed. Schedules must be prepared for the recultivation works.

Concerted settlement historical and settlement architectural reseaches and publication of the results must be organized.

The most basic aesthetical and technical problems of the settlement centres must be enlisted and schedules must be prepared for their correction.

Harmonization of development with value protection must be confirmed in the value protection decisions and in the settlement plans that must be renewed until 2003. Specification of larger development areas must be withheld and increment of intra areas must be restricted. In those areas of the wine region that are specially sensitive in landscape concerns, building activity must be restricted, but especially greenfield investment and land waste.

It is important to support and encourage the preparation of tenders aiming at the elaboration of wine-, eco-, and village-tourism, bicycle and horse riding paths.

Budgetary plan must be elaborated for the actualization of mid-term objectives.

4.5.2 Mid-term objectives

The Management Forum, in cooperation with the national and country level tourism organizations, works out a mid-term tourism plan, the objective of which is to turn the present transitive capabilities of the area into a target area for longer staying.

A support system must be initiated for the replantation of perished first class grape growing areas, and to support the preferential economical environment of grape and vine production.

It is a mid-term task to elaborate the tourism infrastructure in villages for wine-, eco-, and cultural tourism. The establishment of horse riding and bicycle paths must be commenced. The “fresh air” tracing is proposed, that is, routes that escort flood-gates, forest paths and national touring tracks.

In the road construction programme, priority must be provided for the by-pass road that by-passes the settlement centres of Tokaj, Tarcál, Mád and Tállya.

Provision of the continuity of originally short-term objectives that extend into mid-term periods.

5. Tourism data, objectives, schedules

5.1 Main elements of the regional tourism offer:

The territorial concept of tourism is based on wine-, nature- and cultural tourism.

5.2 Tourism infrastructure

5.2.1 Transport facilities

- Approachability

The Tokaji Wine Region is basically in favourable situation, because lays close to the rail and public road routes connecting Budapest through the county centre to east Slovakia, that is, having good transport connections, whereas it is free of the damages of direct transit.

- Parking facilities

There is no parking problem, because the traffic is not attracted by a single object in the central core area, but several tourist attractions that are situated in several parts of the town, both in the intra area and in the outer areas. The centre of Tokaj, which is the most important tourist attraction, is a pedestrian zone without transit traffic. Parking places are established outside the town centre.

5.2.2 Information

Tourist information centre: Turinform, Tokaj, 3910 Serház út 10.

Phone: 00-36-47-352259, Fax: 00-36-47-352259,

E-mail: tokaj@turinform.hu

5.2.3 Numeric data of catering services

	Number of restaurants 2000	Non hotel accomodations 2000	Number of guests in all accomodations 2000	Number of guests from abroad in all accomodations 2000	Number of guest-nights in all accomodations 2000	Number of foreigner guest- nights in all accomodations 2000
MEZŐZOMBOR	8	228	3391	419	6935	847
MÁD	14	-	-	-	-	-
BODROGKISFALUD	5	-	-	-	-	-
SZEGI	1					
TÁLLYA	17	19	286	-	580	-
RÁTKA	3	24	118	15	548	31
TOKAJ	56	158	5487	2046	8904	3244
TARCAL	18	-	-	-	-	-
BODROGKERESZTÚR	6	20	515	4	1325	6
Total of core area	118	449	9797	2484	18292	4128
Total of Hungary	49945	194606	5940805	2992401	18 327 047	10513825

5.3 Major tourism programmes and number of visitors

Important events in Tokaji Wine Region				
<i>Event</i>	<i>Place</i>	<i>Time</i>	<i>Visitors</i>	<i>Features</i>
Grape harvest days	Settlements in Tokaji Wine Region: Mád, Tállya, Bodrogkeresztúr, in the centre of Erdőberénye, the main programme is in the main street of Tokaj	End of September, beginning of October 1-2 days	30 000 people	Traditional grape harvest parade, local wine contest, wine tents, open market, tools of viticulture, traditional song and folk dance groups
Cultural Days in Zemplén	Settlements of Zemplén, Sárospatak	August one week	10 000 people	Concerts of classical music, cultural events, ball and dinner
Farmers' Days in Hegyalja	Szerencs city centre	The weekend before Whitsuntide 3 days	25 000 people	Wine contest of Tokaji Wine Region, vocational conference, the presentation of the values of the area, professional market of 150 exhibitors
Tarcal Fair	Sports ground in Tarcal, Kóposz hegy of Tokaj	End of July 2 days	5-6000 people	Demonstration plays of the Árpád Age: horsemen and bowmen, recalling of historical wine-routes
Children's and Gypsy Dance Festival	The Cultural Centre of Sátoraljaújhely	August 2 days	5-6000 people	Hungarian and foreign groups
Festival of German minority	Rátka	1 st Saturday of september	1500-2000 people	Choirs, orchestres, dance groups from five countries

5.4 Possible damages caused by visitors

The abrupt tourism traffic of the few days long activities generates increased traffic and parking burdens for the environment. Environment pollutive effect of the waste and litter left behind by the audience must be taken into consideration. However, these problems are controllable, and they do not mean long-term damages.

5.5 Description of tourism policy

Tourism has a significant role in the future of the region. The principal aim of tourism policy is to maintain, develop and publicate values of the region.

Productivity of tourism can be further improved along with observing the principle of sustainability through the improvement of cultural, health and other personal services.

Tourism policy of the region is specified by the following structure:

- *Wine tourism*

Tourism in relation with the fame of the Tokaji wine, with grape growing and wine production, with the cultural facilities of the landscape and festivities, programmes.

- *Cultural tourism*

tourism serving the presentation of the values of historical and ancient monuments in the area. Meetings in the literary, musical and visual arts world are traditional in the area.

- *Village tourism*

Tourism presenting the nature harmonious silviculture, village economizing and crafts.

- *Ecotourism*

Recognition of wildlife, topographical forms. Wayfaring, bicycle and horse tourism.

5.6 Special objectives concerning sustainability of tourism

The No. 3713 through road leading on the south-western border of the core area must be moved further from the centre. This will facilitate the elaboration of additional attractive pedestrian roads in the settlement centres of the core area, and the environmental impact of the proposed area decreases. For this reason, the earliest possible construction of the planned by-pass road for the Tokaj-Tarcal-Mád-Tállya route must be encouraged on the level of road network development concept.

5.7 Short- and mid-term tourism objectives

Among the development conceptions of tourism, the role of settlements in the buffer zone must also be recognized, thus expressing the natural, landscape and cultural unity and coherence of this historic wine region.

Involving settlements of the buffer zone, based on a balanced tourism conception, the presently transitional capabilities of the area must be transformed into a target area that is capable of longer staying.

In the core area, the tourism infrastructure must be allocated with Tokaj as the centre, but more balanced, taking appropriately into consideration the catering capacities of the other settlements as well.

The abrupt nature of tourism must be alleviated through the provision of alternative tourism offerings.

On the existing basis, elaboration of the tourism infrastructure in villages for wine-, eco-, and cultural tourism must be developed. The establishment of horse riding and bicycle paths must be commenced.

6. Actualization of the management plan

The coordinative body of the adoption and actualization of the management plan is the Management Forum, which is based on the Tokajhegyalja Mayors Forum. The Management Forum is complemented with constant guests. These include organizations of national level importance, representatives of owners of the individual sites and the self-regulating organization of all vine-growers of the core area and the buffer zone.

6.1 Schedule of regular sittings of the Management Forum

The Management Forum specifies and adopts the necessary measures on regular sittings, harmonizes the action program and makes proposals on the utilization of resources on its annual regular sittings, or on additional sittings, if necessary. It provides continuous cooperation and coordination among the various bodies and participants. The Management Forum supports and organizes the joint participation of the concerned settlements in tenders.

6.2 Secretary of the Management Forum

The Management Forum assigns a secretary. The task of the secretary is to hold up the intercourse between the sittings, to monitor tender facilities, informative activity, organization of the sittings, continuous monitoring of the actualization of world heritage interests. The secretary must report to members of the Management Forum on extraordinary events.

6.3 Budget

Members of the Management Forum create a joint budgetary fund. The aim of the budgetary fund is to support objectives and initiatives serving the defension and actualization of world heritage interests, first of all, the monitoring of the area, the provision of regular meetings, financing of researches, surveys and planning, support of tenders.

6.4 Communication and information service

the keystone of the efficient management of the world heritage property is the social support. It is important to publish that the world heritage is extremely sensitive, unreproducible heritage, whose maintenance deserves accordingly sensitive, cautious consideration and harmonization of interests. To this end, the widespread interpretation of the management plan, forums for the local inhabitants and owners, public reports are elementary. Several methods of publication must be elaborated so that the opinions of the various interest groups be recognized. It is important to make use of the publicity provided by the local press and other media just as that of the internet. It is reasonable for the Management Forum to create an own website.

7. Regular review of the Management Plan – base data of the initial state

7.1 Revision

The management plan must be put through basic review in every six years. The review is organized and directed by the Management Forum. The Management Plan can be complemented or must be modified if necessary, on the basis of occurring development and physical planning issues and new results of researches.

7.2 Database of the initial state

As far as landscape architecture and grape production is concerned, the Tokaji Wine Region established a traditional relationship with the Szent István University.

The Research and Monument Office of VÁTI Public Utility Society prepared the geographical information system (GIS) of value cadastre and database for the area proposed for world heritage protection. Based on regular national statistical data collection and data of organizations with national scope of activity, the database contains those indicators in spatial informatics context, which are the most important measurable and comparable properties of the area, and the regular monitoring of which is an accurate means for tracking the quality changes of the area. This database forms the basis of future monitoring of the area. The organization and data update for the monitoring activity is the task of the Management Forum. The database connects to the Regional Development and Spatial Planning Information System, run in VÁTI, and might be accessible through the internet as well, if the necessary conditions are provided.

Authentic copies of the approved Management Plan will be placed and accessible at the Secretariat of the Hungarian National Committee of the World Heritage, further copies will be placed at the local governments concerned.

8. Annex 1e – Supplement

Annex of the Management Plan 3. contains the following value registers:

- Content of the GIS-based spatial database
- Cadastre and winery and viticulture of Tokaji Wine Region
- Nature conservation areas
- Archaeological sites
- List of monuments
- List of local monuments and sites